

884  **DECRYPTOR**
ultra

Operating manual





Terms of the Guarantee

KEYLINE S.p.A guarantees the good working condition of the machine for a period of 12 months from the date of purchase and undertakes to replace or repair the machine, or its single parts, if any operating faults are discovered at origin.

The guarantee does not cover any faults or damage caused by the user's negligence when using, or that is caused by repairs, replacement of single parts or maintenance that is carried out by individuals not authorised by the seller, or by any other circumstance that is independent of the seller.

The expense incurred in repairing or replacing the machine is the responsibility of the seller except for the expense of transport to and from the workshop. Those parts that are subject to wear, such as milling cutters, clamps, brushes etc.

are excluded from the guarantee. In order to use this guarantee the client undertakes, under penalty of cancellation, to communicate any operating defects covered by the guarantee to the seller within 30 days of their discovery.

Condizioni di Garanzia

KEYLINE S.p.A garantisce al compratore il buon funzionamento della macchina per un periodo di 12 mesi dalla data di acquisto e si impegna a sostituire o riparare la macchina, o i singoli componenti, qualora vengano riscontrati difetti di funzionamento all'origine.

La garanzia non copre i difetti o i danni causati dall'utente a seguito di negligenza nell'uso, ovvero causati da riparazioni, sostituzione di singoli componenti, manutenzioni effettuate da soggetti non autorizzati dal venditore, ovvero da qualsivoglia circostanza indipendente dal fatto del venditore.

Le spese di riparazione o sostituzione della macchina sono a carico del venditore escluse quelle di trasporto da e per la sua officina. Sono esenti da garanzia le parti di usura, quali frese, morsetti, spazzole etc. etc. Il cliente, per avvalersi della presente garanzia, si impegna a pena di decadenza a denunciare al venditore ogni vizio di funzionamento coperto dalla stessa entro 30 giorni dall'evidenza.



Via Camillo Bianchi, 2 - 31015 Conegliano (TV) - ITALY
Tel.: +39.0438.202511 - Fax: +39.0438.202520
Web: www.keyline.it
E-mail: info@bianchi1770.it
Technical Support: decryptor@bianchi1770.it

LIST OF CONTENTS

Decryptor Ultegra 884 - Brevetto depositato



1	General Information	3
1.0.1	Scope and contents of the manual	3
1.0.2	How to store the manual	3
1.0.3	Graphic symbols	3
1.1.0	Manufacturer's identification data	4
1.2.0	Working conditions	5
1.2.1	Intended use	5
1.2.2	Improper Use	5
1.2.3	Limitations of use	5
1.3.0	Terms and Conditions of Technical Assistance	6
1.3.1	Technical service and maintenance	6
1.3.2	Manufacturer's address	6
2	Safety instructions	7
2.1.0	Safety legislation	7
2.1.1	General safety requirements	7
2.2.0	Residual risks	8
3	Descrizione Ultegra 884 Decryptor	9
3.0.1	Components of the cloning tool	9
3.1.0	Accessories supplied with the cloning tool	10
3.2.0	Electric circuit	10
3.3.0	Technical features	11
4	Packing, transport and installation	12
4.1.0	Packing	12
4.2.0	Transport	12
4.2.1	Unloading and handling	12
4.2.2	Item ckecklist and detection of damage	13
4.3.0	Placing the cloning tool	13
4.3.1	Temporary storage	13
5	Installation	14
5.1.0	General Instructions	14
5.1.1	Work station	14
5.2.0	Environmental conditions	14
5.2.1	Temperature and humidity	14
5.2.2	Working environment	14
5.2.3	Lighting	14
5.2.4	Vibrations	15
5.3.0	Connections	15
5.3.1	Grounding	15
6	Use	16
6.1.0	Instructions for the operator	16
6.1.1	General instructions for use	16
6.1.2	Preliminary check-list and start-up	16
6.2.0	Settings	16
6.2.1	Getting started	16
6.3.0	How to use the cloning tool	17

6.3.1	Display	17
6.3.2	Starting the cloning tool	17
6.3.3	Software Version	17
6.3.4	Transponder reading (on the original key / remote control)	18
6.4.0	Cloning the fixed code transponder	21
6.5.0	Cloning of keys with Philips PH (33) transponder (using the KeyLine TK5/TK100 electronic head)	22
6.6.0	Cloning of keys with TEXAS FISSO TX00 transponder (using the KeyLine TK24/TK100 electronic head)	24
6.7.0	Cloning of keys with Texas* Crypto 1, 2 & 3 transponder (using the KeyLine TK40/TK100 electronic head)	26
6.8.0	Cloning of keys with PHILIPS CRYPTO I transponder (using the KeyLine TK50/TK100 electronic head)	29
6.9.0	Cloning of transponder keys with PHILIPS® Crypto PH20 transponder (using TK60 / TK100)	31
6.10.0	Cloning of remote controls with PHILIPS® Crypto PH20 transponder (using RK60)	35
6.11.0	Cloning of key/remote controls with PHILIPS® Crypto PH20 transponder (using RK60 - Fiat Panda)	40
6.12.0	New functions for version 02.030 - BI884	45
6.12.1	Codes generation	45
6.12.2	Holden Commodore	45
6.12.3	Holden Commodore OLD	45
6.12.4	Holden Commodore NEW	46
6.12.5	MEGAMOS MG00	47
6.12.6	Philips PH00	47
6.12.7	Temic TM10	48
6.12.8	Temic TM20	48
6.13.0	Procedure for the recovery of the original keys PEUGEOT PH1D	49
6.14.0	Cancellation, in order to use TK60 / TK100 again	50
6.15.0	Cancellation, in order to use RK60 again	51
6.16.0	Language setting	52
6.17.0	Error messages	53
6.17.1	Error messages during reading	53
6.17.2	Error messages during writing	53
6.18.0	Transponder identification	53
6.19.0	Updating the software	55
7	Maintenance	56
7.1.0	General information	56
7.1.1	Skills of maintenance personnel	56
8	Dismantling and disposal	57
8.0.1	Waste disposal	57
8.0.2	Disposal of the packing material	57
8.1.0	The WEEE directive	57





The user's and maintenance manual of the cloning tool "Ultegra 884 Decryptor", for the duplication and identification of transponder car keys, (henceforth "cloning tool") contains all operation instructions on how to use the cloning tool at best while guaranteeing the safety of operators.

1.0.1 SCOPE AND CONTENTS OF THE MANUAL

This manual provides basic information on the installation, operation and maintenance of the cloning tool.

It is addressed to machine operators and it enables them to use the cloning tool effectively, even if they do not have any previous specific knowledge. This manual describes the characteristics of the cloning tool at the time it is originally manufactured; therefore it may not capture later technological improvements introduced by KEYLINE S.p.A. as part of its constant endeavour to enhance the performance, ergonomics, safety and functionality of its products.

KEYLINE S.p.A., reserves the right not to update the manuals of previous versions of the machine.

Users must follow the instructions contained in this manual scrupulously, especially those concerning safety norms and ordinary maintenance.

1.0.2 HOW TO STORE THE MANUAL

The manual must always accompany the cloning tool that it refers to. The manual must be stored in a safe place, away from dust and moisture and it must be accessible to all users who shall consult it any time they are in doubt on how to operate the cloning tool.

KEYLINE S.p.A. reserves the right to modify its production and related manuals without necessarily updating previous versions of the reference materials.

The customer shall store any updated copies of the manual -or parts of it - delivered by the manufacturer as an attachment to this manual.

For any further information regarding this manual or the use and maintenance of the machines please contact KEYLINE S.p.A.

1.0.3 GRAPHIC SYMBOLS



- Indicates operations that can be either dangerous for people and/or disrupt the correct functioning of the machine.



- Indicates prohibited operations.

1.1.0 MANUFACTURER'S IDENTIFICATION DATA

KEYLINE S.p.A.
 Via Camillo Bianchi, 2
 31015 Conegliano (TV) - ITALY
 Tel.: +39.0438.202511
 Fax: +39.0438.202520
 Web: www.keyline.it
 E-mail: info@bianchi1770.it
 Technical Support: decryptor@bianchi1770.it

Key duplicating machine "Ultegra 884 Decryptor"
 voltage: *
 absorbed power: *
 absorbed current: *
 * See "Technical features" page 11.



		Via Camillo Bianchi, 2 31015 Conegliano (TV) -IT Tel +39.0438.202511 Fax +39.0438.202520 www.keyline.it info@bianchi1770.it decryptor@bianchi1770.it	
		BIANCHI1770SPA Company by	
Tipo Type	<input type="text"/>		
Matricola Serial No.	<input type="text"/>		
VOLT	Hz	Kw	RPM
<input type="text"/>	<input type="text"/>	<input type="text"/>	<input type="text"/>



Figure 1: Location of the machine data plate



1.2.0 WORKING CONDITIONS

1.2.1 INTENDED USE

The cloning tool described in this manual has been designed to identify, read and duplicate car keys with fixed code transponders and Crypto transponder codes Texas* and Philips* PH20 in "Stand Alone" mode, and identify all types of crypto transponder codes.

Moreover, the Decryptor Ultegra 884 can identify and clone Philips* Crypto PH20 remote controls for vehicles. With regard to this product, the manufacturer reserves the right to issue dedicated information and instructions after 15th October 2010, when the RK60 type KeyLine remote control will be released.

1.2.2 IMPROPER USE

The improper use of the cloning tool includes using the cloning tool to obtain different production than the one described in this manual. Should this occur the manufacturer shall take no responsibility for damage to materials or persons and shall consider all warranties on the cloning tool void.

1.2.3 LIMITATIONS OF USE

The Ultegra 884 Decryptor can be used exclusively to clone transponder car keys or electronic heads produced by KEYLINE.

Decryptor Ultegra 884 - Patent pending

KEYLINE[®]
PASSION FOR KEY INNOVATION



*TEXAS is a broad meaning of TEXAS Instruments Incorporated registered as a trademark
*PHILIPS is a broad meaning of PHILIPS Instruments Incorporated registered as a trademark

1.3.0 TERMS AND CONDITIONS OF TECHNICAL ASSISTANCE

1.3.1 TECHNICAL SERVICE AND MAINTENANCE

The manufacturer shall be accountable for servicing the product during the warranty period and for causes related to the use of the cloning tool.

Ordinary maintenance operations shall be performed by the personnel who use the cloning tool.

Any other operation (special maintenance, repairs, replacements etc..) shall be carried out by qualified personnel or contractors. KEYLINE S.p.A. is available for this assistance and guidance.

KEYLINE S.p.A. is at your disposal for:

- clarification and advice;
- delivery of spare parts;
- direct assistance through in-house technical counsel;
- direct assistance through authorised personnel.

Any servicing by the operator itself during the warranty period must be previously authorised by KEYLINE S.p.A.

The warranty will become void in case of:

- unauthorised operations and use;
- use of non-original spare-parts.

1.3.2 MANUFACTURER'S ADDRESS

For any further information or technical service related to extraordinary maintenance or repairs, please contact:

KEYLINE S.p.A.
Via Camillo Bianchi, 2
31015 Conegliano (TV) - ITALY
Tel.: +39.0438.202511
Fax: +39.0438.202520
Web: www.keyline.it
E-mail: support@bianchi1770.it

To facilitate communication please state:

- the name of the final customer and of the KEYLINE distributor;
- the identification data printed on the machine data plate (fig. 1).



SAFETY INSTRUCTIONS

Decryptor Ultegra 884 - Brevetto depositato



2.1.0 SAFETY LEGISLATION

The Ultegra 884 Decryptor and the relevant accident prevention equipment comply with the health and safety requirements of the Low Voltage Directive 2006/95/EEC.

This manual lists all safety instructions that the operator must follow during the installation and functioning of the cloning tool.

Failing to respect the instructions may compromise the safety conditions envisioned during design and testing phases.

When employed for their intended use all machines marked CE comply with EU 'Low Voltage' directive 2006/95/EEC and later amendments (in accordance with norm EN 60950).

Warning:



Important!

Users must be informed about the instructions contained in the following pages.

Users must carefully follow the instructions contained in this manual.

2.1.1 GENERAL SAFETY REQUIREMENTS

Warning:



Important!

Make sure that the grounding system is well connected.

Do not pour water or other liquids onto electrical cables and connections.

2.2.0 RESIDUAL RISKS

The cloning tool has been designed with the almost care to make it safe throughout manufacturing, quality control, transport, adjustment and maintenance operations. Nevertheless, not all risks for either operators or the environment could be eliminated, be it for technological reasons (material reliability) or management-related issues (overcomplicated operations).

Therefore, when operating the cloning tool, the following residual risks - as well as those connected with its use - must be taken into due consideration:



- **Risks related to the place of installation**

The place where the cloning tool is installed might present hazards that could disrupt its correct functioning (see paragraph 5.2.0. on page 14).



- **Electrical hazard**

Since the cloning tool is equipped with electrical devices, in case of faults there might be a risk of electrocution. The power line must be fitted with the appropriate control and protection devices (circuit breaker, thermal overload switch and differential switch).

DESCRIZIONE ULTEGRA 884 DECRYPTOR

3.0.1 COMPONENTS OF THE CLONING TOOL



Figure 2: Components of the cloning tool

COMPONENTS OF THE CLONING TOOL			
1	ON/OFF Switch	7	Power supply connection
2	Read/write key insertion slot	8	Serial port (RS232)
3	Liquid Cristal Display	9	USB interface
4	WRITE button	10	Anti-shock body
5	READ button	11	External 9-15 Volt power supply
6	Number keyboard	12	9-15 volt power cable

3.1.0 ACCESSORIES SUPPLIED WITH THE CLONING TOOL

The cloning tool comes with a complete kit of standard accessories:

- External 9-15 Volt power supply unit (11)
- 9-15 volt power cable (12)
- User's manual

3.2.0 ELECTRIC CIRCUIT

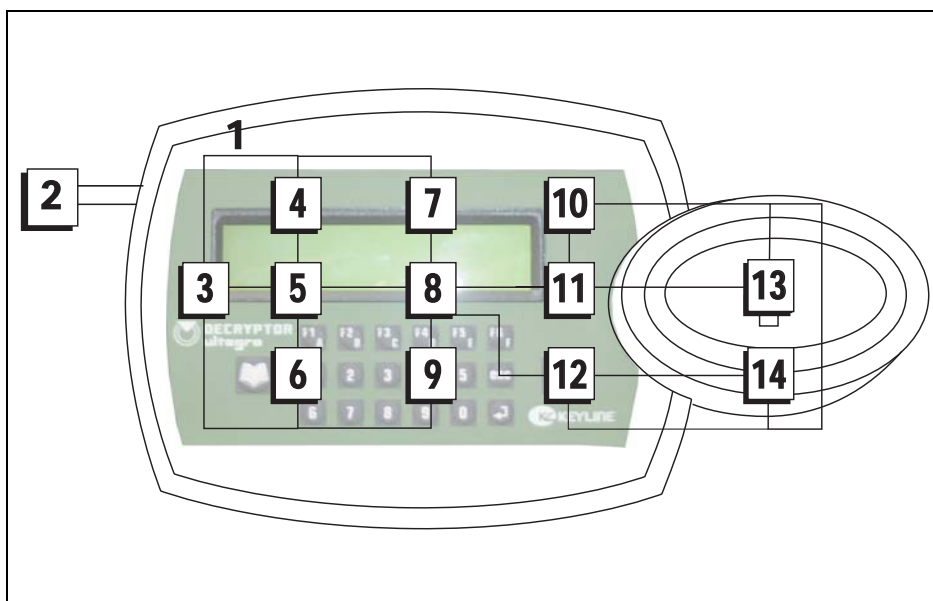

Figure 3: Electric circuit diagram

ELECTRIC CIRCUIT DIAGRAM PARTS			
1	Electronic board	8	Control unit
2	External 9-15 V DC power supply	9	Keyboard
3	Internal power supply 2	10	Internal power supply 1
4	RS232 serial interface	11	Radio module for modulation transponder
5	Communication module	12	Radio module for Texas transponder
6	USB interface	13	Antenna for transponder
7	Display	14	Antenna for Texas transponder

3.3.0 TECHNICAL FEATURES

CLONING TOOL DIMENSIONS	
Width	220 mm (Inch. 8,6)
Height	70 mm (Inch. 2,7)
Depth (Length)	130 mm (Inch. 5)
Weight	1 Kg (2.2 Lbs)
POWER SUPPLY	
External power supply	100/250 V - 50/60 Hz
Absorption	1 Ampere
Type of power supply unit	Universal
TECHNOLOGY FEATURES	
Field frequency of key insertion slot	125 KHz
Memory	4 GB
Interface	Serial port RS232 and USB
Working temperature	0°C ÷ + 40°C + 32 °F ÷ + 105 °F

Table 1: Technical features



PACKING, TRANSPORT AND INSTALLATION

4.1.0 PACKING

Prior to transport, the cloning tool and its component parts are packed in a cardboard box and fixed in it with shaped cardboard in order to ensure a safe and damage-free handling of the goods.

The dimensions of the carton are shown below.

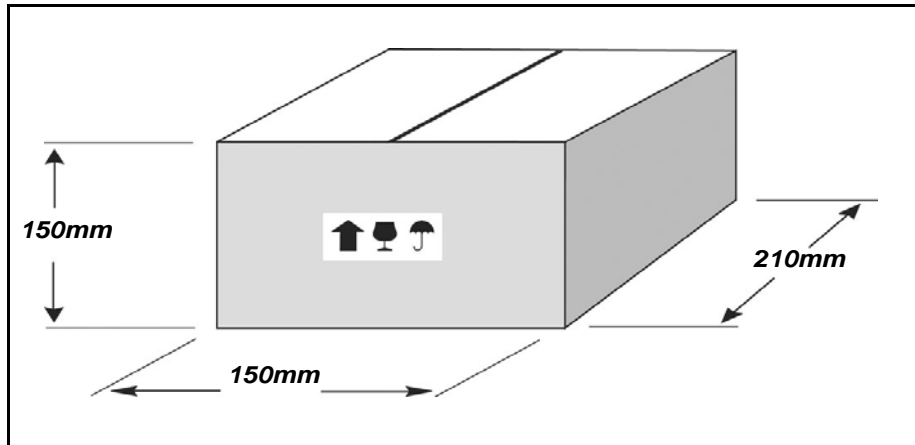

Figure 4: Package size

Warning:



IMPORTANT!

We recommend you to keep the packaging during the warranty period.

4.2.0 TRANSPORT

As a rule, the cloning tool is dispatched with component parts already assembled.

The markings on the packing materials indicate how to handle the machine during transport.

4.2.1 UNLOADING AND HANDLING

The machine can be unloaded manually; no hoisting equipment is required.

Warning:



Avoid dropping the machine, even a small damage could impair its correct functioning.



4.2.2 ITEM CKECKLIST AND DETECTION OF DAMAGE

Upon delivery, check that all items listed in the consignment note or in the packing list are in good condition. If any items are missing, the packing has been tampered with or the goods are damaged write a statement in the delivery note, sign it and have the carrier sign it too. Notify KEYLINE S.p.A. immediately and wait for the relevant instructions.

Please note that if you fail to notify us of the damage immediately you will lose your rights to damage compensation.

Do not remove protective covers before the installation - unless they are damaged.

Packages that were opened to examine the contents must be handled with care to avoid damaging the goods; re-pack the parts and store them in a safe place until the installation.

For more detailed information on how to handle these parts refer to the chapter "Temporary storage" page 13.

4.3.0 PLACING THE CLONING TOOL

Free the device form the protective padding, then place the **Ultegra 884 Decryptor** on the work bench.

4.3.1 TEMPORARY STORAGE

If the installation of the cloning tool does not occur immediately, store the machine in a dry and properly ventilated place.

Warning:



If the period of inactivity is longer than 6 months, inspect the cloning tool carefully.

To avoid that inaccurate operations or re-assembling may damage the equipment at the time of start-up, the utmost care must be used in performing such inspection, that shall be carried out by qualified and skilled personnel.

Warning:

IMPORTANT! Make sure that:



the iron structures are not dripping;

The transit of equipment, goods or people near the cloning tool does not damage it.

5.1.0 GENERAL INSTRUCTIONS

5.1.1 WORK STATION

The cloning tool will be operated only by one operator who will stand in front of the cloning tool and make sure of the following:

- Keep the work station tidy and free from objects that may hamper regular cloning tool operations;
- Make sure that environmental conditions allow to work safely (appropriate lighting, temperature and humidity);
- Keep unauthorised personnel out of the area.

5.2.0 ENVIRONMENTAL CONDITIONS

5.2.1 TEMPERATURE AND HUMIDITY

The cloning tool should be used in rooms with a temperature range of 0 - 40 °C (32 °F - 105 °F) and a relative humidity lower than 50 - 60%.

5.2.2 WORKING ENVIRONMENT

The cloning tool must be used in a place protected from bad weather (rain, hail, snow etc.).

Warning:



If the cloning tool is used in places exposed to corrosion, maintenance shall be scheduled in such a way as to prevent extreme wear of the components.



Do not use the cloning tool in explosive or partially explosive atmosphere or in the presence of inflammable liquids or gases.

5.2.3 LIGHTING

In the place of installation lighting must be appropriate, in order to allow the correct use and maintenance of the cloning tool. The user shall be responsible for complying with the legislation in force regarding lighting.

Decryptor Ultegra 884 - Patent pending

KEYLINE
PASSION FOR KEY INNOVATION



5.2.4 VIBRATIONS

The use of Ultegra 884 Decryptor does not cause any vibrations.

5.3.0 CONNECTIONS

5.3.1 GROUNDING

Ultegra 884 Decryptor have been designed in compliance with the safety legislation in force and feature appropriate safety devices to prevent work accidents.

The cloning tool must be grounded through the centralised circuit of the place of installation.

Warning:



Make sure that the main voltage is compatible with the cloning tool voltage.

Make sure that the motive power outlets are grounded.

Warning:



Do not touch the cloning tool when your hands and/or feet are wet or humid;

Avoid any contact with grounded plates.

6.1.0 INSTRUCTIONS FOR THE OPERATOR

This section contains comprehensive instructions on how to detect, identify, read and duplicate a transponder key (or remote control).

6.1.1 GENERAL INSTRUCTIONS FOR USE

The following is a list of instructions that operators must follow in order to guarantee steadily efficient and safe cloning tool operations.

- The cloning tool must be kept away from electronic equipments;
- Keep the power cable away from heat, humidity, oil, water and sharp cutting items;
- Do not expose the cloning tool to bad weather;
- Disconnect the cloning tool power cable from the main outlet before any maintenance or repair operation or whenever the cloning tool remains unused for a long time;
- Use only original spare parts.

Warning:



Follow safety instructions carefully.

6.1.2 PRELIMINARY CHECK-LIST AND START-UP

Before starting the cloning tool the operator must:

- Check that the power cable is properly connected to the outlet.
- Check that the cloning tool is placed on a flat surface;
- Carry out a visual inspection of the cloning tool to make sure that no part has been removed or modified.
- Check that the cloning tool and the surrounding area are clean and no clothes, tools, spare parts and other objects may hamper cloning tool operations.

6.2.0 SETTINGS

Ultegra 884 Decryptor is delivered ready for use and does not need to be adjusted or calibrated.

6.2.1 GETTING STARTED

Before starting the cloning tool connect it to the main outlet (100/220V) through the power supply unit that comes with the cloning tool.

Decryptor Ultegra 884 - Patent pending



6.3.0 HOW TO USE THE CLONING TOOL

6.3.1 DISPLAY

Easy messages will explain each step and guide the user throughout the key duplicating process.

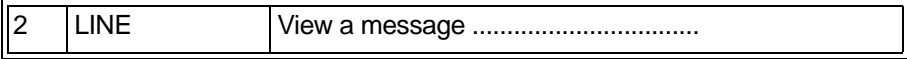
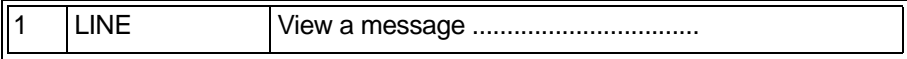

6.3.2 STARTING THE CLONING TOOL

To start the cloning tool, turn on the ON/OFF switch located in the rear of Ultegra 884 Decryptor.

6.3.3 SOFTWARE VERSION

When the device is turned on, the display will show, for a few seconds, the KL logo and then the following message:

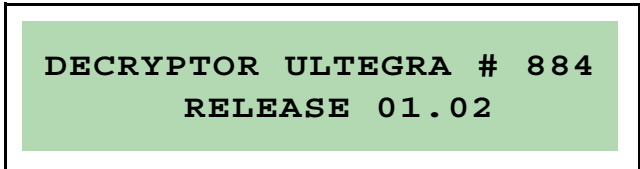

This screen provides information about the type of cloning tool you have and the software version installed in it.

6.3.4 TRANSPONDER READING (ON THE ORIGINAL KEY / REMOTE CONTROL)

The main page appears on the screen a few seconds after starting the cloning tool or upon pressing the "READ" button. It contains the following message:

**INSERT THE KEY
AND PRESS READ**

To read the transponder, insert the key to be "cloned" into the key insertion slot (A)



Confirm the 'reading' instruction by pressing the "READ" button:



The following message will appear on the display for a few seconds:

**READING IN PROGRESS
..... PLEASE WAIT**



Then, in the first line of the display you'll read the following identification data regarding the key transponder:

- Manufacturer (Philips*, Megamos*, Temic*, Texas*);
- Type;
- Model* (identified by a code, for instance: PH00).

The second line shows the instruction you need to follow in order to read the key:

```
TRANSP. PHILIPS PH00
PRESS READ
```

*Philips, Megamos, Temic and Texas Instruments are registered trademarks



***To identify the transponder MODEL refer to table 2 on page 54.**

If the identified transponder has a "fixed code", press the "READ" button to view the code contained in the key transponder.



CODES: AN EXAMPLE

```
2E13 F724 2080 10E2
E400 0000 0000 8180
```

If the transponder is missing or unknown one of the following messages will appear:

```
NO TRANSP. FOUND
PRESS READ
```

UNKNOWN TRANSPONDER
PRESS READ



For troubleshooting and solutions refer to paragraph 6.17.0. on page 53.

After the reading phase is complete, you can remove the key..

6.4.0 CLONING THE FIXED CODE TRANSPONDER

After the Ultegra 884 Decryptor has read and displayed the fixed code transponder code, insert a KeyLine read and write-type transponder key and press the **“WRITE”** button:



The following message will appear on the display for a few seconds:

WRITING IN PROGRESS
..... PLEASE WAIT

If writing is successful, the following message will appear:

WRITING SUCCESSFUL
PRESS READ/WRITE

Press the **“READ”** button to return to the main page; press the **“WRITE”** button and you will proceed with a second cloning, if requested. The following message will appear in case errors occur while the transponder is being written:

WRITING ERROR
PRESS READ/WRITE



For problem solving hints refer to paragraph 6.17.0. on page 53.

6.5.0 CLONING OF KEYS WITH PHILIPS PH (33) TRANSPONDER (USING THE KEYLINE TK5/TK100 ELECTRONIC HEAD)

The main page appears on the screen a few seconds after starting the cloning tool. It contains the following message:

**INSERT THE KEY
AND PRESS READ**

1. Insert the original key and press the "READ" button



2. The following message will appear on the display for a few seconds:

**READING IN PROGRESS
..... PLEASE WAIT**

3. If the key identification is displayed on screen as PH00/PH1A/MG00/TM10/TM20, it is possible to proceed with the following step:

**TRANSP. PHILIPS PH00 (33)
PRESS WRITE**

4. Leave the original key in the 884 "READ-WRITE insertion slot" and press the "WRITE" button.



5. The following message will appear:

**INSERT COPY KEY
PRESS WRITE**

6. Pull out the original transponder key, insert the new KEYLINE TK5 and press "WRITE". Wait until the following message appears on the screen:

**WRITING IN PROGRESS
PLEASE WAIT**

7. If the process is completed successfully, the following message shall be displayed:

**SUCCESSFUL WRITING
PRESS READ/WRITE**

8. Remove the original key and insert the TK5/TK100 with the KEYLINE "HorseShoe" used to duplicate the customer's original key blade



9. Now the KeyLine key with TK5 is ready to be used.

6.6.0 CLONING OF KEYS WITH TEXAS FISSO TX00 TRANSPONDER (USING THE KEYLINE TK24/TK100 ELECTRONIC HEAD)

The main page appears on the screen a few seconds after starting the cloning tool. It contains the following message:

**INSERT THE KEY
AND PRESS READ**

1. Insert the original key and press the "READ" button



2. The following message will appear on the display for a few seconds:

**READING IN PROGRESS
..... PLEASE WAIT**

3. If the key identification is displayed on screen as TEXAS® TX00, it is possible to proceed with the following step:

**TRANSP. TEXAS TX00-C4
PRESS WRITE**

4. Leave the original key in the 884 "READ-WRITE insertion slot" and press the "WRITE" button.





5. The following message will appear:

**INSERT COPY KEY
PRESS WRITE**

6. Pull out the original transponder key, insert the new KEYLINE TK24/TK100 and press "WRITE". Wait until the following message appears on the screen:

**WRITING IN PROGRESS
PLEASE WAIT**

7. If the process is completed successfully, the following message shall be displayed:

**SUCCESSFUL WRITING
PRESS READ/WRITE**

8. Remove the original key and insert the TK24/TK100 with the KEYLINE "HorseShoe" used to duplicate the customer's original key blade



9. Now the KeyLine key with TK24/TK100 is ready to be used.

6.7.0 CLONING OF KEYS WITH TEXAS* CRYPTO 1, 2 & 3 TRANSPONDER (USING THE KEYLINE TK40/TK100 ELECTRONIC HEAD)

The main page appears on the screen a few seconds after starting the cloning tool. It contains the following message:

**INSERT THE KEY
AND PRESS READ**

1. Insert the original key and press the "READ" button



2. The following message will appear on the display for a few seconds:

**READING IN PROGRESS
..... PLEASE WAIT**

3. If the key identification is displayed on screen as TEXAS® CRYPTO TPXX, it is possible to proceed with the following step:

**TEXAS CRYPTO TPXX
PRESS WRITE**

4. Leave the original key in the 884 "READ-WRITE insertion slot" and press the "WRITE" button.





5. You will be asked to program the key. To continue, press "WRITE" (YES) again:

```
PROG. CRYPTO KEY?  
RD = NO           WR = YES
```

6. Wait for the processing to end (max. 5 minutes):

```
CALCULATING ...  
PLEASE WAIT           03
```

7. When the calculation is completed, the following message will appear:

```
INSERT TK40 / 100  
PRESS WRITE
```

8. Remove the original key and insert the TK40 / 100, then press "WRITE" and wait for the end of the process:

```
WRITING IN PROGRESS  
PLEASE WAIT
```

9. If the process is completed successfully, the following message shall be displayed:

```
SUCCESSFUL WRITING  
PRESS READ/WRITE
```

- Press “READ” to go back to the main screen;
- Press “WRITE” to make other copies of the TK40 / TK100. If you proceed, the writing message shall be displayed again:

**WRITING IN PROGRESS
PLEASE WAIT**

The following message will appear in case an error occurs during the key writing:

**WRITING ERROR
PRESS READ/WRITE**

Check the type of key into the reader, press READ to go out or WRITE to start writing again.

10. Remove the original key and insert the TK40/TK100 with the KEYLINE “HorseShoe” used to duplicate the customer’s original key blade



11. Now the KeyLine key with TK40/TK100 is ready to be used.

6.8.0 CLONING OF KEYS WITH PHILIPS CRYPTO I TRANSPONDER (USING THE KEYLINE TK50/TK100 ELECTRONIC HEAD)

The main page appears on the screen a few seconds after starting the cloning tool. It contains the following message:

**INSERT THE KEY
AND PRESS READ**

1. Insert the original key and press the "READ" button



2. The following message will appear on the display for a few seconds:

**READING IN PROGRESS
..... PLEASE WAIT**

3. If the key identification is displayed on screen as PH1B/PH1D/PH1E, it is possible to proceed with the following step:

**TRANSP. PH1B
PRESS WRITE**

4. Press the Write key to start the transponder duplication procedure. The following message shall be displayed:

**INSERT COPY KEY
PRESS WRITE**

5. Press the "WRITE" key again and the following message shall be displayed:

DO NOT REMOVE THE KEY
PLEASE WAIT

6. Wait for a few seconds, until the following message is displayed:

INSERT COPY KEY
PRESS WRITE

7. Pull out the original transponder key, insert the new KEYLINE TK50 and press "WRITE". Wait until the following message appears on the screen:

SUCCESSFUL WRITING
PRESS READ/WRITE

8. Assemble the TK50/TK100 with the KEYLINE "HorseShoe" used to duplicate the customer's original key blade



9. Now the KeyLine key with TK50/TK100 is ready to be used.



At point 5, DO NOT REMOVE the original key for any reason, until the message mentioned in item 6 is displayed, asking for the new key to be inserted, other wise the original shall no longer be usable to operate the car.

6.9.0 CLONING OF TRANSPONDER KEYS WITH PHILIPS® CRYPTO PH20 TRANSPONDER (USING TK60 / TK100)

The main page appears on the screen a few seconds after starting the cloning tool. It shows the following message:

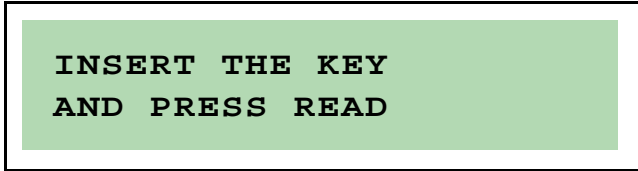

INSERT THE KEY
AND PRESS READ

1. Insert the original transponder key to be cloned into the 884 "READ-WRITE insertion slot" and press the "READ" button:



2. The following message will appear on the display for a few seconds:



READING IN PROGRESS
. . . . PLEASE WAIT

3. If the transponder identification is displayed on screen as PHILIPS® CRYPTO PH20, it is possible to proceed with the following step:

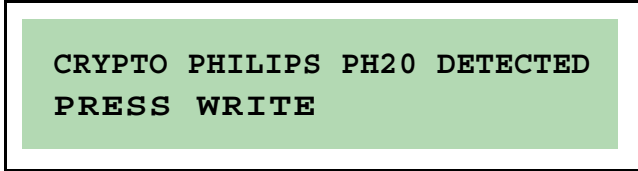

CRYPTO PHILIPS PH20 DETECTED
PRESS WRITE

4. Leave the original key in the 884 "READ-WRITE insertion slot" and press the "WRITE" button.



5. The following message will appear.

INSERT RK60/TK60/100
PRESS WRITE

6. Pull out the original transponder key, insert the new KEYLINE TK60 / TK100 and press "WRITE". Wait until the following message appears on the screen:

TK60 / TK100 STEP 1 COMPLETE
PRESS READ

7. Assemble the KEYLINE TK60 / TK100 with the KEYLINE horseshoe used to duplicate the customer's original key blade



8. Duplicate the metal section of the original key using the KEYLINE equivalent horse-shoe key. Use the TK60 / TK100 key to turn the car's ignition to the ON position three times (see note).

Warning:



For Renault cars, during the "8" phase, between one ignition of the electric panel and another using the TK60 / TK100 key, use the original key to turn the ignition in the ON position. Failing to do so would lead to a blockage of the control unit, which in turn shall require a disconnection of the car's battery for at least 20 minutes.

9. Insert the TK60 / TK100 key into the 884 "READ-WRITE insertion slot" and press "READ".



10. The following message will appear:

```
STEP 2 READ COMPLETE  
PRESS WRITE
```

11. Press the "WRITE" button.



12. You will be asked to proceed with the programming of the KeyLine key with TK60 / TK100. To proceed, press "WRITE" again:

```
PROG. CRYPTO KEY?  
RD = NO          WR = YES
```

13. Now extract the KeyLine duplicated key, insert the original key as requested and press "WRITE":

```
INSERT ORIGINAL KEY  
PRESS WRITE
```

14. Wait for the process calculating to end (max. 3 minutes):

```
CALCULATING ...  
PLEASE WAIT          03
```

15. When the calculation is completed, the following message will appear:

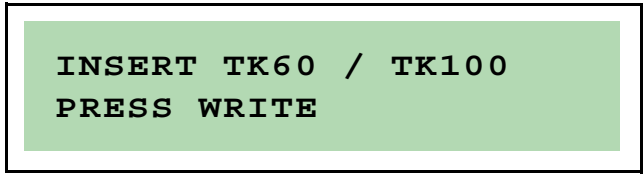

16. Now pull out the original key, insert the TK60 / TK100 KeyLine key and press "WRITE". Wait until the following message appears:

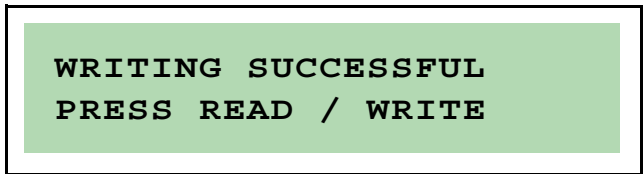

17. Now the TK60 / TK100 KeyLine key is ready for use.



CLONING SEQUENCE



Decryptor Uitegra 884 - Patent pending

6.10.0 CLONING OF REMOTE CONTROLS WITH PHILIPS® CRYPTO PH20 TRANSPONDER (USING RK60)

The main page appears on the screen a few seconds after starting the cloning tool. It shows the following message:

INSERT THE KEY
AND PRESS READ

1. Insert the original remote controls to be cloned into the 884 "READ-WRITE insertion slot" and press the "READ" button:



2. The following message will appear on the display for a few seconds:

READING IN PROGRESS
..... PLEASE WAIT

3. If the remote control identification is displayed on screen as PHILIPS® CRYPTO PH20, it is possible to proceed with the following step:

CRYPTO PHILIPS PH20 DETECTED
PRESS WRITE

4. Leave the original remote controls in the 884 "READ-WRITE insertion slot" and press the "WRITE" button.



5. The following message will appear.

INSERT RK60/TK60/100
PRESS WRITE

6. Pull out the original remote controls, insert the new KEYLINE RK60 and press "WRITE". Wait until the following message appears on the screen:

RK60 STEP 1 COMPLETE
PRESS READ

7. Assemble the KEYLINE RK60 with the KEYLINE horseshoe used to duplicate the customer's original key blade



8. Duplicate the metal section of the original key using the KEYLINE equivalent horse-shoe key. Use the TK60 key to turn the car's ignition to the ON position three times (see note).

Warning:



For Renault cars, during the "8" phase, between one ignition of the electric panel and another using the RK60 key, use the original key to turn the ignition in the ON position. Failing to do so would lead to a blockage of the control unit, which in turn shall require a disconnection of the car's battery for at least 20 minutes.

9. Insert the RK60 key into the 884 "READ-WRITE insertion slot" and press "READ".



10. The following message will appear:

**STEP 2 READ COMPLETE
PRESS WRITE**

11. Press the "WRITE" button .



12. You will be asked to proceed with the programming of the KeyLine key with RK60. To proceed, press "WRITE" again:

**PROG. CRYPTO KEY?
RD = NO WR = YES**

13. Now extract the KeyLine duplicated key, insert the original key as requested and press "WRITE":

**INSERT ORIGINAL KEY
PRESS WRITE**

14. Wait for the process calculating to end (max. 3 minutes):

**CALCULATING . . .
PLEASE WAIT 03**

15. When the calculation is completed, the following message will appear:



PUSH OPEN BUTTON

16. Hold the open button on the remote control of the original key until the following message:



PUSH CLOSE BUTTON

17. Hold down the lock button on the remote control of the original key until you see this message:



PUSH TRUNK BUTTON

18. Press trunk button on the remote control of the original key. If the remote does not have this button, press open button or close button until this screen appears:

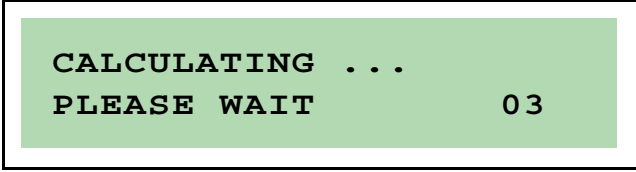

CALCULATING ...
PLEASE WAIT 03

19. When the calculation is completed, the following message will appear:

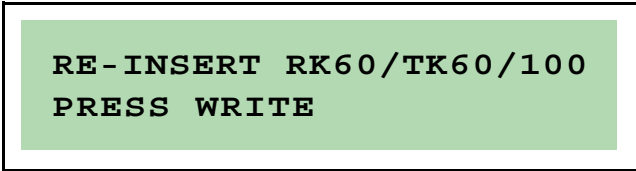

RE-INSERT RK60/TK60/100
PRESS WRITE

20. Now pull out the original key, insert the RK60 KeyLine key (used in the previous steps) and press "WRITE". Wait until the following message appears:

**SUCCESSFUL WRITING
PRESS READ/WRITE**

21. Now you go near the car and press open button two times, open the car manually or with the original remote

22. Turn on the car with RK60

23. Get off the car and verify RK60

24. Now the RK60 KeyLine key is ready for use.



Decryptor Ultegra 884 - Patent pending

6.11.0 CLONING OF KEY/REMOTE CONTROLS WITH PHILIPS® CRYPTO PH20 TRANSPONDER (USING RK60 - FIAT PANDA)

The main page appears on the screen a few seconds after starting the cloning. It contains the following message:

**INSERT THE KEY
AND PRESS READ**

1. Insert the original key to be cloned into the 884 and press the "READ" button:



2. The following message will appear on the display for a few seconds:

**READING IN PROGRESS
.... PLEASE WAIT**

3. If the key/remote control identification is displayed on screen as PHILIPS® CRYPTO PH20, it is possible to proceed with the following step:

**CRYPTO PHIL. PH20 (46)
PRESS WRITE**

4. Leave the original key in the 884 and press the "WRITE" button.



5. The following message will appear.

INSERT NEW RK60/TK60/100
PRESS WRITE

6. Pull out the original key, insert the new RK60 and press "WRITE".
Wait until the following message appears on the screen:

RK60/TK60/100 STEP 1 COMPLETE
PRESS READ

7. Assemble the KEYLINE TK60 with the KEYLINE "HorseShoe" used to duplicate the customer's original key blade



8. Duplicate the metal section of the original key using the KEYLINE equivalent horse-shoe key. Use the TK60 / TK100 key to turn the car's ignition to the ON position three times (see note).

Warning:



For Renault cars, during the "8" phase, between one ignition of the electric panel and another using the RK60 key, use the original key to turn the ignition in the ON position. Failing to do so would lead to a blockage of the control unit, which in turn shall require a disconnection of the car's battery for at least 20 minutes.

9. Insert the KeyLine RK60 key into the 884 and press "READ".



10. The following message will appear:

```
RK60/TK60/100 STEP 2  
PRESS WRITE
```

11. Press the "WRITE" button.



12. You will be asked to proceed with the programming of the KeyLine key with RK60. To proceed, press "WRITE" again:

```
PROG. CRYPTO KEY?  
RD = NO          WR = YES
```

13. Now extract the KeyLine duplicated key, insert the original key as requested and press "WRITE":

```
INSERT ORIGINAL KEY  
PRESS WRITE
```

14. Wait for the process calculating to end (max. 3 minutes):

```
CALCULATING ...  
PLEASE WAIT          03
```



15. When the calculation is completed, If you insert a key without a remote control, the following message will appear:

```
INSERT RK60/TK60/100  
PRESS WRITE
```

16. However, if you have inserted a key with remote control, the following screen will be visualized:

```
OPERATE THE REMOTE CONTROL 01
```

17. Hold the open button on the remote control of the original key until the following message:

```
RELEASE REMOTE CONTROL
```

18. Release the button on the remote control of the original key and if the message "Operate remote control XX" appears again, repeat from step 16 until you get the following Message:

```
CALCULATING . . .  
PLEASE WAIT
```

19. When the calculation is completed, the following message will appear:

```
INSERT RK60/TK60/100  
PRESS WRITE
```

20. Insert the RK60 KeyLine key, press "WRITE" and wait until the following message appears:

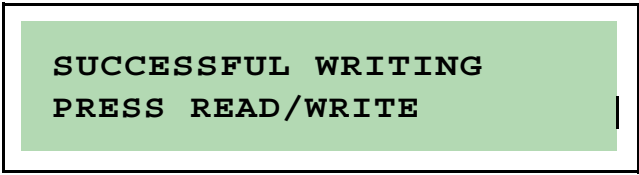

21. Now you go near the car and press RK60 open button two times.

22. Turn on the car with RK60.

23. Get off the car and verify the control remote.

24. Now the RK60 KeyLine key is ready for use.

CLONING SEQUENCE

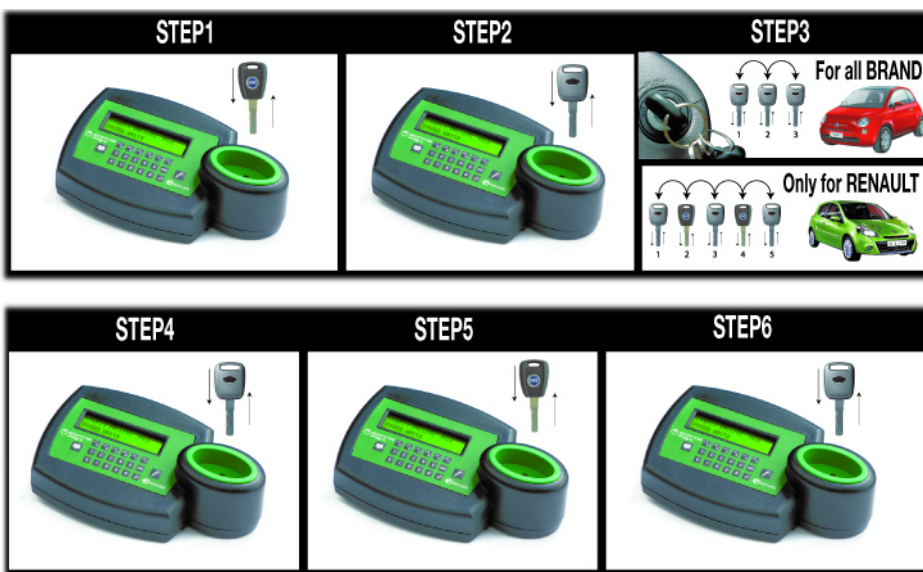

Decryptor Ultegra 884 - Patent pending



6.12.0 NEW FUNCTIONS FOR VERSION 02.030 - BI884

6.12.1 CODES GENERATION

The main page appears on the screen a few seconds after starting the cloning. It contains the following message:

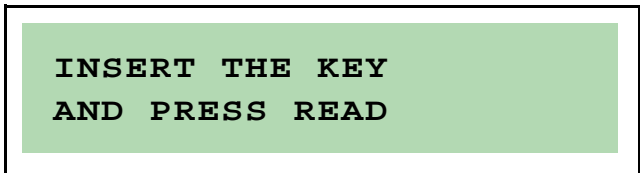

1. Press the "F3" button. The following message will appear:

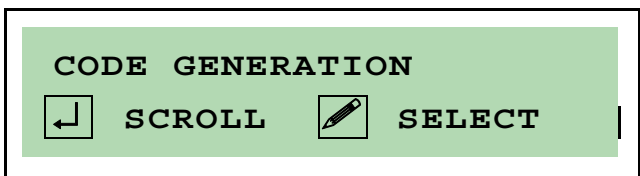

2. Press the "ENTER" key to scroll the list:



6.12.2 HOLDEN COMMODORE

Press the "WRITE" key to select:

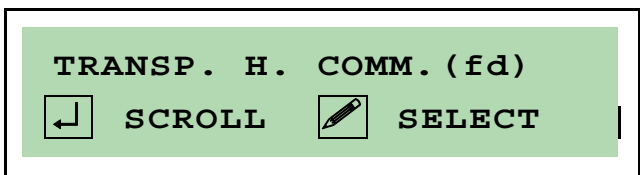

6.12.3 HOLDEN COMMODORE OLD

Press the "WRITE" key to select:

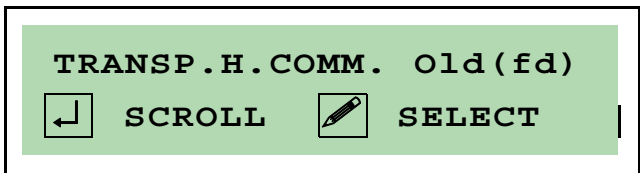

Input the code (maximum admissible code is 131071):

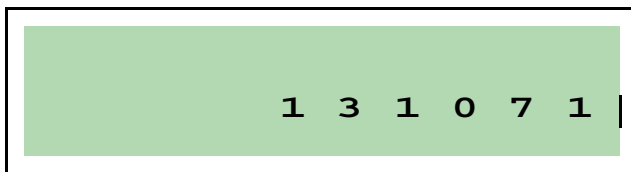

Insert the key in the 884 device and press "WRITE" to program the key. Wait until the following message is displayed:

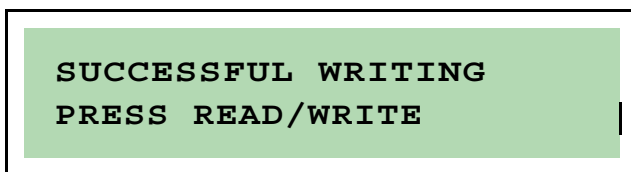

6.12.4 HOLDEN COMMODORE NEW

Press the "WRITE" key to select:

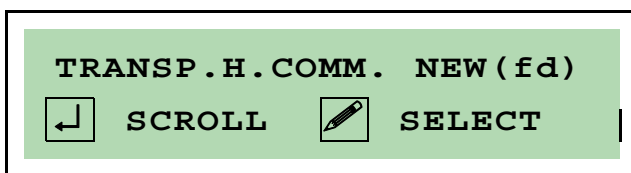

Use the numerical keypad to input the code (maximum admissible code is 131071) and save the key's position by pressing "F1":

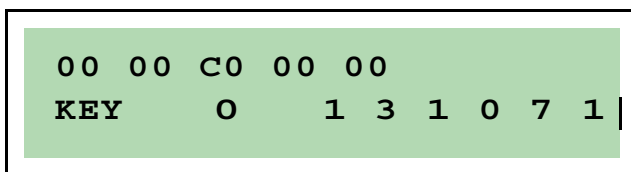

Insert the key in the 884 device and press "WRITE" to program the key. Wait until the following message is displayed:

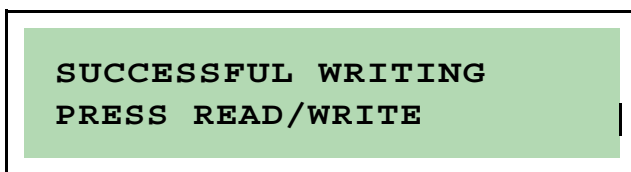



6.12.5 MEGAMOS MG00

Press the "WRITE" key to select (generic / VDO):

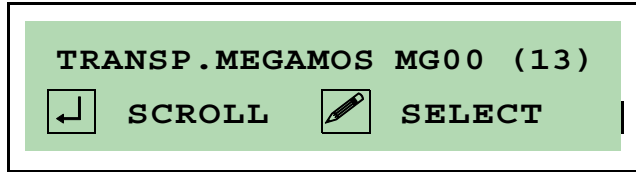

Use the numerical keypad to input the code or press "ENTER" (GENERATE) to generate a code automatically:

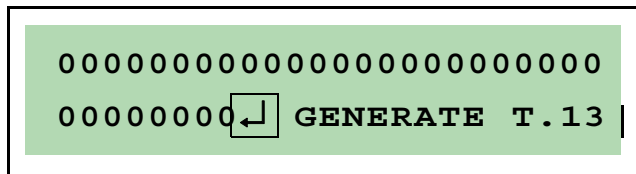

Insert the key in the 884 device and press "WRITE" to program the key. Wait until the following message is displayed:

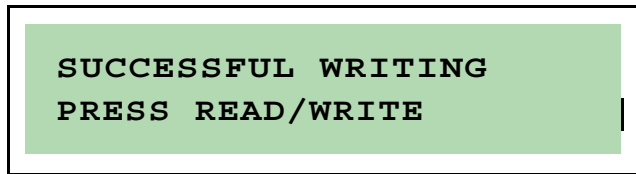

6.12.6 PHILIPS PH00

Press the "WRITE" key to select (FIAT/OPEL/VAG):



Use the numerical keypad to input the code or press "ENTER" (GENERATE) to generate a code automatically:

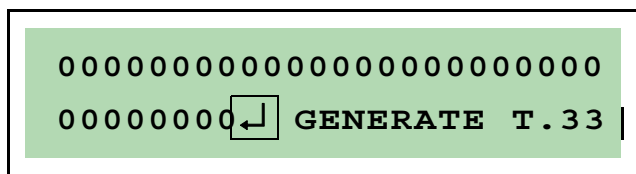

Insert the key in the 884 device and press "WRITE" to program the key. Wait until the following message is displayed:

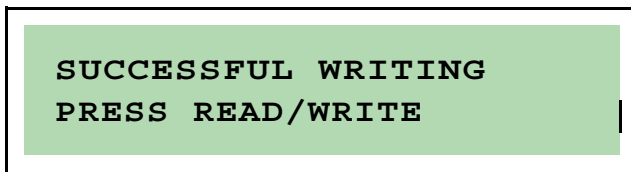

6.12.7 TEMIC TM10

Press the "WRITE" key to select (FIAT):

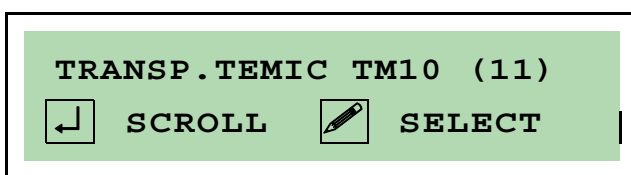

Use the numerical keypad to input the code or press "ENTER" (GENERATE) to generate a code automatically:

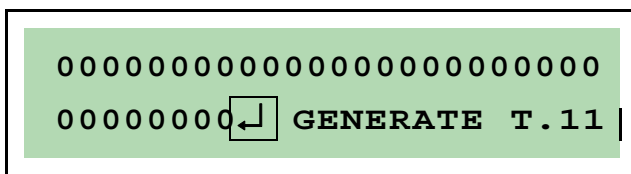

Insert the key in the 884 device and press "WRITE" to program the key. Wait until the following message is displayed:

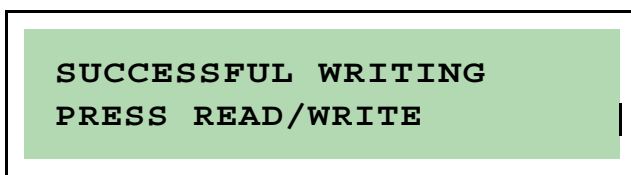

6.12.8 TEMIC TM20

Press the "WRITE" key to select:

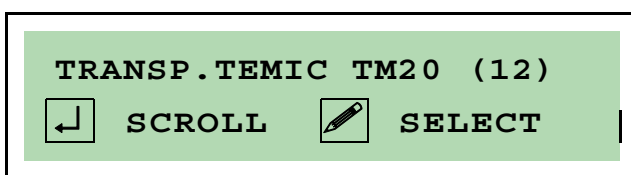

Decryptor Ultegra 884 - Patent pending

KEYLINE
PASSION FOR KEY INNOVATION



Use the numerical keypad to input the code:

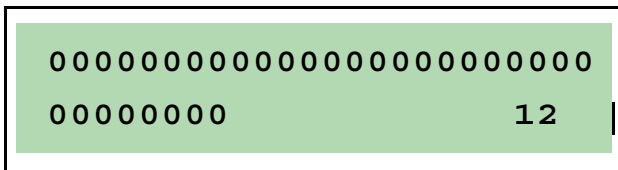

Insert the key in the 884 device and press "WRITE" to program the key. Wait until the following message is displayed:

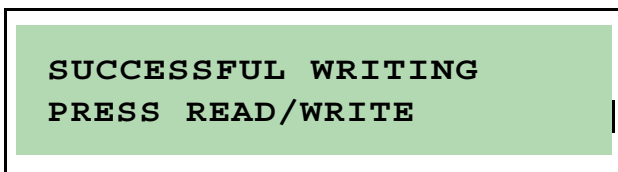

6.13.0 PROCEDURE FOR THE RECOVERY OF THE ORIGINAL KEYS PEUGEOT PH1D



If the original key is removed and the 884 device reset, or in case of a power failure during the analysis of the original PH1D key (the phase in which the device displays the "do not remove the key!" message), there is a procedure that can be used to recover the original key, which would otherwise remain damaged.

- 1. Insert the original key in the 884 device and press "read"; the following screen shall be displayed:

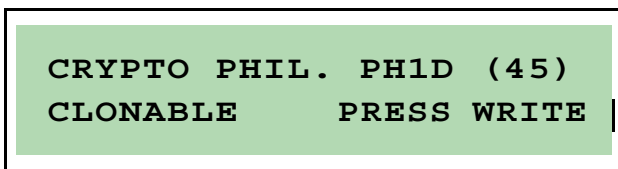

- 2. Press the "WRITE" key and the following screen shall be displayed:

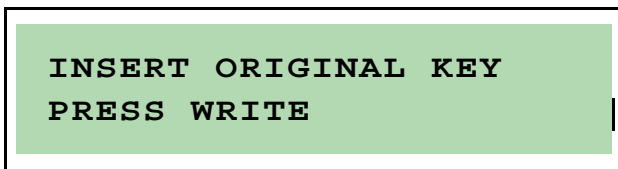

- 3. Keep the "F1" key pressed for 3 seconds and the following screen shall be displayed:

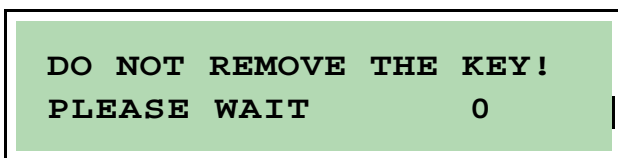

4. Do not remove the key from the 884 device at this point, wait for the following message to be displayed:

```
KEY GENERATED
PRESS READ
```

5. Now the key has been rewritten as it was originally.

6.14.0 CANCELLATION, IN ORDER TO USE TK60 / TK100 AGAIN

The TK60 / TK100 may be reused up to 10 times, the cancellation procedure is as follows:

1. Insert the TK60 / TK100 into the 884, and press "READ". The following message shall appear:

```
TK60 / TK100 - STEP 2
PRESS WRITE
```

2. Press "WRITE" and you will be instructed to proceed with the writing of the key:

```
PROG. CRYPTO KEY?
RD = NO           WR = YES
```

3. Now press "READ" (NO) and the following message shall appear:

```
DELETE KEY?
RD = NO           WR = YES
```

4. Confirm the cancellation by pressing "WRITE" (YES).

6.15.0 CANCELLATION, IN ORDER TO USE RK60 AGAIN

The RK60 may be reused up to 10 times, the cancellation procedure is as follows:

1. Insert the RK60 into the 884, and press "READ". The following message shall appear:

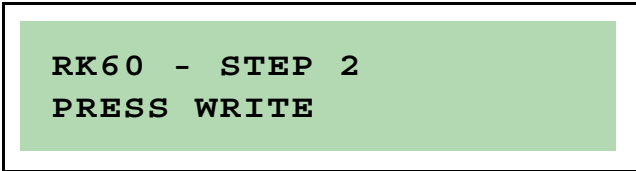

```
RK60 - STEP 2
PRESS WRITE
```

2. Press "WRITE" and you will be instructed to proceed with the writing of the key:



```
PROG. CRYPTO KEY?
RD = NO           WR = YES
```

3. Now press "READ" (NO) and the following message shall appear:

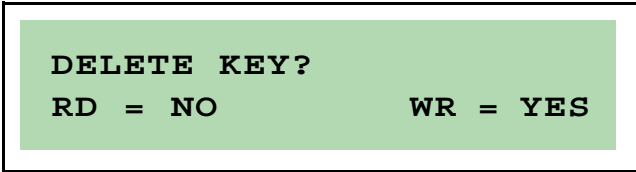

```
DELETE KEY?
RD = NO           WR = YES
```

4. Confirm the cancellation by pressing "WRITE" (YES).



6.16.0 LANGUAGE SETTING

You can set the language you wish to use following a few easy steps:

1. Turn on the device and press "F1" for two seconds;

The following screen will appear for a few seconds:

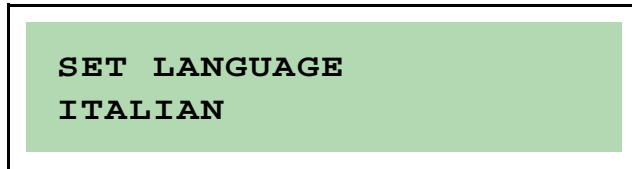

2. Press "READ" to view the languages available in **Ultegra 884 Decryptor**;



3. Once you have selected the language you wish to use (e.g. **ENGLISH**) press the "WRITE" button again;



4. The display will now show the main page in the selected language.

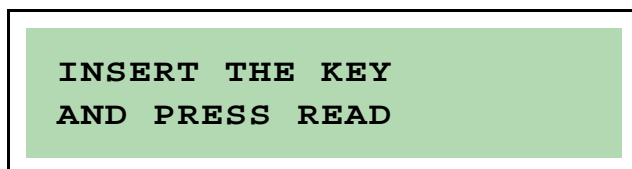



6.17.0 ERROR MESSAGES

The cloning tool is able to detect problems and anomalies that may occur while the key transponder is being read or written.

The following paragraphs provide a comprehensive list of situations when interruptions could occur and the error messages associated to them.

6.17.1 ERROR MESSAGES DURING READING

If problems occur while the transponder is being read, the system will deliver the following error messages.

NR	MESSAGE	MEANING	SOLUTION/CONSEQUENCE
1	NO TRANSPONDER FOUND	The key sample does not contain any transponder or hasn't been inserted properly	Try to read the transponder in a different position
2	TRANSPONDER UNKNOWN	The key transponder has not been identified by the cloning tool	The transponder cannot be identified

6.17.2 ERROR MESSAGES DURING WRITING

If problems occur while the transponder is being written, the system will deliver the following error messages.

NR	MESSAGE	MEANING	SOLUTION
1	NO TRANSPONDER DETECTED	The key blank does not contain any transponder or hasn't been inserted properly	Try to write a different key
2	WRITING ERROR	The transponder on the key blank is not compatible with the one required to obtain a duplicate The transponder on the key blank is damaged or it cannot be written properly or it is protected and writing is not allowed	Repeat the writing operation on a different key

6.18.0 TRANSPONDER IDENTIFICATION

The cloning tool can identify all the transponder types indicated into the following table.



Pay attention to the “Philips crypto”: PH10 - PH1A - PH1B - PH1C - PH1D transponders because they work with fixed code and with crypto code too. In this case it is possible to clone only the fixed code but this does not guarantee the car correct functioning.

Before cloning these models it is suggested to verify if the car provides fixed code immobilizer system.









TYPE	ID	DESCRIPTION	SYMBOL
PHILIPS*	PH00	FIXED CODE	
	PH10	CRYPTO	
	PH1A	CRYPTO FOR OPEL	
	PH1B	CRYPTO FOR NISSAN - FORD	
	PH1C	CRYPTO FOR VAG	
	PH1D	CRYPTO FOR PEUGEOT	
	PH20	CRYPTO 2 FOR PSA - FIAT - FORD	
TEMIC*	TM10	FIXED CODE FOR FIAT	
	TM20	FIXED CODE FOR MAZDA	
	TM01	CRYPTO FOR MAZDA	
MEGAMOS*	MG00	FIXED CODE	
	MG10	CRYPTO FOR VAG	
TEXAS*	TX00	FIXED CODE	
	TC01	CRYPTO FOR FORD - NISSAN	
	TC02	CRYPTO	
	TC03	CRYPTO FOR FORD	
	TC04	CRYPTO FOR OPEL - RENAULT SUBARO - HYUNDAI - LINCOLN - CHRYSLER - JEEP - DODGE - EAGLE	
	TC05	CRYPTO FOR FORD	
	TC06	CRYPTO FOR FORD	
	TC07	CRYPTO FOR MITSUBISHI - NISSAN	
	TP01	CRYPTO W1 FOR FORD	

Table 2: Transponder table

*Philips, Megamos, Temic and Texas Instruments are registered trademarks



6.19.0 UPDATING THE SOFTWARE

The versatile features of the latest generation's microprocessors allow Ultegra 884 Decryptor to evolve and remain up-to-date.

To update the software you need to connect the Ultegra 884 Decryptor cloning tool to a Personal Computer or Notebook.

PROCEDURE:

1. Load the disk 884 in the computer;
2. Connect the Personal Computer or Notebook to the Ultegra 884 Decryptor by means of an USB cable as shown in figure 5;
3. Go to the "MY COMPUTER" folder of your Personal Computer or Notebook, where the "DISK884" unit shall be displayed;
4. Copy the update file in the "DISK884" unit;
5. The following message shall be displayed:

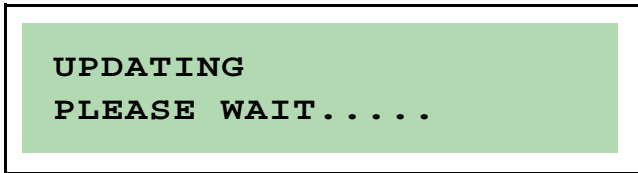

6. Wait until the device reboots; once the start message is displayed, you can proceed with the normal reading and cloning activities.



Figura 5: Personal Computer or Notebook connection

The Ultegra 884 Decryptor cloning tool is easy to use and well built and does not need any special maintenance.

This chapter contains only some general maintenance instructions.

7.1.0 GENERAL INFORMATION

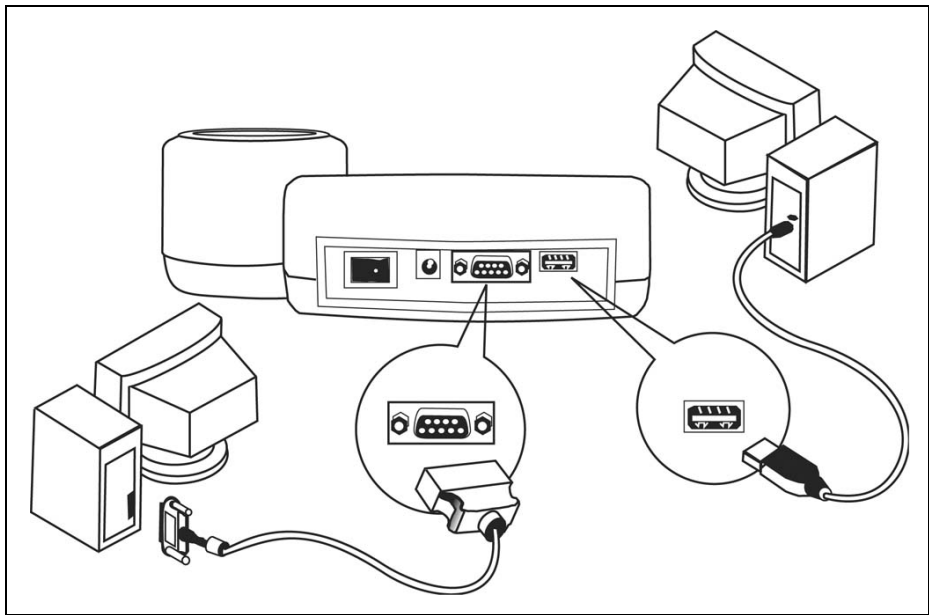
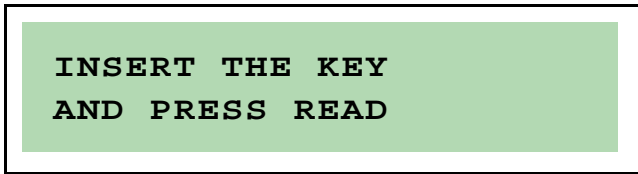
7.1.1 SKILLS OF MAINTENANCE PERSONNEL

Maintenance personnel must have specific theoretical and practical skills, that is, they must be qualified.

OPERATOR

The machine operator must be knowledgeable about cloning tool operation.

PERSONNEL AUTHORIZED BY KEYLINE S.p.A.

Personnel from **KeyLine S.p.A.** Technical Support Service or else officially authorised by **KeyLine S.p.A.** Technical Support Service.



8.0.1 WASTE DISPOSAL

The disposal of waste generated by the cloning tool shall be managed in compliance with the legislation in force in the user's country. In Europe machine shop rejections are classified as special waste and are assimilated to metal wool when it comes to managing municipal solid waste (MSW).

Such waste must be disposed of according to the legislation in force in the user's country. If machine shop rejections have been contaminated or contain toxic or harmful substances they are considered as toxic -harmful waste and disposed of accordingly in compliance with the legislation in force.

The user is responsible for a correct waste management.

8.0.2 DISPOSAL OF THE PACKING MATERIAL

Our key duplicating machines are delivered in cardboard packages that can be recycled as packing material.

In case of disposal, packing material is treated as municipal solid waste (MSW) and is usually collected together with paper materials. Protective covers are made of polystyrene and must be sent to suitable waste disposal sites as other municipal solid waste of the same type.

8.1.0 THE WEEE DIRECTIVE

When disposal becomes necessary, the **Ultegra 884 Decryptor** is to be considered as belonging to the WEEE category (Waste Electrical and Electronic Equipment).

KeyLine S.p.A. has always taken great care to protect the environment and complies with the legislative decree on WEEE that has been in force since 13/08/2005. As a consequence, in accordance with the prescriptions of directive 2002/96/CE, this appliance cannot be disposed of as household waste (in compliance with the special symbol shown below).



- Whoever disposes of this cloning tool illegally or as household waste will be subject to the sanctions foreseen by current national legislation.
- According to the provisions of current national legislation, this cloning tool cannot be disposed of as household waste. Therefore, at the end of its lifecycle, after having carried out the operations that are necessary for correct disposal, the cloning tool must be taken to one of the differentiated waste collection centres for electrical and electronic waste from domestic households. Refer to the collection centre in your own town, which will guarantee the functionality, accessibility and suitability of the differentiated collection systems, so that the final holder and distributors can take the waste that they produce in their area to collection centres, free of charge.

