



PACK MULE

INDUSTRIAL ELECTRIC VEHICLE



OWNER'S MANUAL AND SERVICE GUIDE

SC & SCT SERIES
APRIL 2014

FOREWARD

UPON RECEIPT OF VEHICLE/EQUIPMENT:

Please visually inspect the vehicle for any damage that may have occurred during shipping and have it noted on the carrier's bill immediately. Be sure to specify the nature of the damage.

This manual is a VERY IMPORTANT tool. Please keep it with the vehicle/equipment at all times. The purpose of this manual is to provide owner, users, lessors and/or lessees with the operating instructions and precautions for the safe and proper operation of the vehicle or equipment. It is the owner, user, lessor or lessees responsibility to ensure that the vehicle/equipment is being used in accordance with its designed intended use.

Please read this ENTIRE manual to familiarize yourself with the safe operation of this vehicle/equipment. Pay particular attention to anything labeled CAUTION, NOTE, OR WARNING!

Due to continuous product improvements, changes or updates may be made to this manual, making it subject to change without notice. For the most up to date version of the manual, please go to our website: <http://www.packmule.com/support/product-manuals/> OR call Wesley International at: 1-800-241-2869.

The Pack Mule Division of Wesley International, reserves the right to incorporate engineering and design changes to products in this manual without any obligation to include these changes on any units/vehicles already purchased or leased.

The Pack Mule Division and/or Wesley International accepts no liability in connection with any errors or omissions in this manual, and SPECIFICALLY DISCLAIMS any liability for any incidental and consequential damages arising from the use of the information in this Manual.

The use of non OEM (Original Equipment Manufacturer) parts may void the warranty.

Overfilling the batteries may void your warranty.

NOTES, CAUTIONS AND WARNINGS

Throughout this guide NOTE, CAUTION, and WARNING will be used. Please observe these notes, cautions and warnings.

NOTE

A NOTE indicates a condition that should be observed.

CAUTION

A CAUTION indicates a condition that may result in damage to the vehicle.

WARNING

A WARNING indicates a hazardous condition that could result in severe injury or death.

TABLE OF CONTENTS

INTRODUCTION	5
SAFETY INFORMATION.....	6
Training.....	6
Operator Qualifications	6
Safety Guidelines.....	6
Loading and Unloading.....	7
Towing	7
Maintenance	7
Ventilation.....	7
Industry Standards.....	8
OPERATING INSTRUCTIONS.....	12
Initial Checklist.....	12
Identification.....	12
Charging	12
Vehicle Controls, Meters, Switches	12
Driving	17
Coasting	17
Loading/Unloading.....	17
Parking	17
Towing	17
Startup Checklist for Industrial Truck.....	18
MAINTENANCE INSTRUCTIONS.....	19
Maintenance Schedule	19
Routine Maintenance.....	20
Batteries	20
Battery Safety	20
Battery Care.....	20
Electrolyte Levels.....	21
Battery Watering System	21
Cleaning Batteries	21
Battery Replacement	21
Lifting the Vehicle	22
Lubrication	22
Brakes	23
Tires and Wheels.....	23
COMPONENTS - ELECTRICAL.....	25
Basic Electrical Components	25
Onboard Battery Charger	26
Motor	28
Controller	28

Battery Discharge Indicator (BDI)	33
Throttle Position Device	33
Solenoid.....	33
Wiring Diagram	34
Parts List – Electrical	35
Parts List – Available Options.....	36
COMPONENTS - MECHANICAL	37
Parts List – Front Wheel Steer Assembly	37
Parts List - Accelerator Linkage.....	38
Transaxle Diagram for SC Series	39
Transaxle Parts List for the SC Series.....	40
Transaxle Diagram for SCT Series.....	41
Transaxle Parts List for the SCT Series.....	42
Optional Beacon for the SC Series.....	43

INTRODUCTION

Thank you for choosing a Pack Mule Industrial Electric Vehicle, proudly built by Wesley International in the USA. At Wesley International, we are committed to providing you the best quality product backed by exceptional customer service. This owner's manual and service guide is provided to help you get the most out of your new vehicle, for many years to come.

RECORD YOUR PRODUCT INFORMATION

Model #: _____ Serial #: _____

Purchase Date: _____

REGISTER YOUR PRODUCT

PRODUCT REGISTRATION IS REQUIRED FOR WARRANTY COVERAGE.

Registration is easy. Simply go to <http://www.packmule.com/support/warranty/> and complete the online form and click submit. That's it! Then you will be entitled to free parts for any defective items, as outlined in our warranty document.

IF YOU NEED HELP

You will find many answers to common problems within this manual or online at www.packmule.com. If you do not find what you need, we are always ready and willing to help. Just email us at info@wesleyintl.com or call (800) 241-2869 or (404) 292-7441.

Wesley International
3680 Chestnut Street
Scottsdale, GA 30079

Phone (404) 292-7441 • Toll Free (800) 241-2869 • Fax (404) 292-8469
info@wesleyintl.com
www.wesleyinternational.com

SAFETY INFORMATION

The responsibility of safety lies with four main groups: manufacturers, owners/lessees, operators and maintenance personnel. This manual has been designed to assist the owner-operator in operating and maintaining the vehicle in a safe manner, in accordance with the procedures and standards to which the vehicle was designed and intended for use.

TRAINING

Vehicle owners/lessees are responsible for instructing their personnel in its safe operation. Owners must explain the vehicle's characteristics, features, operation of its controls, and safe driving practices. We strongly recommend that owners first become familiar with the conditions of the place where the vehicle will be operated in order to assess its effect on safe operation. Training should occur under the conditions of the operating environment while adhering to the safety guidelines and include:

- Safety guidelines
- Operation of the vehicle under the conditions in which it will be operated
- Operation of all controls
- Safe driving practices
- A driving and operating test

OPERATOR QUALIFICATIONS

Operators should be selected based on their ability to safely operate the vehicle, including vision, hearing, physical and mental capabilities. Operators must:

- Demonstrate a working knowledge of all controls
- Understand all safety guidelines
- Be able to properly drive and park the vehicle under the conditions in which the vehicle will be used
- Know how to properly load and unload cargo and passengers
- Recognize maintenance problems

SAFETY GUIDELINES

All Pack Mule vehicles are designed for use on smooth surfaces in and around industrial plants, warehouses, nurseries and greenhouses. While made of components that are unaffected by the rain, they are not intended for continuous outdoor use, traversing up and down steep grades, or travelling on public roads/highways as the tires are not configured for these purposes.

Follow these guidelines to safely drive the vehicle:

- Read, understand and observe all labels affixed to the vehicle
- Do not start the vehicle without checking the brakes first
- Do not mount or dismount the vehicle when the key is in the ON position
- Do not drive the vehicle if the accelerator requires excessive pressure
- Do not park or operate the vehicle near flammable objects or in a flammable or hazardous environment
- Use only necessary power
- Keep both hands on the steering wheel while operating the vehicle
- Accelerate and decelerate slowly and in a controlled manner
- Always reduce speed to compensate for poor terrain or conditions
- Always maintain adequate distance between vehicles, people, and obstacles
- Do not use the vehicle to push objects
- Do not allow the tires to lose contact with the ground
- Proceed around low overhangs with caution. Be sure there is enough clearance for the operator's head and the highest point of the vehicle or any attached accessories.
- Never abruptly change direction
- Always drive directly up an incline; never across
- Never exceed the designated passenger, load or towing capacity

On grades, it is possible for vehicles to coast at greater than normal speeds encountered on a flat surface. To prevent loss of vehicle control and possible serious injury, speeds should be limited to no more than maximum speed on level ground.

Good common sense and prudent driving practices do more to prevent accidents and injuries than all of the warnings and instructions combined. Wesley International strongly suggests that the owner-operator read this entire manual paying particular attention to the CAUTIONS and WARNINGS contained therein.

SAFETY INFORMATION

Loading and Unloading

Follow these guidelines when loading and unloading cargo:

- Turn the vehicle off while loading
- Do not exceed the maximum passenger or cargo load capacity
- Carefully and evenly position all loads
- Secure cargo so that nothing can easily fall off of the vehicle
- Be extremely careful carrying loads that extend beyond the vehicle's deck

TOWING

Follow these guidelines when towing:

- Turn the vehicle off when connecting equipment that will be towed
- Always use a properly installed hitch (Optional hitches available from Wesley International)
- Do not exceed the maximum towing capacity
- Do not exceed 5 mph when towing
- Take extreme care when towing down an incline. Do not tow trailers down an incline with a grade of more than 15%.

MAINTENANCE

Always maintain your vehicle in accordance with the service schedule within this manual and keep complete records of the maintenance history of the vehicle. Ensure the maintenance personnel performing any service or repair work on the vehicle are trained and qualified to do so. Be sure to disable the vehicle before performing any maintenance including removing the key from the key switch and removal of a battery cable.

WARNING

Always insulate any tools used within the battery area in order to prevent sparks or battery explosion caused by shorting the battery terminals or associated wiring.

Be sure to check the polarity of each battery terminal and be sure to rewire the batteries correctly. Never install a wire instead of a proper fuse, even for a temporary fix. It may cause extensive damage and possible fire. Do not use a screwdriver or other metal object to remove fuses. Doing so may cause an electrical short and damage the system. Do not modify or tamper with any part of the operating or speed control systems. All inspections and adjustments must be made by a qualified technician.

Always support the vehicle using wheel chocks and safety stands. Never get under a vehicle that is supported by a jack. Lift the vehicle in accordance with the instructions in this manual.

Always test drive the vehicle after any repairs or maintenance in a safe area free of any other vehicles or pedestrians.

VENTILATION

WARNING

Hydrogen gas is generated in the charging cycle of batteries and is explosive in concentrations as low as 4%. Because hydrogen gas is lighter than air, it will collect in the ceilings of buildings and therefore, proper ventilation is required. Five air exchanges per hour is considered the minimum ventilation required.

Always use a dedicated circuit for each battery charger. Do not permit other appliances to be plugged into the receptacle when the charger is in operation.

INDUSTRY STANDARDS

The following text is provided as recommended by Part II, "For the User", of ANSI/ITSDF B56.8-2011, Safety Standard for Personnel and Burden Carriers. The manufacturer strongly endorses the contents of this specification.

6 GENERAL SAFETY PRACTICES

6.1 Introduction

6.1.1 Like other machines, carriers can cause injury if improperly used or maintained. Part II contains broad safety practices applicable to carrier operation. Before operation, the user shall establish such additional specific safety practices as may reasonably be required for safe operation.

6.1.2 Premise review — The user shall periodically review their premises, and as conditions warrant, identify areas where carriers should not be operated and to identify possible hazards such as the following examples:

(a) Steep Grade — In areas where steep grades exist, carrier operation should be restricted to the designated vehicle's pathways where possible, and shall be identified with a suitable warning giving the following information: "Warning, steep grade."

(b) Wet Areas — Wet areas could cause a carrier to lose traction and could affect steering, stability and braking.

(c) Sharp Turns, Blind Spots, Bridge Approaches — Sharp turns, blind spots, bridge approaches, and other potentially hazardous areas shall be identified with a suitable warning to the operator of the nature of the hazard and stating the proper precautions to be taken to avoid the hazard.

(d) Loose Terrain — Loose terrain could cause a carrier to lose traction and could affect steering, stability, and braking.

6.2 Operation

Experience has shown that carriers, which comply with the provisions, stated in paragraphs 9.4, 9.5, and 9.6 are stable when properly operated and when operated in accordance with specific safety rules and practices established to meet actual operating terrain and conditions. However, improper operation, faulty maintenance, or poor housekeeping may contribute to a condition of instability and defeat the purpose of the standard. Some of the conditions which may affect stability are failure of the user to follow safety practices; also, ground and floor conditions, grade, speed, loading, the operation of the carrier with improper loads, battery weight, dynamic and static forces, and the judgment exercised by the carrier operator.

(a) The user shall train carrier operators to adhere strictly to the operating instructions stated in this Standard.

(b) The user shall survey specific operating conditions and environment, and establish and train carrier operators to comply with additional, specific safety practices.

6.3 Nameplates, Markings, Capacity, and Modifications

6.3.1 The user shall maintain in a legible condition all nameplates, warnings, and instructions, which are supplied by the manufacturer.

6.3.2 Except as provided in 6.3.4, no modifications or alterations to a carrier, which may affect the capacity, stability, or safe operation of the carrier, shall be made without the prior written approval of the original carrier manufacturer or a successor thereof. When the carrier manufacturer or its successor approves a modification or alteration, appropriate changes shall be made to capacity plates, decals, tags, and operation and maintenance manuals.

6.3.3 As required under paragraphs 6.3.1 or 6.3.2, the manufacturer shall be contacted to secure new nameplates, warnings, or instructions, which shall then be affixed in their proper place on the carrier.

6.3.4 In the event that the carrier manufacturer is no longer in business and there is no successor in interest to the business, the user may arrange for a modification or alteration to a carrier, provided however, the controlling party shall:

(1) Arrange for the modification or alteration to be designed, tested, and implemented by an engineer(s) expert in carrier(s) and their safety;

(2) Maintain a permanent record of the design, test(s), and implementation of the modification or alteration;

(3) Make appropriate changes to the capacity plate(s), decals, tags, and operation and maintenance manuals;

(4) Affix a permanent and readily visible label on the carrier stating the manner in which the carrier has been modified or altered together with the date of the modification or alteration, and the name of the organization that accomplished the tasks.

6.4 Changing and Charging Storage Batteries for Electric Personnel and Burden Carriers

6.4.1 The user shall require battery changing and charging facilities and procedures to be in accordance with ANSI/NFPA 505 or as required by local ordinance.

6.4.2 The user shall periodically inspect facilities and review procedures to be certain that ANSI/NFPA 505 or as required by local ordinance, are strictly complied with, and shall familiarize carrier operators with it.

INDUSTRY STANDARDS

6.4.3 Maintenance and storage areas for carriers shall be properly ventilated to avoid fire hazards in accordance with applicable fire codes and ordinances.

Ventilation for internal combustion engine powered carriers shall be provided to remove flammable vapors (gases), fumes and other flammable materials. Consult applicable fire codes for specific levels of ventilation.

Ventilation for electric powered carriers shall be provided to remove the accumulation of flammable hydrogen gas emitted during the battery charging process.

The amount of hydrogen gas emitted depends upon a number of factors such as the condition of the batteries, the output rate of the battery charger and the amount of time the batteries are on charge. Because of the highly volatile nature of hydrogen gas and its propensity to accumulate in pockets, a minimum number of air changes per hour is required during charging.

Consult applicable fire and safety codes for the specific ventilation levels required as well as the use of explosion proof electrical apparatus. SAE J1718 can be followed to check for hydrogen gas levels.

6.5 Hazardous Locations

6.5.1 The user shall determine the hazard classification of the particular atmosphere or location in which the carrier is to be used in accordance with ANSI/NFPA 505.

6.5.2 The user shall permit in hazardous areas only those carriers approved and of the type required by ANSI/NFPA 505.

6.6 Lighting for Operating Area

The user, in accordance with his responsibility to survey the environment and operating conditions, shall determine if the carrier requires lights and, if so, shall equip the carrier with appropriate lights.

6.7 Control of Noxious Gases and Fumes

When equipment powered by internal combustion engines is used in enclosed areas, the atmosphere shall be maintained within limits specified in the American Conference of Governmental Industrial Hygienists publication, "Threshold Limit Values for Chemical Substances and Physical Agents in the Workroom Environment." This may be accomplished by ventilation provided by the user, or the installation, use, and proper maintenance of emission control equipment recommended or provided by the manufacturer of the equipment.

6.8 Warning Device(s)

6.8.1 The user shall make periodic inspections of the carrier to be certain that the sound-producing and/or visual device(s) if so equipped are maintained in good operating condition.

6.8.2 The user shall determine if operating conditions require the carrier to be equipped with additional sound producing or visual devices or both and be responsible for providing and maintaining such devices, in accordance with the manufacturer's recommendations.

6.9 Safety Interlocks

The user shall make periodic inspections of the carrier to be certain that the safety interlock system, if so equipped, is operating properly.

7 OPERATING SAFETY RULES AND PRACTICES

7.1 Personnel and Burden Carrier Operator Qualifications

Only persons who are trained in the proper operation of the carrier shall be authorized to operate the carrier. Operators shall be qualified as to visual, auditory, physical, and mental ability to safely operate the equipment according to Section 7, all other applicable parts of this Standard and the operators' manual.

7.2 Personnel and Burden Carrier Operators' Training

7.2.1 The user shall conduct an operators' training program.

7.2.2 Successful completion of the operators' training program by the operator shall be required before operation of the carrier. The program shall be presented in its entirety to all-new operators and not condensed for those claiming previous experience.

7.2.3 The user shall include as a minimum in the operators' training program the following:

- (a) Instructional material provided by the manufacturer including the operators' manual;
- (b) Emphasis on safety of passengers, material loads, carrier operator, and other person(s);
- (c) General safety rules contained within this Standard and the additional specific rules determined by the user in accordance with this Standard, and why they were formulated;
- (d) Introduction of equipment, control locations and functions, and explanation of how they work when used properly and when used improperly; and surface conditions, grade, and other conditions of the environment which could affect carrier operation;
- (e) Operator competency evaluations.

INDUSTRY STANDARDS

7.3 Personnel and Burden Carrier Operator Responsibility

7.3.1 General Operator Responsibility

7.3.1.1 Read and follow operators' manual.

7.3.1.2 Do not operate carrier under the influence of drugs and alcohol.

7.3.1.3 Safeguard the pedestrians at all times. Do not drive carrier in a manner that would endanger other persons.

7.3.1.4 Riding on the carrier by persons other than the operator is authorized only on personnel seat(s) provided by the manufacturer. All parts of each person's body shall remain within the plan view outline of the carrier.

7.3.1.5 When a carrier is to be left unattended, stop the carrier, apply the parking brake, stop the engine or turn off power, turn off the control or ignition circuit, and remove the key if provided. Additionally, for electric carriers, the forward and reverse directional controls, should be neutralized if a means is provided. Block the wheels if the carrier is on an incline.

7.3.1.6 A carrier is considered unattended when the operator is 7.6m (25 ft) or more from the carrier which remains in his view, or whenever the operator leaves the carrier and it is not within his view. When the operator is dismounted and within 7.6m (25 ft) of the carrier still in his view, he still must have controls neutralized, and the parking brake(s) set to prevent movement.

7.3.1.7 Maintain a safe distance from potential hazards, such as edges of ramps and platforms.

7.3.1.8 Use only approved carriers in hazardous locations, as defined in the appropriate safety standards.

7.3.1.9 Report all accidents to the user.

7.3.1.10 Do not add to, or modify, the carrier.

7.3.1.11 Carriers shall not be parked or left unattended such that they block or obstruct fire aisles, access to stairways, or fire equipment.

7.3.1.12 Only operate carrier while within operator's station.

7.3.2 Traveling

7.3.2.1 Observe all traffic regulations, including authorized speed limits. Under normal traffic conditions keep to the right. Maintain a safe distance, based on speed of travel, from a carrier or vehicle ahead; and keep the carrier under control at all times.

7.3.2.2 Yield the right of way to pedestrians, ambulances, fire trucks, or other carriers/vehicles in emergency situations.

7.3.2.3 Do not pass another carrier or vehicle traveling in the same direction at intersections, blind spots, or at other dangerous locations.

7.3.2.4 Keep a clear view of the path of travel, observe other traffic and personnel, and maintain a safe clearance.

7.3.2.5 Slow down or stop, as conditions dictate, and activate the sound-producing warning device at cross aisles and when visibility is obstructed at other locations.

7.3.2.6 Ascend or descend grades slowly.

7.3.2.7 Avoid turning, if possible, and use extreme caution on grades, ramps, or inclines; normally travel straight up and down.

7.3.2.8 Under all travel conditions the carrier shall be operated at a speed that will permit it to be brought to a stop in a safe manner.

7.3.2.9 Make starts, stops, turns, or direction reversals in a smooth manner so as not to shift the load, endanger passengers, or lose control of the carrier.

7.3.2.10 Do not operate carrier in a dangerous manner.

7.3.2.11 Slow down when approaching, or on, wet or slippery surfaces.

7.3.2.12 Do not drive carrier onto any elevator unless specifically authorized to do so. Approach elevators slowly, and then enter squarely after the elevator car is properly leveled. Once on the elevator, neutralize the controls, shut off power, and set parking brakes. It is advisable that all other personnel leave the elevator before a carrier is allowed to enter or exit.

7.3.2.13 Avoid running over loose objects, potholes, and bumps.

7.3.2.14 Reduce carrier speed to negotiate turns.

7.3.2.15 Avoid any action verbal or physical by an operator or passenger, which could cause the operator to be distracted.

7.3.3 Loading

7.3.3.1 Refer to operators' manual for loading instruction.

7.3.3.2 Handle only stable and safely arranged loads. When handling off-center loads, which cannot be centered, operate with extra caution.

7.3.3.3 Handle only loads within the capacity of each cargo area of the carrier as specified by the manufacturer.

7.3.3.4 Avoid material loads exceeding the physical dimensions of the carrier or as specified by the carrier manufacturer.

INDUSTRY STANDARDS

7.3.4 Operator Care of Personnel and Burden Carriers

7.3.4.1 Read and follow operators' manual.

7.3.4.2 At the beginning of each shift during which the carrier will be used, the operator shall check the carrier condition and inspect the tires, warning devices, lights, battery(s), speed and directional controllers, brakes, safety interlocks, and steering mechanism. If the carrier is found to be in need of repair or is in any way unsafe, the matter shall be reported immediately to the user and the carrier shall not be operated until restored to safe operating condition.

7.3.4.3 If during operation the carrier becomes unsafe in any way, the matter shall be reported immediately to the user, and the carrier shall not be operated until it has been restored to safe operating condition.

7.3.4.4 Do not make repairs or adjustments unless specifically trained and authorized to do so.

7.3.4.5 Before refueling, the engine shall be stopped and allowed to cool. The operator and passengers shall leave the carrier before refueling.

7.3.4.6 Spillage of hazardous materials shall be contained immediately and addressed via appropriate hazardous materials regulations.

7.3.4.7 Do not operate a carrier with a leak in the fuel system or battery(s). Battery(s) shall be charged and serviced per manufacturer's instructions.

7.3.4.8 Do not use open flames for checking electrolyte level in storage battery(s) or liquid level in fuel tanks.

8 MAINTENANCE PRACTICES

8.1 Introduction

Carriers may become hazardous if maintenance is neglected. Maintenance facilities, trained personnel, and procedures shall be provided. Such facilities may be on or off the premises.

8.2 Maintenance Procedures

Maintenance and inspection of all carriers shall be performed in conformance with the following practices and should follow the manufacturer's recommendations.

(a) A scheduled preventive maintenance, lubrication, and inspection system shall be followed.

(b) Only trained and authorized personnel shall be permitted to maintain, repair, adjust, and inspect carriers.

(c) Before undertaking maintenance or repair, follow the manufacturer's recommendations for immobilizing the carrier.

(d) Chock wheels and support carrier, before working underneath it.

(e) Before disconnecting any part of the engine fuel system, be sure the shutoff valve, if so equipped, is closed and follow carrier manufacturer's recommended practice.

(f) Operation to check performance of the carrier shall be conducted in an authorized area where suitable conditions exist, free of vehicular and pedestrian traffic.

(g) Before returning carrier to service, follow the manufacturer's instructions and recommended procedures.

(h) Avoid fire hazards and have fire protection equipment present in the work area. Do not use an open flame to check level or leakage of fuel, battery electrolyte, or coolant.

(i) Properly ventilate the work area in accordance with applicable regulations or local ordinance.

(j) Handle fuel cylinders with care. Physical damage, such as dents, scrapes, or gouges, may dangerously weaken the tank and make it unsafe for use.

(k) Brakes, steering mechanisms, speed and directional control mechanisms, warning devices, lights, governors, guards, and safety devices shall be inspected regularly and maintained in accordance with manufacturer's recommendations.

(l) Carriers or devices designed and approved for hazardous area operation shall be inspected to ensure that maintenance preserves the original approved safe operating features.

(m) Fuel systems shall be checked for leaks and condition of parts. If a leak is found, action shall be taken to prevent the use of the carrier until the cause of the leak has been repaired.

(n) The carrier manufacturer's capacity, operation, and maintenance instruction plated, tags, or decals shall be maintained in legible condition.

(o) Batteries, motors, speed and directional controllers, limit-switches, protective-devices, electrical conductors/insulators, and connections shall be inspected and maintained per carrier manufacturer's recommendation.

(p) Carriers shall be kept clean to minimize hazards and facilitate detection of components needing service

(q) Modifications and additions which affect capacity and safe carrier operation shall not be performed without manufacturer's prior written authorization; where authorized modifications have been made, the user shall ensure that capacity, operation, warning, and maintenance instruction plates, tags, or safety labels are changed accordingly.

(r) Care shall be taken to ensure that all replacement parts are interchangeable with the original parts and of a quality at least equal to that provided in the original equipment.

(s) Disconnect batteries, negative connection(s) first. When reconnecting, connect positive connection first.

(t) Hydraulic systems, if so equipped, shall be checked for leaks, for condition of parts. Keep body and hands away from pin-holes or nozzles that eject fluids under high pressure. Use paper or cardboard, not hands, to check for leaks.

OPERATING INSTRUCTIONS

INITIAL CHECKLIST

Use the following checklist to inspect and prep your vehicle prior to initial use.

- Check for evidence of leaking fluids, i.e. brake fluid, battery acid, or gear oil.
- Check condition of tires and tire air pressure. Maximum 90 psi Cold; 60 psi recommended. (Pneumatic tires only).
- Check to ensure wheel lug nuts are tight.
- Check that all battery connections are tight.
- Check for smooth operation of controls, switches, and brakes.
- Charge batteries.

IDENTIFICATION



FIGURE 1

The product model number, serial number, and year of manufacture is located on a silver label as shown in Figure 1, either on the front of the vehicle near the switches, on the underside of the plate where the seat is mounted, or inside the motor compartment attached to a side panel.

Whenever you correspond with Wesley International regarding your vehicle, be sure to include this information.

CHARGING BATTERIES

Our Pack Mule electric vehicles come standard with an onboard charger. They also come available with a slide out battery system, in which case, no onboard charger is included. If your unit comes with the onboard charger, place the vehicle in a well-ventilated area and follow these steps to charge the battery:

1. Position the vehicle within reach of an electrical outlet.
2. Check all battery cells for proper acid level. Fluid should be above plates.
3. Plug in the charger AC line cord (Figure 2) which is already attached to the charger into a wall plug.

CAUTION: Extension cords must be a 3-wire cord no longer than 30m (100') at 10AWG or 7.5m (25') at 16 AWG per UL guidelines. Only connect ONE charger to a single 15A circuit or the circuit may become overloaded.



FIGURE 2

VEHICLE CONTROLS, METERS, SWITCHES

The controls, meters and switches consist of:

- Key Switch, Perma-Key Switch, or On/Off Switch
- FWD/REV Directional Selector Switch
- Battery Discharge Indicator (BDI)
- Headlight / Tail Light Switch (Optional)
- Parking Brake
- Speed Control Pedal
- Brake Pedal
- Horn Button
- Foot Presence Switch (Optional)

Key Switch: For vehicles equipped with a key switch (Figure 3), the vehicle only operates when the key is in the switch. It has two positions – run and off.



FIGURE 3

Perma-Key Switch (Optional): An optional Perma-Key switch is available to replace the standard key switch. It works the same way but eliminates the need for a separate key that may get lost. It has two positions – run and off.

On/Off Rocker Switch (Optional): An optional 2 position on/off Rocker switch is available to replace the standard key switch. (Figure 4).

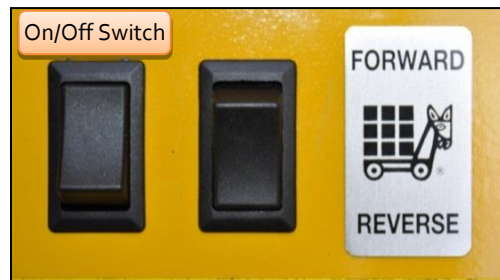

FIGURE 4

OPERATING INSTRUCTIONS

WARNING

To prevent unexpected vehicle movement or unauthorized use, always turn the key switch to the OFF position and remove the key when the vehicle is not in use

Programmable Security Switch (Optional): SAFE-T-LOCK™ is a programmable code switch, shown in Figure 5, which prevents unauthorized use of the vehicle. It is offered as an option, part number EV-E901. The SAFE-T-LOCK switch is installed in lieu of the standard switch to control access and operation of the vehicle within the customer's premises. It can be pre-installed at time of order, or purchased separately to upgrade existing vehicles.



FIGURE 5

The STL1000 switch allows plant and facility managers to input up to 99 different users/drivers to track vehicle usage. If an accident occurs, or the vehicle is damaged, the manager can easily identify the last operator. The switch also features an internal clock that records "on" hours and notifies the operator when the 250-hour mark is reached.

Each user can select a four- to eight-digit personal access code and a separate supervisor user menu programs the unit. The switch will provide the last user ID code when prompted by the supervisor. In operation, only users with active ID codes can operate the vehicle, virtually eliminating all unauthorized use, the company said.

The switch operates in a voltage range from 9 to 120 volts DC and is enclosed in an IP65 rated housing. Two internal LEDs indicate operational status - red indicates an error or lock mode and green indicates key press or touch is active. The unit also provides user feedback with key beep and error tones.

Step-by-Step Programming Instructions:

1 – Log onto the Supervisor Mode. Press 0 0 1 2 3 4 ENTER. Red and Green LED flashes along with an up tone beep indicate you are in the Supervisor Mode and ready to enter a Supervisor Mode menu.

Note: As you enter each Supervisor Mode menu, the number of Red LED flashes will correspond to the menu number. For example, one Red LED flash for menu 1, two Red LED flashes for menu 2, etc.

Before changing the Supervisor PIN, you are first going to add User locations. For this example you will check on and add User location 01 as well as more User locations as required. To do this you must go into the Add / Delete User Menu.

2 – Go into Add / Delete User Menu. Press 2 ENTER. There will be a beep along with two Red LED flashes indicating you are in Menu 2. Press 0 1 ENTER. If there is a Red flash and a low beep, it indicates that user location 01 has already been assigned. To remove location 01, press ENTER again. This will delete the location from use.

Add location 01. Press 0 1 ENTER. You should now get a Green flash along with an up tone beep indicating the location is ready to be added or assigned to a user. Press ENTER. You will get a Green LED flash along with a beep. The user location has been added.

At this point you can, in the same way, check on and add more user locations.

Before leaving Menu 2, check to make sure that location 01 and any others have been added. Press 0 1 ENTER. There should be a Red LED flash along with a low tone beep indicating the location has been assigned to the user. Check any other locations you've added the same way. A Red flash along with a low tone beep means the location has been assigned. A Green flash along with an up tone beep means the location is not assigned.

3 – Go out of Menu 2. Press CE. The switch will indicate you are back in Supervisor Mode. Press CE again to go out of Supervisor Mode. (CE can be pressed several times to make sure you are completely clear and ready to enter the next mode.)

4 – Log onto the User Mode. Press 0 1 1 2 3 4 ENTER. The switch will close and the Green LED will flash at a slow rate.

5 – Change User PIN. First decide on a new PIN. In this example, use 5 4 3 2 1. Press 1, ENTER. (This puts you in the Change User PIN Menu.) Note that the switch will open when you go into this menu.

Note: The User has 1 minute after logging on the User Mode to use menu 1 before the menu function is locked out until the next User log on.

Press 5 4 3 2 1 ENTER, again press 5 4 3 2 1 ENTER. The switch will indicate that the new PIN has been accepted.

6 – Use the new PIN to close the switch. Press 0 1 5 4 3 2 1 ENTER. The switch will close. Press ENTER to open the switch and go out of User Mode. (Since this is an example, you may want to set the PIN for User location 01 back to the 1 2 3 4 default.)

7 – Log back onto the Supervisor Mode to change the Supervisor PIN. Press 0 0 1 2 3 4 ENTER. Press 1 ENTER to go into the Change Supervisor PIN Menu. The red LED will flash once. Now just you did in the User Mode, put the new PIN in twice and enter each time. Example: Press 5 4 3 2 1 ENTER, again 5 4 3 2 1 ENTER. The switch will give an indication that the PIN was changed.

OPERATING INSTRUCTIONS

8 – Go out of Menu 1. Press CE. Press CE again to Log Off the Supervisor Mode.

9 – Check out the new Supervisor PIN. Press 0 0 5 4 3 2 1 ENTER. You should be in Supervisor Mode. You can now go to any menu by pressing the menu number and ENTER. Remember: This is an example. You should change your Supervisor PIN to one known only to you.

10 – Determine Last user. While in Supervisor Mode press 3 ENTER. This places you in the Last User Menu as indicated by three red LED flashes. Press ENTER again. The LED flashes will indicate the last user. The Green LED is for the 10's digit. The Red LED is for the 1's digit. Example 1: A single Red LED flash indicates User 01 last operated the vehicle. Example 2: Two Green flashes and three Red flashes would indicate User 23 last operated the vehicle. Press CE to leave the menu.

11 – Enable or Disable Maintenance Alarm. Press 4 ENTER. There will be four red LED flashes. Press ENTER again. If the Green LED flashes, the alarm is enabled. Press ENTER again and the Red LED will flash showing the alarm to be disabled. Press ENTER again and the Green LED will flash showing the alarm to be again enabled.

12 – Listen to the maintenance alarm. While in Menu 4 press 1 ENTER. The maintenance alarm will sound. Press CE to leave the menu. Press CE again to Log Off the Supervisor Mode.

Note: If the switch is left unattended in Supervisor mode, it will automatically exit the mode after approximately one minute.

13 – If you are unable to get into the Supervisor mode after trying either the default PIN or a newly assigned PIN, go back to Step 1 and reset the switch.

If all else fails or if you have questions about programming or installing the SAFE-T-LOCK, call Tech Support at 1-800-241-2869.

Directional Switch: The directional rocker or toggle switch is used to place the vehicle in one of three operating modes – forward, reverse, or neutral. (Figure 6) shows a rocker directional switch.

NOTE The directional switch MUST be in NEUTRAL (center) position BEFORE selecting vehicle “ON” or a “Static Return to Off” (SRO) error code will be generated by the motor controller. The vehicle is temporarily immobilized as a standard safety feature. (If your vehicle is equipped with the *Optional Foot Presence Switch and the unit is already turned on and in neutral position, the foot presence switch MUST be engaged before the directional switch is placed in forward or reverse mode, or the same error code will be displayed and the vehicle temporarily immobilized.*) If this error code is displayed, the operator simply needs to turn the directional switch back to neutral, ensure the foot presence switch is

engaged, and then switch the directional Switch to the desired forward or reverse position and the vehicle will operate.

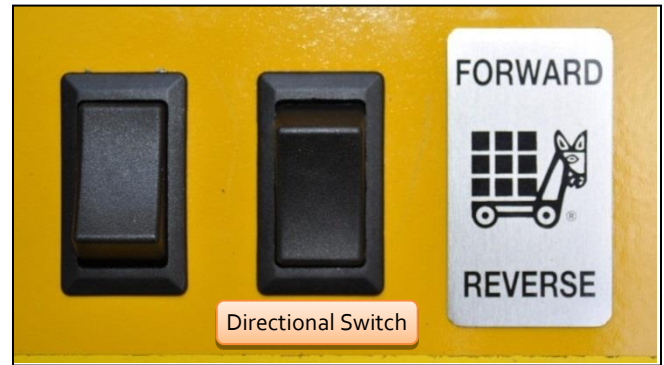

FIGURE 6

! WARNING

To prevent unexpected vehicle movement when the vehicle is next driven, always place the directional switch in the NEUTRAL position when leaving the vehicle.

Battery Discharge Indicator (BDI): The battery discharge indicator, (Figure 7), communicates directly with the onboard controller and provides information on various system parameters, such as battery state-of-charge, operating hours (on some models), or maintenance status including error codes.



FIGURE 7

When powering on the vehicle, the BDI first indicates the hours (Note: The controller is programmed to indicated traction hours, which is the time that the motor is engaged and the vehicle is moving. The controller can be programmed to display “key-on” hours which records time that the key switch is in the on position, regardless of whether it is moving or not). It then cycles through to the state of battery charge, measured in percent charge remaining. If there are any faults recorded by the controller, the BDI will display an error code and the LED by the tool wrench symbol will illuminate.

OPERATING INSTRUCTIONS

Headlight / Tail-Light and Switch (Optional): Some vehicles may include the headlight and/or tail-light (Figure 8) option. In which case, there will also be a rocker switch to turn the lights on or off. (Figure 9).



FIGURE 8



FIGURE 9

Parking Brake : This vehicle is equipped with an automatic parking brake. The brake is spring loaded to automatically apply when the accelerator pedal is released. If the unit is parked on a grade, the steering should be turned to one side to protect against brake malfunction.

Combination Accelerator/Brake Pedal:

To Accelerate: Depress the accelerator (Figure 10) with the right foot. The speed of the vehicle will be proportional to the amount that the accelerator pedal is depressed. The controller (EV-E189) regulates the speed, acting as an automatic transmission. *(If vehicle is equipped with the optional Foot Presence Switch it must be depressed simultaneously with the combination pedal to enable the vehicle to move).*

To Stop: To stop the vehicle, simply remove foot from the accelerator pedal. The regenerative brake automatically engages upon release of the accelerator. Additional mechanical braking is available by simply pushing down on the rear of the accelerator pedal with the heel of the right foot. *(The amount of programmable regenerative braking can be adjusted by following the appropriate maintenance procedures in the maintenance section of this manual).*



FIGURE 10

OPERATING INSTRUCTIONS

Horn and Horn button: The horn button is located at the top of the left side of the instrument panel. It is operated by the left hand. The horn (Figure 11) will not sound when the key or on/off switch is in the off position.



FIGURE 11

Back-Up Alarm (Optional): Optionally, a back-up may be installed on the vehicle.. The back-up alarm (Figure 12) only sounds when the directional switch is placed in the reverse position. .

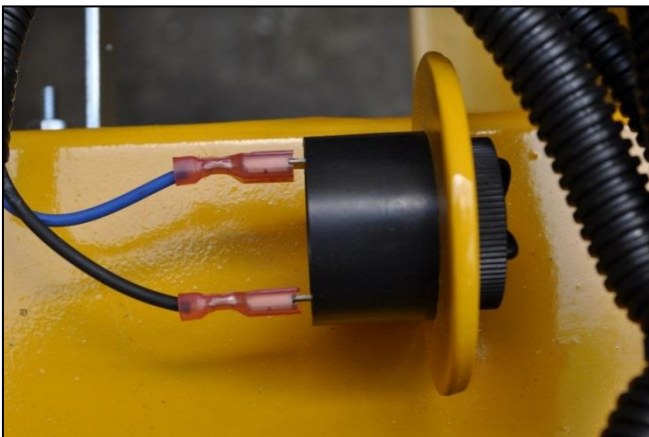

FIGURE 12

OPERATING INSTRUCTIONS

DRIVING

Follow these steps to operate your Pack Mule vehicle:

- 1) **Disconnect the battery charger.**
Remove the battery charger cord from the power outlet. **Perform Startup Checklist for Industrial Trucks** (see next page for checklist).
- 2) **Ensure surrounding area is clear of all obstructions and everything properly stored and secured.**
- 3) **Make sure you are standing on the operator platform, holding the steering wheel.**
- 4) **Confirm that the directional switch is in the neutral position and the accelerator pedal is not depressed.**
- 5) **Turn the key or on/off switch to the ON position.**
Insert the key into the ignition switch (if a key switch) located on the instrument panel. Turn the key completely to the right to the ON position, or push the rocker or toggle switch to the ON position. The indicator light on the BDI should come on. If not, do not attempt to operate the vehicle.
(If using the optional programmable security switch, follow the operating instructions detailed on Page 13)
- 6) **Move the directional switch to the desired setting.**
Push the rocker or toggle directional switch to either the forward or reverse position.
- 7) **Press the Combination Accelerator/Brake Pedal**
Depress the speed control pedal with your foot in a controlled manner. The speed of the vehicle will be proportional to the amount of pressure applied to the pedal. The controller converts the signal from the accelerator pedal, regulating the speed, acting as an automatic transmission. *(If vehicle is equipped with the optional Foot Presence Switch it must be depressed simultaneously with the combination pedal to enable the vehicle to move).*

NOTE

- If the directional switch remains in the FORWARD or REVERSE position for more than 10 seconds without depressing the speed control pedal, the safety delay feature engages, and the vehicle will not move. The operator must place the directional switch to neutral, and then select the desired direction to resume motion.
- 8) **Stop**
This unit has a combination accelerator brake pedal. Releasing the pedal activates the regenerative braking. Pressing the heel of your foot down on the back part of the pedal simultaneously engages the mechanical brake

WARNING

COASTING

To prevent injury or death resulting from coasting at above recommended speeds, limit speed with service brake.

On steep ramps or hills, it is possible for the vehicle to coast at faster than normal speeds that may be encountered on a flat surface. To prevent loss of vehicle control, speeds should be limited to no more than the maximum speed on level ground. Limit speed by activating the mechanical brake by pressing the heel of your foot on the back part of the combination accelerator/brake pedal.

LOADING/UNLOADING

Make sure the vehicle has come to a full stop before embarking/disembarking or before loading/unloading any cargo. Turn off the vehicle when loading/unloading cargo. Do not exceed the load capacity of the vehicle. The maximum load capacity includes the combined weight of the driver and cargo. Make sure the cargo is balanced and securely loaded. Do not load cargo that can easily fall off the vehicle, especially through turns. Be very careful when handling cargo that is longer or wider than the vehicle. Do not stack cargo so that the driver's view is obstructed. This vehicle is not designed to carry passengers.

PARKING

Place the directional switch in the PARK/NEUTRAL position. Turn the key switch to the OFF position. If parking on an incline, block the wheels to prevent the vehicle from rolling forward or backward.

TOWING

Attach a suitable hitch to match the trailer being towed. Wesley International offers a variety of hitches to choose from so you can find one suitable for your application. Make sure the hitch is properly installed and secured. Attach the trailer to the hitch and the trailer safety chains to the provided safety chain holes. Do not exceed the specified towing capacity of the vehicle. The maximum tow capacity includes the combined weight of the trailers, the cargo on the trailers, and the weight of the driver and cargo on the vehicle. Do not exceed 5 mph / 8 kph when towing.

START UP CHECKLIST FOR INDUSTRIAL TRUCKS

All industrial trucks that are used within <<Company>> are required to be inspected each day prior to use.

TRUCK NO. _____ OPERATOR _____ DATE _____

VISUAL	OK	FIX	COMMENTS
Obvious damage			<hr style="border: 1px solid black;"/> <hr style="border: 1px solid black;"/> <hr style="border: 1px solid black;"/>
Cracked frame welds			
Model tag readable			
Tires (proper inflation and cut free)			
Leaks			
Charging cord unplugged			
Wire insulation undamaged			
Battery connections			
Battery water level			
Steering			
Brakes			
Horn (switch must be turned on)			
Battery discharge indicator			
If leaving vehicle turn off switch			

MAINTENANCE INSTRUCTIONS

MAINTENANCE SCHEDULE

Safe trouble-free operation of your electric vehicle depends on regular and proper preventive maintenance. The following chart is a guide for servicing your Pack Mule electric vehicle.

SERVICE	BI-ANNUAL 125 Hours	ANNUAL 250 Hours
Check wheels for bent rims, missing or loose lug nuts	X	X
Check brake linkage; Check brake linings and other components for wear and deterioration	X	X
Oil all moving parts that do not have fittings with an oiler or brush (SAE 30 oil)	X	X
Grease fork pivot fittings and gears with automotive grease using a grease gun	X	X
Check and tighten all loose nuts and bolts	X	X
Inspect steering, gear housing, and linkage Tighten as necessary	X	X
Check oil level in transaxle (SAE 80-90 oil)	X	X
Tighten any loose battery terminals and coat terminals with petroleum jelly	X	X
Clean batteries & terminals with ¼ cup (60 mL) baking soda to 1 ½ gal (6L) water; ensure charger is de-energized	X	X
Check electrolyte levels of all battery cells using hydrometer ¹	X	X
Change oil in transaxle (SAE 80W-90 oil; 18 oz/0.5L)		
Clean, inspect, & repack front axle and steering fork bearings with lithium based grease		X
Lubricate steering drive chain; Check for wear		X

MAINTENANCE INSTRUCTIONS



¹ In freezing temperatures recharge the batteries after adding distilled water to make sure the water mixes with the electrolyte properly. Otherwise the water may freeze and damage the batteries.

² The recommended pneumatic tire pressure is 60 psi. Over or under inflation can reduce tire life and adversely affect vehicle handling. It may also lead to sudden tire failure which can result in the driver losing control of the vehicle.

³ A hydrometer is used to determine if a battery is properly charged. It measures the specific gravity of the electrolyte (liquid) in the battery. The electrolyte is about 1.260 in specific gravity when the battery is fully charged and about 1.100 in specific gravity when the battery is fully discharged.

MAINTENANCE INSTRUCTIONS

CAUTION ROUTINE MAINTENANCE

Before performing any maintenance or repair work, isolate the batteries from the motor and electronics by opening the circuit breaker in (Figure 13). Simply push the red push button until the red side lever fully opens as shown in Figure 14. To close the circuit breaker, simply push the red side lever to its original closed position. (Figure 13)



FIGURE 13



FIGURE 14

BATTERIES

The standard batteries used on Pack Mule vehicles are 6 volt lead acid. This manual is written around the lead acid batteries. Batteries have a maximum life. Therefore, good maintenance is important to maximize the available life of the vehicle's batteries.

BATTERY SAFETY

Always observe the following warnings when working on or near batteries:

To prevent burns or battery explosion that could result in severe personal injury or death, keep all smoking materials, open flame or sparks away the batteries.

Hydrogen gas forms when charging batteries. Do NOT charge batteries without adequate ventilation. Only a 4% concentration of hydrogen gas is explosive.

Be sure the key switch or on/off switch is in the OFF position and all electrical accessories are off before starting work on the vehicle. Open the vehicle's circuit switch as shown in Figure 24 before starting work on the vehicle.

The electrolyte in a lead acid battery is an acid solution which can cause severe burns to the skin and eyes. Treat all spills to the body and eyes with extended flushing with clear water. Then contact a physician immediately.



Always wear approved safety goggles or face shield when handling or working around batteries.

Electrolyte spills will corrode the vehicle's structural frame and body if not properly treated immediately. In the event of a spill, wear proper protective clothing, gloves, and eye wear. Thoroughly clean all affected areas with a neutralizing solution of ¼ cup (60 mL) sodium bicarbonate (baking soda) dissolved in 1 ½ gallons (6 L) of water.

It is highly recommended that insulated wrenches be used when working on our electric vehicles. Alternatively, wrap wrenches with vinyl tape to prevent the possibility of a dropped wrench onto the batteries terminals, which can short the battery, which could result in an explosion and severe personal injury or death.



BATTERY CARE

- 1) Place battery into service and complete a full discharge and charge cycle. Check and add approved water only (never acid) if needed only after this first cycle is completed.
- 2) Never discharge battery beyond 80% and do not operate battery if the specific gravity is below 1.150
- 3) If above 115° F (46° C) allow battery to cool before charging or operating
- 4) During shipment or prolonged storage the electrolyte levels may fall below the separator protector. Only after a complete discharge and charge cycle, check and keep electrolyte level above separator and 1/8" (3.175mm) below vent well. Add approved water only when required and never add acid.
- 5) Keep battery top clean, dry and vent caps tightly in place.

MAINTENANCE INSTRUCTIONS

- 6) Keep open flame and metal objects away from battery top.
- 7) Use only approved chargers of correct voltage and current output.
- 8) Keep battery compartment open and well ventilated during charge.
- 9) It is recommended that water be added to batteries near the end of the charge or after taking them to charge.
- 10) Be sure to replace the vent caps after watering so electrolyte does not splash out.

ELECTROLYTE LEVELS

Charge the batteries after each days use. Clean the batteries and wire terminals. Check that the electrolyte level is correct and add water as required. It is important that the water used be pure and free of contaminants that could reduce the life of the battery by reducing the chemical reaction. The water must be distilled or purified by an efficient filtration system.

Electrolyte level should be ½" (13 mm) above the plates in each cell. This level will leave about ¼" – 3/8" (6 – 10 mm) of space between the electrolyte and the vent tube. The level of the electrolyte is important. Too low and the plates will be exposed to air, ruining them beyond repair. Too high and the electrolyte will be forced out of the battery due to gassing and the increased volume of the electrolyte resulting from the charging cycle.

BATTERY WATERING SYSTEM

Wesley International offers a battery watering system, (Figure 15), as an option on all its vehicles. This system is a fast, accurate, and safe means of maintaining precise electrolyte levels in the batteries.

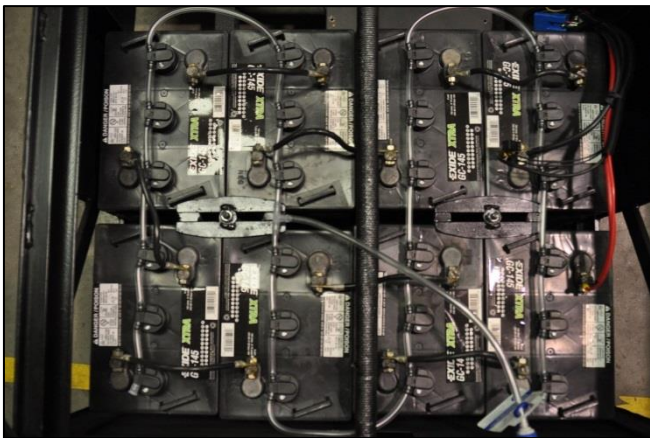

FIGURE 15

To use the watering system, simply fill the gravity feed container with a clean water source. Connect the blue connector at the end of the container flow tubing to the blue connector at the end of the battery watering system attached to the batteries. Elevate the gravity feed container at least 3 feet (1 m) to properly fill the batteries.

CLEANING BATTERIES

It is important to first neutralize any acid deposits with a solution of sodium bicarbonate (baking soda) and water. Spray the top and sides of the batteries with this solution. Use ¼ cup (60 mL) of sodium bicarbonate mixed with 1 ½ gallons (6 L) of water. Let the solution sit for at least three minutes. Rinse entire area with low pressure clear water.

BATTERY REPLACEMENT

Remove battery hold downs and cables. Lift out batteries with a safety rated lifting device.

Be sure to connect the battery terminals as shown below. Tighten the battery post hardware to 50-70 in. lbs. (6-8 Nm) torque. Protect battery terminals and battery wire terminals with a commercially available lubricant.

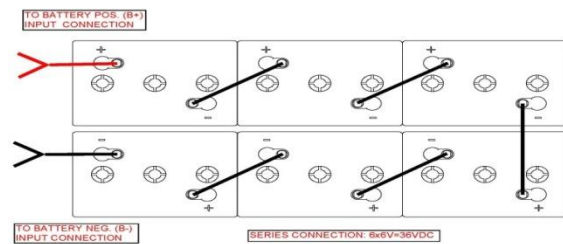

36 VOLT SYSTEM WIRING



48 VOLT SYSTEM WIRING

PROPOSITION 65 WARNING

>Battery posts, terminals and related accessories contain lead and lead compounds, chemicals known to the State of California to cause cancer and reproductive harm.

>Batteries also contain other chemicals known to the State of California to cause cancer.

>Wash hands after handling.

MAINTENANCE INSTRUCTIONS

WARNING LIFTING THE VEHICLE

To prevent possible injury or death resulting from a vehicle falling from a jack, be sure the vehicle is on a firm and level surface. Never go beneath a vehicle while it is supported by a crane or jack. Use jack stands and test the stability of the vehicle. Always place chocks in front and behind the wheels not being raised. Use extreme care when lifting due to the 3-point wheel design which is extremely unstable when lifting, especially lifting the rear.

The vehicle should only be lifted high enough to remove the front axle or rear wheels. Position jacks and jack stands only on the areas indicated (Figure 16).

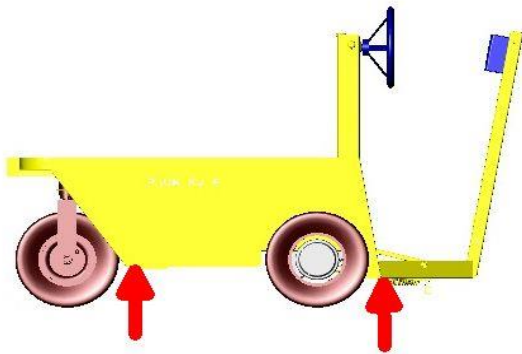

FIGURE 16

Lifting the front: To remove a front wheel or axle: First chock the front and rear of the rear tires. Loosen the front wheel hardware. Position the jack in the location indicated and carefully raise the front of the vehicle, taking care that the rear wheels do not move. Position jack stands in the locations indicated and slowly lower the vehicle to rest on the jack stands and test the stability of the vehicle.

Lifting the rear: To remove a rear wheel or axle: First raise the front of the vehicle as previously described and support on jack stands. Then position the jack in the position indicated at the rear of the vehicle. Carefully raise the rear of the vehicle with the jack and place two jack stands in the positions indicated. Slowly lower the vehicle to rest on the jack stands and test the stability of the vehicle. Lower the vehicle by reversing the lifting sequence.

LUBRICATION

Proper lubrication will ensure maximum years of trouble free service from your Pack Mule.

Illustration of vehicle's lubrication points

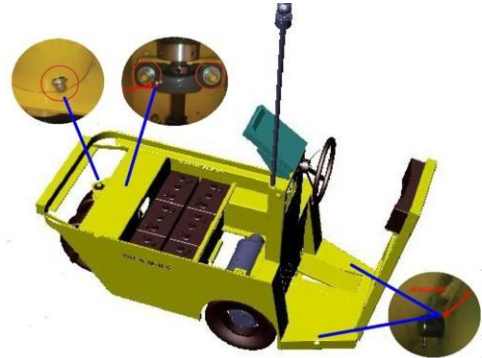

FIGURE 17

Front Fork and Steering: Lubricate wheel bearings and fork pivot and steering bearing (Figure 18), per the recommended maintenance schedule.

Lubricate the Combination Accelerator Brake Pedal pivots (Figure 17) using SAE-30 oil per the recommended maintenance schedule.

MAINTENANCE INSTRUCTIONS

Rear Axle: Check fluid level in the rear axle per the recommended maintenance schedule. The rear axle is provided with a fluid level check/fill plug (Figure 18) located at the bottom of the differential. With the vehicle on level ground, clean the area around the check/fill plug and remove plug. The correct fluid level is just below the bottom of the threaded hole. If fluid levels are low, add as required until it starts to seep from the hole. Install the check/fill plug.



FIGURE 18

To replace the fluid, lift the vehicle per the lifting procedures. Remove the rear axle cover and drain out the fluid into a container. Clean cover mating surfaces as required with proper scraping tool. Ensure cover lip is not bent. Apply thin bead of RTV sealant and torque cover bolts 16-24 lb-ft. Add 10-14 oz. 80W-90 Hypoid gear oil through the check/fill plug hole or until fluid just starts to seep from the hole.

BRAKES

The vehicle is equipped with a pair of rear mechanical drum brakes which only engage for parking and/or emergency stopping. Service mechanical brakes per the recommended maintenance schedule. Adjustments are made by turning the connecting rod with a wrench (Figure 19). Normal braking uses the regenerative braking controlled by the Combination Accelerator/Brake Pedal. (*The amount of regenerative braking or deceleration can be adjusted within the Curtis Motor Controller. See instructions on Page 29.*)



FIGURE 19

TIRES AND WHEELS

This series is offered in two tow capacity versions: 2,000 pound (907 kg) tow capacity standard transaxle and 5,000 pound (2,268 kg) tow capacity tigger transaxle. The standard transaxle has a four bolt pattern for the wheels, whereas the tigger transaxle has a five bolt pattern.

The following tire options are offered with the SC series vehicle:

- 1) Pneumatic tires (standard)
- 2) Foam-filled tires
- 3) Solid tires (black)
- 4) Solid non-marking tires (off-white)
- 5) Soft solid tires

Pneumatic tires are tubeless tires filled with air and mounted on one piece rims. They offer the smoothest ride but do require regular maintenance to ensure proper air levels are maintained and require immediate repair should they go flat.

Foam-filled tires replace the air inside pneumatic tires with a foam compound and are mounted on one piece rims. This retains the smoother ride of pneumatic tires but eliminates the regular maintenance associated with pneumatic tires. However, if a vehicle equipped with foam-filled tires sits for extended periods of time, flat spots may form.

Solid tires are solid rubber compound mounted on a two piece rim. They eliminate the possibility of flat spots and the maintenance associated with pneumatic tires but because they are solid, they do not provide as smooth a ride as pneumatic tires. Solid non-marking tires operate in the same manner but are made of a rubber compound that prevents black marks on floors.

Soft Solid tires are a rubber wheel which has molded recesses in the tire that create a smoother ride similar to a pneumatic tire.

MAINTENANCE INSTRUCTIONS

Replacing Front Tires/Wheels: To remove and repair the front tires and/or wheels, complete the following steps:

- 1) Remove the axle nut retaining clip.
- 2) Lift the front of the vehicle as explained in the “Lifting the Vehicle” Section.
- 3) Loosen the axle nuts and remove the entire wheel, hub and axle assembly from front fork.
- 4) Remove the lug nuts and remove the wheel from the axle assembly.
- 5) Reinstall the repaired or replacement tire by reversing the above sequence. Tighten to 70 to 80 ft. lbs. (95 to 108 Nm) torque.

Replacing Rear Tires/Wheels: To remove and repair the rear tires and/or wheels, complete the following steps:

- 1) Loosen the lug nuts on the wheel.
- 2) Lift the rear of the vehicle as explained in the “Lifting the Vehicle” Section.
- 3) Remove the lug nuts and remove the wheel from the transaxle.
- 4) Reinstall the repaired or replacement tire by reversing the above sequence. Tighten to 70 to 80 ft. lbs. (95 to 108 Nm) torque.

COMPONENTS - ELECTRICAL

BASIC ELECTRICAL COMPONENTS

Your Pack Mule electric vehicle is purposely designed around the “Keep it Simple” principal. Our philosophy at Wesley International is to engineer products with only the critical components necessary to meet the demanding industrial environment, cutting out any unnecessary “bells and whistles” which only increase ownership costs. The following core components make up the electrical portion of the vehicle:

- 1) Onboard Battery Charger
- 2) Batteries (*shown on page 21*)
- 3) Motor
- 4) Controller
- 5) Battery Discharge Indicator (BDI) (*shown on page 34*)
- 6) Throttle Position Device
- 7) Solenoid
- 8) Circuit Breaker

This section will cover each of these core components (except batteries which is covered in the Maintenance section), including troubleshooting.

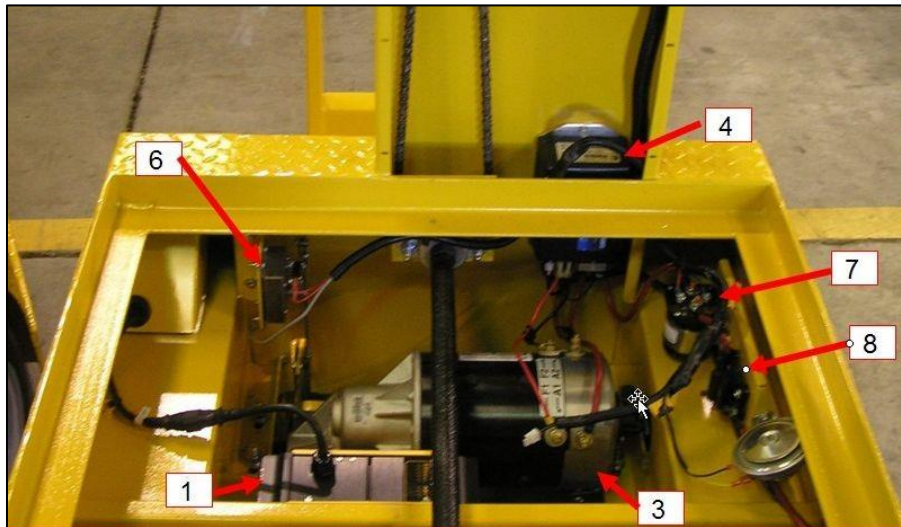

COMPONENTS - ELECTRICAL

ONBOARD BATTERY CHARGER

This section assumes your unit has the standard onboard Delta-Q Battery Charger (Figure 20).



FIGURE 20

If your vehicle has a previous model charger, please refer to the support section of our website at www.packmule.com for the applicable user's guide.

The onboard charger is air cooled, eliminating any moving parts for increased reliability and life span. Because of this, the mounting location has been designed to optimize air flow and it is important that this air flow is not inhibited in any way. Regularly check the cooling fins to ensure they are free of dirt, dust, or other contaminants.

The charger is an IP66 (NEMA4) enclosure and is designed for an operating temperature of -30°C to +50° C (-22° F to 122° F). It accepts AC input voltage range of 85 – 265 VAC with a nominal input voltage of 120 VAC or 230 VAC rms. The input frequency range is 45 – 65 Hz with a maximum input current of 12A and a nominal input current of 9.5A rms at 120 VAC or 5A rms at 230 VAC.

The charger includes an easy to read 10-LED display as follows:

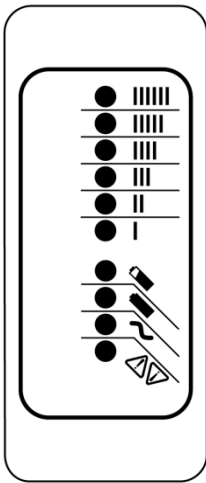



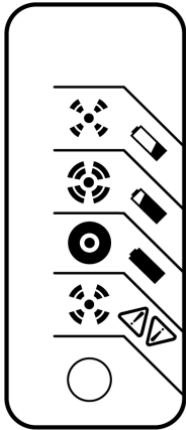

LED Color	Indication (following "Power-On Self Test")	
Ammeter (Amber)		Solid: Displays approximate scale of current output during bulk phase.
		Flashing: High internal charger temperature. Output reduced.
80% Charge (Amber)		Solid: Bulk charge phase complete, 80% charged. In Absorption phase.
		Flashing: With no battery connected, indicates algorithm # selected by number of flashes.
100% Charge (Green)		Solid: Charging complete. Charger in Maintenance Mode.
		Flashing: Absorption phase complete. In Finish phase
AC On (Amber)		Solid: AC power good.
		Flashing: Low AC voltage. Check voltage and extension cord length.
Fault (Red)		Flashing: Charger error. Reset charger power and refer to trouble shooting instructions.

COMPONENTS - ELECTRICAL







The optional charger Single-LED display, if included, would be located on the front panel, near the key-switch.



LED Color	Indication (following "Power-On Self Test")	
Green		Solid: Charging complete. Charger in Maintenance Mode.
		Flashing: Short: <80% Charge Long: >80% Charge
Amber		Solid: Reduced power mode: Low AC voltage or High internal charger temperature.
		Flashing: Charger error. Reset charger power and refer to trouble shooting instructions.

- 1) Do not expose charger to oil, mud or direct heavy water spray when cleaning vehicle.
- 2) If the detachable input power supply cord set is damaged, replace with a cord that is:
 - a. For North America – UL or CSA listed/approved detachable cord, 3 conductor, 16AWG minimum, and rated SJT; terminating in a grounding type IEC 60320 C14 plug rated 250V, 13A minimum; or
 - b. For all other countries – a safety approved detachable cord, 3 conductor, 1.5mm² minimum, rated appropriately for industrial use. The cord set must terminate on one end with a grounding type input connector appropriate for use in the country of destination and, on the other end, an output grounding type IEC 60320 C14 plug.
- 3) The enclosure of the charger has been tested successfully to EN60529, meeting IP66. The AC supply inlet is rated to IP20, which is suitable for indoor use only. Keep all AC connections clean and dry.

If a fault occurs, count the number of red flashes between pauses and refer to the following table:

Red Flashes	Cause	Solution
	Battery High Voltage	Check battery size and condition and reset charger (interrupt AC power for 15 seconds).
	Battery High Voltage	Check battery size and condition and reset charger (interrupt AC power for 15 seconds).
	Charge Timeout caused by battery pack not reaching required voltage. Charger output was reduced due to high temperatures.	Check connections. Operate charger at a lower ambient temperature.
	Check Battery: Battery could not be trickle charged up to minimum voltage	Check for shorted or damaged cells.
	Over-Temperature: Charger shut down due to high internal temperature.	Ensure sufficient cooling air flow and reset charger (interrupt AC power for 15 seconds).
	Charger Internal Fault	Reset charger (interrupt AC power for 15 seconds). If fault persists, likely needs to be replaced.

COMPONENTS - ELECTRICAL

MOTOR

All Pack mule electric vehicles are equipped with Advanced Motor and Drives “DL” Series Separately Excited DC motors (Figure 21). The motor Field and Armature are completely separate and are energized independently by the motor controller.



FIGURE 21

CONTROLLER

The PC Series electric vehicle is equipped with a Curtis separately excited (Sep Ex) motor speed controller (Figure 22). These programmable controllers are simple to install, efficient, and cost effective. The Curtis controller provides smooth precise control of motor speed and torque. A full-bridge field control stage is combined with a half-bridge armature power stage to provide solid state motor reversing and full regenerative braking without additional relays or contactors.

The controller's rugged IP53 housing and packaging are built to with-stand shock and vibration. The controller is fully programmable through the Curtis 13XX handheld programmer. In addition to configuration flexibility, the programmer provides diagnostic and test capability. The Curtis motor controller offers superior operator control of the vehicle's motor drive speed.

Features include:

- Interlock braking with load sensor to meet required braking distance without unnecessary harsh braking at light loads
- Maintenance monitor responds to preset vehicle operating hours and drive hours as programmed by the OEM
- Two hour meters—total KSI-on hours and traction hours—and the associated maintenance timers are built into the controller
- BDI calculations performed within controller
- Estimates motor temperature based on field resistance and cuts back maximum speed if the motor is overheated
- Diagnostic checks for field open and field shorted faults

- Supports PWM electromagnetic brake with maximum continuous current of 2 amps
- Supports Type 4 throttle
- Active pre-charge of controller capacitor bank extends life of main contactor
- Compatibility with Curtis 1307/1311 handheld programmers for quick and easy testing, diagnostics, and parameter adjustment
- Continuous armature current control, reducing arcing and brush wear
- Complete diagnostics through the handheld programmer, the built-in Status LED, and the optional 840 Spyglass display
- Two fault outputs provide diagnostics to remotely mounted displays
- Regenerative braking allows shorter stopping distances, increases battery charge, and reduces motor heating
- Automatic braking when throttle is reduced provides a compression braking feel and enhances safety
- Brake/Drive Interlock meets ISO stopping distance requirements
- Ramp restraint feature provides automatic electronic braking that restricts vehicle movement while in neutral
- Meets EEC fault detect requirements
- Linear cutback of motor drive current during over-temperature or under-voltage
- Linear cutback of regenerative braking current during overvoltage
- High pedal disable (HPD) and static return to off (SRO) interlocks prevent vehicle runaway at startup
- Internal and external watchdog circuits ensure proper software operation
- Fully protected inputs and short-circuit protected output drivers



FIGURE 22

This manual covers the most commonly required information as it pertains to the Pack Mule vehicles. For more detailed instructions, contact Wesley International for a copy of the complete manual for the Curtis motor controller, or download a copy from www.packmule.com.

COMPONENTS - ELECTRICAL

Your Pack Mule vehicle should be equipped with one of the following Curtis motor controller models:

24 Volt DC:	Curtis Model 1243
36 Volt DC:	Curtis Model 1243 or 1268
48 Volt DC:	Curtis Model 1268
36 Volt AC:	Curtis Model 1234
48 Volt AC:	Curtis Model 1234

If your vehicle is equipped with an older Sevcon motor controller, please contact Wesley International for a copy of the Sevcon controller manual, or download a copy from www.packmule.com. Upgrade kits are available from Wesley for those who wish to upgrade an older vehicle equipped with a Sevcon controller to a Curtis controller platform. Contact Wesley's parts department for more information.

Programmable Parameters: All Pack Mule vehicles leave the factory with standard default parameters programmed in the controller, unless specific parameter settings are requested at the time of order. These parameters can be reprogrammed in the field using a Curtis handheld programmer, available from Wesley. Generally, there are five parameters which owners may want to modify to suit their specific safety or user preferences as follows:

- a) Acceleration Rate
- b) Braking Rate
- c) Deceleration Rate
- d) Maximum Forward Speed
- e) Maximum Reverse Speed

Acceleration Rate: The acceleration rate defines the time it takes the controller to accelerate from 0% drive output to 100% drive output. A larger value represents a longer acceleration time and a gentler start. Fast starts can be achieved by reducing the acceleration time, i.e., by adjusting the accel rate to a smaller value. The acceleration rate is adjustable from 0.1 to 3.0 seconds. The default setting for this is 1.6.

Braking Rate: The braking rate defines the time it takes the controller to increase from 0% braking output to 100% braking output (as defined by the corresponding mode-specific brake current limit) when a new direction is selected. A larger value represents a longer time and consequently gentler braking. Faster braking is achieved by adjusting the braking rate to a smaller value. The braking rate is adjustable from 0.1 second to 3.0 seconds. The default setting for this is 0.1

Deceleration Rate: The deceleration rate defines the time it takes the controller to reduce its output to the new throttle request when the throttle is reduced or released. A lower value represents a faster deceleration and thus a shorter stopping distance. The decel rate defines the vehicle's

Braking characteristic for any reduction in throttle, including to neutral, that does not include a request for the opposite direction. The decel rate is adjustable from 0.1 to 10.0 seconds. The default setting for this is 2.5.

Maximum Forward Speed: The maximum forward speed parameter defines the maximum controller voltage output at full throttle, in the forward direction. The maximum forward speed parameter is adjustable from the programmed creep speed up to 100%. The default setting for this is 70, which equates to about 7 mph (12.9 kph).

Maximum Reverse Speed: The maximum reverse speed parameter defines the maximum controller voltage output at full throttle, in the reverse direction. The maximum reverse speed parameter is adjustable from 0% to 100%. The default setting for this is 35 or about 1/2 the forward speed.

Controller Maintenance: There are no user serviceable parts in the Curtis controller. No attempt should be made to open, repair, or otherwise modify the controller. Doing so may damage the controller and will void the warranty. It is recommended that the controller be kept clean and dry and that its fault history file be checked and cleared periodically.

Periodically cleaning the controller exterior will help protect it against corrosion and possible electrical control problems created by dirt, grime, and chemicals that are part of the operating environment and that normally exist in battery powered systems.

Use the following cleaning procedure for routine maintenance:

- 1) Remove power by disconnecting the battery.
- 2) Discharge the capacitors in the controller by connecting a load (such as a contactor coil or a horn) across the controller's B+ and B-terminals.
- 3) Remove any dirt or corrosion from the connector areas. The controller should be wiped clean with a moist rag. Dry it before reconnecting the battery. The controller should not be subjected to pressured water flow from either a standard hose or a power washer.
- 4) Make sure the connections are tight, but do not over-tighten them.

COMPONENTS - ELECTRICAL

Fault Codes and Troubleshooting Chart:

Table 7 TROUBLESHOOTING CHART

LED CODE	PROGRAMMER LCD DISPLAY	FAULT CATEGORY	POSSIBLE CAUSE	FAULT CLEARANCE
0,1	NO KNOWN FAULTS	0	n/a	n/a
1,1	CURRENT SHUNT FAULT	1	1. Abnormal vehicle operation causing current spikes. 2. Current sensor out of range. 3. Controller Failure.	Cycle KSI. If problem persists, replace controller.
1,2	HN FAILSAFE	1	1. Noisy environment. 2. Self-test or watchdog fault. 3. Controller failure.	Cycle KSI. If problem persists, replace controller.
1,3	M - SHORTED	1	1. Internal or external short of M- to B-. 2. Incorrect motor wiring. 3. Controller failure.	Check wiring; cycle KSI. If problem persists, replace controller
1,4	SRO	3	1. Improper sequence of KSI, interlock, and direction inputs. 2. Interlock or direction switch circuit open. 3. Sequencing delay too short. 4. Wrong SRO or throttle type selected. 5. Misadjusted throttle pot.	Follow proper sequence; adjust throttle if necessary; adjust programmable parameters if necessary.
2,1	THROTTLE WIPER HI	1	1. Throttle input wire open or shorted to B+. 2. Defective throttle pot. 3. Wrong throttle type selected.	When Throttle Wiper High input returns to valid range.
2,2	EMR REV WIRING	1	1. Emergency reverse wire or check wire open.	Re-apply emergency reverse or cycle interlock.
2,3	HPD	3	1. Improper sequence of KSI, interlock, and throttle inputs. 2. Misadjusted throttle pot. 3. Sequencing delay too short. 4. Wrong HPD or throttle type selected	Follow proper sequence; adjust throttle if necessary; adjust programmable parameters if necessary.
	SRVC TOTAL	3	1. Total maintenance timer expired.	Reset with programmer.
	SRVC TRAC	3	1. Traction maintenance timer expired	Reset with programmer.
	TOTAL DISABLED	3	1. Total disable timer expired.	Reset with programmer.
	TRAC DISABLED	3	1. Traction disable timer expired.	Reset with programmer.
2,4	THROTTLE WIPER LO	1	1. Throttle pot wire open or shorted to B+. 2. Wrong throttle type selected. 3. Defective throttle pot.	When Throttle Wiper Low input returns to valid range.
3,1	FIELD SHORT	1	1. Main contractor coil shorted. 2. Field winding shorted to B+ or B-. 3. Field resistance too low.	Check contractor coil and field winding; cycle KSI.
3,2	MAIN CONT WELDED	1	1. Main contactor stuck closed. 2. Main contactor driver shorted.	Check wiring and contactor; cycle KSI.
3,3	FIELD OPEN	1	1. Field winding connection open. 2. Field winding open.	Check wiring and cycle KSI.
3,4	MISSING CONTACTOR	1	1. Main contactor coil open. 2. Main contactor missing. 3. Wire to main contactor open.	Check wiring and cycle KSI.

COMPONENTS - ELECTRICAL

Fault Codes and Troubleshooting Chart:

Table 7 TROUBLESHOOTING CHART, cont'd

LED CODE	PROGRAMMER LCD DISPLAY	FAULT CATEGORY	POSSIBLE CAUSE	FAULT CLEARANCE
4,1	LOW BATTERY VOLTAGE	2	<ol style="list-style-type: none"> 1. Battery voltage < undervoltage cutback. 2. Corroded battery terminal. 3. Loose battery or controller terminal. 	When voltage rises above undervoltage cutoff point.
4,2	OVERVOLTAGE	2	<ol style="list-style-type: none"> 1. Battery voltage > overvoltage shutdown limit. 2. Vehicle operating with charger attached. 	When voltage falls below overvoltage cutoff point.
4,3	THERMAL CUTBACK	2	<ol style="list-style-type: none"> 1. Temperature > 85°C or < -25°C. 2. Excessive load on vehicle. 3. Improper mounting of controller. 	Clears when heatsink temperature returns to within acceptable range.
4,4	ANTI-TIEDOWN	3	<ol style="list-style-type: none"> 1. Mode switches shorted to B+. 2. Mode Select 1 "tied down" to select Mode 2 or Mode 4 permanently. 	Release Mode Select 1.
	MOTOR HOT	3	<ol style="list-style-type: none"> 1. Field resistance > motor hot setpoint. 	When resistance < setpoint.
	MOTOR WARM	3	<ol style="list-style-type: none"> 1. Field resistance > motor warm setpoint. 	When resistance < setpoint.

COMPONENTS - ELECTRICAL

BATTERY DISCHARGE INDICATOR (BDI)

The Curtis BDI (Figure 23 shows the 24/36V version) displays various system parameters, such as battery state-of-charge, operating hours or maintenance status from the Curtis motor controller.

Features include:

- Attractive, easy-to-read, 8 character dot matrix Liquid Crystal Display.
- 6 LEDs -five green to indicate battery state-of-charge and one red to indicate that a fault has occurred.
- Displays hours of use, battery state-of-charge and messages from the Curtis motor controller.
- Molded-in rear Molex style connector provides a low-cost, rugged and reliable installation.
- Front sealed (IP65) for use in harsh environments.



FIGURE 23

The BDI in 48 volt vehicles will display battery state-of-charge and operating/ Traction hours only. Figure 24:



FIGURE 24

THROTTLE POSITION DEVICE

The throttle position device (Figure 25) is a rugged assembly with IP66 throttle sensor protection for reliable use in harsh industrial environments.

There are no user serviceable parts in the throttle position device. No attempt should be made to open, repair, or otherwise modify the assembly. Doing so may damage the assembly and will void the warranty.

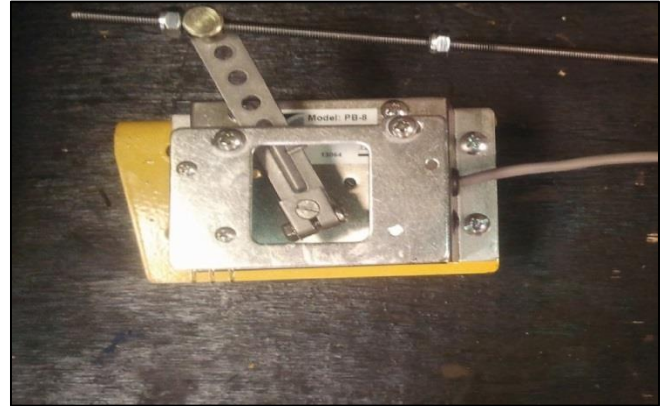

FIGURE 25

SOLENOID

The Pack Mule is provided with a SPNO DC Power Contactor. This unit is sealed and is water resistant. The coil voltage is matched to your particular vehicle operating voltage, i.e. 36V or 48V. The AC option uses 24V coil regardless of vehicle system voltage (Figure 26).



FIGURE 26

COMPONENTS – ELECTRICAL

WIRING DIAGRAM

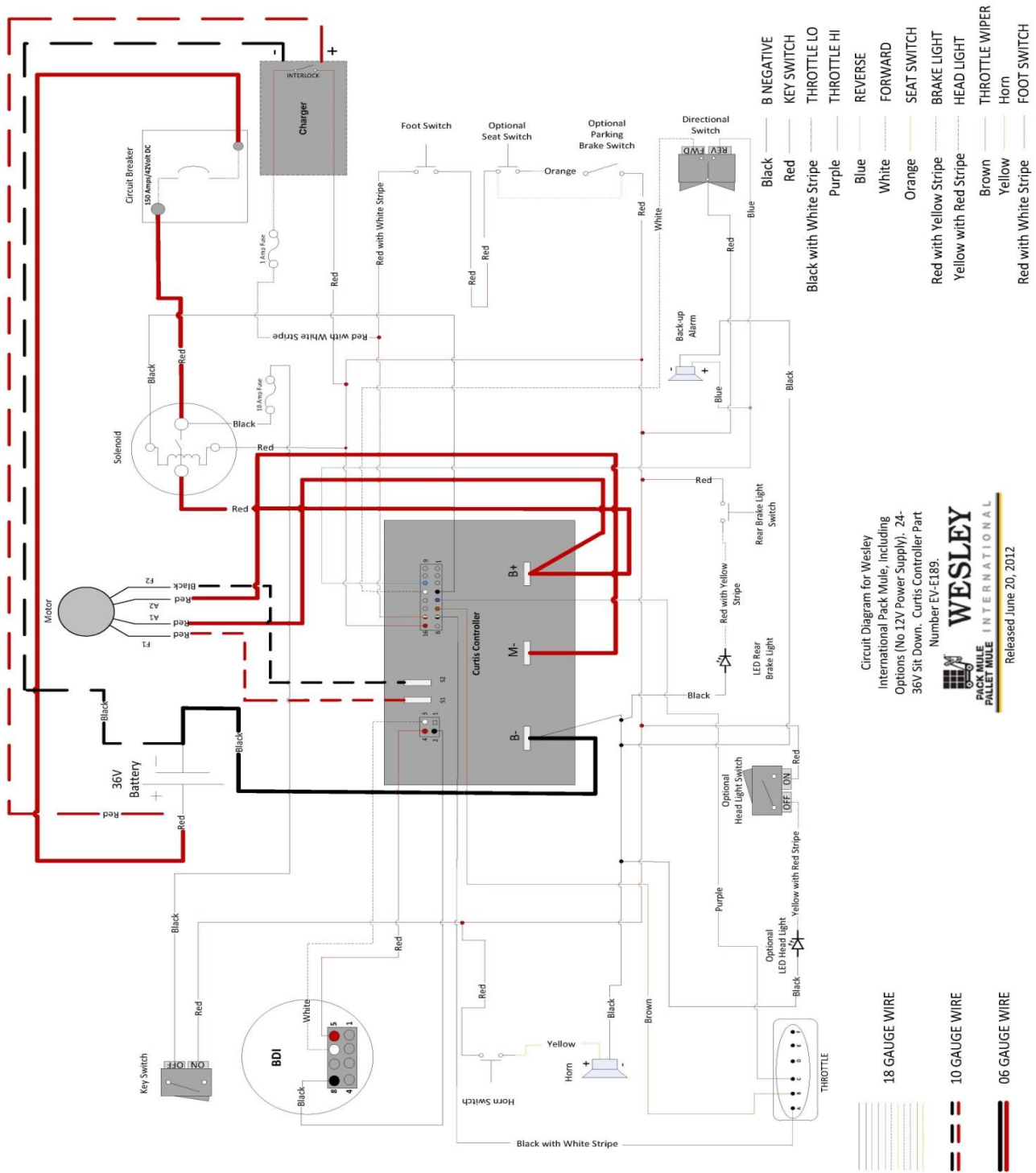

Circuit Diagram for Wesley International Pack Mule, including Options (No 12V Power Supply), 24-36V Sit Down, Curtis Controller Part Number EV-E189.

WESLEY
PACK MULE
PALLET MULE INTERNATIONAL

Released June 20, 2012

COMPONENTS - ELECTRICAL

PARTS LIST – ELECTRICAL

Part	Part Number
Key Switch, 3-position (standard)	EV-E100
Key Replacement, set of 2	EV-E160
Directional Switch, 3 position Rocker	EV-E156
Horn	EV-E130
Horn Button	EV-E041
BDI – 24 / 36 volt vehicles	EV-E241
BDI – 48 volt vehicles	EV-E241-802
Solenoid, 4-terminal 24V	EV-E014HD
Solenoid, 4-terminal 36V	EV-E064HD
Solenoid, 4-terminal 48V	EV-E204 HD
10 Amp Fuse	EV-E015
Fuse Holder	EV-E016
Charger Receptacle	EV-E027
Charger Cord	EV-E026
Onboard Battery Charger, 24 volt	EV-E801-24
Onboard Battery Charger, 36 volt	EV-E801-36
Onboard Battery Charger, 48 volt	EV-E801-48
Motor Controller, DC, 24 / 36 volt	EV-E189
Motor Controller, DC, 48 volt	EV-E189-48
Motor Controller, AC, 36 volt	EV-E181
Motor, DC	EV-D040-S
Motor, AC	EV-E185
Throttle Position Device	EV-E078
Directional Switch, 3 position Toggle	EV-E035

COMPONENTS - ELECTRICAL

PARTS LIST – AVAILABLE OPTIONS

Part	Part Number
Perma-Key Switch	EV-E194PK
On/Off Switch	EV-E017
Programmable Code Security Switch	EV-E901
Headlight/Taillight Switch, Rocker	EV-E155
Single LED Charge Status Plate	EV-E808L
Foot Presence Switch	EV-E128
Battery Watering System – 24V GC135	EV-E900-6
Battery Watering System – 24V GC145	EV-E900-7
Battery Watering System – 36V GC135	EV-E900-2
Battery Watering System – 36V GC145	EV-E900-1
Battery Watering System – 48V FS8D	EV-E900FX-310
Headlight/Taillight – 24 / 36 volt	EV-E210-S
Headlight/Taillight – 48 volt	EV-E210-48-S
Headlight/Taillight/Brake light – 24 / 36 volt	EV-E191
Headlight/Taillight/Brake light – 48 volt	EV-E191-48
Flashing Safety Beacon – Amber	EV-E183
Flashing Safety Beacon – Blue	EV-E182B
Flashing Safety Beacon – Red	EV-E182R
Back-up Alarm	EV-E159A
Proximity Alarm	EV-E149
Curtis AC/DC Program/Diagnostic Handset	EV-E180
Hitch, Spring-Loaded Clevis, 1" pin	EV-F130H
Hitch, Spring-Loaded Clevis, 5/8" pin	EV-F178H
Hitch, Pin	EV-F134P
Hitch, Pintle	EV-F092
Hitch, Eye 2-3/8"	EV-F132
Hitch, Auto Coupling	EV-F133H
Hitch, 3-Tier Assembly with Pin	EV-F134

COMPONENTS – MECHANICAL - PARTS LIST – FRONT WHEEL STEER ASSEMBLY

#	Description	Part #	Qty.
1	Dual Fork Assembly	EV-W016	1
1	Dual Fork Assembly, for SC series units (Not Shown)	EV-W016-SC	1
1	Dual Fork Assembly, for SCT series units (Not Shown)	EV-W016-SCT	1
2	Dual Front Wheel Axle, 1" X 18"	EV-W017	1
3	Sleeve	EV-W007	2
3	Sleeve, for SCT series/Wide Tire units (Not Shown)	EV-W007L	2
4	Spacer	EV-W014	2
4	Spacer, for SCT series/Wide Tire units (Not Shown)	EV-W011	2
5	1" Flat Washer	EV-W027	6
6	1" Lock Washer	EV-W026	2
7	1" Slotted Hex Nut	EV-W006	4
8	Hub with 4 Studs	EV-W001	2
8	Hub with 5 Studs	EV-W034	2
9	Race, Bearing	EV-W010	6
10	Tapered Roller Bearing	EV-W009	6
11	Bushing, 1" X 1.25" X 0.625"	EV-W011	1
12	Bushing, 1" X 1.25" X 0.5"	EV-W011-S	1
13	Seal, Oil	EV-W008	6
14	1" Thin Slotted Hex Nut	EV-W013	1
15	Pin, Cotter 3/16" – 1 1/4"	EV-W025	1
16	Lug Nuts	EV-W023	4 or 5

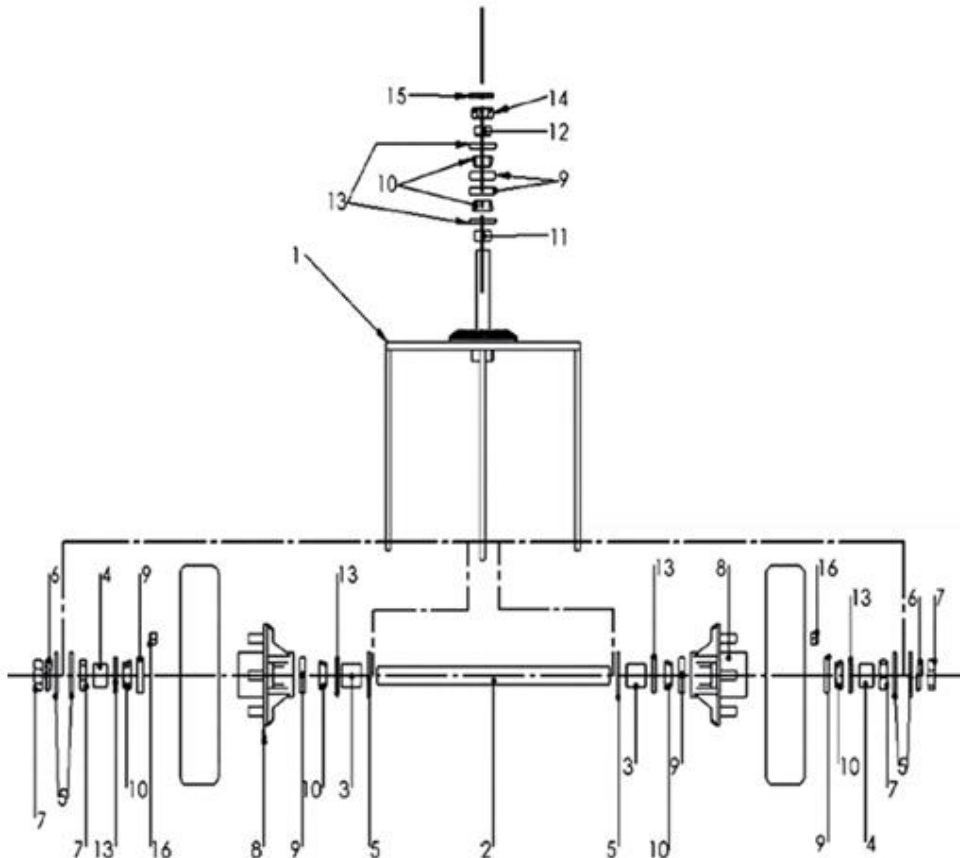

ACCELERATOR LINKAGE

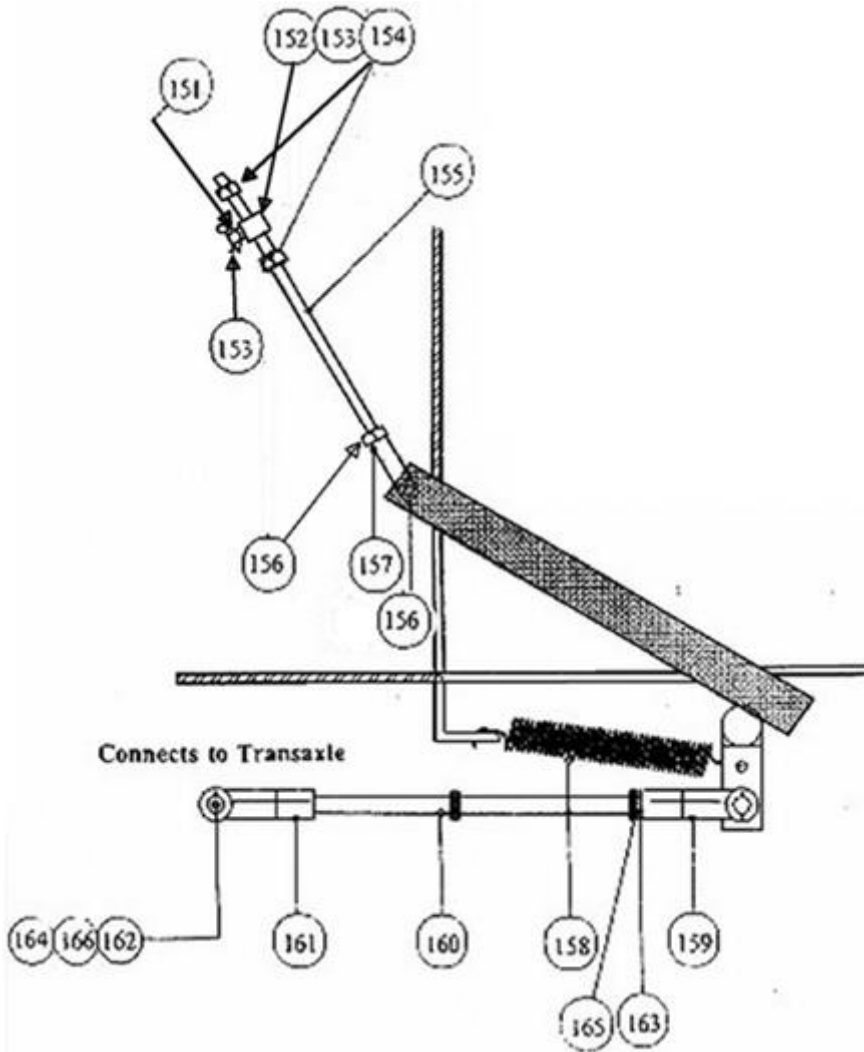

Item	Description	Part Number
151	Wave Spring	EV-G065
152	Swivel Rod	EV-G064
153	Cotter Pin, 1/8" (2)	EV-D016
154	Locknut (2)	AA-73
155	Threaded Rod	EV-G062
156	Nut, 5/16"	EV-G015
157	Ball Joint	EV-G063
158	Spring (3)	EV-D006
159	1/2 Yoke End, Left (2)	EV-D001
160	Brake Rod, 1/2" (2)	EV-D005
161	1/2 Yoke End, Left (2)	EV-D003
162	Clevis Pin, 1/2" (4)	EV-D010
163	Lockwasher, 1/2" (2)	EV-D011
164	Cotter Pin (4)	EV-D012
165	1/2" -20 Hex Nut (2)	EV-D017
166	Flat Washer 1/2" (4)	EV-D018

Transaxle Diagram for SC Series

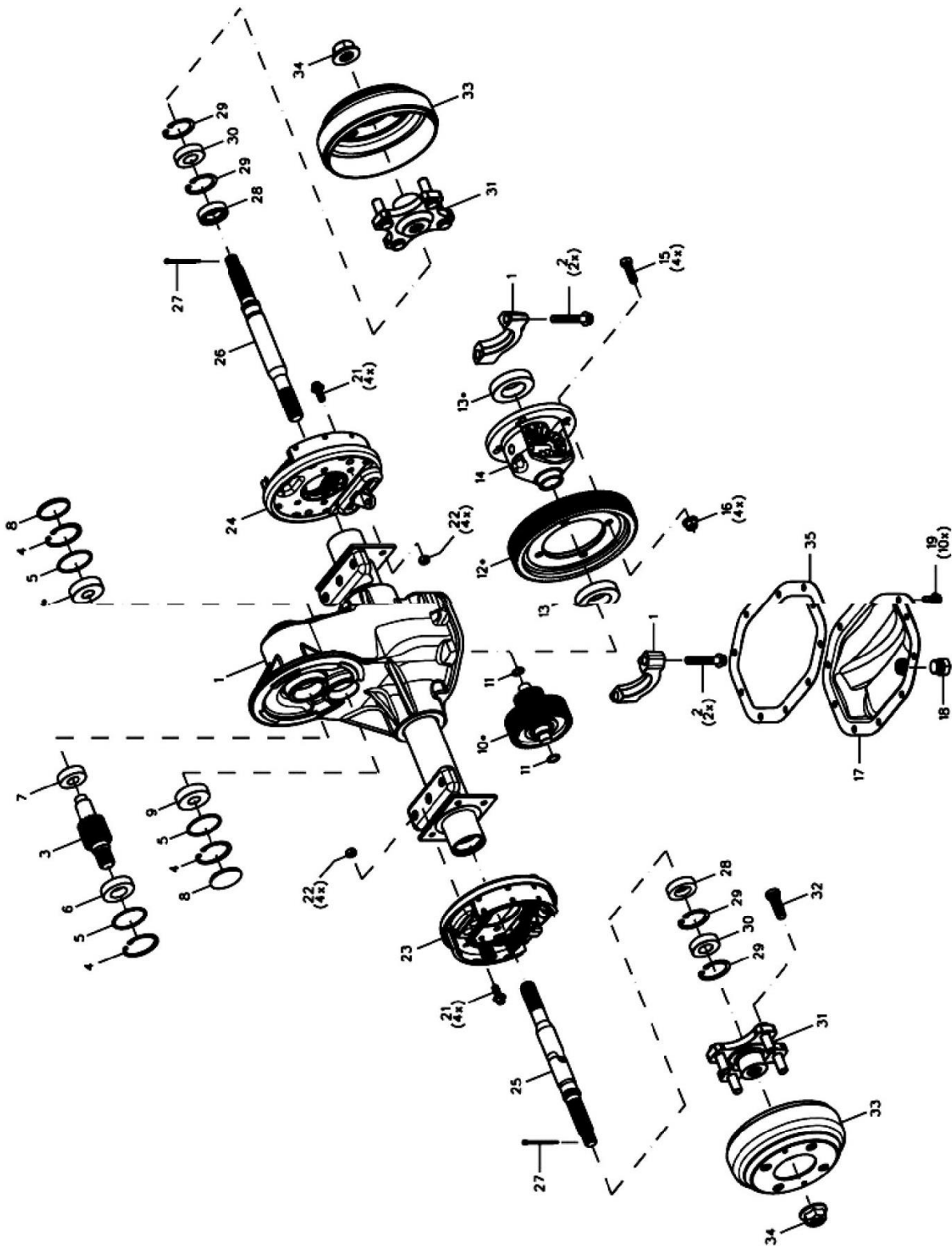

Transaxle Parts List for the SC Series

#	Part	Part Number	QTY
3	Gear, Input	See Kit	1
4	Ring, Retaining	EV-T016	3
5	O-Ring	EV-T014	3
6	Bearing, Ball	EV-T015	1
7	Bearing, Ball	EV-T013	1
8	Plug, End Cap	EV-T017	2
9	Bearing, Ball	EV-T011	2
10	Gear, Intermediate Assembly	See Kit	1
11	O-Ring	EV-T010	2
12	Gear, Final Drive	See Kit	
13	Bearing, Ball	EV-T008	2
15	Screw, Cap	EV-T006	4
16	Nut, Lock	EV-T007	4
17	Plate, Cover	EV-T018	1
18	Plug, Fill	EV-T020	1
19	Screw, Cover Plate	EV-T021	10
23	Brake Assembly, Left Hand Shoe Type	EV-T054	1
23	Brake Assembly, Left Hand Shoe Type (Stock Chaser)	EV-T054-S	1
24	Brake Assembly, Right Hand Shoe Type	EV-T055	1
24	Brake Assembly, Right Hand Shoe Type (Stock Chaser)	EV-T055-S	1
25	Shaft, Axle 29" Left Hand (15 1/4" length)	EV-T023-29	1
25	Shaft, Axle 32" Left Hand (18 1/8" length)	EV-T023-32	1
5	Shaft, Axle 36" Left Hand (23 1/4" length)	EV-T023-36	1
26	Shaft, Axle Right Hand	EV-T025	1
28	Seal, Oil	EV-T030	2
29	Ring, Retaining	EV-T029	4
30	Bearing, Ball	EV-T028	2
31, 32, 33	Hub and Drum – 4-lug assembly with studs	EV-T058	2
34	Nut, Flange Hex	EV-T064	2
Kit	Kit, Gear Set (Includes #3, #10, #12)	EV-T065	1

Transaxle Diagram for the SCT Series

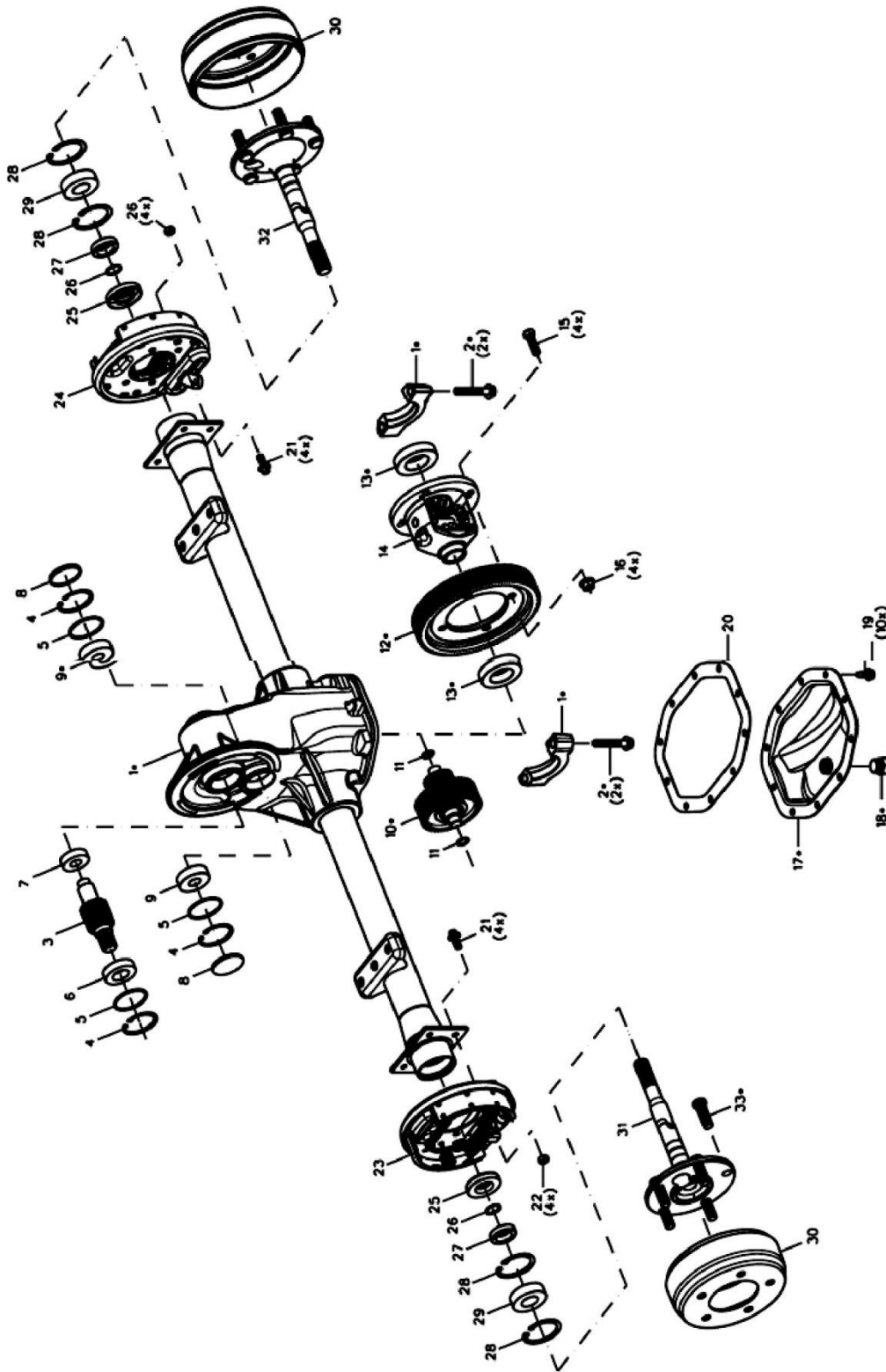

Transaxle Parts for SCT Series

#	Part	Part Number	QTY
3	Gear, Input	See Kit	1
4	Ring, Retaining	EV-T016	3
5	O-Ring	EV-T014	3
6	Bearing, Ball	EV-T015	1
7	Bearing, Ball	EV-T013	1
8	Plug, End Cap	EV-T017	2
9	Bearing, Ball	EV-T011	2
10	Gear, Intermediate Assembly	See Kit	1
11	O-Ring	EV-T010	2
12	Gear, Final Drive	See Kit	1
13	Bearing, Ball	EV-T008	2
15	Screw, Cap	EV-T006	4
16	Nut, Lock	EV-T007	4
17	Plate, Cover	EV-T018	1
18	Plug, Fill	EV-T020	1
19	Screw, Cover Plate	EV-T021	10
23	Brake Assembly, Left Hand Shoe Type	EV-T054	1
23	Brake Assembly, Left Hand Shoe Type (Stock Chaser)	EV-T054-S	1
24	Brake Assembly, Right Hand Shoe Type	EV-T055	1
24	Brake Assembly, Right Hand Shoe Type (Stock Chaser)	EV-T055-S	1
25	Seal, Oil	EV-T076	2
26	Ring, Retaining	EV-T077	2
27	Ring, Retaining, Wheel Bearing	EV-T078	2
28	Ring, Retaining	EV-T079	4
29	Bearing, Ball	EV-T080	2
30	Drum, Brake (5 lug)	EV-T075	2
31	Shaft, Left Hand Axle 32"	EV-T081-32	1
31	Shaft, Left Hand Axle 36"	EV-T081-36	1
32	Shaft, Right Hand Axle	EV-T082	1
Kit	Kit, Gear Set (Input, Intermediate Assembly, Final Drive)	EV-T083	1
37	Drum Assembly (5 lug)	EV-T075	1

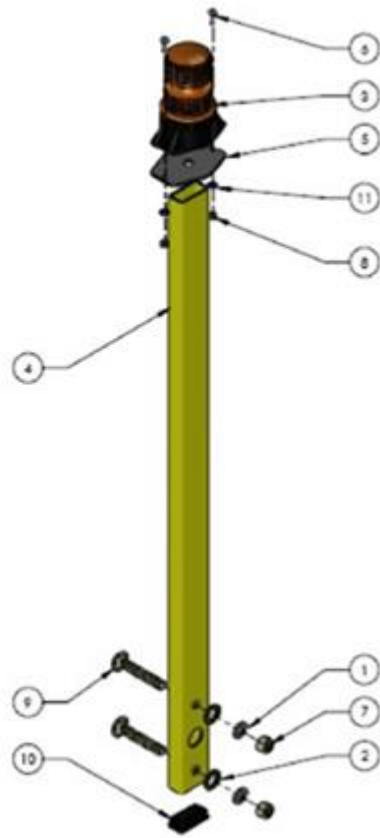

Optional Beacon

ITEM NO.	PART NUMBER	DESCRIPTION	QTY.
1	EV-D011	Washer, Split Lock, 1/2" ID	2
2	EV-D018	Washer, 1/2"ID SAE Zn	2
3	EV-E183PD	Beacon, Pedestal Base	1
4	EV-F8186	Pole, Beacon Mount	1
5	EV-F8188	Plate, Beacon Base Mount	1
6	EV-G001	10-32 x 1/2" PHMS	2
7	EV-G012	Nut, Hex, 1/2-13 Zn Plated	2
8	EV-G023	Locknut, Nylon Insert, 10-32	2
9	EV-G027	1/2-13 x 3.0" RHSN Gr.2	2
10	EV-G043	Plug, Tube End, 1 x 2	1
11	EV-G066	Washer, Rivet, 3/16 ID	2



PACK MULE

PROUDLY BUILT IN THE USA