

This document is intended as a reference guide for installing and using a BENDER IRDH275 ground fault detector. This document includes installation, setup, and usage instructions. For complete details, including installation, setup, settings, and troubleshooting, refer to the IRDH275 user manual, document number TGH1361en. This document is intended as a supplement and not a replacement to the complete user manual.

Only qualified maintenance personnel shall operate or service this equipment. These instructions should not be viewed as sufficient for those who are not otherwise qualified to operate or service this equipment. This document is intended to provide accurate information only. No responsibility is assumed by BENDER for any consequences arising from use of this document.



Installation

Mounting

The IRDH275 is a DIN-rail mounted device. See reverse side for dimensions.

Wiring - General

See figure 1 for basic wiring schematic. Line connections (L1 and L2) may use the schematic below for systems below 793 VAC or 650 VDC. For higher voltages, a voltage coupler is required. See section "Wiring - Voltage Couplers" on additional requirements for wiring into system connection terminals. Use minimum AWG 24, maximum AWG 12 wire. For more information, refer to the IRDH275 user manual.

⚠ DANGER

HAZARD OF ELECTRIC SHOCK, EXPLOSION, OR ARC FLASH

- Disconnect all power before servicing.
- Observe all local, state, and national codes, standards, and regulations.

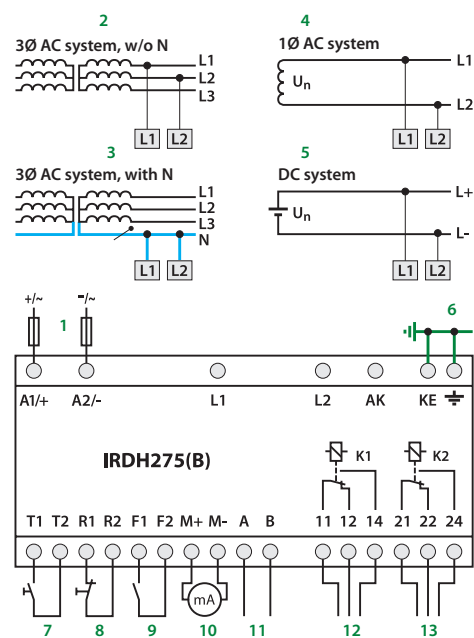

Figure 1 - IRDH275 wiring diagram with no voltage coupler

1. External supply voltage; 6A fuse recommended for internal device protection
2. Conn. 3Ø AC system without neutral
3. Conn. 3Ø AC system with neutral
4. Conn. 1Ø AC system
5. Conn. DC system
6. Equipment ground connection
7. External TEST terminal, N/O contact
8. External RESET terminal, N/O contact
9. STANDBY terminals: Closing F1/F2 will stop measurements
10. Analog outputs: 0... 400 µA on standard version, 0/4... 20 mA on "B" version
11. RS-485 interface
12. Alarm relay K1: SPDT contact
13. Alarm relay K2: SPDT contact

Wiring - Contacts

Using a normally closed or normally open contact utilizes two factors: wiring out of the proper terminal, and setting the respective contact to normally energized or deenergized operation. Refer to the chart below for relay conditions. Changing the energized state of the contact is done via the ISO SETUP > K1 and ISO SETUP > K2 options found in the main menu.

The factory default for relays K1 and K2 is normally deenergized operation.

Device Relay Conditions			
Relay Operation Setting	Device Alarm State	K1 STATE	K2 STATE
Normally deenergized mode (N/D) Non-failsafe mode "N/O" in device settings menu	Power ON, normal state (no alarms)	11-12 CLOSED 11-14 OPEN	21-22 CLOSED 21-24 OPEN
	Power OFF	11-12 CLOSED 11-14 OPEN	21-22 CLOSED 21-24 OPEN
Energized in the alarm state Relay will switch when the alarm is activated.	Power ON, normal state (no alarms)	11-12 OPEN 11-14 CLOSED	21-22 OPEN 21-24 CLOSED
	Power ON, alarm state	11-12 OPEN 11-14 CLOSED	21-22 OPEN 21-24 CLOSED
Normally energized mode (N/E) Failsafe mode "N/C" in device settings menu	Power ON, normal state (no alarms)	11-12 OPEN 11-14 CLOSED	21-22 OPEN 21-24 CLOSED
	Power OFF	11-12 CLOSED 11-14 OPEN	21-22 CLOSED 21-24 OPEN
Energized in the normal state Relay will switch when the alarm is activated, or when supply voltage to the device is lost.	Power ON, normal state (no alarms)	11-12 OPEN 11-14 CLOSED	21-22 OPEN 21-24 CLOSED
	Power ON, alarm state	11-12 CLOSED 11-14 OPEN	21-22 CLOSED 21-24 OPEN

Wiring - Voltage Couplers

System voltages greater than 793 VAC / 650 VDC require an additional voltage coupler, installed inline between the IRDH275 and the system. Figures 2 through 4 show wiring schematics for the various available voltage couplers. Locate the wiring diagram utilizing the correct voltage coupler.

Wiring - IRDH275 and AGH150W-4

The AGH150W-4 is used on DC systems up to 1600 V. Use figure 2 below for wiring. Ensure that the menu option ISO ADVANCED > AGH is set to "150." See reverse side for more information.

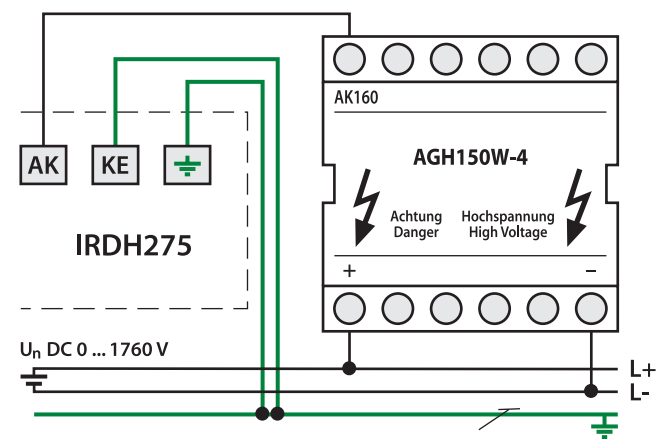

Figure 2 - IRDH275 system wiring diagram when using AGH150W-4

Wiring - IRDH275 and AGH204S-4

The AGH204S-4 is used on AC systems up to 1650 V. Use figure 3 below for wiring. Ensure that the menu option ISO ADVANCED > AGH is set to "204." See reverse side for more information.

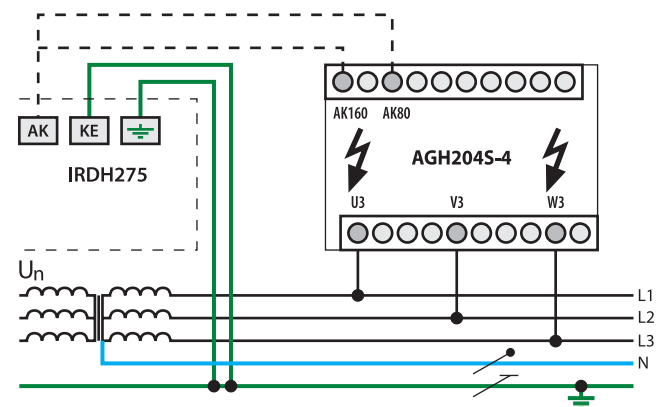

Figure 3 - IRDH275 system wiring diagram when using AGH204S-4

Wiring - IRDH275 and AGH520S

The AGH520S is used on AC systems up to 7200 V. Use figure 4 below for wiring. For systems without neutral, connect to L1. Otherwise, connect to the neutral. Ensure that the menu option ISO ADVANCED > AGH is set to "520S." See reverse side for more information.

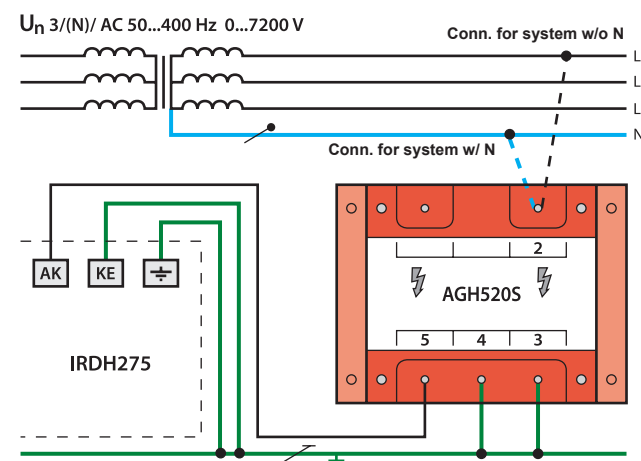

Figure 4 - IRDH275 system wiring diagram when using AGH520S

Menu Structure Flow Chart

Figure 5 shows the structure of the menu built into the IRDH275. The menu is used for viewing alarms, viewing the status of the system, and making any necessary settings changes. Use the supplied gray boxes to take note of applied settings for future reference.

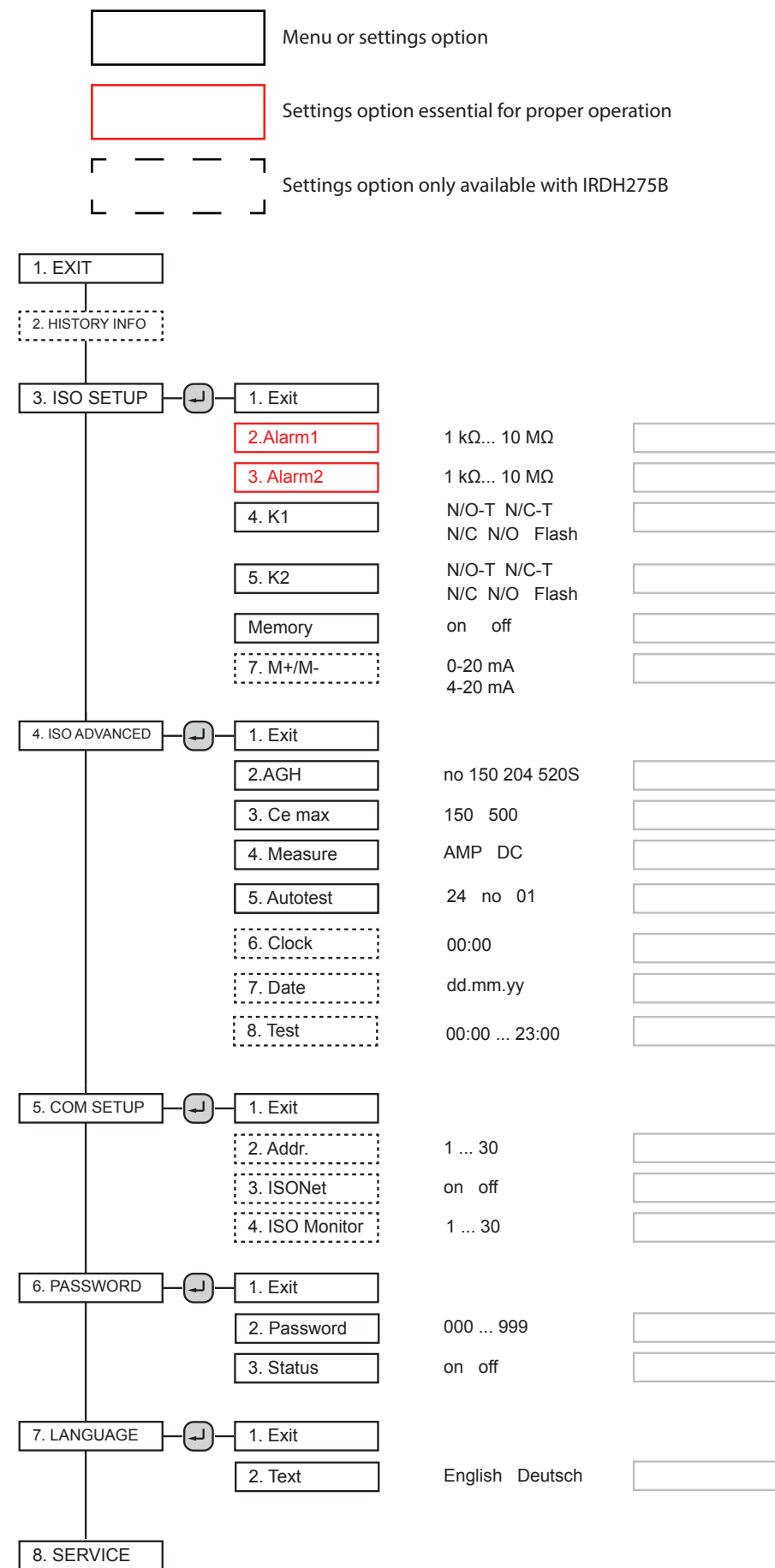

Figure 5 - IRDH275 menu flow chart

Technical Data

Refer to IRDH275 series user manual (document TGH1361en) or IRDH275 series datasheet (document NAE1012020) for detailed technical information.

Dimensions

Dimensions in inches (mm).

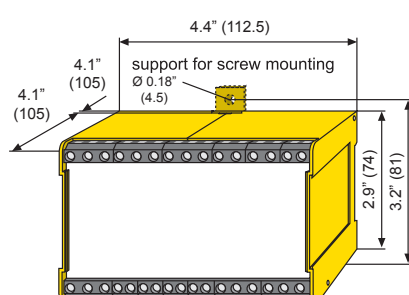
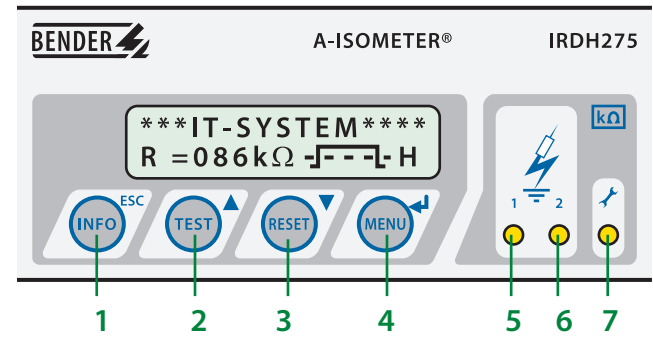

Figure 3 - IRDH275 dimensions in inches (mm)

Front Panel Display



1. INFO / ESC key: Displays system information / goes back a step in menu
2. TEST / UP key: Initiates self-test / moves up in menu
3. RESET / DOWN key: Resets device when latching mode is active / moves down in menu
4. MENU / ENTER key: Opens the main menu / confirms changes in menu
5. LED "ALARM 1": Illuminates when alarm 1 is active.
6. LED "ALARM 2": Illuminates when alarm 2 is active.
7. LED "ERROR": Illuminates when a device error has occurred.

Analog Outputs

Standard IRDH275 models feature a 0 - 400 μA analog output based on the measured insulation resistance. IRDH275B models feature a 0 - 20 mA or 4 - 20 mA output, selectable in the main menu under ISO SETUP > M+/M-. For integrating the analog outputs into control systems, refer to the equations below for the type of analog output being used.

0 - 400 μA output

$$R_F = \frac{400 \mu A \times 120 \text{ k}\Omega}{I} - 120 \text{ k}\Omega$$

R_F Insulation resistance in kΩ
 I Current output in μA

0 - 20 mA output

$$R_F = \frac{20 \text{ mA} \times 120 \text{ k}\Omega}{I} - 120 \text{ k}\Omega$$

R_F Insulation resistance in kΩ
 I Current output in mA

4 - 20 mA output

$$R_F = \frac{16 \text{ mA} \times 120 \text{ k}\Omega}{I - 4 \text{ mA}} - 120 \text{ k}\Omega$$

R_F Insulation resistance in kΩ
 I Current output in mA

Ordering Information

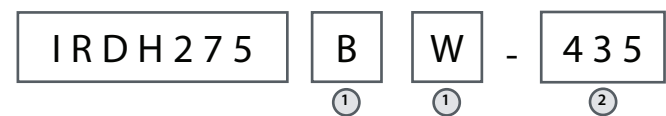

Code 1: Optional features

Modifier	Additional features
Nothing	Standard device
"B"	Real-time clock with history memory, 0(4) - 20 mA output
"W"	Additional vibration protection, greater temperature range
"BW"	Both features of the "B" and "W" above

Code 2: Auxiliary supply voltage

Modifier	Supply voltage U_s (absolute values)
"435"	DC 77...286 V / AC 42...460 Hz 88...264 V
"425"	DC 10.2...36 V
"427"	DC 19.2...72 V