



WHYNTER RESIDENTIAL PORTABLE DEHUMIDIFIER

MODEL# : RPD-410W / RPD-651W

Instruction Manual



Congratulations on your new WHYNTER product. Please read this Instruction Manual carefully before using the product to ensure proper operation. Keep this manual in a safe place for future reference.

TABLE OF CONTENTS

SAFETY PRECAUTIONS

Danger	4
Warning	4
Electrical information	5
How it works	5
Energy Saving Guide	5

CONTROL PANEL ON THE DEHUMIDIFIER

Control panel.....	6 - 7
Unit features and alerts.....	7

IDENTIFICATION OF PARTS

Identification of parts	8
-------------------------------	---

AIR FILTER INSTALLATION

Installation the air filters.....	9
-----------------------------------	---

OPERATING THE UNIT

Positioning the unit	10
Removing the collected water	11

CARE AND MAINTENANCE

Care and Maintenance of the dehumidifier	12
--	----

TECHNICAL DATA

Technical data	13
----------------------	----

TROUBLESHOOTING

Troubleshooting tips	14
----------------------------	----

WARRANTY INFORMATION

Warranty	15
----------------	----

Thank you for choosing the Whynter dehumidifier. Please follow the instructions provided in this user guide to obtain the very best performance from your dehumidifier. We trust that your Whynter dehumidifier will provide the performance and reliability that we stand for.

Your Whynter dehumidifier is designed to remove moisture in the air by condensation removal and collecting the condensation water in the internal water bucket or draining through a drain hose.

Please keep this user manual in a safe place for future reference.

DISPOSAL

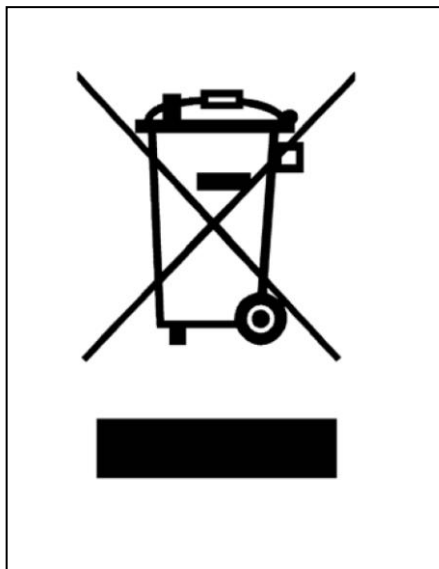

This symbol on the product or its packaging indicates that the appliance cannot be treated as normal domestic trash, but must be handed in at a collection point for recycling electric and electronic appliances. Your contribution to the correct disposal of this product protects the environment. Further information about the recycling of this product can be obtained from your local municipal authority.

Your safety and the safety of others are very important to us.

To reduce the risk of fire, electrical shock or injury when using your appliance, follow these basic precautions.

SAFETY PRECAUTIONS

To prevent injury to the user or other people and property damage, the following instructions must be followed. Incorrect operation due to ignoring of instructions may cause harm or damage.

- The seriousness is classified by the following indications.



This symbol indicates the possibility of death or serious injury.



This symbol indicates the possibility of injury or damage to property.



- Do not under any circumstances cut or remove the third (ground) prong from the power cord.
- Make sure this unit is connected to a correctly grounded power supply outlet. Do not use an extension cord or power strip.
- Do not use an excessively wet cloth, industrial solvents, oil-based products to clean this appliance.
- To avoid the risk of shock, the product should never be used in bathrooms, shower rooms, or in any other steamy or wet areas.
- Do not store or use gasoline or other flammable vapors and liquids in the vicinity of this or any other appliances.
- Do not repair, disassemble and/or modify the unit by yourself.
- Always turn off the appliance when cleaning the air filter, and transporting.
- Do not turn this appliance on and off by plugging and unplugging. Always use the ON/OFF switch.
- Do not drink or use the water collected or drained from the appliance.
- Do not remove the water bucket during operation.



- Transport the unit in an upright position only, or leave it in an upright position for at least 2 hours before first use.
- This appliance must be installed in an area protected from the element, such as wind, rain, water spray or drips.
- When using this appliance in confined spaces, such as closets, be sure to keep doors open to allow proper ventilation to prevent overheating and fire.
- The unit should not be located next to ovens, grills or other sources of high heat.
- Always place the unit on even and hard and level surface.
- Do not sit or place objects on the unit.
- Do not allow children to climb, stand or hang on the appliance. The unit could tip over and get damaged and seriously injure somebody.
- Ensure curtains or other objects are not obstructing the air intake and exhaust.
- Never insert your fingers or other objects into the air intakes and air outlets.
- Do not operate the appliance without the air filter.
- Do not use harsh chemicals to clean the filter. Dry thoroughly before inserting the air filter into the unit.
- When positioning or moving the appliance ensure that it is not turned upside down or greater than 45° or more off level.
- This appliance is designed for household, non-commercial use only. Any other use will void the warranty.
- At the end of each season, all water must be drained from the unit and air filter must be cleaned before storage.

THE MANUFACTURER DISCLAIMS ANY RESPONSIBILITY IF THE ABOVE INSTRUCTIONS ARE NOT FOLLOWED.

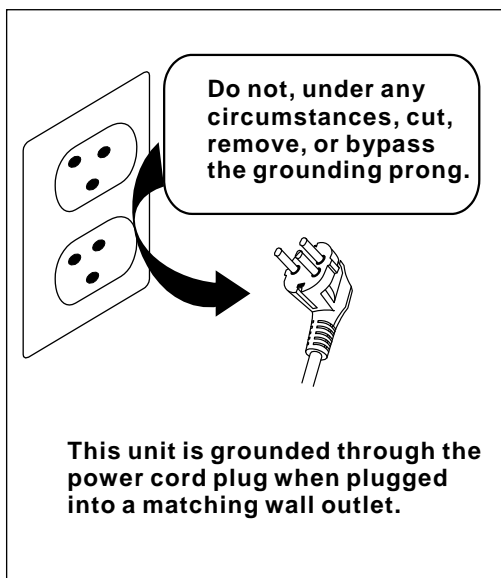

Electrical Information

- The appliance is equipped with a three-prong grounded plug on the power cord for your protection. Never modify, remove or attempt to repair the plug yourself.
- Do not pull the unit by the power cord or pull on the cord to unplug the unit. Grip the plug and pull it away from the wall receptacle.
- Ensure the power cord is not tangled, knotted or otherwise distorted before operating the unit.
- The dehumidifier must be plugged directly into a properly grounded wall outlet receptacle. If the wall receptacle you intend to use is not adequately grounded or protected by a time delay fuse or circuit breaker, have a qualified electrician install an outlet that is appropriate to local electrical codes and requirements.
- Do not use extension cords, power strips or an adapter plug with this unit
- Always unplug the unit before opening, installing or servicing.

How it Works

When the dehumidifier is started, the fan begins to pull moisture-laden air across the dehumidifying coils. The coils condense or draw moisture from the air, and air flows through the side louvers into the room as dry, warm air. Moisture removed from air is collected in a water bucket on the front of the dehumidifier.

The unit is designed to operate between 41°F (5°C), and 96°F (35°C). The "Compressor" circuit has an automatic 3 minute time delayed start if the unit is turned off and on quickly. This prevents overheating of the compressor and possible circuit breaker tripping. Make sure the tank is fitted correctly otherwise unit will not turn on.

Energy Saving Guide

This Whynter dehumidifier is an Energy Star rated appliance. Follow the guide below can help to get the best performance and efficiency from your dehumidifier.

- Do not cover the air intake and outlet.
- Do not place the unit in front of curtains or drapes- to ensure they do not obstruct the air intake.
- Keep curtains, blinds or drapes closed during the sunniest part of the day.
- Close all windows and doors.
- Indoor relative humidity should ideally be kept between 35%RH and 60%RH depending on the ambient temperature.
- Make sure the unit is on a hard and level surface.
- To prolong the compressor's life, please wait at least 3 minutes before turning the unit back on after shutting it off.
- Inspect and keep the air filter clean by cleaning regularly.
- Perform routine maintenance.

CONTROL PANEL

NOTE: The control panel of the appliance you purchased may be slightly different according to the models.

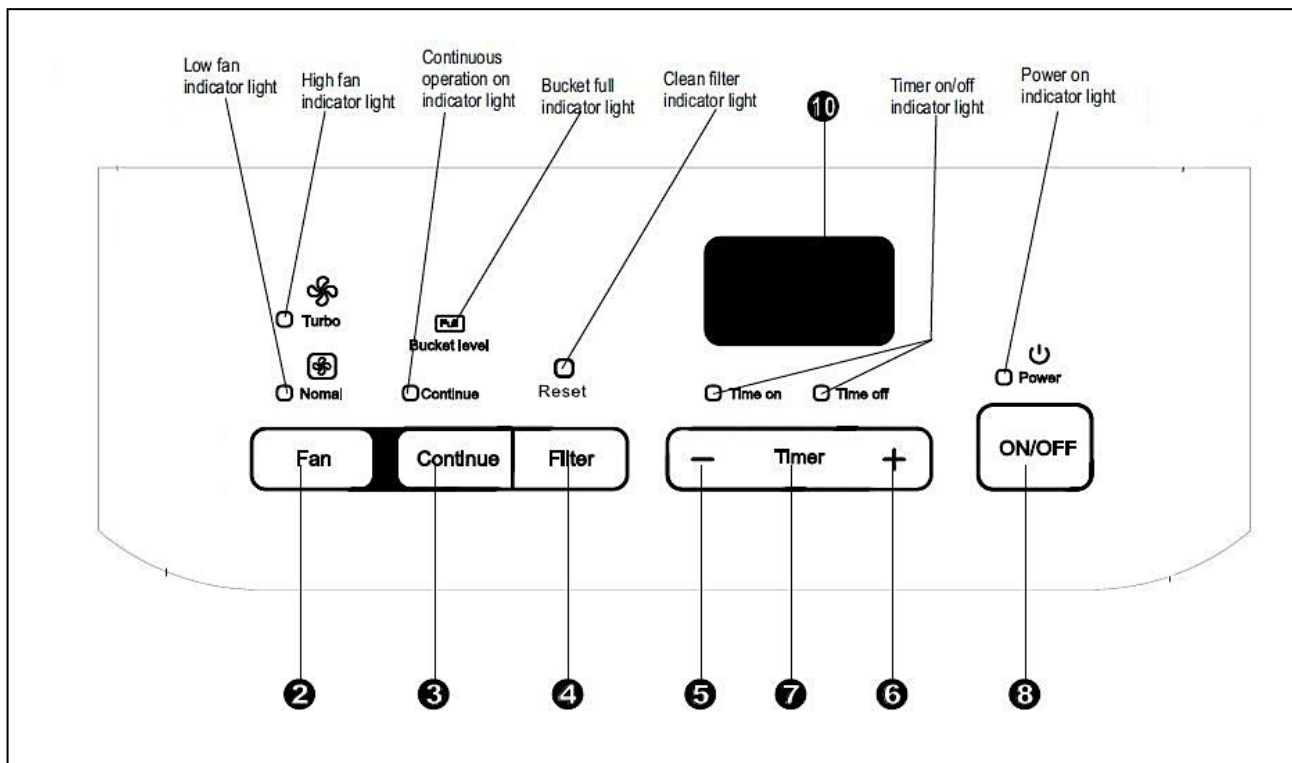

<p>2. Fan Button Controls the fan speed. The Turbo indicator light will come on when High speed is selected. The Normal indicator light will come on when Low speed is selected. Set the fan control to Turbo for maximum moisture removal. When the desired humidity level is achieved and quiet operation is preferred, you can set the fan speed to Normal.</p>	<p>3. Continue Operation Button Programs the unit to run continuously until the water bucket is full. The humidity level cannot be set (Buttons 5 and 6). The Continue indicator light will come on when this mode is selected.</p>
<p>4. Filter Reset Button The check filter feature is a reminder to clean the air filter for efficient operation. Filter indicator light will come on after approximately 250 hours of operation. After the filter is cleaned and replaced, reset the unit by pressing the Filter Button and the Reset indicator light will go off.</p>	<p>5 / 6. (-) / (+) Humidity Control / Timer Button The humidity level can be set within a range of 35%RH (Relative Humidity) to 85%RH in 5% increments.</p>
<p>7. Timer Button The Timer button enables you to initiate the Auto-start and Auto-stop feature. Use the (-) and (+) buttons to increase or decrease the desired time interval in 0.5 hour increments. To cancel the selected timer setting, press the Timer button again or turn the unit off.</p>	<p>8. On/ Off Button Turns the dehumidifier on and off.</p>

10. Display Screen

The display screen shows a number of different indications depending on the selection function.

- Shows the set % relative humidity level from 35%RH to 85%RH.
- Shows auto start/stop time (0~24 hours).
- After the option settings are completed, the display shows the approximate room humidity level in a range of 30%RH (Relative Humidity) to 90%RH

The display screen may also display the following alerts:

Error Codes and Protection Codes:

AS- Humidity sensor error: Power off the unit, then unplug it for 15 minutes. Plug in and power on. If error repeats, call for service.

ES- Temperature sensor error: Power off the unit, then unplug it for 15 minutes. Plug in and power on. If error repeats, call for service.

P1- Unit is defrosting: Allow the unit time to defrost. The error will clear after the unit is self-defrosted.

P2- Bucket is full or bucket is not in right position: Empty the water bucket and reinstall it properly.

E1- Unit Error: Power off the unit, then unplug it for 15 minutes. Plug in and power on. If error repeats, call for service.

Unit Features and Alerts

Bucket Level Light

Bucket level indicator light will illuminate when the bucket is full and needs to be emptied. This light will also illuminate when the bucket is removed or not properly inserted. The dehumidifier shuts off within 30 seconds of the indicator light illuminating.

Auto Shut Off

When the selected humidity level is reached, the dehumidifying function will shut off automatically and the fan will run continuously.

Auto Defrost

In the event frost builds up on the evaporator coils, the compressor will cycle off and the fan will continue to run until the frost is evaporated.

Three Minute Cycle Down Function

After the unit has stopped, it cannot be restarted for 3 minutes. This is to ensure the unit completes its cycles down before reactivation.

Auto-Restart

In the event of a power outage, unit restarts at the previously set function mode and settings when power is restored.

Setting the Timer (Auto-start/stop)

Setting Auto Stop timer

With the unit is operating in any function mode, press the TIMER button. The TIME OFF light will come on. Then set the desired time delay OFF hours by pressing the \oplus and \ominus buttons. The time increments are at 0.5 hour to up to 10 hours, then at 1 hour to 24 hours. When the delay time set has elapsed, the unit switches off. To cancel the delayed switch off function, turn off the unit.

Setting Auto Start timer

With the unit is turned off, press the TIMER button. The TIME ON light will come on. Then set the desired time delay OFF hours by pressing the \oplus and \ominus buttons. The time increments are at 0.5 hour to up to 10 hours, then at 1 hour to 24 hours. When the delay time set has elapsed, the unit switches on. To cancel the delayed switch off function, turn off the unit.

When the Auto start & Auto stop times are set within the same program sequence, TIME ON and TIME OFF indicator lights illuminate identifying both ON and OFF times are programmed.

When the display shows P2, the Auto Stop/ Start function is canceled.

Silver Ion Air Filter

Your Whynter dehumidifier is equipped with an advanced Silver Ion air filter which is designed to not only trap dust and large particles but also kills bacteria in the air and controls the growth of microbes, such as virus, fungi and spores.

IDENTIFICATION OF PARTS

All the pictures in the manual are for explanation purposes only. The actual shape of the unit you purchased may be slightly different, but the operations and functions are the same.

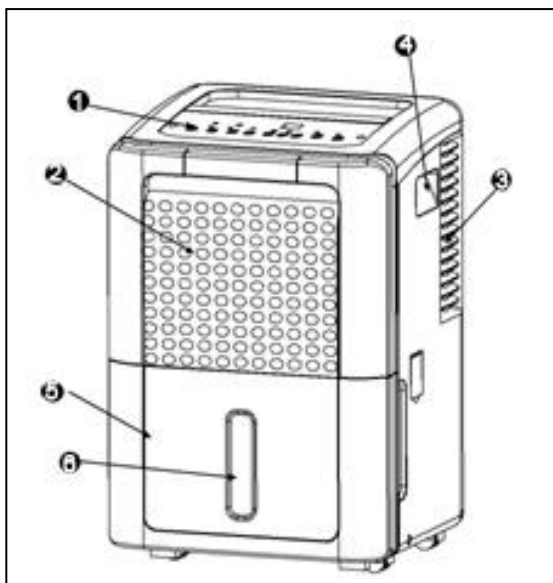

Model: RPD-651W

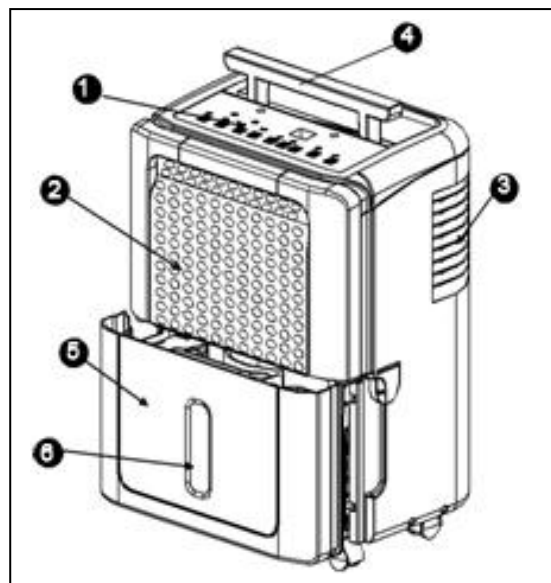

Model: RPD-401W

Front (Above)

1. Control Panel
2. Air Intake Grille
3. Air Outlet Vent
4. Handle
5. Removeable Water Bucket
6. Water Level Window

Rear (Below)

1. Drain Hose Outlet
2. Casters
3. Power Cord and Plug
4. Power Cord Bracket (RPD-651W) Power Cord Strap (RPD-401W)

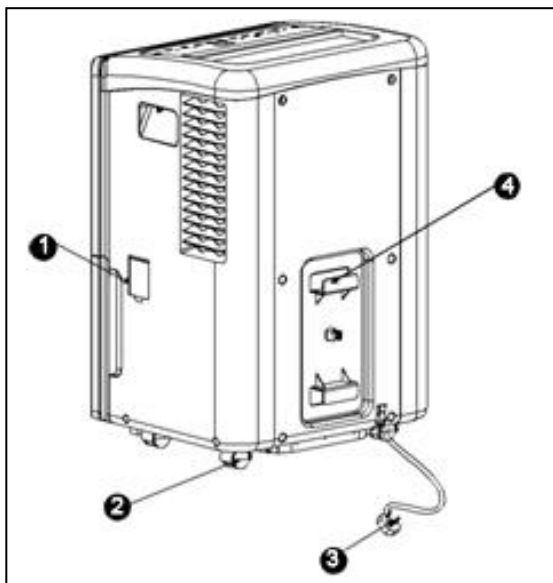

Model: RPD-651W

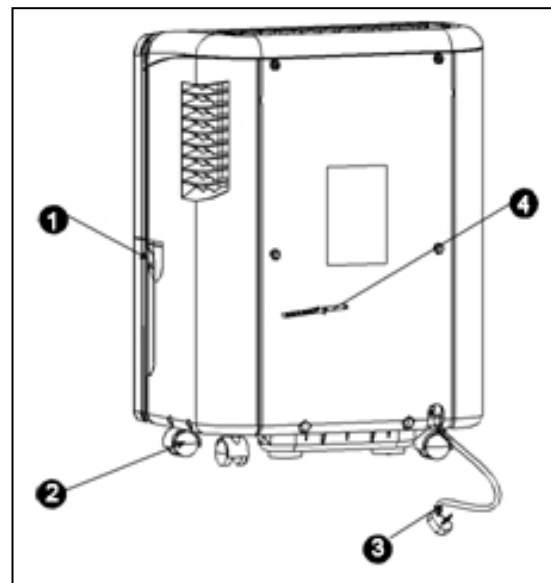

Model: RPD-401W

AIR FILTERS INSTALLATION

Your Whynter portable dehumidifier is equipped with a washable Pre-Filter and a Silver Ion Filter. The washable Pre-Filter removes large particles such as dust, pet hair and dander. The Silver Ion air filter which is designed to kill bacteria in the air and control the growth of microbes, such as virus, fungi and spores. It is recommended you replace the Silver Ion Filter every two to three months or as needed. Follow the steps below to install the filters.

WARNING: NEVER OPERATE THE DEHUMIDIFIER WITHOUT THE PRE-FILTER

1. Pull up the pre-filter frame

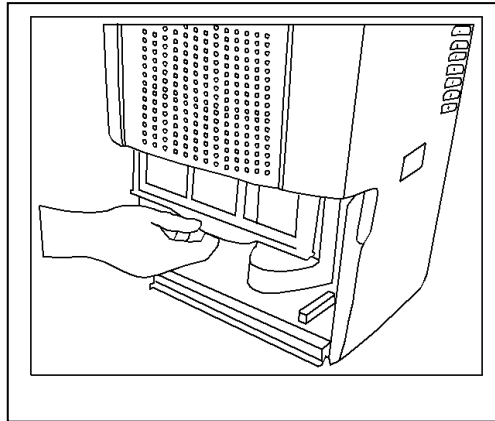

2. Remove the Pre-Filter from the filter frame.
3. Place the Silver Ion Filter on the Pre-Filter.
4. Reattached the filter frame.
5. Insert the assembled filter frame into the unit.

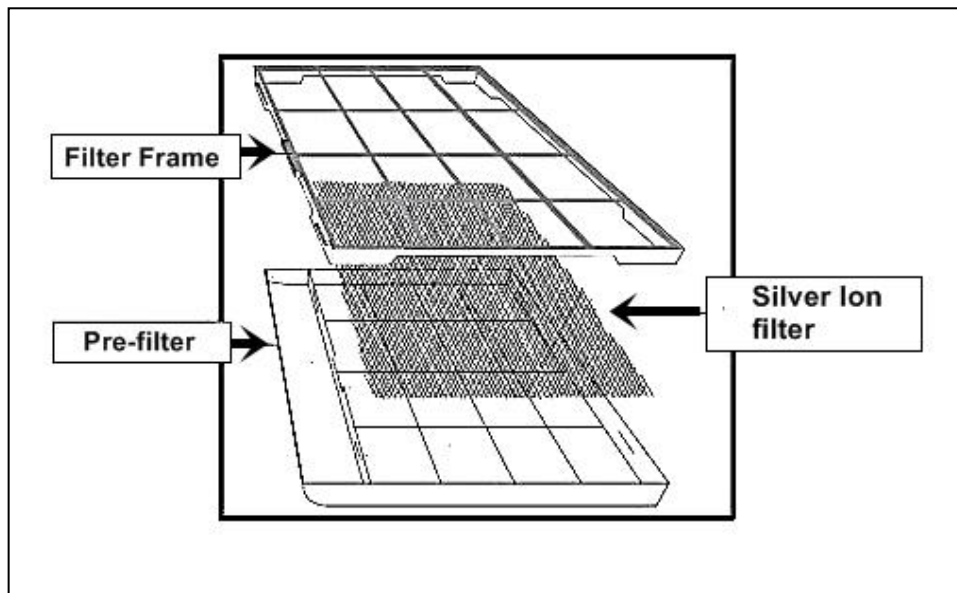

OPERATING YOUR DEHUMIDIFIER

Positioning the unit

- This dehumidifier is intended for indoor residential applications only and should not be used for commercial or industrial applications.
- Place the dehumidifier on a smooth, hard and level floor strong enough to support the unit with a full bucket of water.
- Do not attempt to roll the unit over objects.
- Avoid placing the unit in an area where the temperature will fall below 40F. The coils may become covered with frost at temperatures below 40F and may reduce performance.
- Do not place the unit near clothes dryer, heater or radiator.
- The dehumidifier must be operated in an enclosed area.
- Shut all doors, windows and openings to your target dehumidifying space for maximum performance
- Allow at least 10" of air space on all sides of the unit for good air circulation.

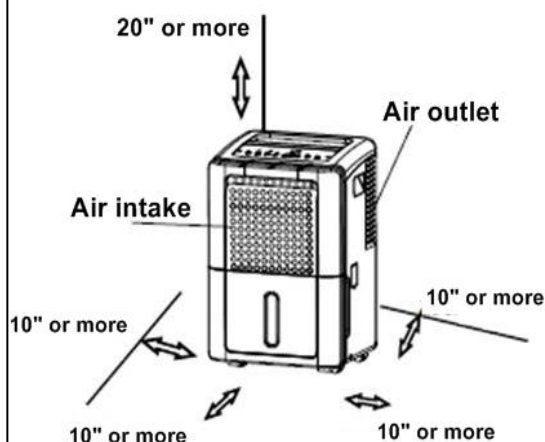

NOTE:

When using the dehumidifier for the first time, operate the unit continuously for 24 hours.

This unit is designed to operate in environment between 41°F and 95°F.

Dehumidifiers working in a basement will have little or no effect on adjacent enclosed rooms such as closets, unless there is enough circulation of air in and out of the enclosed area.

If the unit has been switched off and needs to be switched on again, allow approximately three minutes for the correct operation to resume.

Select a suitable location and make sure you have easy access to the electrical outlet.

Ensure the air filter and water bucket are correctly installed before switching the unit on.

Always be careful when moving the unit with a full water bucket.

Ensure that the safety requirements and warnings detailed in this user manual are followed when operating this unit.

Removing the collected water

There are two ways to remove the collected water.

1. Manual drain

- When the unit is off and the bucket is full, the unit will beep 8 times and the Bucket Level indicator light will flash, the digital display will also indicate P2.
- When the unit is on and the bucket is full, the compressor shuts off but the fan runs for an additional 30 seconds to dry any moisture on the condenser. The unit will then beep 8 times and the Bucket Level indicator light will flash, the digital display will also indicate P2.
- Slowly pull out the bucket. (Fig 5) Grip the left and right handles securely, carefully pull the bucket out to prevent water spillage. (Fig 6) Do not put the bucket on the floor as the bottom of the bucket is uneven and it may tip.
- Dispose the water (Fig 7) and reinstall it to the dehumidifier. The bucket must be installed securely for the unit to operate.
- The unit will restart when the bucket is restored in its correct position.

NOTES:

- When the bucket is removed, do not touch any parts inside of the unit. Doing so may damage the unit.
- Be sure to push the bucket gently all the way into the unit. Hitting the bucket against anything or failing to push it in securely may cause the unit to malfunction.
- When the bucket is removed, check if there is any excess water at the base of the unit. Wipe any visible water inside the unit before replacing the bucket.

2. Continuous drain

Water can be automatically emptied into a floor drain by attaching the unit with a water hose(ϕ 24mm) (included).

- Remove the water bucket from the unit and set aside.
- Lift up the Drain Hose Outlet cover located on the right side of the unit (Fig.8)
- Insert the female threaded end of the hose to the Drain Hose Outlet. (Fig.9a)
- Grip the hose from inside the unit and screw the hose onto the threaded portion of the tray located in the bucket opening.(Fig.9b)
- Make sure the hose is securely fastened to prevent leakage. Direct the hose toward a drain or other suitable drainage outlet. Make sure that there are no distortions with the hose that may stop the water flow.
- Reinsert the water bucket back in the unit and make sure that it is inserted securely.(Fig.9c)
- Select the desired humidity setting and fan speed on the unit for continuous draining to start.

NOTE: If the unit stops operating, check if the Bucket Level light is illuminated. If it is, remove the bucket and empty the water and then check the seal between the hose and the drip tray. If there is a leak, replace the hose gasket and re-tighten the hose.

1. Pull the bucket out carefully.

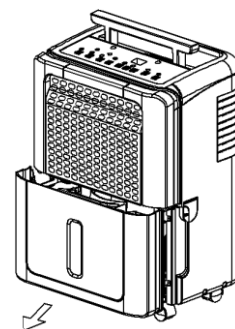

Fig.5

2. Hold both sides of the bucket evenly and pull it out from the unit completely.

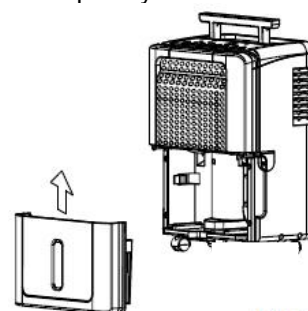

Fig.6

3. Pour the water out.

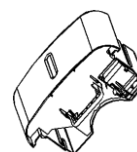
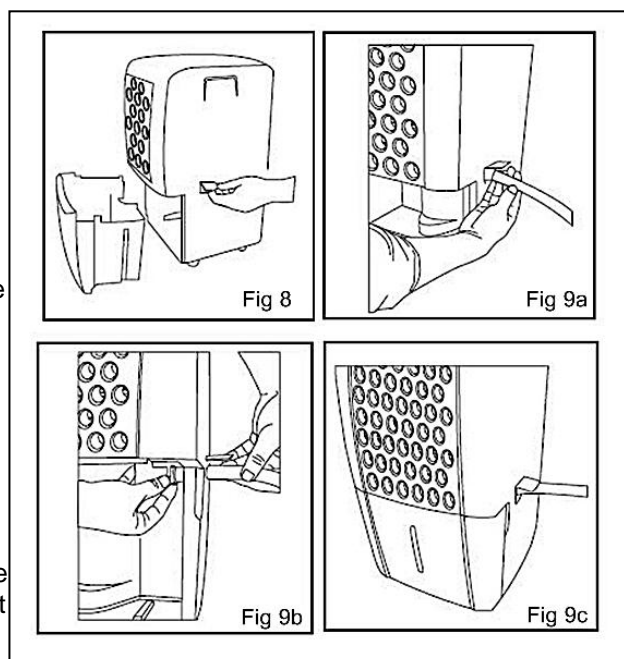

Fig.7



CARE AND MAINTAINANCE

ALWAYS turn off and unplug the dehumidifier before cleaning.

1. Cleaning the air grille and main unit

- Use a damp cloth to wrap the main unit or use water and a mild detergent. Do not use bleach, chemicals or abrasives.
- Do not splash water directly onto the unit. Doing so may cause an electrical shock, cause the insulation to deteriorate, or cause the unit to rust.
- Use a vacuum attachment or brush to clean the air intake and outlet grilles.

2. Cleaning the bucket

Clean the bucket to prevent growth of mold, mildew and bacteria every two weeks.

- Fill the bucket with clean warm water and add mild detergent to the water.
- Dry thoroughly before reinserting the bucket to the main unit.

NOTE: Do not clean the bucket in a dishwasher.

3. Cleaning the air filter

To ensure the air intake is filtered properly and to assure that your dehumidifier runs efficiently, it is recommended to clean the air filter at least once every two weeks.

- Remove the bucket and pull filter downwards. (Fig 10)
- Use a vacuum cleaner or tap the filter lightly to remove loose dust and dirt.
- Rinse the air filter under warm or cold running water (no hotter than 100F.)
- Dry thoroughly before reinserting the air filter.
- Reinstall the air filter and replace bucket securely.

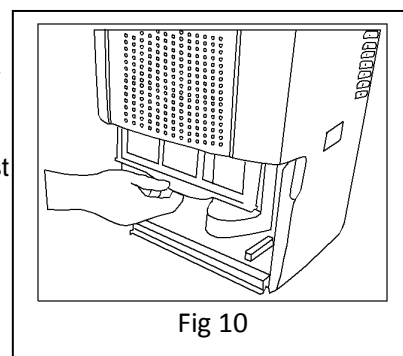

Fig 10

CAUTION:

NEVER operate the dehumidifier without an air filter in place.

4. End of Season Storage

- After turning off the unit, wait 24 hours before emptying the bucket to allow excess moisture to drain into the bucket.
- Clean the main unit, water bucket and air filter as detailed above.
- Wrap the cord around the power cord bracket (Fig.12a) or wrap the cord and secure it with the power cord strap (Fig.12b).
- Cover the unit with the original plastic bag that came with the unit or any appropriate dust cover.
- Store the unit upright in a dry, well-ventilated place.

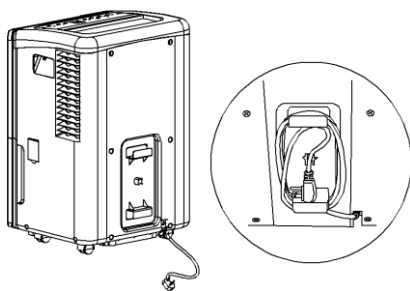

Fig. 12a

Model: RPD-651W

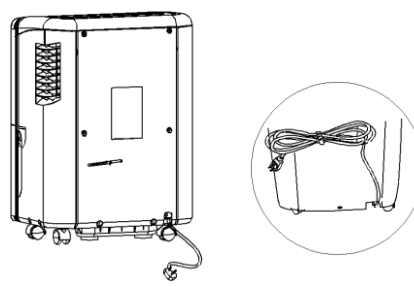

Fig. 12b

Model: RPD401W

TECHNICAL DATA

	RPD-410W	RPD-651W
Dehumidifying capacity	40 pints/ day	65 pints/ day
EEV (Liters per kW-Hour)	1.5	1.8
Power supply	115v/ 60Hz	115v/ 60Hz
Maximum power input	490 Watts	710 Watts
Maximum input	4.8 Amps	6.6 Amps
Refrigerant	R-134A	R-410A
Air flow M3/H(CFM)	270/220	370/330
Fan speeds	2 (H & L)	2 (H & L)
Unit Dimensions	14.5" x10.5" x20"	15" x 14" x24"
Unit Weight	30 lbs	43 lbs

TROUBLESHOOTING

Problem	Possible Causes	Solutions
The dehumidifier does not operate.	<p>Power failure / outage.</p> <p>The automatic switch, line fuse, or breaker has been tripped.</p> <p>The power supply voltage is too low.</p> <p>The power cord is damaged.</p> <p>The dryness level you selected has been reached.</p> <p>Water bucket is full or not positioned properly.</p>	<p>Restore the power supply.</p> <p>Flip the switch / change the fuse / turn the breaker back on. Also note that you may have too many appliances drawing power on one circuit, you may need to move the other appliances to another circuit.</p> <p>Move the unit onto another circuit with the correct voltage.</p> <p>Call for service. Only authorized personnel should replace damaged power cord or power plug.</p> <p>If you want to remove more moisture, press the 'Continue' button to run the unit continuously.</p> <p>Empty water bucket and insert the bucket to the unit properly.</p>
The dehumidifier runs too much.	<p>Windows or doors near dehumidifier are open.</p> <p>Area to be dehumidified is too large.</p> <p>Air movement through dehumidifier is blocked. Air grill may be dirty.</p> <p>Continuous mode is on.</p>	<p>Close all windows or doors.</p> <p>You may need an additional dehumidifier for area.</p> <p>Clean the air filter.</p> <p>The unit must be placed in a space that does not restrict air flowing into the rear coil or out of the front grill.</p> <p>Set the RH% level and the unit will stop when the set RH% is reached.</p>
The dehumidifier runs but the room is not dry enough.	<p>Humidity setting (RH%) is too high.</p> <p>The dehumidifier does not have sufficient clearance to operate.</p> <p>Room temperature is too low.</p> <p>Windows or doors are opened.</p>	<p>Set the humidity level to a lower RH% or choose Continue for maximum dryness.</p> <p>Ensure there is at least 10" of clearance for proper ventilation.</p> <p>The unit will not operate satisfactorily if the room temperature is below 41 °F(5 °C).</p> <p>Close windows or doors.</p>
Frost appears on the coils above the bucket.	<p>The dehumidifier has been turned on recently.</p> <p>Room temperature is too low.</p>	<p>This is normal due to refrigerant rushing through the coil. Frost will usually disappear within 60 minutes.</p> <p>The unit will not operate satisfactorily if the room temperature is below 41 °F(5 °C).</p>
The dehumidifier makes loud noise.	Unit not level.	Shut off the unit and it sit on level surface for at least 6 hours.
The dehumidifier leaks.	<p>Continuous drainage hose is loose.</p> <p>Cracked water bucket.</p>	<p>Secure the drain hose.</p> <p>Contact customer service.</p>

ONE YEAR LIMITED WARRANTY

This WHYNTER dehumidifier is warranted, to the original owner within the 48 continental states, for one year from the date of purchase against defects in material and workmanship under normal use and service. Should your WHYNTER dehumidifier prove defective within one year from the date of purchase, return the defective part or unit, freight prepaid (within two months of purchase; after two months to one year, customer will be responsible for freight cost to Whynter's service department), along with an explanation of the claim to Whynter LLC. Please package the dehumidifier carefully in its original packaging material to avoid damage in transit. Please retain the original box and packaging material. Under this warranty, Whynter will repair or replace any parts found defective. This warranty is not transferable. After the expiration of the warranty, the cost of labor and parts will be the responsibility of the original owner of the unit.

THIS WARRANTY DOES NOT COVER:

- Acts of God, such as fire, flood, hurricanes, earthquakes and tornadoes.
- Damage, accidental or otherwise, to the dehumidifier while in the possession of a consumer not caused by a defect in material or workmanship;
- Damage caused by consumer misuse, tampering, or failure to follow the care and special handling provisions in the instructions.
- Damage to the finish of the case, or other appearance parts caused by wear.
- Damage caused by repairs or alterations to the product by anyone other than authorized by the manufacturer.
- Freight and Insurance cost for the warranty service.

DISCLAIMER OF IMPLIED WARRANTIES; LIMITATION OF REMEDIES

CUSTOMER'S SOLE AND EXCLUSIVE REMEDY UNDER THIS LIMITED WARRANTY SHALL BE PRODUCT REPAIR OR REPLACEMENT AS PROVIDED HEREIN. CLAIMS BASED ON IMPLIED WARRANTIES, INCLUDING WARRANTIES OF MERCHANTABILITY OR FITNESS FOR A PARTICULAR PURPOSE, ARE LIMITED TO ONE YEAR OR THE SHORTEST PERIOD ALLOWED BY LAW, BUT NOT LESS THAN ONE YEAR. WHYNTER SHALL NOT BE LIABLE FOR CONSEQUENTIAL OR INCIDENTAL DAMAGES SUCH AS PROPERTY DAMAGE AND INCIDENTAL EXPENSES RESULTING FROM ANY BREACH OF THIS WRITTEN LIMITED WARRANTY OR ANY IMPLIED WARRANTY. SOME STATES AND PROVINCES DO NOT ALLOW THE EXCLUSION OR LIMITATION OF INCIDENTAL OR CONSEQUENTIAL DAMAGES, OR LIMITATIONS ON THE DURATION OF IMPLIED WARRANTIES, SO THESE LIMITATIONS OR EXCLUSIONS MAY NOT APPLY TO YOU. THIS WRITTEN WARRANTY GIVES YOU SPECIFIC LEGAL RIGHTS. YOU MAY ALSO HAVE OTHER RIGHTS THAT VARY FROM STATE TO STATE.

To obtain service or information, contact
Whynter LLC via email at service@whynter.com or call
866-WHYNTER.

Product contents and specifications may change without notice.

Copyright © 2010 Whynter LLC

www.Whynter.com