



## Quick guide Technical parameters

**multimes**

## Three-phase network measuring device

**4F96 LCD**



**You partner for  
network analysis**

# Table of contents

<b>1 Introduction</b> .....	3
<b>2 Inserting the battery</b> .....	8
<b>3 Installation and assembly</b> .....	10
<b>4 Setting transformer parameters</b> .....	13
<b>5 Setting the eBus address</b> .....	15
<b>6 Operating structure</b> .....	16
<b>7 System operation</b> .....	18
<b>8 Connection chart/terminal assignment</b> .....	20
<b>9 Technical data</b> .....	22
<b>Declaration of conformity</b> .....	29

---

© KBR GmbH  
Subject to change

# 1 Introduction

## Thank you for choosing this KBR quality product.

In order to familiarize yourself with the operation and configuration of the device so that you are able to make use of the entire functionality of this high-quality product, we recommend that you read this manual thoroughly.

The individual chapters serve to explain the technical details of the device and show how to avoid damage by means of proper installation and commissioning.

## 1.1 Quick guide

This guide describes the device version **multimes 4F96**. You can order the longer and more comprehensive manual version by specifying the order number EDEBDA0192 \_xxxx-x\_DE400.

This guide is included in the scope of delivery of the device and must be accessible for the user at all times (e.g. in the switchgear cabinet). Even when the device is resold to third parties, the manual remains part of the device.

Although we used the utmost care in assembling this user manual, we would like to thank you in advance for notifying us about any errors or ambiguous descriptions you might notice.

## 1.2 Intended use

This device serves for the monitoring of all important parameters in a three-phase network.

In addition to the Basic version multimes 4F96-0, you can choose from two additional device versions with extended interface and storage capacity. A detailed description is given in the multimes technical data sheet.

Note that the device does not replace close monitoring of the respective parameters by the operator.

**Depending on the optional board (Opt.),  
the device has the following functionality:**



**Note**

multimes 4F96 LCD is available with different optional boards. This user manual describes all options possible. To see which device version you have, please refer to the nameplate.

- **Option 0:**  
no optional board
- **Option 1:**  
optional board with Modbus RS485,  
real-time clock, backup battery, 2x relay outputs
- **Option 2:**  
optional board with Modbus RS485
- **Option 3:**  
optional board with KBR eBus RS485, Modbus RS485
- **Option 4:**  
optional board with Modbus Ethernet, real-time clock,  
backup battery, 2x relay outputs
- **Option 5:**  
optional board with Profibus DP, real-time clock, backup battery
- **Option 6:**  
optional board with KBR eBus Ethernet, real-time clock,  
backup battery, 2x relay outputs
- **Option 7:**  
optional board with KBR eBus RS485, Modbus RS485,  
real-time clock, backup battery, 2x relay outputs

### 1.3 Explanation of safety relevant symbols

This user manual contains notes that must be observed for your personal safety and to avoid damage to equipment. These notes are identified by a warning sign or information symbol, depending on the degree of hazard they represent.



#### Warning

"Warning" means that death, major injuries or damage may occur in case the appropriate safety measures are not taken.



#### Caution

"Caution" means that minor injuries or damage may occur in case the appropriate safety measures are not taken.



#### Note

"Note" is an important information on the product, operation or the respective part of the user manual to which special reference is made.

### Disclaimer

The content of this user manual has been carefully reviewed in terms of the hardware and software described. Certain deviations, however, cannot be excluded, and the manufacturer is not liable for complete conformity. The specifications made in this user manual are checked on a regular basis, necessary corrections will be included in the next revision.

### 1.4 Safety notes

In order to prevent operating errors, operation of this device is kept as simple as possible. This way, you will be able to quickly start working with the device.

In your own interest, however, you should read the following safety notes carefully.

During assembly, the applicable DIN / VDE regulations must be observed!

Power supply connection, setup and operation of the device must only be performed by qualified personnel. Qualified personnel in accordance with the safety notes in this user manual are persons authorized to set up, ground and mark devices, systems and circuits in accordance with all applicable standards and regulations.

To avoid the hazard of fire and electrical shock, the device must not be subject to rain or other humidity!

Before the device is connected to its power supply, you will have to check whether the local power supply conditions comply with the specifications on the manufacturer's label.



### Caution

A wrong connection may destroy the device!

When connecting the device, observe the connection chart (see chapter "Connection chart") and make sure that no voltage is applied to the connection lines. Only use proper wiring material and watch the correct polarity when wiring!

In order to ensure proper and safe operation of the product, it must be transported, stored, installed and mounted in accordance with the specifications and operated and maintained carefully.

A device showing visible damage must by all means be considered as unfit for operation and must be disconnected from the power supply!

Error detection, repairs and maintenance work may only be carried out in our facilities or after contacting our service team. Every warranty obligation of the manufacturer expires if the device is opened without written consent from our service team. Proper operation can no longer be guaranteed!

Opening the device may expose parts under voltage. Capacitors in the device may still be loaded even if the device has been disconnected from all voltage sources.

It is generally not allowed to operate the open device!

In facilities susceptible to lightning, lightning protection must be provided for all input and output lines!

## 1.5 Product liability

You have acquired a high-quality product.

In its manufacture, only components of the highest reliability and quality were used.

Each device is subject to long-term testing before it is delivered.

Regarding product liability, we refer to our general terms and conditions for electronic equipment, which you can find at [www.kbr.de](http://www.kbr.de)

The warranted properties of the device apply only if it is operated in accordance with its intended use!

## 1.6 Disposal

Please properly dispose of devices that are defective, outdated or no longer in use.

At your request, we will be pleased to dispose of the devices for you.

## 2 Inserting the battery

### 2.1 Device memory, battery-buffered (optional):

The device is equipped with an internal data memory, which is battery buffered to preserve long-term data. To prevent it from being discharged, this backup battery (e.g. Varta CR 2032) is not built in when the device is delivered, but included separately in the delivery.



#### Caution

Before the initial commissioning of the device, please insert the backup battery first (as described in the following section), as otherwise all buffered data would be lost in case of a power failure.



## 2.2 Inserting or replacing backup battery:

1. Disconnect the device from the power supply and all other connections.
2. Remove the rear housing cover with a suitable screwdriver (6 screws at the rear side).
3. Carefully pull out the lower circuit board with the backup battery in the battery holder on it to the back.
4. When replacing a battery, remove the empty battery from the clamping bracket with a tool.
5. Push the new battery into the clamping bracket and make sure that it is inserted correctly and has the right polarity.
6. Reinsert the lower circuit board in the respective slot (pay attention to correct pin connector contact).
6. Put the rear housing cover back on and fasten it with the 6 rear side screws.
7. Reconnect the device to the power supply and all other connections.



### Caution

When the battery is empty or has been removed, there is no supply voltage. In this case, not only the storage data are lost, but the time settings have to be reset as well!

## 3 Installation and assembly

### 3.1 Device assembly

During installation, the applicable DIN / VDE regulations must be observed!

Before the device is connected to the power supply, please check whether the local power supply conditions comply with the specifications on the manufacturer's label. A wrong connection may destroy the device. A different power frequency influences the measurement accordingly.

The device must be connected in accordance with the connection chart.

In case the facility is subject to lightning hazard, lightning protection measures for the power supply input must be implemented.



#### Caution

The control voltage as well as the applied measuring voltage of the device must be protected by means of a back-up fuse. When connecting the current transformer, the direction of the energy flow and the correct assignment to the voltage path must be observed!

For the wiring of the pulse output, we recommend to exclusively use shielded twisted pair material, to avoid disturbance (e.g. installation line I-Y(ST) Y 2x2x0.8mm, whereas the shielding may only be connected on one side).

During installation, please also observe our notes on safety measures against overvoltage and lightning in the chapter "Protective measures" of this manual.

**Note**

**You should take the following points into consideration when connecting the device to the three-phase network to be measured:**

- Energy flow direction
- Assignment
- Measuring voltage input / current transformer input

### 3.2 Rotating field

The unit can be operated in a clockwise or a counter-clockwise rotating field. When switching on the device's power supply, multimes 4F96 LCD automatically checks the rotating direction. Rotary field check:

1. Connect only the measuring voltage to the device (Umeas see nameplate).
2. Switch on the device by applying voltage to the power supply connections (L and N). Immediately after the device has been switched on, it will check the power supply rotating direction.
3. The rotating field is displayed in the menu UPH-PH, submenu Angle.
4. For a clockwise rotating field, the display shows L1 **0**, L2 **120** and L3 **240** degrees.
5. If you want to change the rotating direction from clockwise to counter-clockwise, you only have to exchange two terminals, i.e. two phases. Then, switch the device OFF and ON again. The display now shows the correct voltage and the device starts measuring automatically.
6. Then, check again whether the assignment of voltage path L1 and current path L1, as well as for all other phases, is still correct.

### 3.3 Asymmetry

The rotating field is displayed in the menu UPH-PH, submenu angle / asym.

The voltage asymmetry is displayed according to standard EN 6100-4-30:2003.

Shows the asymmetric load of the three phase network. The display **Asymmetry** is shown and the value is displayed in %.

### 3.4 Current transformer connection

#### ■ Energy flow direction

When mounting the transformer, observe the current flow or energy flow direction. If the current transformer is mounted the wrong way, the measured value will be negative.

Prerequisite is that energy is consumed.

#### ■ Assignment of measuring voltage input / current transformer input

The current transformer on terminal 20/21 (k1/l1) must be arranged in the phase where the measuring voltage for terminal 10 (L1) is measured. The same applies to the other transformer and measuring voltage connections.

The phase sequence can be checked with the multimes 4F96 LCD as follows:

1. Switch back to the main menu "I".
2. Connect the current transformer to the corresponding wires.
3. The device will display only positive currents when connection and energy flow direction are correct.
4. . If connections are wrong, all currents will be negative. Interchange the connections until the display shows correct values.



#### Caution

Before any interchanging, current transformers must be shorted out!

## 4 Setting transformer parameters

The menu navigation of the multimes 4F96 LCD is self-explanatory. The operator is guided and supported by the device through operating instructions on the display for that particular situation.

As an example of the basic procedure of programming, the function Setting transformer parameters in the menu U Phase – N will be looked at more closely.

After pressing the **F2** (PARR) button, the following is displayed in the hot key area:

F1	F2	F3	F4	
↩	UICU	Lim1	Lim2	Display hot key area
			Configuring limit 2	
		Configure limit 1		
	Display and processing for voltage transformer			
Return				

After pressing the **F2** (UICI) button, the following is displayed in the hot key area:

F1	F2	F3	F4	
↩	UICI		EDIT	Display hot key area
		Configure transformer ratio voltage transformer		
	Change to editing current transformer			
Return				

After pressing the **F4** (EDIT) button, the following display appears in the hot key area of the display:

F1	F2	F3	F4	
←	↓	→	+	Display hot key area
			+ Value input	
		Continue to next digit		
	Scroll through lines in the value area			
Return				

If the setting was changed, the following display appears after the second line in the hot key area of the display when the ↓ key (scrolling function) is pressed:

F1	F2	F3	F4	
NO	↓	YES		Display hot key area
		Leave settings menu and save		
	Scroll through lines in the value area			
Leave setting menu without saving				

## 4.1 Setting range

Measuring voltage, primary	1 V to 9999 kV
Measuring voltage, secondary	100 V to 500 V
Measuring current, primary	1 A to 99.99 kA
Measuring current, secondary	1 A to 5 A

## 5 Setting the eBus address:

Main menu Extras, submenu Basic parameters 2 (can be selected by pressing **F4** )

base Para (2)				Menu ticker (after pressing a key, see hot key area)
<b>F1</b>	<b>F2</b>	<b>F3</b>	<b>F4</b>	
←	Time	Bus	+	Display hot key area
			Other base para (3)	
		Set bus parameters (baud rate, address, log etc.)		
	Set time (time, date, daylight-saving time)			
Return				

## 6 Operating structure

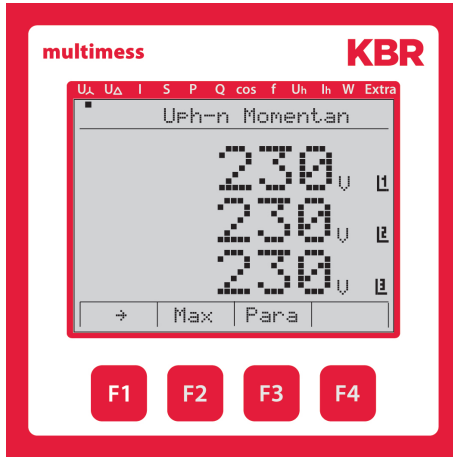

The following overview gives you an idea of the operating structure.



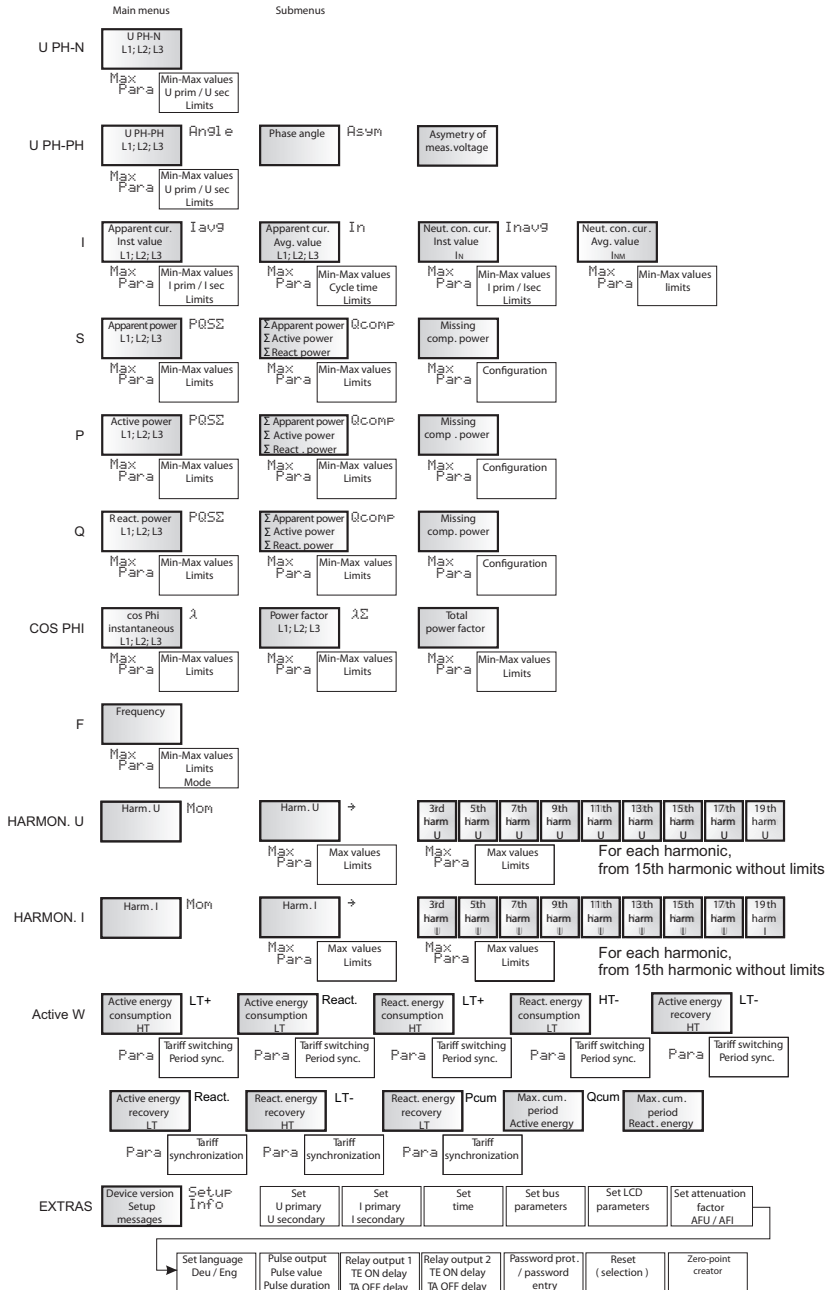

EDEKZA0019-4612-1\_DE-EN\_400

## 7 System operation

In this chapter, you will find instructions on how to operate the multimes 4F96 in daily use. Furthermore, you will find references to its complete range of functions.

### 7.1 Control and display panel

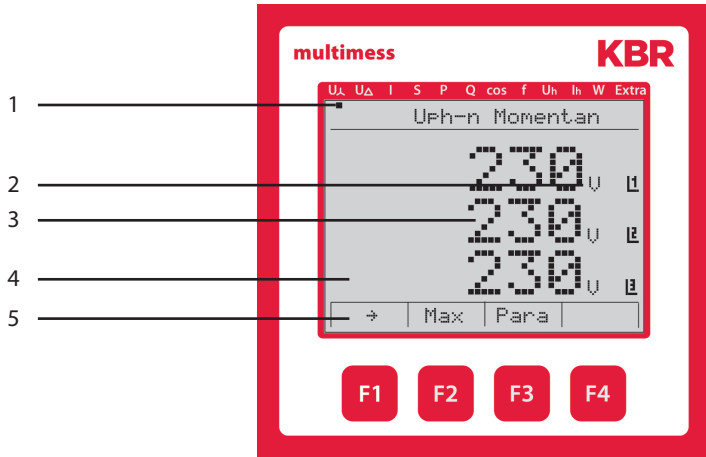

#### 7.1.1 Description of buttons and displays

##### 1 Display navigation panel

The navigation panel shows the main menu selected, considerably simplifying operation of the device. The operator can immediately see which menu he is in.

##### 2 Unit display

The DOT matrix display is normally used to show measured values. Each phase has its own display. In some submenus, this display area is used to show additional information to assist operation.

##### 3 Measuring range

These displays are used to represent measured, stored and programmed values. In some submenus, they are also used to simplify configuration with simple text output.

**4 Additional information area**

Additional information is conveyed with simple and self-explanatory icons. This additional information makes it easier for the operator to interpret the recorded values.

**5 Hot key area**

The text line corresponds to the button keys lying below it and is used to issue messages and text.

The interaction of button and accompanying display enables convenient and self-explanatory operation.

**7.1.2 Setting range**

Measuring voltage, primary	1 V to 9999 kV
Measuring voltage, secondary	100 V to 500 V
Measuring current, primary	1 A to 99.99 kA
Measuring current, secondary	1 A to 5 A
Limits	Depending on the configured transformer values
Current average time	1 to 15 minutes
Target Cos $\varphi$ for missing compensation power	Inductive 0.00 to capacitive 0.00
Main menu cos $\varphi$	Inductive 0.00 to capacitive 0.00
Frequency correction	Automatic - 50 Hz - 60 Hz
Limit values frequency	00.00 Hz to 70 Hz
Limits voltage harmonics	00.0% to 99.99%
Limits current harmonics	0 to 300 A
Attenuation coefficient voltage (display)	0 to 6
Attenuation coefficient current (display)	0 to 6
Working pulse output	Active and reactive energy 0.001 to 9990 pulses per KWH or kvar
Energy pulse duration	30 to 999 milliseconds
Signaling relay ON-delay	0 to 255 seconds
Signaling relay shutdown delay	0 to 255 seconds
Measuring period synchronization	Internal, KBR eBus, for tariff switching
Tariff switching	Internal, KBR eBus

# 8 Connection chart/terminal assignment

## 8.1 Connection chart

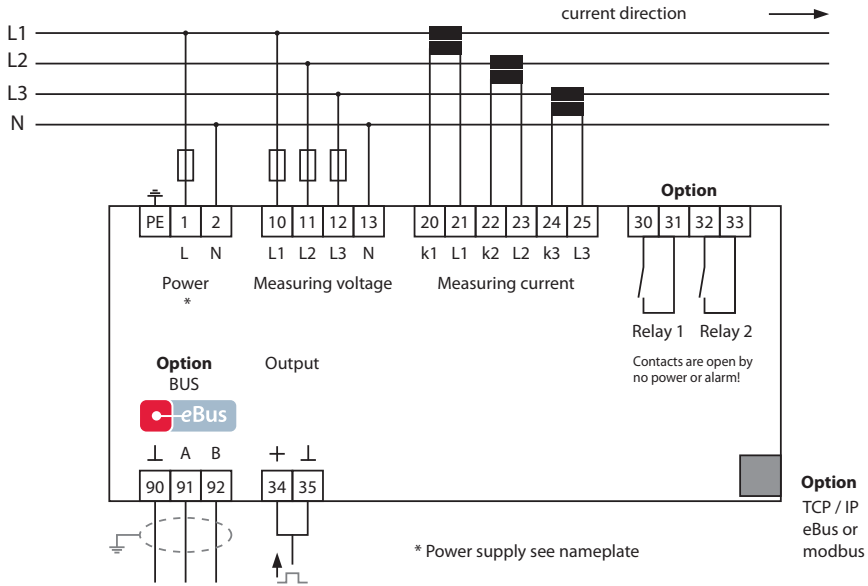

## 8.2 Terminal assignment

Terminal 1 (L) and 2 (N):

### Power supply connection

A control voltage is required to supply the device with power. The unit is equipped with a multi-range power supply and may be supplied by voltages of 85 – 265V AC/DC.

Terminal 10 (L1):

### Measuring input for voltage

11 (L2):

Three-phase voltage measurement in three-wire as well as four-wire rotary current networks. Direct measurement for 3x5...100...120V or 3x20...500...600V AC. Measuring intervals are configurable. Exceeding the measuring interval results in an error message. For higher voltages, the unit needs to be connected via a voltage transformer. For IT networks, a zero-point creator is required.

12 (L3):

13 (N):

- Terminal 20 (k1) and 21 (l1): **Measuring input for current**  
22 (k2) and 23 (l2)  
24 (k3) and 25 (l3)
- The measuring inputs for current must be connected via current transformers x/1A AC or x/5A AC.
- When connecting transformers, pay attention to the energy flow direction and the correct assignment of measuring voltage inputs to the current transformers.
- Terminals 30 and 31: **Floating relay contact relay 1**
- This contact serves as a message or alarm output. During operation, an audible or visual message may be activated, or a consumer shut down. The contact is open as long as the device is currentless, and if there is an active message. Maximum switching capacity of 2A at 250V AC.
- Terminals 32 and 33: **Floating relay contact relay 2**
- Refer to the description of the floating relay contact relay 1..
- Terminals 34 (+) and 35 (-): **Pulse output**
- Output of energy-proportional pulses via a digital contact (S0 interface in accordance with DIN 43864). Paying attention to the correct polarity is important for this output. The output signals can be processed by a maximum demand monitor or a master central process control, for example.
- Terminal 90 (earth): **Interface connection**  
91 (A)  
92 (B)
- For communication on the eBus or Modbus.

## 9. Technical data multimes 4F96

### 9.1 Measuring and display values

Wave form for U and I		Any
Voltage	Actual value of a measuring interval	Phase - 0: $U_{L1-N}; U_{L2-N}; U_{L3-N}$ / phase - phase: $U_{L1-2}; U_{L2-3}; U_{L3-1}$
	Units	[V, kV] display is switched automatically
	Measuring range	0.00kV to 999.9 kV
Current (apparent current)	Actual value of a measuring interval	$I_{L1\ inst}; I_{L2\ inst}; I_{L3\ inst}$ ; instantaneous value for each phase
	Average value determination	$I_{L1\ av}; I_{L2\ av}; I_{L3\ av}$ ; floating average value from RMS values over a programmable period of time
	Units	[A; kA; MA] display is switched automatically
	Measuring range	0.00A to 999.9 kA
Neutral conductor current	RMS value of a measuring interval	$I_{N\ inst} / I_{N\ av}$ instantaneous ("actual") and average value - cf. "Phase current"
	Units	[A; kA; MA, TA]; display is switched automatically
	Measuring range	0.00A to 1.2 MA
Frequency	Power frequency measurement	$f_{power}$
	Units	[Hz]
	Measuring range	40.....63 Hz
Apparent power	Calculation	$S_{L1}, S_{L2}, S_{L3}, S_{tot}$
	Units	[VA; kVA; MVA] display is switched automatically
	Measuring range	0.00VA to 999MVA
Active power	Calculation	$P_{L1}, P_{L2}, P_{L3}, P_{tot}$
	Units	[W; kW; MW] display is switched automatically
	Measuring range	0.00W to 999MW

Reactive power	Calculation -> ind. & cap.	$Q_{L1}, Q_{L2}, Q_{L3}, Q_{tot}$ ; distinction between ind./cap.
	Units	[Var; kvar; Mvar]; display is switched automatically
	Measuring range	0.00Var to 999Mvar
Power factor	Calculation -> ind. & cap.	$\cos\phi_{L1}; \cos\phi_{L2}; \cos\phi_{L3}; LF_{L1}; LF_{L2}; LF_{L3}; LF_{tot}$ ; distinction between ind./cap. $\cos\phi$ on the display
	Measuring range	CosPhi 0.1 ind. $\leftarrow 1 \rightarrow$ 0.1 cap., PF 0.1 - 1
Active energy	Calculation	W (HT/LT); $P_{average}$ max. of a measuring period
	Units	[Wh; kWh; MWh] display is switched automatically
	Measuring range	0.0kWh to 9999999999.9kWh
Reactive energy	Calculation	$W_{react}$ (HT/LT) ind. or cap. $Q_{average}$ max. of a measuring period
	Units	[varh; kvarh; Mvarh]; display is switched automatically
	Measuring range	0.0kvarh to 9999999999.9kvarh
Harmonics of the voltage	Distortion factor (THD) for voltage	Voltage: DF- $U_{L1}$ ; DF- $U_{L2}$ ; DF- $U_{L3}$ ;
	Partial distortion factors	3rd; 5th; 7th; 9th; 11th; 13th; 15th; 17th and 19th harmonic of the voltage
	Unit	[%]
	Measuring range	0.00% to 100%
Harmonics of the current	Current harmonics	3rd; 5th; 7th; 9th; 11th; 13th; 15th; 17th and 19th harmonic for each phase
	Total of current harmonics	Current: $I_{totL1}; I_{totL2}; I_{totL3}$ ; for each phase separately
	Unit	[A]
	Measuring range	0.00A to 999.9kA

## 9.2 Measuring accuracy

Current	$\pm 0.5 \% / \pm 1$ digit
Voltage	$\pm 0.5 \% / \pm 1$ digit
Apparent power	$\pm 1 \% / \pm 1$ digit
Active power	$\pm 1 \% / \pm 1$ digit
Reactive power	$\pm 1 \% / \pm 1$ digit
Power factor	$\pm 1 \% / \pm 1$ digit
Frequency	$\pm 0.1\text{Hz} / \pm 1$ digit

## 9.3 Measuring principle

Reading	64 values per period
A/D converter	10 Bit
Measuring U and I	Acquiring measuring values for U and I simultaneously
Updating speed (complete measuring cycle)	~ 500 ms
Calculation of harmonics	DFT with 256 points over four measuring periods
Frequency measurement	Mode: Voltage measured between phase L1, L2, L3 - N;

## 9.4 Device memory

Main and data memory	1MB RAM battery-buffered
Program and parameter memory	256 kB flash
Memory type	Ring buffer
Long-term memory (1 year)	Daily values for active and reactive energy (HT and LT)
Long-term memory for 160 / 80 / 40 days / 64 hours	60 / 30 / 15 / 1 minute – average values of: $P_{tot}$ ; $Q_{tot}$ ; adjustable via bus
Extreme values (max./min.)	Extreme values that occurred after connection to the power supply or after the extreme value memory has been deleted manually including date and time
Event memory: Memory size	4096 events including date and time they occurred



Limit violations: Time for acquisition	≥ 550 ms
Measuring voltage dips: Time for acquisition	≥ 20 ms; threshold can be set using the computer, value after reset 85% of rated voltage (according to EN 61000-4-30).
Measuring voltage: Time for acquisition	~ 500 ms
Battery life	Approx. 5 years acc. to manufacturer's specifications

### 9.5. Power supply

Power supply	85 to 265 V AC/DC; 15 VA; 50/60 Hz see nameplate
--------------	---

### 9.6. Hardware inputs and outputs

#### 9.6.1 Hardware inputs

Voltage measuring inputs	UL1-L2 ; UL2-L3 ; UL3-L1 ;	3 x 5V...100V...120V AC (measuring range 1) 3 x 20V... 500V...600V AC (measuring range 2)
	Input impedance	1.5 MOhm (Ph-Ph)
	Measuring range	Programmable
Current measuring input		3 x 0.01A...1A...1.2A AC (measuring range 1) 3 x 0.05A...5A...6A AC (measuring range 2)
	Power consumption	≤ 0.3VA per input at 6A
	Measuring range	Programmable

#### 9.6.2 Hardware outputs

Signaling relay for limit violations	Number	2 (option)
	Contact	Floating
	Reaction speed	Programmable
	Switching capacity	250V (AC) /2A
Pulse output	Output type	In proportion to active or reactive energy ➤ programmable on the device from 0.001 to 9990 Imp/kWh
	Optocoupler output	15 mA at max. 35V; 50 compatible
	Accuracy class	2
	Pulse duration	Programmable, min. 30 ms
	Power supply	External

EDEKZA0019-4612-1\_DE-EN\_400

Interface (option)	Bus	RS485 for connection to the eBus; max. 32 devices,
	Baud rate	38400
	Addressing	Can be addressed up to address 9999; automatically via software or manually on the device
	LAN	IEEE 802.3
	speed	10 Mbit / 100 Mbit
	Connection	IEEE 802.3, 10 base-T/100 base-Tx, cable CAT5

## 9.7 Electrical connection

Connection elements		Screw-type terminal
Permissible cross section of the connection lines		2.5 mm <sup>2</sup>
Measuring voltage inputs	Fuse protection	Max. 6 A
Measuring current inputs	Fuse protection	NONE!!! Always short-circuit current transformer terminals k and l prior to opening the circuit!
Input Control voltage	Fuse protection	Max. 6 A
Relay output	Fuse protection	Max 2A medium time-lag
BUS connection	Connection material	For proper operation, please only use shielded twisted-pair cables; e.g. I-Y-St-Y 2x2x0.8
Pulse output	Connection and cables	Ensure proper polarity! For proper operation, please only use shielded twisted-pair cables; e.g. I-Y-St-Y 2x2x0.8
Transformer connection	Connections	See connection chart
BUS connection	Pins for BUS connection via RS485	Terminal 90 (⊥) Terminal 91 (A) Terminal 92 (B)

### 9.8 Mechanical data

Flush-mounted device	Housing measurements	96 x 96 x 65 mm (H x W x D)
	Mounting cutout	92 x 92 mm
	Degree of protection	Front IP51 (with optionally available front door max. IP54), terminals IP20
	Weight	Min. 300g, max. 350g, depending on optional board

### 9.9 Standards and miscellaneous

Ambient conditions	Standards	DIN EN 60721-3-3/A2: 1997-07; 3K5+3Z11; (IEC721-3-3; 3K5+3Z11)
	Operating temperature	- 5°C ....+55°C
	Humidity	5% .....95% non-condensing
	Storage temperature	-25°C ....+70°C
	Operating altitude	0 .. 2000 m above sea level
Electrical safety	Standards	DIN EN 61010-1 2002-08 + correction 2002-11 + correction 2004-01
	Protection class	I
	Overvoltage category	CAT III:U <sub>PH-PH</sub> bis 400V CAT II:U <sub>PH-PH</sub> bis 600V
	Degree of protection	Front IP 51 (with optionally available front door max. IP 54) Terminals IP 20 improved mode of protection possible via additional seals on request; DIN EN 40050 part 9: 1993-05
Password protection	4 digit code	Deleting and programming parameters on the device is not enabled if password protection is active.
EMC	standard	DIN EN 61000-6-1 2007 DIN EN 61000-6-2 2005
Synchronization	Types	Internal, tariff switching or via eBus

EDEKZA0019-4612-1\_DE-EN\_400

## 9.10 Default settings after reset

Primary voltage / Secondary voltage	400 V
Primary current / Secondary current	5 A
Zero-point creator	off
Measuring period duration	15 minutes measuring period
Current average time	10 minutes
Target Cos $\varphi$ for missing compensation power	Inductive 0.98
Daylight saving time	From March to October
Frequency correction	Automatic
Tariff switching	Via KBR eBus
Low tariff time	Programmed time for internal switching of HT and LT: 22:00-6:00 (10pm to 6am)
Language	deut. (German text display)
Attenuation coefficient for current and voltage	dF 0 (no attenuation)
Energy pulse	P (active power for consumption), 1 pulse /kWh, pulse duration 100 ms
Alarm relay	On-delay tON = 0 sec Off-delay tOFF = 0 sec
Measuring period synchronization	Internal
Password	9999 / all functions can be accessed
Number of period entries in the load profile memory	4*3840 (for P+, P-, Q+, Q-)

### Unchanged by a RESET:

#### 1. Bus address

#### 2. Time

**ERKLÄRUNG DER KONFORMITÄT  
DECLARATION OF CONFORMITY  
DÉCLARATION DE CONFORMITÉ**

**Wir** KBR GmbH Schwabach  
We/Nous (Name des Anbieters / supplier's name / nom du fournisseur)

**Am Kieferschlag 7  
D-91126 Schwabach**

(Anschrift / address / adresse)

erklären in alleiniger Verantwortung, dass das (die) Produkt(e) /  
declare under our sole responsibility that the product(s) / Déclarons sous notre seule responsabilité, que le(s) produit(s)

**multimes 4F96 LCD ...**

(Bezeichnung, Typ oder Modell oder Seriennummer / name, type or model or serial number / nom, type ou modèle, N° de lot ou de série)

mit folgenden Europäischen Richtlinien übereinstimmt (übereinstimmen)  
is (are) in conformity with the following directives / Répondent(ent) aux directives suivantes

**Niederspannungsrichtlinie Nr.**  
Low Voltage Directive No.  
Directive Basse Tension N°

**EMV-Richtlinie Nr.**  
EMV Directive No.  
EMV Directive N°

**2006/95/EG**  
2006/95/EC  
2006/95/CE

**2004/108/EG**  
2004/108/EC  
2004/108/CE

Dies wird nachgewiesen durch die Einhaltung folgender Norm(en)  
This is documented by the accordance with the following standard(s) / Justifié par le respect de la (des) norme(s) suivante(s)

**DIN EN 61010-1-2002-08;**

**DIN EN 61010-1/B1:2002**

**DIN EN 61010-1/B2:2004**

**DIN EN 61000-6-1:2007**

**DIN EN 61000-6-2:2005**

**DIN EN 61000-6-3:2007**

**DIN EN 61000-6-4:2007**

(Titel und/oder Nr. sowie Ausgabedatum der Norm(en))  
Title and/or number and date of issue of the standard(s)  
Titre et/ou numéro et date d'édition de la (des) norme(s)



**Schwabach, 29.08.2011**

(Ort und Datum der Ausstellung)  
Place and date of issue  
Lieu et date de l'édition)



Geschäftsführer  
General manager

**KBR Kompensationsanlagenbau GmbH**

Am Kieferschlag 7  
D-91126 Schwabach

T +49 (0) 9122 6373 -0  
F +49 (0) 9122 6373 -83  
E [info@kbr.de](mailto:info@kbr.de)

[www.kbr.de](http://www.kbr.de)