

PRELIMINARY

Technical Information Manual

Revision n. 0

15 March 2010

MOD. DT5720
4 CHANNEL 12 BIT
250 MS/S DIGITIZER
MANUAL REV.0

NPO:
00100/09:5720x.MUTx/00

CAEN will repair or replace any product within the guarantee period if the Guarantor declares that the product is defective due to workmanship or materials and has not been caused by mishandling, negligence on behalf of the User, accident or any abnormal conditions or operations.

CAEN declines all responsibility for damages or injuries caused by an improper use of the Modules due to negligence on behalf of the User. It is strongly recommended to read thoroughly the CAEN User's Manual before any kind of operation.



CAEN reserves the right to change partially or entirely the contents of this Manual at any time and without giving any notice.

Disposal of the Product

The product must never be dumped in the Municipal Waste. Please check your local regulations for disposal of electronics products.



TABLE OF CONTENTS

1. GENERAL DESCRIPTION.....	7
1.1. OVERVIEW	7
1.2. BLOCK DIAGRAM.....	9
2. TECHNICAL SPECIFICATIONS.....	10
2.1. PACKAGING AND COMPLIANCY.....	10
2.2. POWER REQUIREMENTS	10
2.3. FRONT AND BACK PANEL.....	10
2.4. EXTERNAL CONNECTORS.....	11
2.4.1. ANALOG INPUT connectors.....	11
2.4.2. CONTROL connectors.....	11
2.4.3. ADC REFERENCE CLOCK connectors	11
2.4.4. Digital I/O connectors.....	11
2.4.5. Optical LINK connector	12
2.4.6. USB Port.....	12
2.4.7. 12V External.....	12
2.4.8. Spare Link.....	12
2.5. OTHER COMPONENTS	13
2.5.1. Displays.....	13
TECHNICAL SPECIFICATIONS TABLE	14
3. FUNCTIONAL DESCRIPTION.....	15
3.1. ANALOG INPUT.....	15
3.2. CLOCK DISTRIBUTION	15
3.2.1. Trigger Clock.....	16
3.3. ACQUISITION MODES	16
3.3.1. Acquisition run/stop.....	16
3.3.2. Acquisition Triggering: Samples and Events.....	16
3.3.2.1. Custom size events.....	18
3.3.3. Event structure.....	18
3.3.3.1. Header	18
3.3.3.2. Samples	18
3.3.3.3. Event format examples.....	19
3.4. ZERO SUPPRESSION	22
3.4.1. Zero Suppression Algorithm.....	22
3.4.1.1. Full Suppression based on the amplitude of the signal.....	22
3.4.1.2. Zero Length Encoding ZLE.....	22
3.4.2. Zero Suppression Examples.....	23
3.5. TRIGGER MANAGEMENT	27
3.5.1. External trigger	27

3.5.2.	Software trigger.....	27
3.5.3.	Local channel auto-trigger.....	27
3.5.3.1.	Trigger coincidence level.....	28
3.5.4.	Trigger distribution.....	29
3.6.	DATA TRANSFER CAPABILITIES.....	29
3.7.	EVENTS READOUT.....	30
3.8.	OPTICAL LINK AND USB ACCESS.....	30
3.8.1.	Software tools.....	31
4.	BOARD INTERNAL REGISTERS.....	32
4.1.	REGISTERS ADDRESS MAP.....	32
4.2.	CONFIGURATION ROM (0xF000-0xF088; R).....	33
4.3.	CHANNEL N ZS_THRES (0x1N24; R/W).....	34
4.4.	CHANNEL N ZS_NSAMP (0x1N28; R/W).....	34
4.5.	CHANNEL N THRESHOLD (0x1N80; R/W).....	34
4.6.	CHANNEL N OVER/UNDER THRESHOLD (0x1N84; R/W).....	34
4.7.	CHANNEL N STATUS (0x1N88; R).....	34
4.8.	CHANNEL N AMC FPGA FIRMWARE (0x1N8C; R).....	35
4.9.	CHANNEL N BUFFER OCCUPANCY (0x1N94; R).....	35
4.10.	CHANNEL N DAC (0x1N98; R/W).....	35
4.11.	CHANNEL N ADC CONFIGURATION (0x1N9C; R/W).....	35
4.12.	CHANNEL CONFIGURATION (0x8000; R/W).....	35
4.13.	CHANNEL CONFIGURATION BIT SET (0x8004; w).....	36
4.14.	CHANNEL CONFIGURATION BIT CLEAR (0x8008; w).....	36
4.15.	BUFFER ORGANIZATION (0x800C; R/W).....	36
4.16.	CUSTOM SIZE (0x8020; R/W).....	36
4.17.	ACQUISITION CONTROL (0x8100; R/W).....	36
4.18.	ACQUISITION STATUS (0x8104; R).....	37
4.19.	SOFTWARE TRIGGER (0x8108; w).....	37
4.20.	TRIGGER SOURCE ENABLE MASK (0x810C; R/W).....	37
4.21.	FRONT PANEL TRIGGER OUT ENABLE MASK (0x8110; R/W).....	38
4.22.	POST TRIGGER SETTING (0x8114; R/W).....	38
4.23.	FRONT PANEL I/O CONTROL (0x811C; R/W).....	39
4.24.	CHANNEL ENABLE MASK (0x8120; R/W).....	39
4.25.	ROC FPGA FIRMWARE REVISION (0x8124; R).....	39
4.26.	EVENT STORED (0x812C; R).....	39
4.27.	BOARD INFO (0x8140; R).....	39

4.28.	EVENT SIZE (0x814C; R).....	39
4.29.	CONTROL (0xEF00; R/W).....	40
4.30.	STATUS (0xEF04; R).....	40
4.31.	INTERRUPT STATUS ID (0xEF14; R/W).....	40
4.32.	INTERRUPT EVENT NUMBER (0xEF18; R/W).....	40
4.33.	BLOCK TRANSFER EVENT NUMBER (0xEF1C; R/W).....	40
4.34.	SCRATCH (0xEF20; R/W).....	40
4.35.	SOFTWARE RESET (0xEF24; W).....	41
4.36.	SOFTWARE CLEAR (0xEF28; W).....	41
4.37.	FLASH ENABLE (0xEF2C; R/W).....	41
4.38.	FLASH DATA (0xEF30; R/W).....	41
4.39.	CONFIGURATION RELOAD (0xEF34; W).....	41
5.	INSTALLATION	42
5.1.	POWER ON SEQUENCE	42
5.2.	POWER ON STATUS	42
5.3.	FIRMWARE UPGRADE.....	42

LIST OF FIGURES

FIG. 1.1:	MOD. D5720 DESKTOP WAVEFORM DIGITIZER	7
FIG. 1.1:	MOD. D5720 BLOCK DIAGRAM	9
FIG. 2.1:	MOD. DT5720 FRONT PANEL	10
FIG. 2.2:	MOD. DT5720 BACK PANEL.....	10
FIG. 2.3:	MCX CONNECTOR	11
FIG. 2.4:	AMP CLK IN CONNECTOR.....	11
FIG. 2.5:	LC OPTICAL CONNECTOR	12
FIG. 3.1:	INPUT DIAGRAM	15
FIG. 3.2:	CLOCK DISTRIBUTION DIAGRAM	15
FIG. 3.3:	TRIGGER OVERLAP	17
FIG. 3.4:	EVENT ORGANIZATION (STANDARD MODE), NORMAL FORMAT	19
FIG. 3.5:	EVENT ORGANIZATION (PACK2.5 MODE), NORMAL FORMAT	20
FIG. 3.6:	EVENT ORGANIZATION (STANDARD MODE), ZERO LENGTH ENCODING	20
FIG. 3.7:	EVENT ORGANIZATION (PACK2.5 MODE), ZERO LENGTH ENCODING	21
FIG. 3.8:	ZERO SUPPRESSION EXAMPLE.....	23
FIG. 3.9:	EXAMPLE WITH POSITIVE LOGIC AND NON-OVERLAPPING N_{LKB} / N_{LFW}	24

FIG. 3.10: EXAMPLE WITH NEGATIVE LOGIC AND NON-OVERLAPPING N_{LBK} / N_{LFW}	24
FIG. 3.11: EXAMPLE WITH POSITIVE LOGIC AND NON OVERLAPPING N_{LBK}	25
FIG. 3.12: EXAMPLE WITH POSITIVE LOGIC AND OVERLAPPING N_{LBK}	26
FIG. 3.13: BLOCK DIAGRAM OF TRIGGER MANAGEMENT.....	27
FIG. 3.14: LOCAL TRIGGER GENERATION.....	28
FIG. 3.15: LOCAL TRIGGER RELATIONSHIP WITH COINCIDENCE LEVEL.....	29
FIG. 3.16: EXAMPLE OF BLOCK TRANSFER READOUT.....	30
FIG. 3.17: OPTICAL LINK DAISY CHAIN	31

LIST OF TABLES

TABLE 1.1: AVAILABLE ITEMS	8
TABLE 2.2: FRONT PANEL LEDs	13
TABLE 2.3: MOD. DT5720 TECHNICAL SPECIFICATIONS	14
TABLE 3.1: BUFFER ORGANIZATION	17
TABLE 4.1: ADDRESS MAP FOR THE MODEL DT5720	32
TABLE 4.2: ROM ADDRESS MAP FOR THE MODEL DT5720	33

1. General description

1.1. Overview



Fig. 1.1: Mod. D5720 Desktop Waveform Digitizer

The Mod. DT5720 is a 4 Channel 12 bit 250 MS/s Desktop Waveform Digitizer with 2 Vpp dynamic range on single ended MCX coax. input connectors.

The 2 Channel version (Mod. DT5720A) is also available.

The DC offset adjustment ($\pm 1V$ range) on each channel by 16bit DACs allows a right sampling of a bipolar ($V_{in} = \pm 1V$) up to a full positive ($V_{in} = 0 \div +2V$) or negative ($V_{in} = 0 \div -2V$) analog input swing without losing dynamic resolution.

The module features a front panel clock In and a PLL for clock synthesis from internal/external references.

The data stream is continuously written in a circular memory buffer. When triggered, the FPGA writes further N samples for the post trigger and freezes the buffer that can be read via USB or optical link. The acquisition can continue dead-timeless in a new buffer.

Each channel has a SRAM memory buffer (1.25 M Samples/ch) divided in buffers of programmable size (1 - 1024). The readout (from USB or Optical link) of a frozen buffer is independent from the write operations in the active circular buffer (ADC data storage).

Zero suppression and data reduction algorithms allow substantial savings in data amount readout and processing, rejecting samples smaller than programmable thresholds.

DT5720 supports multi-board synchronization: an external reference clock can be distributed to all modules (CLK IN) and a common input (GPI) can be used to align all event trigger time tags

DT5720 houses USB 2.0 and optical link interfaces. USB 2.0 allows data transfers up to 30 MB/s. The Optical Link supports transfer rate of 80 MB/s, and offer daisy-chain capability. Therefore it is possible to connect up to 8 ADC modules to an A2818 Optical Link Controller or 32 modules to an A3818 (4 channel version).

CAEN provides also for this model a Digital Pulse Processing firmware for Physics Applications. This feature allows to perform on-line processing on detector signal directly

digitized. DT5720 is well suited for data acquisition and processing of signals from scintillators/photomultipliers or SiPM detectors, implementing function functionalities of a digital QDC.

Table 1.1: Available items

Code	Description
WDT5720AXAAA	DT5720A - 2 Ch. 12 bit 250 MS/s Digitizer: 1.25MS/ch, C4, SE
WDT5720XAAAA	DT5720 - 4 Ch. 12 bit 250 MS/s Digitizer: 1.25MS/ch, C4, SE
WA654XAAAAAA	A654 - Single Channel MCX to LEMO Cable Adapter
WA654K4AAAAAA	A654 KIT4 - 4 MCX TO LEMO Cable Adapter
WA2818XAAAAA	A2818 - PCI Optical Link
WA3818AXAAAA	A3818 - PCIe 1 Optical Link
WA3818BXAAAA	A3818 - PCIe 2 Optical Link
WA3818CXAAAA	A3818 - PCIe 4 Optical Link
WAI2730XAAAA	AI2730 - Optical Fibre 30 m. simplex
WAI2720XAAAA	AI2720 - Optical Fibre 20 m. simplex
WAI2705XAAAA	AI2705 - Optical Fibre 5 m. simplex
WAI2703XAAAA	AI2703 - Optical Fibre 30cm. simplex
WAY2730XAAAA	AY2730 - Optical Fibre 30 m. duplex
WAY2720XAAAA	AY2720 - Optical Fibre 20 m. duplex
WAY2705XAAAA	AY2705 - Optical Fibre 5 m. duplex
WFDPPPCI02AA	DPP CI Pack2 – Digital Pulse Processing with Charge Integration and Timing

1.2. Block Diagram

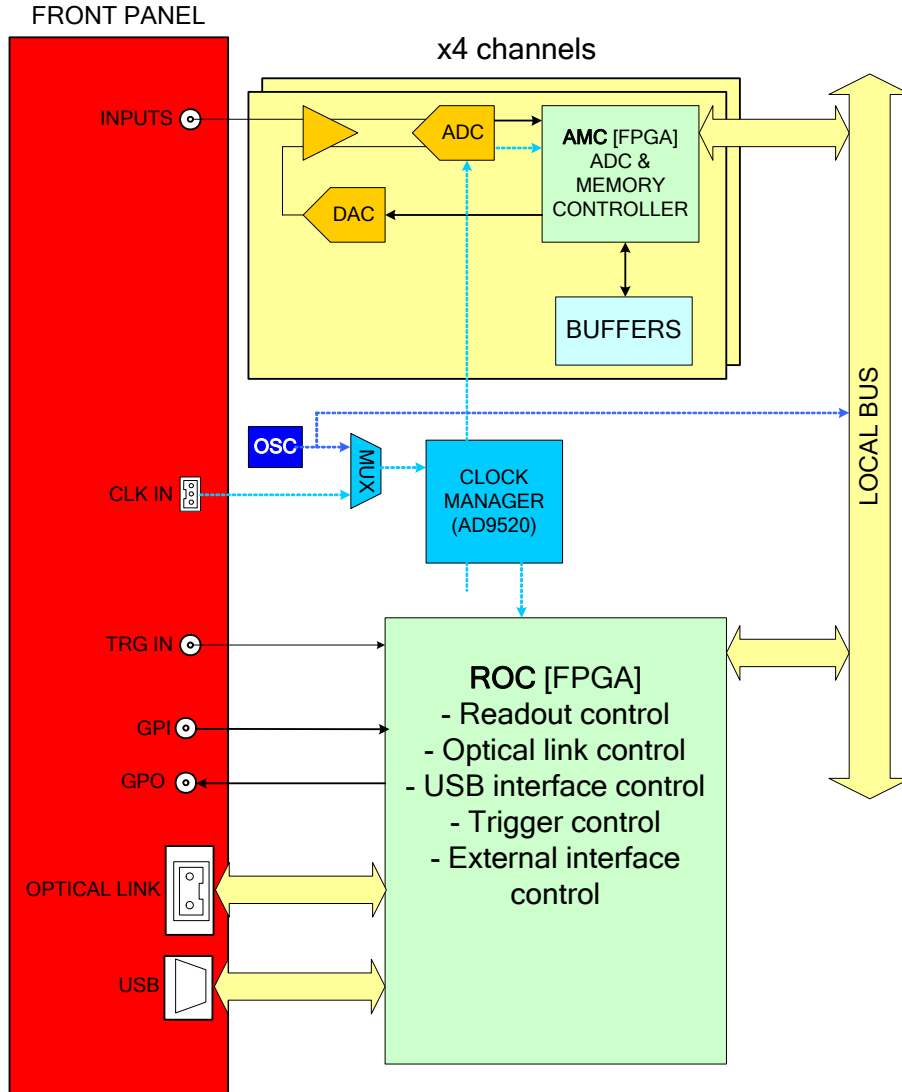

Fig. 1.1: Mod. D5720 Block Diagram

The function of each block will be explained in detail in the subsequent sections.

2. Technical specifications

2.1. Packaging and Compliancy

The unit is a Desktop module housed in a 154x50x164 mm³ alloy box.

2.2. Power requirements

The module is powered via the external AC/DC stabilized, 230Vac – 12Vdc, 1.4A power supply (Alpha Elettronica Nr: SW18-12-60 CDZ-Nr: 97894).

2.3. Front and Back Panel

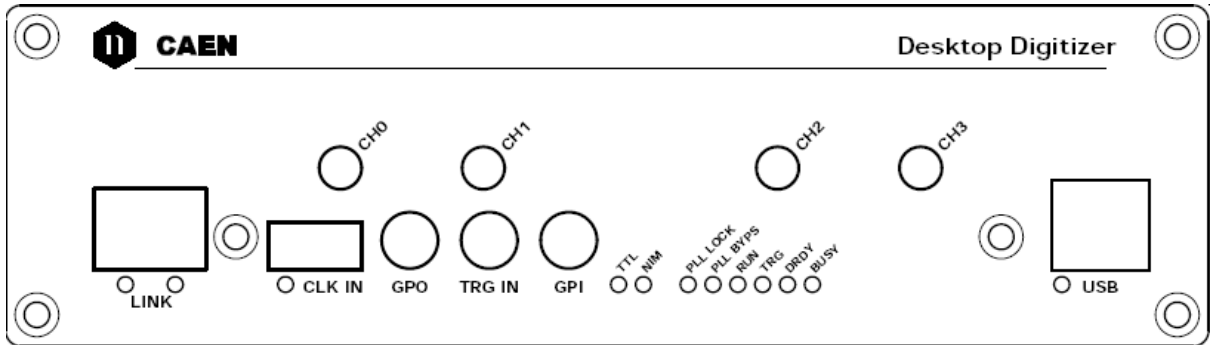

Fig. 2.1: Mod. DT5720 front panel

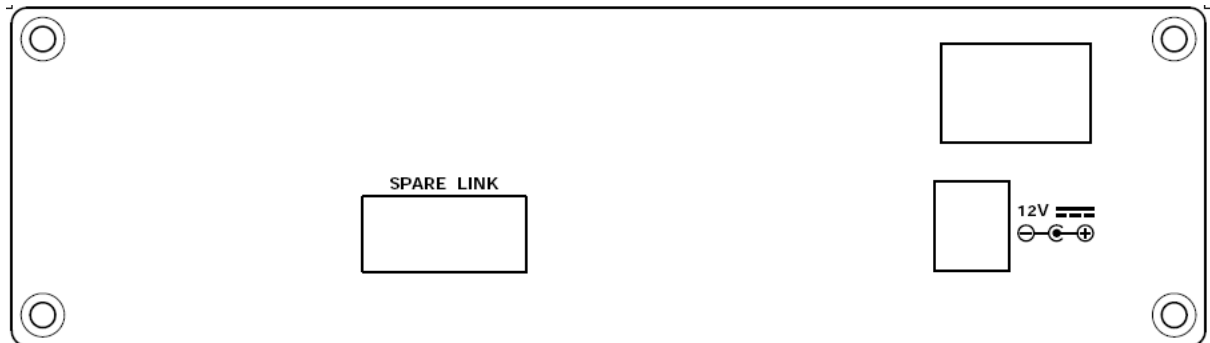

Fig. 2.2: Mod. DT5720 back panel

2.4. External connectors

2.4.1. ANALOG INPUT connectors



Fig. 2.3: MCX connector

Function:

Analog input, single ended, input dynamics: 2Vpp $Z_{in}=50\Omega$

Mechanical specifications:

MCX connector (CS 85MCX-50-0-16 SUHNER)

2.4.2. CONTROL connectors

Function:

TRG IN: External trigger input (NIM/TTL, $Z_{in}= 50\Omega$)

Mechanical specifications:

00-type LEMO connectors

2.4.3. ADC REFERENCE CLOCK connectors

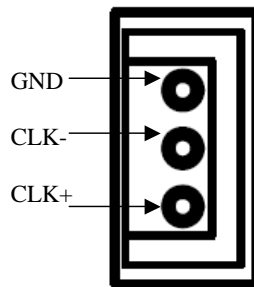

Fig. 2.4: AMP CLK IN Connector

Function:

CLK IN: External clock/Reference input, AC coupled (diff. LVDS, ECL, PECL, LVPECL, CML), $Z_{diff}= 110\Omega$.

Mechanical specifications:

AMP 3-102203-4 AMP MODUII

2.4.4. Digital I/O connectors

Function:

- GPI: programmable front panel input (NIM/TTL, $Z_{in}=50\Omega$)

- GPO: programmable front panel output (NIM/TTL, $Z_{in}=50\Omega$); used as output for trigger propagation

Mechanical specifications:
00-type LEMO connectors

2.4.5. Optical LINK connector

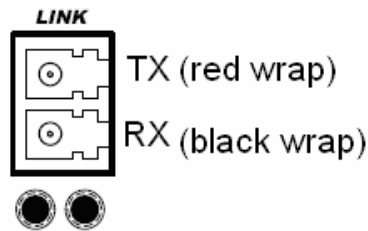

Fig. 2.5: LC Optical Connector

Mechanical specifications:

LC type connector; to be used with Multimode 62.5/125 μ m cable with LC connectors on both sides

Electrical specifications:

Optical link for data readout and slow control with transfer rate up to 80MB/s; daisy chainable.

2.4.6. USB Port

Mechanical specifications:

B type USB connector

Electrical specifications:

USB 2.0 and USB 1.1 compliant

2.4.7. 12V External

Mechanical specifications:

RAPC722X SWITCHCRAFT PCB DC Power Jack

Electrical specifications:

+12V DC Input

2.4.8. Spare Link

Mechanical specifications:

3M-7610-5002 connector

2.5. Other components

2.5.1. Displays

The front panel hosts the following LEDs:

Table 2.2: Front panel LEDs

Name:	Colour:	Function:
CLK_IN	green	External clock enabled.
NIM	green	Standard selection for CLK, GPO, TRG IN, GPI.
TTL	green	Standard selection for CLK, GPO, TRG IN, GPI.
USB	green	Data transfer activity
LINK	green/yellow	Network present; Data transfer activity
PLL_LOCK	green	The PLL is locked to the reference clock
PLL_BYPS	green	The reference clock drives directly ADC clocks; the PLL circuit is switched off and the PLL_LOCK LED is turned off.
RUN	green	RUN bit set (see § 4.18)
TRG	green	Triggers are accepted
DRDY	green	Event/data (depending on acquisition mode) are present in the Output Buffer
BUSY	red	All the buffers are full

Technical specifications table

Table 2.3: Mod. DT5720 technical specifications

Packaging	Desktop module; 154x50x164 mm ³ (WxHxD), Weight: 680 gr
Analog Input	4 channels (MCX 50 Ohm) Single-ended Input range: 2 Vpp; Bandwidth: 125 MHz. Programmable DAC for Offset Adjust x ch., adjustment range: $\pm 1V$
Digital Conversion	Resolution: 12 bit; Sampling rate: 10 to 250 MS/s simultaneously on each channel
ADC Sampling Clock generation	Three operating modes: - PLL mode - internal reference (50 MHz loc. oscillator). - PLL mode - external reference on CLK_IN (Jitter<100ppm). - PLL Bypass mode: Ext. clock on CLK_IN drives directly ADC clocks (Freq.: 10 ÷ 250 MHz).
Digital I/O	CLK_IN (AMP Modu II): - AC coupled differential input clock LVDS, ECL, PECL, LVPECL, CML (single ended NIM/TTL available) - Jitter<100ppm TRG_IN (LEMO 50 Ohm, NIM/TTL) GPI/GPO (LEMO 50 Ohm, NIM/TTL)
Memory Buffer	1.25 M sample/ch Multi Event Buffer Programmable event size and pre-post trigger. Divisible into 1 ÷ 1024 buffers. Readout of Frozen buffer independent from write operations in the active buffer (ADC data storage).
Trigger	Common Trigger - TRG_IN (External signal) - Software (from USB or Optical Link) - Self trigger (Internal threshold auto-trigger) Daisy chain trigger propagation among boards (using GPO)
Trigger Time Stamp	32bit – 8ns (34s range)
Multi Modules Synchronization	Allows data alignment and consistency across multiple DT5720 modules: - CLK_IN allows the synchronization to a common clock source - GPI ensures Trigger time stamps and start acquisition times alignment
USB interface	USB2.0 and USB1.1 compliant Up to 30 MB/s transfer rate
Optical Link	CAEN proprietary protocol, up to 80 MB/s transfer rate, with Optical Link Controller (Mod. A2818/A3818).
Upgrade	Firmware can be upgraded via Optical Link or USB interface
Software	General purpose C and LabView Libraries Demo and Software Tools for Windows and Linux
Electrical Power	Voltage range: 12 \pm 10% Vdc

3. Functional description

3.1. Analog Input

Input dynamics is 2V ($Z_{in} = 50 \Omega$). A 16bit DAC allows to add a DC offset to the signal in the ± 1 V range.
The input bandwidth ranges from DC to 125 MHz (with 1st order anti-aliasing low pass filter).

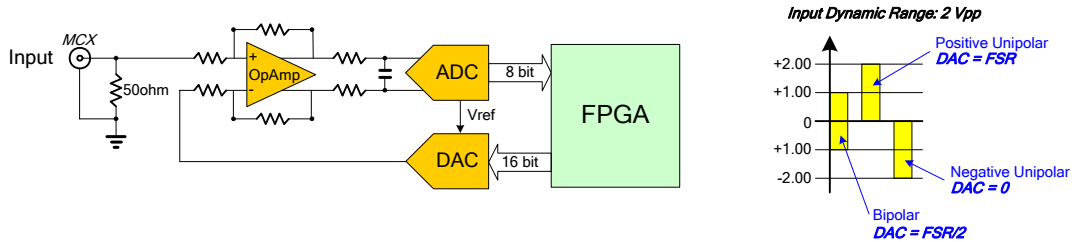

Fig. 3.1: Input diagram

3.2. Clock Distribution

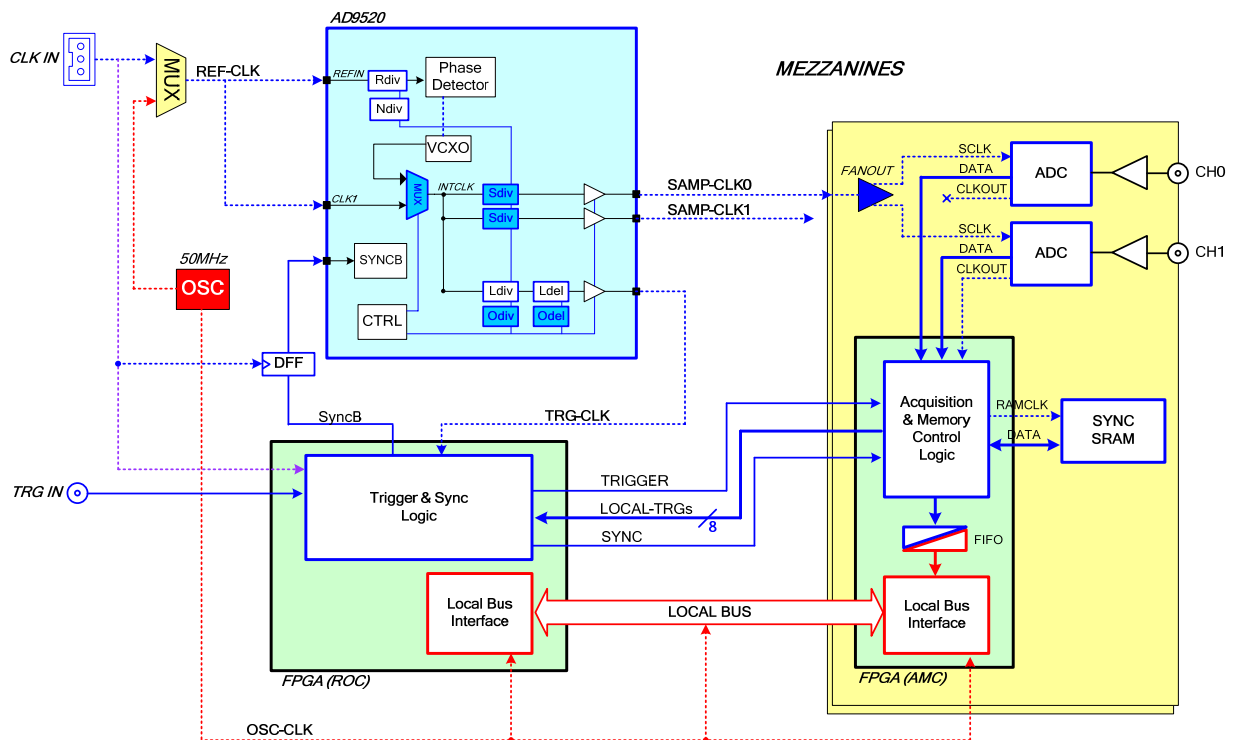

Fig. 3.2: Clock distribution diagram

The module clock distribution takes place on two domains: OSC-CLK and REF-CLK; the former is a fixed 50MHz clock provided by an on board oscillator, the latter provides the ADC sampling clock.

OSC-CLK handles Local Bus (communication between motherboard and mezzanine boards; see red traces in the figure above).

REF-CLK handles ADC sampling, trigger logic, acquisition logic (samples storage into RAM, buffer freezing on trigger) through a clock chain. Such domain can use either an external (via front panel signal) or an internal (via local oscillator) source, in the latter case OSC-CLK and REF-CLK will be synchronous (the operation mode remains the same anyway).

DT5720 uses an integrated phase-locked-loop (PLL) and clock distribution device (AD9520). It is used to generate the sampling clock for ADCs (SAMP-CLK0/SAMP-CLK1) and trigger logic synchronization clock (TRG-CLK).

Both clocks can be generated from the internal oscillator or from external clock input (CLK IN). By default, board uses the internal clock as PLL reference (REF-CLK). External clock can be selected by register access. AD9520 configuration can be changed and stored into non-volatile memory. AD9520 configuration change is primarily intended to be used for external PLL reference clock frequency change:

DT5720 locks to an external 50 MHz clock with default AD9520 configuration.

Please contact CAEN (support.frontend@caen.it) for more information and configuration tools.

Refer also to AD9520 data sheet for more details:

http://www.analog.com/UploadedFiles/Data_Sheets/AD9520.pdf

3.2.1. Trigger Clock

TRG-CLK signal has a frequency equal to $\frac{1}{2}$ of SAMP-CLK; therefore a 2 samples "uncertainty" occurs over the acquisition window.

3.3. Acquisition Modes

3.3.1. Acquisition run/stop

The acquisition can be started in two ways, according to Acquisition Control register bit 0 setting (see § 4.17):

- setting the RUN/STOP bit (bit 2) in the Acquisition Control register (bit 0 of Acquisition Control must be set to REGISTER-CONTROLLED RUN MODE)
- driving GPI signal high (bit 0 of Acquisition Control must be set to 1, GPI CONTROLLED RUN MODE)

Subsequently acquisition is stopped either:

- resetting the RUN/STOP bit (bit 2) in the Acquisition Control register (bit 0 of Acquisition Control must be set to REGISTER-CONTROLLED RUN MODE)
- driving GPI signal low (bit 0 of Acquisition Control set to 1, GPI CONTROLLED RUN MODE)

3.3.2. Acquisition Triggering: Samples and Events

When the acquisition is running, a trigger signal allows to:

- store a Trigger Time Tag (TTT): the value of a 32 bit counter which steps on with 125MHz frequency and represents a time reference
- increment the EVENT COUNTER (see § 4.26)

- fill the active buffer with the pre/post-trigger samples, whose number is programmable (Acquisition window width, § 4.22), freezing then the buffer for readout purposes, while acquisition continues on another buffer

Table 3.1: Buffer Organization

REGISTER (see § 4.15)	BUFFER NUMBER	SRAM 1.25 MB/ch	
		Std.	Pack2.5
0x00	1	1M	1.25M
0x01	2	512K	640K
0x02	4	256K	320K
0x03	8	128K	160K
0x04	16	64K	80K
0x05	32	32K	40K
0x06	64	16K	20K
0x07	128	8K	10K
0x08	256	4K	5K
0x09	512	2K	2.5K
0x0A	1024	1K	1.25K

An event is therefore composed by the trigger time tag, pre- and post-trigger samples and the event counter.

Overlap between “acquisition windows” may occur (a new trigger occurs while the board is still storing the samples related to the previous trigger); this overlap can be either rejected or accepted (programmable via software).

If the board is programmed to accept the overlapped triggers, as the “overlapping” trigger arrives, the current active buffer is filled up, then the samples storage continues on the subsequent one.

In this case events will not have all the same size (see figure below).

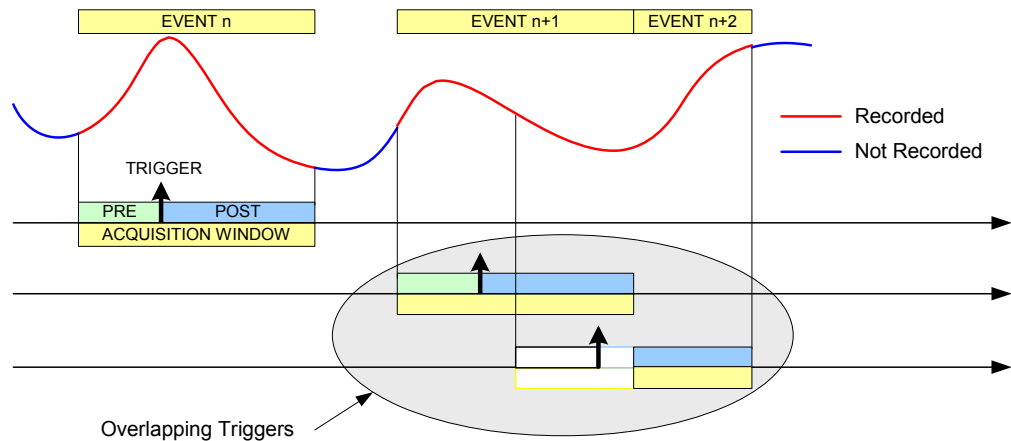

Fig. 3.3: Trigger Overlap

A trigger can be refused for the following causes:

- acquisition is not active
- memory is FULL and therefore there are no available buffers

- the required number of samples for building the pre-trigger of the event is not reached yet; this happens typically as the trigger occurs too early either with respect to the RUN_ACQUISITION command (see § 3.3.1) or with respect to a buffer emptying after a MEMORY_FULL status
- the trigger overlaps the previous one and the board is not enabled for accepting overlapped triggers

As a trigger is refused, the current buffer is not frozen and the acquisition continues writing on it. The Event Counter can be programmed in order to be either incremented or not. If this function is enabled, the Event Counter value identifies the number of the triggers sent (but the event number sequence is lost); if the function is not enabled, the Event Counter value coincides with the sequence of buffers saved and readout.

3.3.2.1. Custom size events

It is possible to make events with a number of Memory locations, which depends on Buffer Organization register setting (see § 4.15) smaller than the default value. One memory location contains two ADC samples and the maximum number of memory locations N_{LOC} is therefore half the maximum number of samples per block $NS = 512K/Nblocks$ ($640K/Nblocks$ when Pack2.5 mode is used).

Smaller N_{LOC} values can be achieved by writing the number of locations N_{LOC} into the Custom Size register (see § 4.16).

$N_{LOC} = 0$ means "default size events", i.e. the number of memory locations is the maximum allowed.

$N_{LOC} = N1$, with the constraint $0 < N1 < \frac{1}{2}NS$ ($0 < N1 < \frac{2}{5}NS$ with Pack2.5), means that one event will be made of $2 \cdot N1$ samples ($2.5 \cdot N1$ samples with Pack2.5).

3.3.3. Event structure

An event is structured as follows:

- Header (4 32-bit words)
- Data (variable size and format)

The event can be readout via Optical Link; data format is 32 bit long word, therefore each long_word contains 4 samples.

3.3.3.1. Header

It is composed by four words, namely:

- Size of the event (number of 32 bit long words)
- Bit24; data format: 0= normal format; 1= *Zero Length Encoding* data compression method enabled; Channel Mask (=1: channels participating to event; ex CH2 and CH3 participating → Ch Mask: 0xC, this information must be used by the software to acknowledge which channel the samples are coming from)
- Event Counter: It is the trigger counter; it can count either accepted triggers only, or all triggers (see § 4.16).
- Trigger Time Tag: It is a 32 bit counter (31 bit count + 1 overflow bit), which is reset as acquisition starts and is incremented at each sampling clock hit. It is the trigger time reference.

3.3.3.2. Samples

Stored samples; data from masked channels are not read.

3.3.3.3. Event format examples

The event format is shown in the following figure (case of 4 channels enabled, with *Zero Length Encoding* disabled and enabled respectively; see § 3.3.3.1 and § 3.4.1.2):

An event is structured as follows:

- identifier (Trigger Time Tag, Event Counter)
- samples caught in the acquisition windows

The event can be stored in the board memories (and can be readout via Optical Link) in two ways: data format is 32 bit long word, and each long_word may contain 2 samples (Standard mode) or “two and a half” (Pack2.5 mode), depending on Channel Configuration register setting (see § 4.12).

The event format is therefore one of the following:

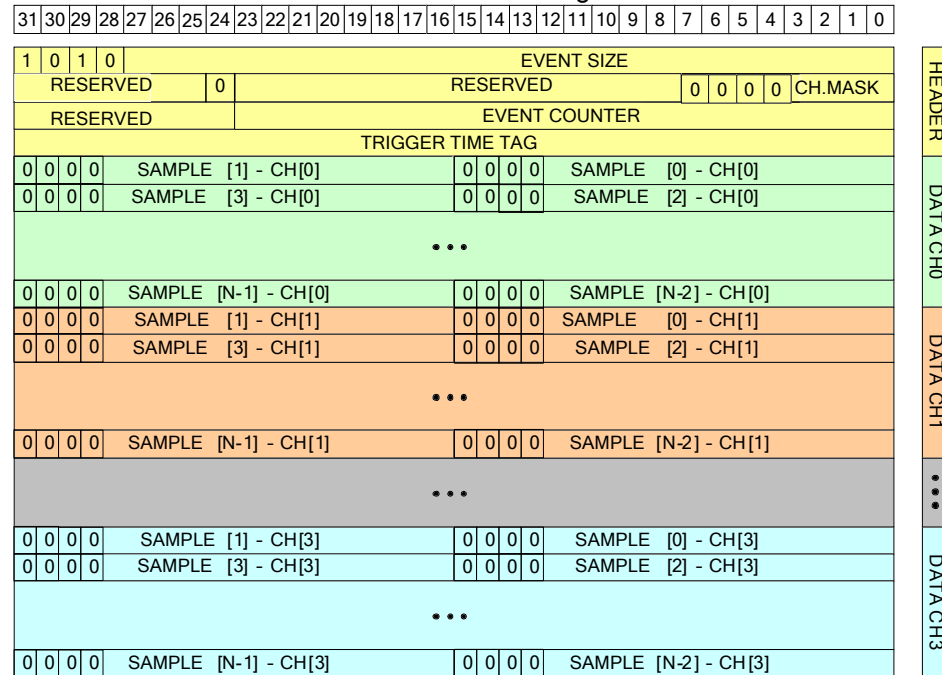

Fig. 3.4: Event Organization (standard mode), normal format

31	30	29	28	27	26	25	24	23	22	21	20	19	18	17	16	15	14	13	12	11	10	9	8	7	6	5	4	3	2	1	0
1 0 1 0				EVENT SIZE																											
RESERVED				0																RESERVED				0 0 0 0				CH.MASK			
RESERVED				EVENT COUNTER																											
TRIGGER TIME TAG																															
0 0		S [2] - CH[0] L				S [1] - CH[0] H				S [1] - CH[0] L				S [0] - CH[0] H				S [0] - CH[0] L													
0 0		S [4] - CH[0] H				S [4] - CH[0] L				S [3] - CH[0] H				S [3] - CH[0] L				S [2] - CH[0] H													
...																															
0 0		S [N] - CH[0] H				S [N] - CH[0] L				S [N-1] - CH[0] H				S [N-1] - CH[0] L				S [N-2] - CH[0] H													
0 0		S [2] - CH[1] L				S [1] - CH[1] H				S [1] - CH[1] L				S [0] - CH[1] H				S [0] - CH[1] L													
0 0		S [4] - CH[1] H				S [4] - CH[1] L				S [3] - CH[1] H				S [3] - CH[1] L				S [2] - CH[1] H													
...																															
0 0		S [N] - CH[1] H				S [N] - CH[1] L				S [N-1] - CH[1] H				S [N-1] - CH[1] L				S [N-2] - CH[1] H													
...																															
0 0		S [2] - CH[3] L				S [1] - CH[3] H				S [1] - CH[3] L				S [0] - CH[3] H				S [0] - CH[3] L													
0 0		S [4] - CH[3] H				S [4] - CH[3] L				S [3] - CH[3] H				S [3] - CH[3] L				S [2] - CH[3] H													
...																															
0 0		S [N] - CH[3] H				S [N] - CH[3] L				S [N-1] - CH[3] H				S [N-1] - CH[3] L				S [N-2] - CH[3] H													

Fig. 3.5: Event Organization (Pack2.5 mode), normal format

31	30	29	28	27	26	25	24	23	22	21	20	19	18	17	16	15	14	13	12	11	10	9	8	7	6	5	4	3	2	1	0
1 0 1 0				EVENT SIZE																											
RESERVED				1																RESERVED				0 0 0 0				CH. MASK			
RESERVED				EVENT COUNTER																											
TRIGGER TIME TAG																															
SIZE																															
CONTROL WORD																															
0 0		0 0		SAMPLE [1] - CH[0]				0 0 0 0				SAMPLE [0] - CH[0]																			
...																															
CONTROL WORD																															
0 0		0 0		SAMPLE [N-1] - CH[0]				0 0				SAMPLE [N-2] - CH[0]																			
SIZE																															
CONTROL WORD																															
0 0		0 0		SAMPLE [1] - CH[1]				0 0 0 0				SAMPLE [0] - CH[1]																			
...																															
CONTROL WORD																															
0 0		0 0		SAMPLE [N-1] - CH[1]				0 0 0 0				SAMPLE [N-2] - CH[1]																			
...																															
SIZE																															
CONTROL WORD																															
0 0		0 0		SAMPLE [1] - CH[3]				0 0 0 0				SAMPLE [0] - CH[3]																			
...																															
CONTROL WORD																															
0 0		0 0		SAMPLE [N-1] - CH[3]				0 0 0 0				SAMPLE [N-2] - CH[3]																			

Fig. 3.6: Event Organization (standard mode), Zero Length Encoding

31	30	29	28	27	26	25	24	23	22	21	20	19	18	17	16	15	14	13	12	11	10	9	8	7	6	5	4	3	2	1	0			
1		0		1		0		EVENT SIZE																				HEADER						
RESERVED						1	RESERVED														0				0	0	0		0	CHANNEL MASK				
RESERVED						EVENT COUNTER																												
TRIGGER TIME TAG																																		
SIZE																												DATA CHANNEL 0						
CONTROL WORD																																		
0		0		S(2) - CH(0) L				S(1) - CH(0) H				S(1) - CH(0) L				S(0) - CH(0) H				S(0) - CH(0) L														
0		0		S(4) - CH(0) H				S(4) - CH(0) L				S(3) - CH(0) H				S(3) - CH(0) L				S(2) - CH(0) H														
.....																																		
CONTROL WORD																																		
0		0		S(N-2) - CH(0) L				S(N-3) - CH(0) H				S(N-3) - CH(0) L				S(N-4) - CH(0) H				S(N-4) - CH(0) L														
0		0		S(N) - CH(0) H				S(N) - CH(0) L				S(N-1) - CH(0) H				S(N-1) - CH(0) L				S(N-2) - CH(0) H														
SIZE																													DATA CHANNEL 1					
CONTROL WORD																																		
0		0		S(2) - CH(1) L				S(1) - CH(1) H				S(1) - CH(1) L				S(0) - CH(1) H				S(0) - CH(1) L														
0		0		S(4) - CH(1) H				S(4) - CH(1) L				S(3) - CH(1) H				S(3) - CH(1) L				S(2) - CH(1) H														
.....																																		
CONTROL WORD																																		
0		0		S(N-2) - CH(1) L				S(N-3) - CH(1) H				S(N-3) - CH(1) L				S(N-4) - CH(1) H				S(N-4) - CH(1) L														
0		0		S(N) - CH(1) H				S(N) - CH(1) L				S(N-1) - CH(1) H				S(N-1) - CH(1) L				S(N-2) - CH(1) H														
.....																												DATA CHANNEL 3						
SIZE																																		
CONTROL WORD																																		
0		0		S(2) - CH(3) L				S(1) - CH(3) H				S(1) - CH(3) L				S(0) - CH(3) H				S(0) - CH(3) L														
0		0		S(4) - CH(3) H				S(4) - CH(3) L				S(3) - CH(7) H				S(3) - CH(7) L				S(2) - CH(3) H														
.....																																		
CONTROL WORD																																		
0		0		S(N-2) - CH(3) L				S(N-3) - CH(3) H				S(N-3) - CH(3) L				S(N-4) - CH(3) H				S(N-4) - CH(3) L														
0		0		S(N) - CH(3) H				S(N) - CH(3) L				S(N-1) - CH(3) H				S(N-1) - CH(3) L				S(N-2) - CH(3) H														

Fig. 3.7: Event Organization (Pack2.5 mode), Zero Length Encoding

3.4. Zero suppression

The board implements two algorithms of “Zero Suppression” and “Data Reduction”¹

- Full Suppression based on the signal amplitude (ZS_AMP),
- Zero Length Encoding (ZLE),

The algorithm to be used is selected via Control register, and its configuration takes place via two more registers (CHANNEL n ZS_THRES and CHANNEL n ZS_NSAMP). When using these algorithms, it must be noticed that that one datum (64bit long word) contains 4 samples (5 samples with Pack2.5 mode): therefore, depending also on trigger polarity (settings of bit31 of Channel n ZS_THRES register), threshold is crossed if:

- Positive Logic: one datum is considered **OVER** threshold if at least one sample is higher or equal to threshold.
- Negative Logic: one datum is considered **UNDER** threshold if at least one sample is lower than threshold.

3.4.1. Zero Suppression Algorithm

3.4.1.1. Full Suppression based on the amplitude of the signal

Full Suppression based on the signal amplitude allows to discard a full event if the signal does not exceed the programmed threshold for N_s subsequent data at least (N_s is programmable, see § 4.4).

It is also possible to configure the algorithm with “negative” logic: in this case the event is discarded if the signal does not remain under the programmed threshold for N_s subsequent data at least.

3.4.1.2. Zero Length Encoding ZLE

Zero Length Encoding allows to transfer the event in compressed mode, discarding either the data under the threshold set by the User (positive logic) or the data over the threshold set by the User (negative logic).

With Zero Length Encoding it is also possible to set N_{LBK} (LOOK BACK), the number of data to be stored before the signal crosses the threshold and/or, N_{LFD} (LOOK FORWARD), the number of data to be stored after the signal crosses the threshold (see § 4.3).

In this case the event of each channel has a particular format which allows the construction of the acquired time interval:

- **Total size of the event (total number of transferred 32bit data words)**
- **Control word**
- [stored valid data, if control word is “good”]
- **Control word**
- [stored valid data, if control word is “good”]
- ...

The total size is the number of 32 bit data that compose the event (including the size itself).

The control word has the following format:

¹ Available with Piggy Back Rev. 0.5 and Firmware Rev. 0.5

Bit	Function
[31]	0: skip 1: good
[30]	0: AMC FPGA FW rev 0.5 and earlier 1: AMC FPGA FW rev 0.6 and later
[29:21]	0
[20:0]	stored/skipped words

If the control word type is “good”, then it will be followed by as many 32bit data words as those indicated in the “stored/skipped words” field; if the control word type is “skip” then it will be followed by a “good” control word, unless the end of event is reached.

IMPORTANT NOTE: the maximum allowed number of control words is 62 (14 for AMC FPGA release 0.5 and earlier); therefore the ZLE is active within the event until the 14th transition between a “good” and a “skip” zone (or between a “skip” and a “good” zone). All the subsequent samples are considered “good” and stored.

3.4.2. Zero Suppression Examples

If the input signal is the following ($N_1, N_2 \dots N_n, N_{LBK}, N_{LFWD}$ are 64bit longwords = 4 samples each²):

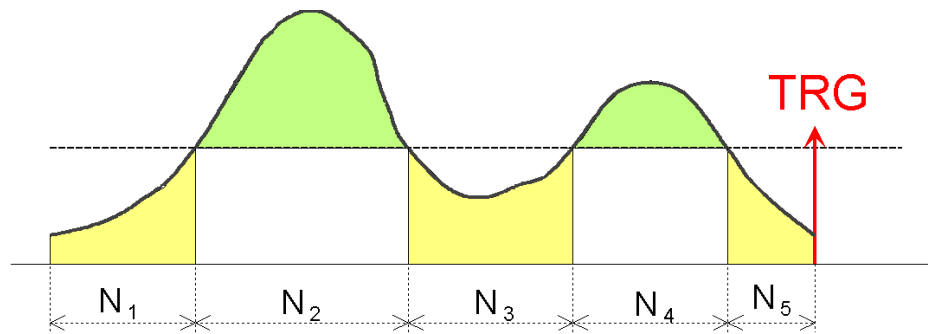

Fig. 3.8: Zero Suppression example

If the algorithm works in positive logic, and

- $N_{LBK} < N_1$;
- $N_{LFWD} < N_5$;
- $N_{LBK} + N_{LFWD} < N_3$;

² 5 samples each with Pack2.5 mode

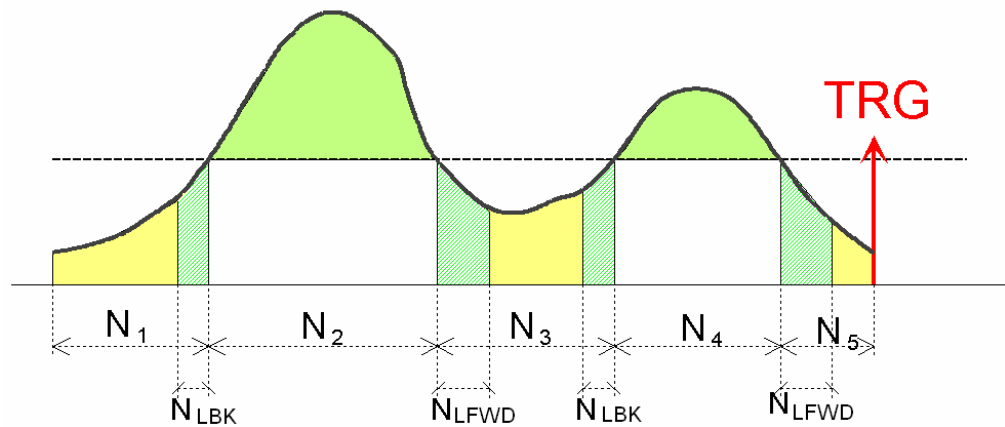

Fig. 3.9: Example with positive logic and non-overlapping N_{LBK} / N_{LFWD}

then the readout event is:

$N'_2 + N'_4 + 5$ (control words) + 1 (size)

Skip $N'_1 = 2(N_1 - N_{LBK})$

Good $N'_2 = 2(N_{LBK} + N_2 + N_{LFWD})$

... N'_2 words with samples over threshold

Skip $N'_3 = 2(N_3 - N_{LFWD} - N_{LBK})$

Good $N'_4 = 2(N_{LBK} + N_4 + N_{LFWD})$

... N'_4 words with samples over threshold

Skip $N'_5 = 2(N_5 - N_{LFWD})$

If the algorithm works in negative logic, and

$N_{LBK} + N_{LFWD} < N_2$;

$N_{LBK} + N_{LFWD} < N_4$;

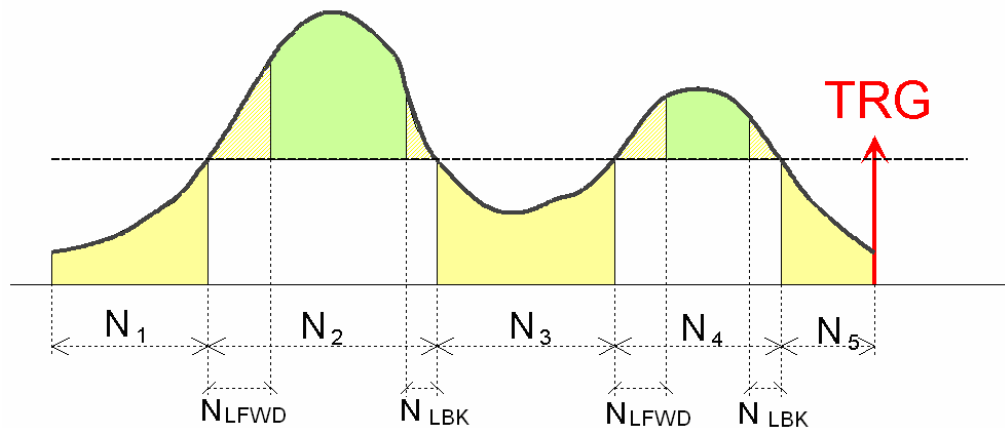

Fig. 3.10: Example with negative logic and non-overlapping N_{LBK} / N_{LFWD}

then the readout event is:

$N'_1 + N'_3 + N'_5 + 5$ (control words) + 1 (size)

Good $N'_1 = 2(N_1 + N_{LFWD})$

... N'_1 words with samples under threshold

Skip $N'_2 = 2(N_2 - N_{LFWD} - N_{LBK})$

Good $N'_3 = 2(N_{LBK} + N_3 + N_{LFWD})$

... N'_3 words with samples under threshold

Skip $N'_4 = 2(N_4 - N_{LFWD} - N_{LBK})$
 Good $N'_5 = 2(N_{LBK} + N_5)$
 ... N'_5 words with samples under threshold

In some cases the number of data to be discarded can be smaller than N_{LBK} and N_{LFWD} :

- 1) If the algorithm works in positive logic, and
 $N_1 \leq N_{LBK} < N_3$;
 $N_{LFWD} = 0$;

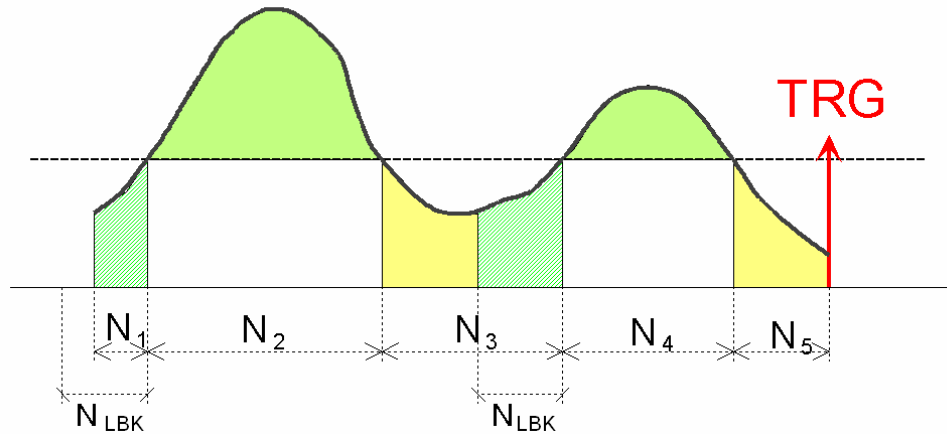

Fig. 3.11: Example with positive logic and non overlapping N_{LBK}

then the readout event is:
 $N'_1 + N'_2 + N'_4 + 5$ (control words) + 1 (size)
 Good $N'_1 + N'_2 = 2(N_1 + N_2)$
 ... $N'_1 + N'_2$ words with samples over threshold
 Skip $N'_3 = 2(N_3 - N_{LBK})$
 Good $N'_4 = 2(N_{LBK} + N_4)$
 ... N'_4 words with samples over threshold
 Skip $N'_5 = 2N_5$

- 2) If the algorithm works in positive logic, and
 $N_{LBK} = 0$;
 $N_5 \leq N_{LFWD} < N_3$;

then the readout event is:
 $N'_2 + N'_4 + N'_5 + 5$ (control words) + 1 (size)
 Skip $N'_1 = 2N_1$
 Good $N'_2 = 2(N_2 + N_{LFWD})$
 ... N'_2 words with samples over threshold
 Skip $N'_3 = 2(N_3 - N_{LFWD})$
 Good $N'_4 + N'_5$ ($N'_5 = 2N_5 \dots$)
 ... $N'_4 + N'_5$ words with samples over threshold

- 3) If the algorithm works in positive logic, and
 $N_{LBK} = 0$;
 $N_3 \leq N_{LFWD} < N_5$;

then the readout event is:

$N'_2 + 3$ (control words) + 1 (size)
Skip $N'_1 = 2N_1$
Good $N'_2 = 2(N_2 + N_3 + N_4 + N_{LFWD})$
... N'_2 words with samples over threshold
Skip $N'_5 = 2(N_5 - N_{LFWD})$

4) If the algorithm works in positive logic, and
 $N_3 \leq N_{LBK} < N_1$;
 $N_{LFWD} = 0$;

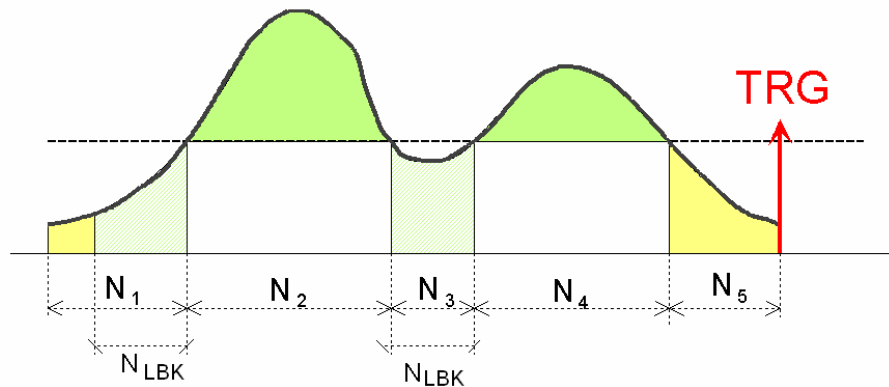

Fig. 3.12: Example with positive logic and overlapping N_{LBK}

then the readout event is:
 $N'_2 + N'_4 + 4$ (control words) + 1 (size)
Skip $N'_1 = 2(N_1 - N_{LBK})$
Good $N'_2 = 2(N_{LBK} + N_2)$
... N'_2 words with samples over threshold
Good $N'_4 = 2(N_3 + N_4)$
... N'_4 words with samples over threshold
Skip $N'_5 = 2N_5$
N.B: In this case there are two subsequent "GOOD" intervals.

5) If the algorithm works in positive logic, and
 $0 < N_{LBK} < N_1$;
 $N_{LFWD} < N_5$;
 $N_{LBK} + N_{LFWD} \geq N_3$.
then the readout event is:
 $N'_2 + N'_4 + 4$ (control words) + 1 (size)
Skip $N'_1 = 2(N_1 - N_{LBK})$
Good $N'_2 = 2(N_{LBK} + N_2 + N_{LFWD})$
... N'_2 words with samples over threshold
Good $N'_4 = 2(N_3 - N_{LFWD}) + 2N_4 + 2N_{LFWD}$
... N'_4 words with samples over threshold
Skip $N'_5 = 2(N_5 - N_{LFWD})$
N.B: In this case there are two subsequent "GOOD" intervals.

These examples are reported with positive logic; the compression algorithm is the same also working in negative logic.

3.5. Trigger management

All the channels in a board share the same trigger: this means that all the channels store an event at the same time and in the same way (same number of samples and same position with respect to the trigger); several trigger sources are available.

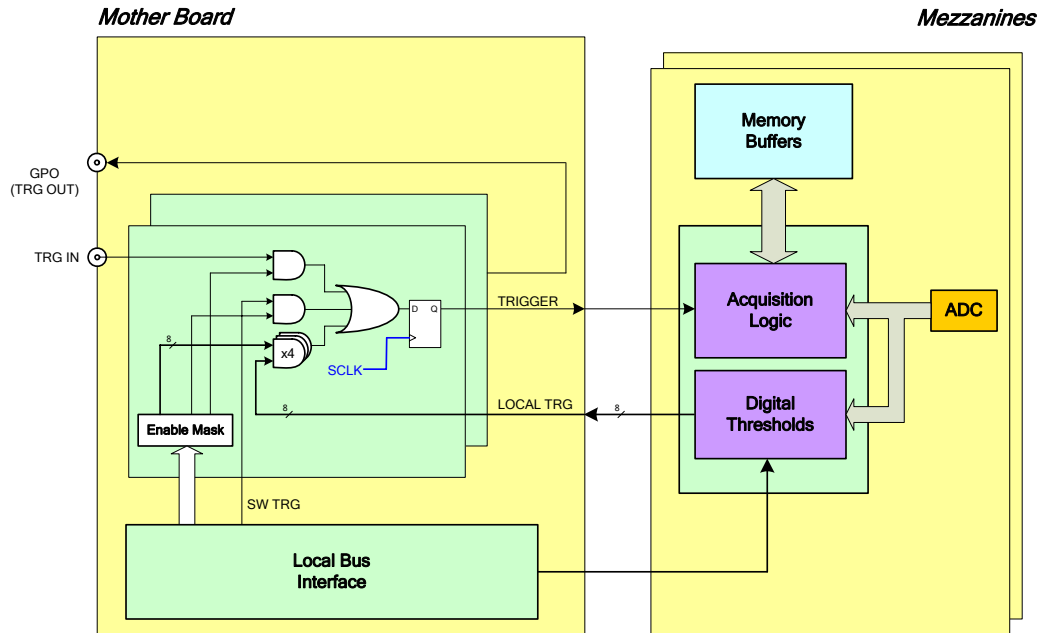

Fig. 3.13: Block diagram of Trigger management

3.5.1. External trigger

External trigger can be NIM/TTL signal on LEMO front panel connector, 50 Ohm impedance. The external trigger is synchronised with the internal clock (see § 3.2.1); if External trigger is not synchronised with the internal clock, a one clock period jitter occurs.

3.5.2. Software trigger

Software trigger are generated INTERNALLY (write access in the relevant register, see § 4.19).

3.5.3. Local channel auto-trigger

Each channel can generate a local trigger as the digitised signal exceeds the V_{th} threshold (ramping up or down, depending on register settings), and remains under or over threshold for Nth "4/5 samples groups" (depending on selected storage mode, see § 3.3.3) at least (Nth is programmable via register setting). The V_{th} digital threshold, the edge type, and the minimum number Nth of [4/5 samples] are programmable via register accesses, see § 4.3 and § 4.6; actually local trigger is delayed of Nth [4/5 samples] with respect to the input signal.

N.B.: the local trigger signal does not start directly the event acquisition on the relevant channel; such signal is propagated to the central logic which produces the global trigger, which is distributed to all channels (see § 3.5.4).

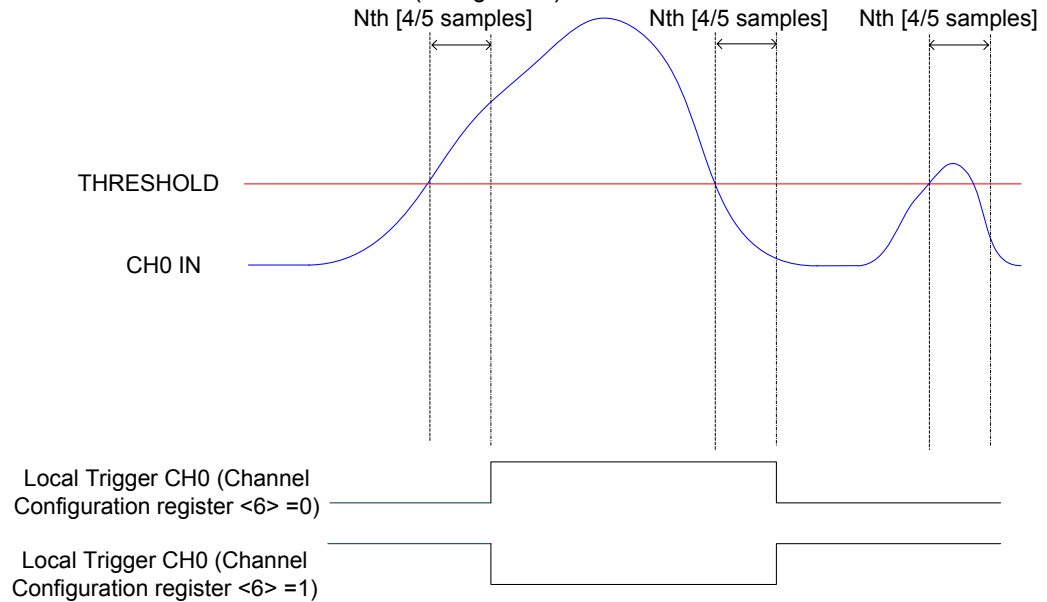

Fig. 3.14: Local trigger generation

3.5.3.1. Trigger coincidence level

It is possible to set the minimum number of channels that must be over threshold, beyond the triggering channel, in order to actually generate the local trigger signal. If, for example, Trigger Source Enable Mask (see § 4.20) bits[3:0]=F (all channels enabled) and Local trigger coincidence level = 1 (bits [26:24]), whenever an enabled channel exceeds the threshold, the trigger will be generated only if at least another channel is over threshold at that moment. Local trigger coincidence level must be smaller than the number of channels enabled via bit[3:0] mask. The following figure shows examples with Local trigger coincidence level = 1 and = 0.

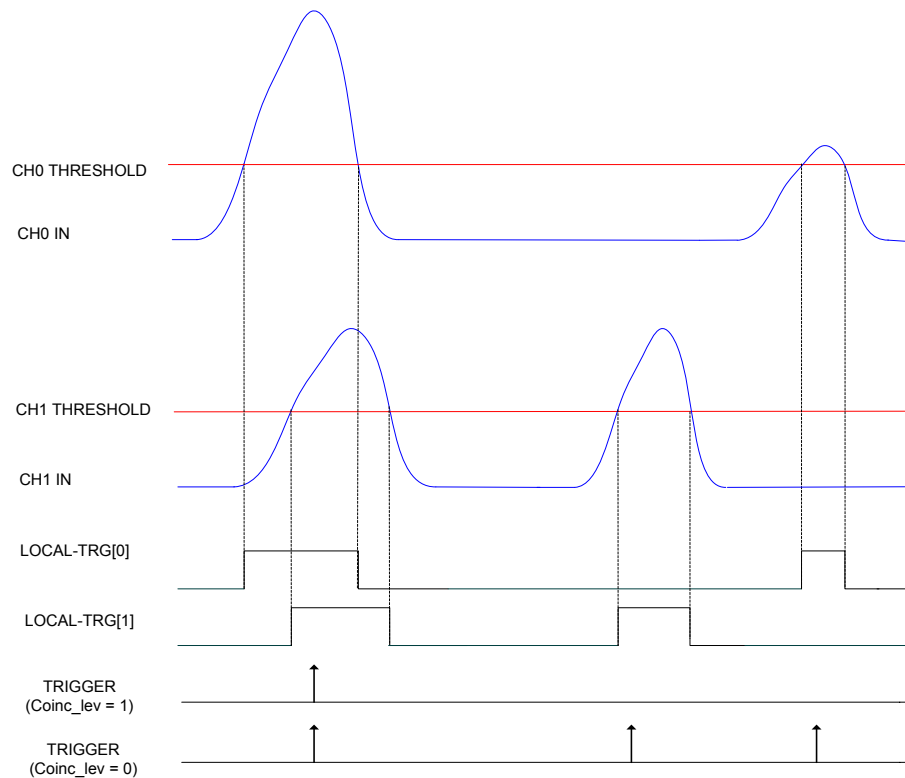

Fig. 3.15: Local trigger relationship with Coincidence level

3.5.4. Trigger distribution

The OR of all the enabled trigger sources, after being synchronised with the internal clock, becomes the global trigger of the board and is fed in parallel to all the channels, which store an event.

A Trigger Out is also generated on the relevant front panel GPO connector (NIM or TTL), and allows to extend the trigger signal to other boards.

For example, in order to start the acquisition on all the channels in the crate, as one of the channels ramps over threshold, the Local Trigger must be enabled as Trigger Out, the Trigger Out must then be fed to a Fan Out unit; the obtained signal has to be fed to the External Trigger Input of all the boards in the crate (including the board which generated the Trigger Out signal).

3.6. Data transfer capabilities

The board can be accessed by using software drivers and libraries developed by CAEN. Single 16/32 register read/write cycles, multi read cycles and block transfers are supported by the provided library (please consult the relevant documentation for details) Sustained readout rate is up to 60 MB/s for optical link, using block transfers, and up to 30 MB/s for a USB 2.0 link, using block transfers as well.

3.7. Events readout

Event readout is done by accessing the Event Readout Buffer (see § 4.1), a FIFO (First-In First-Out) memory that can be accessed into the 0x0000-0x0FFC address space.

Data transfer is always aligned to the programmed number N of events; let X the size of the event expected or read from dedicated register:

- If the event size is known, a read cycle equal to $N \times X$ will return all data without interruptions.
- If the number of data read from the Event Readout Buffer is higher than $N \times X$, transfer will be terminated anyway by DT5720 at the end of $N \times X$ data.
- If the event size X is unknown (for example in case of overlapping triggers), there are two cases:
 - data transfer $\leq N \times X$: all data will be returned.
 - data transfer $> N \times X$: only $N \times X$ data will be returned.

Once an event is read, the corresponding acquisition buffers are available to store new data.

During readout, the board can continue to store events in memory up to the maximum number of programmed buffers available; the acquisition process is therefore "dead-timeless": event storage is only interrupted if the combination of trigger and readout rate causes a memory full situation: all acquisition buffers are used and they have not been read yet.

In order to exploit the maximum readout rate allowed by the communication path (USB or optical link), it is suggested to perform block transfer read cycles of at least $N \times X$ data with N set to its maximum value, whether possible.

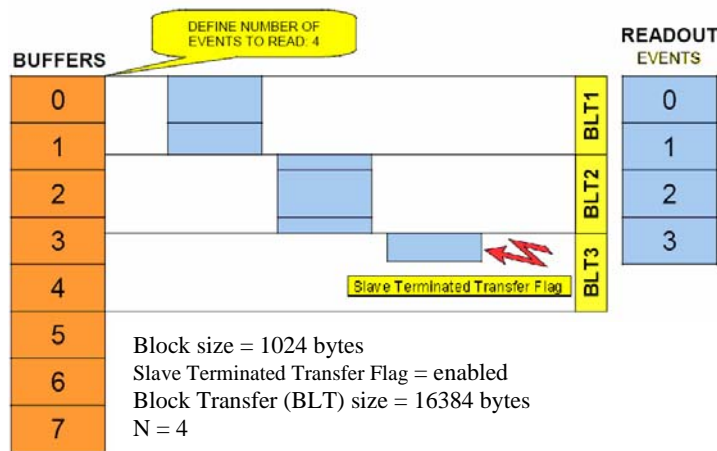

Fig. 3.16: Example of block transfer readout

3.8. Optical Link and USB access

The board houses a USB2.0 compliant port, providing a transfer rate up to 30 MB/s, and a daisy chainable Optical Link able to transfer data at 80 MB/s; the latter allows to connect up to eight DT5720 to a single Optical Link Controller: a standard PC equipped with the PCI card CAEN Mod. A2818.

The A2818 is a 32-bit 33 MHz PCI card; the communication path uses optical fiber cables as physical transmission line (see § 1.1).

A new type of PCIe communication card (A3818) with up to four optical links will be soon available (contact info@caen.it).

AY2705 and AY2720 have a duplex connector on the A2818 side and two simplex connectors on the board side; the simplex connector with the black wrap is for the RX line (lower) and the one with the red wrap is for the TX (higher see also § 2.4.5).

The Optical Link allows to perform read (Single data transfer and Block transfers) and write (Single data transfer) operations.

See also the web page: <http://www.caen.it/nuclear/product.php?mod=A2818>

Control Register bit 3 (see § 4.29) allows to enable the module to broadcast an interrupt request on the Optical Link; a bit mask (see Libraries, Demos and Software tools documentation) allows to enable the corresponding A2818's to propagate the interrupt on the PCI bus as a request from the Optical Link is sensed.

The module can be accessed either via Optical Link or USB. USB and Optical Link simultaneous access is anyway not recommended.

The following diagram shows how to connect DT5720 modules to the Optical Link:

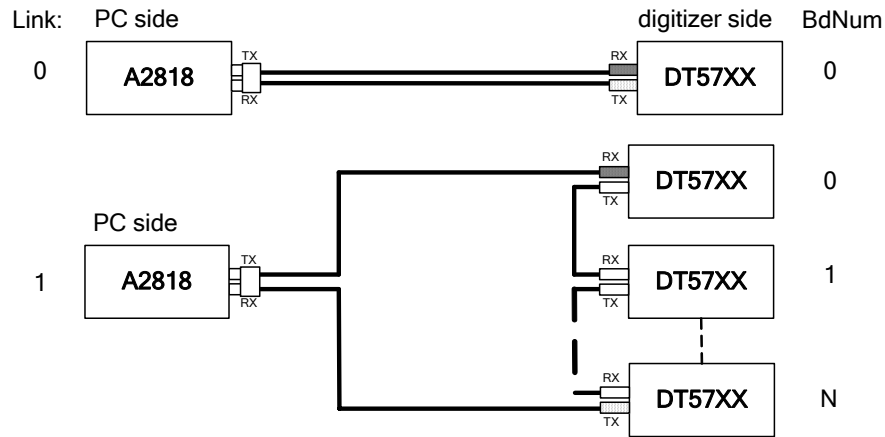

Fig. 3.17: Optical Link daisy chain

3.8.1. Software tools

CAEN provides Libraries, Demos and Software tools for Windows and Linux. The packages developed so far include:

- Libraries for National Instruments LabVIEW and C/C++
- Demo programs in source code C/C++ (Windows and Linux) and as a starting point for the development of user-specific applications
- Software Tools (firmware upgrade, Module configuration...)
- Windows 2000/XP/Vista. and Linux supported

4. Board internal registers

The following sections will describe in detail the registers (accessible via software in D32 mode) content.

4.1. Registers address map

Table 4.1: Address Map for the Model DT5720

REGISTER NAME	ADDRESS	MODE	H_RES	S_RES	CLR
EVENT READOUT BUFFER	0x0000-0x0FFC	R	X	X	X
Channel n ZS_THRES	0x1n24	R/W	X	X	
Channel n ZS_NSAMP	0x1n28	R/W	X	X	
Channel n THRESHOLD	0x1n80	R/W	X	X	
Channel n TIME OVER/UNDER THRESHOLD	0x1n84	R/W	X	X	
Channel n STATUS	0x1n88	R	X	X	
Channel n AMC FPGA FIRMWARE REVISION	0x1n8C	R			
Channel n BUFFER OCCUPANCY	0x1n94	R	X	X	X
Channel n DAC	0x1n98	R/W	X	X	
Channel n ADC CONFIGURATION	0x1n9C	R/W	X	X	
CHANNEL CONFIGURATION	0x8000	R/W	X	X	
CHANNEL CONFIGURATION BIT SET	0x8004	W	X	X	
CHANNEL CONFIGURATION BIT CLEAR	0x8008	W	X	X	
BUFFER ORGANIZATION	0x800C	R/W	X	X	
CUSTOM SIZE	0x8020	R/W	X	X	
ACQUISITION CONTROL	0x8100	R/W	X	X	
ACQUISITION STATUS	0x8104	R			
SW TRIGGER	0x8108	W			
TRIGGER SOURCE ENABLE MASK	0x810C	R/W	X	X	
FRONT PANEL TRIGGER OUT ENABLE MASK	0x8110	R/W	X	X	
POST TRIGGER SETTING	0x8114	R/W	X	X	
FRONT PANEL I/O CONTROL	0x811C	R/W	X	X	
CHANNEL ENABLE MASK	0x8120	R/W	X	X	
ROC FPGA FIRMWARE REVISION	0x8124	R			
EVENT STORED	0x812C	R	X	X	X
BOARD INFO	0x8140	R			
EVENT SIZE	0x814C	R	X	X	X
CONTROL	0xEF00	R/W	X		
STATUS	0xEF04	R			
INTERRUPT STATUS ID	0xEF14	R/W	X		
INTERRUPT EVENT NUMBER	0xEF18	R/W	X	X	
BLT EVENT NUMBER	0xEF1C	R/W	X	X	
SCRATCH	0xEF20	R/W	X	X	
SW RESET	0xEF24	W			
SW CLEAR	0xEF28	W			
FLASH ENABLE	0xEF2C	R/W	X		

REGISTER NAME	ADDRESS	MODE	H_RES	S_RES	CLR
FLASH DATA	0xEF30	R/W	X		
CONFIGURATION RELOAD	0xEF34	W			
CONFIGURATION ROM	0xF000-0xF088	R			

4.2. Configuration ROM (0xF000-0xF088; r)

The following registers contain some module's information, they are D32 accessible (read only):

- **OUI:** manufacturer identifier (IEEE OUI)
- **Version:** purchased version
- **Board ID:** Board identifier
- **Revision:** hardware revision identifier
- **Serial MSB:** serial number (MSB)
- **Serial LSB:** serial number (LSB)

Table 4.2: ROM Address Map for the Model DT5720

Description	Address	Content
checksum	0xF000	0xA4
checksum_length2	0xF004	0x00
checksum_length1	0xF008	0x00
checksum_length0	0xF00C	0x20
constant2	0xF010	0x83
constant1	0xF014	0x84
constant0	0xF018	0x01
c_code	0xF01C	0x43
r_code	0xF020	0x52
oui2	0xF024	0x00
oui1	0xF028	0x40
oui0	0xF02C	0xE6
vers	0xF030	0x30
board2	0xF034	0x02
board1	0xF038	0x16
board0	0xF03C	0x58
revis3	0xF040	0x00
revis2	0xF044	0x00
revis1	0xF048	0x00
revis0	0xF04C	0x00
sernum1	0xF080	
sernum0	0xF084	
VCXO type	0xF088	0x00 (AD9520-3)

These data are written into one Flash page; at Power ON the Flash content is loaded into the Configuration RAM, where it is available for readout.

4.3. Channel n ZS_THRES (0x1n24; r/w)

Bit	Function
[31]	0 = Positive Logic 1 = Negative Logic
[30:11]	<i>reserved</i>
[11:0]	The 12 LSB represent the value to be compared with each sample of the event, and see if it is "good" or "skip" type. (see § 3.4 and § 4.12)

4.4. Channel n ZS_NSAMP (0x1n28; r/w)

Bit	Function
[31:0]	With "Full Suppression based on the amplitude" (ZS AMP), bits [20:0] allow to set the number N _s of subsequent data which must be found over/under threshold (depending on the used logic) necessary to validate the event; if this field is set to 0, it is considered "1". With "Zero length encoding" (ZLE) bit [31:16] allows to set/read N _{LBK} : the number of data to be stored before the signal crosses the threshold. bit [15:0] allows to set/read N _{LFWD} : the number of data to be stored after the signal crosses the threshold (see § 3.4 and § 4.12)

4.5. Channel n Threshold (0x1n80; r/w)

Bit	Function
[11:0]	Threshold Value for Trigger Generation

Each channel can generate a local trigger as the digitised signal exceeds the V_{th} threshold, and remains under or over threshold for N_{th} [4 samples; 5 samples in Pack2.5 mode] at least; local trigger is delayed of N_{th} [4/5 samples] with respect to input signal. This register allows to set V_{th} (LSB=input range/12bit); see also § 3.5.3.

4.6. Channel n Over/Under Threshold (0x1n84; r/w)

Bit	Function
[11:0]	Number of Data under/over Threshold

Each channel can generate a local trigger as the digitised signal exceeds the V_{th} threshold, and remains under or over threshold for N_{th} [4/5 samples] at least; local trigger is delayed of N_{th} [4 samples; 5 samples in Pack2.5 mode] with respect to input signal. This register allows to set N_{th}; see also § 3.5.3.

4.7. Channel n Status (0x1n88; r)

Bit	Function
[5:3]	<i>reserved</i>
[2]	Channel n DAC (see § 4.10) Busy 1 = Busy 0 = DC offset updated
[1]	Memory empty
[0]	Memory full

4.8. Channel n AMC FPGA Firmware (0x1n8C; r)

Bit	Function
[31:16]	Revision date in Y/M/DD format
[15:8]	Firmware Revision (X)
[7:0]	Firmware Revision (Y)

Bits [31:16] contain the Revision date in Y/M/DD format.

Bits [15:0] contain the firmware revision number coded on 16 bit (X.Y format).

Example: revision 1.3 of 12th June 2007 is: 0x7612103

4.9. Channel n Buffer Occupancy (0x1n94; r)

Bit	Function
[10:0]	Occupied buffers (0..1024)

4.10. Channel n DAC (0x1n98; r/w)

Bit	Function
[15:0]	DAC Data

Bits [15:0] allow to define a DC offset to be added the input signal in the $\pm 1V$ range.

When Channel n Status bit 2 is set to 0, DC offset is updated (see § 4.7).

4.11. Channel n ADC Configuration (0x1n9C; r/w)

Bit	Function
[15:0]	T.B.D.

This register allows to pilot the relevant ADC signals. See the LTC2242-12 - 12-Bit, 250MSPS ADC data sheet for details.

4.12. Channel Configuration (0x8000; r/w)

Bit	Function
[19:16]	Allows to select Zero Suppression algorithm: 0000 = no zero suppression (default); 0010 = zero length encoding (ZLE); 0011 = full suppression based on the amplitude (ZS AMP)
[18:12]	<i>reserved</i>
[11]	0 = Pack2.5 disabled 1 = Pack2.5 enabled
[10:7]	<i>reserved</i>
[6]	0 = Trigger Output on Input Over Threshold 1 = Trigger Output on Input Under Threshold allows to generate local trigger either on channel over or under threshold (see § 4.3 and § 4.6)
[4]	Reserved (Must be always set to 1)
[3]	0 = Test Pattern Generation Disabled 1 = Test Pattern Generation Enabled
[1]	0 = Trigger Overlapping Not Enabled 1 = Trigger Overlapping Enabled Allows to handle trigger overlap (see § 3.3.2)
[0]	<i>reserved</i>

This register allows to perform settings which apply to all channels.

It is possible to perform selective set/clear of the Channel Configuration register bits writing to 1 the corresponding set and clear bit at address 0x8004 (set) or 0x8008 (clear) see the following § 4.13 and 4.14. Default value is 0x10.

4.13. Channel Configuration Bit Set (0x8004; w)

Bit	Function
[7:0]	Bits set to 1 means that the corresponding bits in the Channel Configuration register are set to 1.

4.14. Channel Configuration Bit Clear (0x8008; w)

Bit	Function
[7:0]	Bits set to 1 means that the corresponding bits in the Channel Configuration register are set to 0.

4.15. Buffer Organization (0x800C; r/w)

Bit	Function
[3:0]	BUFFER CODE

The BUFFER CODE allows to divide the available Output Buffer Memory into a certain number of blocks, according to the table in § 3.3.2.

A write access to this register causes a Software Clear, see § 4.36. This register must not be written while acquisition is running.

4.16. Custom Size (0x8020; r/w)

Bit	Function
[31:0]	0= Custom Size disabled N _{Loc} (≠0) = Number of memory locations per event (1 location = 2 samples or 2 locations = 5 samples when Pack2.5 mode is used, see § 3.3.3)

This register must not be written while acquisition is running.

4.17. Acquisition Control (0x8100; r/w)

Bit	Function
[6]	0 = Internal clock source 1 = External clock source
[5,4]	Reserved
[3]	0 = COUNT ACCEPTED TRIGGERS 1 = COUNT ALL TRIGGERS allows to reject overlapping triggers (see § 3.3.2)
[2]	0 = Acquisition STOP 1 = Acquisition RUN allows to RUN/STOP Acquisition
[1]	Reserved (set to 0)
[0]	0 = REGISTER-CONTROLLED RUN MODE 1 = GPI CONTROLLED RUN MODE

Bit [2] allows to Run and Stop data acquisition; when such bit is set to 1 the board enters Run mode and a Memory Reset is automatically performed. When bit [2] is reset to 0 the stored data are kept available for readout. In Stop Mode all triggers are neglected.

Bit [0] description:

- 0 = REGISTER-CONTROLLED RUN MODE: multiboard synchronisation via GPI front panel signal
 - RUN control: start/stop via set/clear of bit[2]
 - GATE always active (Continuous Gate Mode)
- 1 = GPI CONTROLLED RUN MODE: Multiboard synchronisation via GPI front panel signal
 - GPI works both as SYNC and RUN_START command
 - GATE always active (Continuous Gate Mode)

4.18. Acquisition Status (0x8104; r)

Bit	Function
[8]	Board ready for acquisition (PLL and ADCs are synchronised correctly) 0 = not ready 1 = ready This bit should be checked after software reset to ensure that the board will enter immediately run mode after RUN mode setting; otherwise a latency between RUN mode setting and Acquisition start might occur.
[7]	PLL Status Flag (see § 2.5.1): 0 = PLL loss of lock 1 = no PLL loss of lock NOTE: flag can be restored to 1 via read access to Status Register (see § 0)
[6]	PLL Bypass mode (see § 2.5.1): 0 = No bypass mode 1 = Bypass mode
[5]	Clock source: 0 = Internal 1 = External
[4]	EVENT FULL: it is set to 1 as the maximum nr. of events to be read is reached
[3]	EVENT READY: it is set to 1 as at least one event is available to readout
[2]	0 = RUN off 1 = RUN on
[1:0]	<i>reserved</i>

4.19. Software Trigger (0x8108; w)

Bit	Function
[31:0]	A write access to this location generates a trigger via software

4.20. Trigger Source Enable Mask (0x810C; r/w)

Bit	Function
[31]	0 = Software Trigger Disabled 1 = Software Trigger Enabled
[30]	0 = External Trigger Disabled 1 = External Trigger Enabled
[29:27]	<i>reserved</i>
[26:24]	Local trigger coincidence level (default = 0)
[23:4]	<i>reserved</i>
[3]	0 = Channel 3 trigger disabled 1 = Channel 3 trigger enabled

[2]	0 = Channel 2 trigger disabled 1 = Channel 2 trigger enabled
[1]	0 = Channel 1 trigger disabled 1 = Channel 1 trigger enabled
[0]	0 = Channel 0 trigger disabled 1 = Channel 0 trigger enabled

This register bits[0,3] enable the channels to generate a local trigger as the digitised signal exceeds the Vth threshold (see § 3.5.3). Bit0 enables Ch0 to generate the trigger, bit1 enables Ch1 to generate the trigger and so on.

Bits [26:24] allows to set minimum number of channels that must be over threshold, beyond the triggering channel, in order to actually generate the local trigger signal; for example if bit[3:0]=F (all channels enabled) and Local trigger coincidence level = 1, whenever one channel exceeds the threshold, the trigger will be generated only if at least another channel is over threshold at that moment. Local trigger coincidence level must be smaller than the number of channels enabled via bit[3:0] mask.

EXTERNAL TRIGGER ENABLE (bit30) enables the board to sense TRG-IN signals

SW TRIGGER ENABLE (bit 31) enables the board to sense software trigger (see § 4.19).

4.21. Front Panel Trigger Out Enable Mask (0x8110; r/w)

Bit	Function
[31]	0 = Software Trigger Disabled 1 = Software Trigger Enabled
[30]	0 = External Trigger Disabled 1 = External Trigger Enabled
[29:4]	<i>reserved</i>
[3]	0 = Channel 3 trigger disabled 1 = Channel 3 trigger enabled
[2]	0 = Channel 2 trigger disabled 1 = Channel 2 trigger enabled
[1]	0 = Channel 1 trigger disabled 1 = Channel 1 trigger enabled
[0]	0 = Channel 0 trigger disabled 1 = Channel 0 trigger enabled

This register bits[0,3] enable the channels to generate a TRG_OUT front panel signal on GPO output as the digitised signal exceeds the Vth threshold (see § 3.5.3).

Bit0 enables Ch0 to generate the TRG_OUT, bit1 enables Ch1 to generate the TRG_OUT and so on.

EXTERNAL TRIGGER ENABLE (bit30) enables the board to generate the TRG_OUT

SW TRIGGER ENABLE (bit 31) enables the board to generate TRG_OUT (see § 4.19).

4.22. Post Trigger Setting (0x8114; r/w)

Bit	Function
[31:0]	Post trigger value

The register value sets the number of post trigger samples. The number of post trigger samples is :

$N_{post} = PostTriggerValue * 4 + ConstantLatency$; where:

N_{post} = number of post trigger samples.

$PostTriggerValue$ = Content of this register.

$ConstantLatency$ = constant number of samples added due to the latency associated to the trigger processing logic in the ROC FPGA; this value is constant, but the exact value may change between different firmware revisions.

4.23. Front Panel I/O Control (0x811C; r/w)

Bit	Function
[15:2]	<i>reserved</i>
[1]	0= panel output signals (GPO) enabled 1= panel output signals (GPO) enabled in high impedance
[0]	0 = GPI/GPO/TRG-IN are NIM I/O Levels 1 = GPI/GPO/TRG-IN are TTL I/O Levels

4.24. Channel Enable Mask (0x8120; r/w)

Bit	Function
[7:4]	<i>reserved</i>
[3]	0 = Channel 3 disabled 1 = Channel 3 enabled
[2]	0 = Channel 2 disabled 1 = Channel 2 enabled
[1]	0 = Channel 1 disabled 1 = Channel 1 enabled
[0]	0 = Channel 0 disabled 1 = Channel 0 enabled

Enabled channels provide the samples which are stored into the events (and not erased).
The mask cannot be changed while acquisition is running.

4.25. ROC FPGA Firmware Revision (0x8124; r)

Bit	Function
[31:16]	Revision date in Y/M/DD format
[15:8]	Firmware Revision (X)
[7:0]	Firmware Revision (Y)

Bits [31:16] contain the Revision date in Y/M/DD format.

Bits [15:0] contain the firmware revision number coded on 16 bit (X.Y format).

4.26. Event Stored (0x812C; r)

Bit	Function
[31:0]	This register contains the number of events currently stored in the Output Buffer

This register value cannot exceed the maximum number of available buffers according to setting of buffer size register.

4.27. Board Info (0x8140; r)

Bit	Function
[23:16]	Number of channels (DT5720: 0x04; DT5720A: 0x02)
[15:8]	Memory size code (DT5720: 0x02)
[7:0]	Board Type (DT5720: 0x03)

4.28. Event Size (0x814C; r)

Bit	Function
[31:0]	Nr. of 32 bit words in the next event

4.29. Control (0xEF00; r/w)

Bit	Function
[7]	Reserved; must be set to 0, Release On Register Access (RORA) Interrupt mode
[6]	Reserved, must be set to 0
[5]	Reserved, must be set to 0
[4]	Reserved, must be set to 1
[3]	0 = interrupt disabled 1 = interrupt enabled
[2,1]	Reserved
[0]	Reserved (must be set to 0)

Interrupt request can be removed by accessing this register and disabling the active interrupt level

4.30. Status (0xEF04; r)

Bit	Function
[2]	0 = Slave Terminated Transfer Flag: no terminated transfer 1 = Slave Terminated Transfer Flag: one transfer has been terminated by DT5720 (unsupported register access or block transfer prematurely terminated in event aligned readout)
[1]	0 = The Output Buffer is not FULL; 1 = The Output Buffer is FULL.
[0]	0 = No Data Ready; 1 = Event Ready

4.31. Interrupt Status ID (0xEF14; r/w)

Bit	Function
[31..0]	This register contains the STATUS/ID that the module places on the data stream during the Interrupt Acknowledge cycle

4.32. Interrupt Event Number (0xEF18; r/w)

Bit	Function
[9:0]	INTERRUPT EVENT NUMBER

If interrupts are enabled, the module generates a request whenever it has stored in memory a Number of events > INTERRUPT EVENT NUMBER

4.33. Block Transfer Event Number (0xEF1C; r/w)

Bit	Function
[15:0]	This register contains the number of complete events which has to be transferred via Block Transfer (see § 3.7).

4.34. Scratch (0xEF20; r/w)

Bit	Function
[31:0]	Scratch (to be used to write/read words for test purposes)

4.35. Software Reset (0xEF24; w)

Bit	Function
[31:0]	A write access to this location allows to perform a software reset

4.36. Software Clear (0xEF28; w)

Bit	Function
[31:0]	A write access to this location clears all the memories

4.37. Flash Enable (0xEF2C; r/w)

Bit	Function
[0]	Reserved for Firmware upgrade tool

4.38. Flash Data (0xEF30; r/w)

Bit	Function
[7:0]	Data to be serialized towards the SPI On board Flash

This register is handled by the Firmware upgrade tool.

4.39. Configuration Reload (0xEF34; w)

Bit	Function
[31:0]	A write access to this register causes a software reset, a reload of Configuration ROM parameters and a PLL reconfiguration.

5. Installation

5.1. Power ON sequence

To power ON the board follow this procedure:

1. connect the 12V dc power supply to the DT5720
2. power up the DT5720

5.2. Power ON status

At power ON the module is in the following status:

- the Output Buffer is cleared;
- registers are set to their default configuration

5.3. Firmware upgrade

The DT5720 firmware is stored onto on-board non-volatile memory. CAEN provides a firmware upgrade tool that can be used with either USB or optical link paths. Please download the software package, application notes and user manual available at:

<http://www.caen.it/nuclear/product.php?mod=DT5720>

then follow the instructions for installation and usage.

WARNING: in case of programming failures, the board hosts a backup image of factory firmware.

Please contact CAEN at support.frontend@caen.it for instructions in order to restore the backup image.

Once the board is successfully powered with backup firmware, the standard firmware image can be reprogrammed.