



Politecnico di Torino

## Porto Institutional Repository

[Doctoral thesis] Design and development of a new large-scale metrology system: MScMS (Mobile Spatial coordinate Measuring System)

*Original Citation:*

Maisano Domenico (2008). *Design and development of a new large-scale metrology system: MScMS (Mobile Spatial coordinate Measuring System)*. PhD thesis

*Availability:*

This version is available at : <http://porto.polito.it/2544537/> since: May 2014

*Published version:*

DOI:[10.6092/polito/porto/2544537](https://doi.org/10.6092/polito/porto/2544537)

*Terms of use:*

This article is made available under terms and conditions applicable to Open Access Policy Article ("Public - All rights reserved") , as described at [http://porto.polito.it/terms\\_and\\_conditions.html](http://porto.polito.it/terms_and_conditions.html)

Porto, the institutional repository of the Politecnico di Torino, is provided by the University Library and the IT-Services. The aim is to enable open access to all the world. Please [share with us](#) how this access benefits you. Your story matters.

(Article begins on next page)

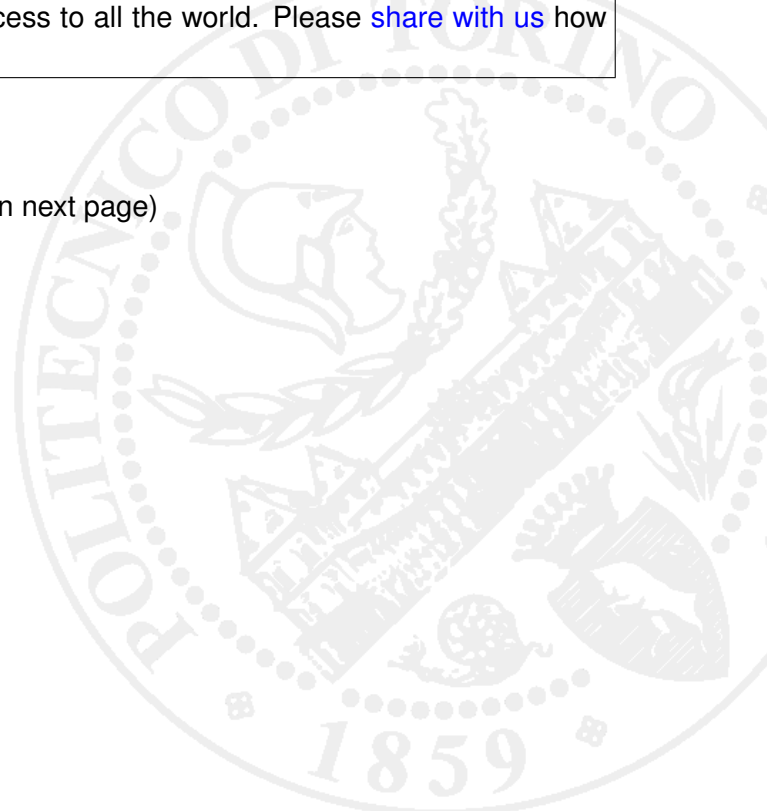

**POLITECNICO DI TORINO**

**DOCTORATE IN PRODUCTION SYSTEMS & INDUSTRIAL  
DESIGN**



**DESIGN AND DEVELOPMENT OF A NEW LARGE-SCALE  
METROLOGY SYSTEM: MSCMS (MOBILE SPATIAL  
COORDINATE MEASURING SYSTEM)**



Supervisor:  
Prof. F. Franceschini

Ph. D. Student:  
Domenico MAISANO

May 2008



## Executive summary

This thesis arises from the research activity developed at the Industrial Metrology and Quality Engineering Laboratory of DISPEA – Politecnico di Torino, on a new system prototype for dimensional measurement, called Mobile Spatial coordinate Measuring System (MScMS) [Franceschini et al., 2008-II]. MScMS determines dimensional features of large-size objects and has been designed to overcome some limits shown by other widespread measuring sets used nowadays, like Coordinate Measuring Machines (CMMs), theodolites/tacheometers, photogrammetry equipments, GPS based systems, Laser Trackers [Bosch, 1995; Pozzi, 2002].

Basing on a distributed sensor networks structure, MScMS can accomplish rapid dimensional measurements, in a wide range of indoor operating environments. It consists of distributed wireless devices, communicating with each other through radiofrequency (RF) and ultrasound (US) transceivers. This frame makes the system easy to handle and to move, and gives the possibility of placing its components freely around the workpiece. The wireless devices – known as “Crickets” – are developed by the Massachusetts Institute of Technology (MIT). Being quite small, light and potentially cheap (if mass produced), they fit to obtain a wide range of different network configurations [Priyantha et al., 2000; Balakrishnan et al., 2003].

These features make the new system suitable for particular types of measurement, which can not be carried out, for example, by conventional CMMs. Typical is the case of large-size objects which are unable to be transferred to the measuring system area (because of their dimensions or other logistical constraints) and thus require the measuring system to be moved to them.

In the dissertation the system is described exhaustively and characterized through practical experiments. Then, the system is compared to classical CMMs and the indoor-GPS (iGPS), an innovative laser based system for large-scale metrology. Finally, future directions of this research are given.



# Contents

<b>List of acronyms and abbreviations .....</b>	<b>vii</b>
<b>1. Introduction.....</b>	<b>1</b>
1.1 The Mobile Spatial coordinate Measuring System (MScMS) .....	1
1.2 The new paradigm of the distributed measuring systems .....	1
1.3 Literature review .....	1
1.4 Organization of the dissertation .....	1
<b>2. Principle functioning and MScMS architecture .....</b>	<b>1</b>
2.1 Introduction .....	1
2.2 System requirements and comparison with other measuring techniques .....	1
2.3 MScMS hardware equipment.....	1
2.3.1 Cricket devices.....	1
2.3.2 Evaluation of distances between Cricket devices .....	1
2.3.3 Crickets communication .....	1
2.3.4 The mobile probe .....	1
2.4 MScMS software architecture.....	1
2.4.1 Location of Crickets mounted on the mobile probe.....	1
2.4.2 Location of points touched by the probe tip.....	1
2.4.3 Cricket firmware .....	1
2.4.4 Semi-automatic location of the constellation.....	1
<b>3. MScMS prototype.....</b>	<b>1</b>
3.1 Introduction .....	1
3.2 Description of the first MScMS prototype.....	1
3.3 MScMS actual performance, critical aspects and possible improvements.....	1
3.4 Final considerations .....	1
<b>4. Experimental evaluation of the MScMS ultrasound transducers .....</b>	<b>1</b>
4.1 Introduction.....	1
4.2 Piezo-electric US transducers .....	1
4.3 Factors affecting US transceivers.....	1
4.4 Analysis of the experimental results .....	1
4.4.1 Results of the factorial plan .....	1
4.4.2 Interpretation of the results .....	1
4.4.3 Additional experiments .....	1
4.5 Final notes and future work.....	1
<b>5. MScMS and CMMs: a structured comparison.....</b>	<b>1</b>
5.1 Introduction .....	1
5.2 CMMs main characteristics.....	1
5.3 Comparison criteria.....	1
5.3.1 Portability.....	1

---

5.3.2	Working volume.....	1
5.3.3	Set up.....	1
5.3.4	Metrological performances .....	1
5.3.5	Measurements system diagnostics.....	1
5.3.6	Ease of use.....	1
5.3.7	Flexibility .....	1
5.3.8	Cost .....	1
5.3.9	System management.....	1
5.4	Final considerations.....	1
<b>6.</b>	<b>iGPS performance evaluation and comparison with MScMS .....</b>	<b>1</b>
6.1	Introduction .....	1
6.2	iGPS structure .....	1
6.3	iGPS technology and operating features .....	1
6.4	Factors affecting measurement.....	1
6.5	Experimental work for iGPS' preliminary performance analysis .....	1
6.6	Systems comparison.....	1
6.7	Summary and final considerations .....	1
<b>7.</b>	<b>Future wireless sensor networks.....</b>	<b>1</b>
7.1	Introduction .....	1
7.2	Typical features of sensor networks .....	1
7.3	Growth potential and future advancement .....	1
7.4	Final considerations.....	1
<b>8.</b>	<b>Conclusions and future directions .....</b>	<b>1</b>
	<b>References .....</b>	<b>1</b>

## List of acronyms and abbreviations

<b>2D</b>	two-dimensional
<b>3D</b>	three-dimensional
<b>CCD</b>	Charge Coupled Device
<b>CMM</b>	Coordinate Measuring Machine
<b>CNC</b>	Computer Numerical Control
<b>CSAIL</b>	Computer Science and Artificial Intelligence Lab
<b>DISPEA</b>	Dipartimento di Sistemi di Produzione ed Economia dell'Azienda
<b>DoE</b>	Design of Experiments
<b>EF</b>	Error Function
<b>GPS</b>	Global Position System
<b>GUM</b>	Guide to the expression of Uncertainty in Measurement
<b>ICT</b>	Information and Communications Technology
<b>IEC</b>	International Electrotechnical Commission
<b>IEEE</b>	Institute of Electrical and Electronics Engineers
<b>iGPS</b>	indoor GPS
<b>IP</b>	Internet Protocol
<b>LED</b>	Light Emitting Diode
<b>MIT</b>	Massachusetts Institute of Technology
<b>MPE</b>	Maximum Permitted Error
<b>MScMS</b>	Mobile Spatial coordinate Measuring System
<b>PC</b>	Personal Computer
<b>PVDF</b>	Polyvinylidene fluoride
<b>RF</b>	Radio Frequency
<b>RH</b>	Relative Humidity
<b>T</b>	Temperature
<b>TDoA</b>	Time Difference of Arrival
<b>TOF</b>	Time of flight
<b>US</b>	Ultrasound
<b>V-bar</b>	Vector bar
<b>VIM</b>	International Vocabulary of Basic and General Terms in Metrology
<b>WSN</b>	Wireless Sensor Network





# 1. Introduction

The field of large-scale metrology can be defined as the metrology of large machines and structures that is to say “the metrology of objects in which the linear dimensions range from tens to hundreds of meters” [Puttock, 1978]. There is an increasing trend for accurate measurement of length, in particular, the 3D coordinate metrology at length scales of 5m to 100m has become a routine requirement in industries such as aircraft and ship construction. In this direction, there have been significant advances across a broad range of technologies, including laser interferometry, absolute distance metrology, very high density CCD (Charge-Coupled Device) cameras and so on.

Many types of metrological equipments, utilizing different kind of technologies (optical, mechanical, electromagnetic etc.), give physical representations of measured objects in a three-dimensional Cartesian coordinate system. Coordinate Measuring Machines (CMMs), theodolites/tacheometers, photogrammetry equipments, GPS (Global Positioning Systems), Laser Trackers are typical instruments to do it. Each of these systems is more or less adequate, depending on measuring conditions, user’s experience and skill, and other factors like time, cost, size, accuracy, portability etc.. Classical CMMs, that make possible performing repeated and accurate measurements on objects which are even complexly shaped, are widespread. On the other hand, CMMs are generally bulky and not always suitable for measuring large size objects (for example, longerons of railway vehicles, airplane wings, fuselages etc..), because the working volume is limited [ISO 10360, part 2, 2001]. In general, for measuring medium-large size objects, portable systems can be preferred to fixed ones. Transferring the measuring system to the measured object place is often more practical than the vice-versa [Bosch, 1995]. Systems as theodolites/tacheometers, photogrammetry equipments, Laser Trackers, or GPS – rather than CMMs – can be easily installed and moved [Pozzi, 2002]. However, they can have some other drawbacks as mentioned in the remaining of this thesis (Section 2.2).

## 1.1 The Mobile Spatial coordinate Measuring System (MScMS)

This thesis introduces a new measuring system called Mobile Spatial coordinate Measuring System (MScMS), developed at the Industrial Metrology and Quality Laboratory of DISPEA – Politecnico di Torino. MScMS has been designed to perform simple and rapid indoor dimensional measurements of large-size objects (large scale metrology). An essential requirement for the system is portability – that is the aptitude to be easily transferred and installed.

MScMS is made up of three basic parts: (1) a “constellation” of wireless devices (Cricketts), (2) a mobile probe, and (3) a PC to store and elaborate data [MIT C.S.A.I.L., 2004]. Cricketts and mobile probe exploit ultrasound (US) transceivers in order to evaluate mutual distances. The constellation devices act as reference points, essential for the location of the probe.

Each US device has a communication range limited by a cone of transmission within an opening angle of about  $170^\circ$  and a maximum distance of no more than 8 m. The mobile probe location in the working volume is obtained by a trilateration. Consequently, the probe can be located only if it communicates with at least 4 constellation devices at once [Akcan et al., 2006].

The system makes it possible to calculate the position – in terms of spatial coordinates – of the object points “touched” by the probe. Acquired data are then available for different types of elaboration to determine the geometric features of the measured objects (distances, curves or surfaces).

One of the most critical aspects in the system set-up is the constellation devices positioning. Constellation devices operate as reference points, or beacons, for the mobile probe. In principle, Cricketts can be positioned without restriction all around the measured object. However, the number and position of constellation devices are strongly related to the dimensions and shape both of the measuring volume and the measured object. It is important to assure a full coverage of the space served by constellation devices by a proper alignment of US transmitters. The spatial location of the constellation devices follows a semi-automatic procedure. The accuracy in the location of constellation devices is fundamental for the accuracy in the next mobile probe location [Patwary et al., 2005].

## 1.2 The new paradigm of the distributed measuring systems

For the purpose of discussion, the large-scale dimensional measurement systems can be classified into *centralized* and *distributed* systems. In the case of centralized instruments, measurements may independently arise by a single stand-alone unit which is a centralized complete system (i.e. a CMM, a laser-scanner or a Laser Tracker), while distributed instruments are made of two or more distributed units (i.e. MScMS or other innovative systems like the indoor-GPS, described in Chap. 6 [Metris, 2007]).

Distributed measurement systems introduce a new paradigm in the field of large-scale metrology. Due to their nature, they are portable and can be easily transferred around the area where the measurand is. Compared to centralized systems, distributed systems may cover larger measuring areas, with no need for repositioning the instrumentation devices around the measured object [Kang et Tesar, 2004].

MScMS can be classified as a modular distributed measuring system for large volume objects. Even if at present time MScMS is still a prototype and needs to be further developed, the system enables factory-wide location of multiple objects, applicable in manufacturing and assembly. Mainly, it can be used by aerospace manufacturers, but can also be adopted by automotive and industrial manufacturers both for positioning and tracking applications. Since MScMS main components are a number of wireless devices distributed around the measuring area, this not rigidly connected frame makes the system easy to handle and to move, and gives the possibility of placing its components freely around the workpiece, adapting to the environment and not requiring particular facilities. As a consequence, MScMS is suitable for particular types of measurement, which can not be carried out by traditional frame instruments, like conventional CMMs, because they are bulky and cannot be comfortably moved.

The introduction of distributed measuring systems will probably have important effects on simplifying the current measuring practices within large scale industrial metrology [Maisano et al., 2007]. This tendency is confirmed by other recent distributed measuring systems based on laser and optical technology: the indoor-GPS (iGPS), the Portable-CMM and the Hi-Ball [ARC Second, 2004; Metris, 2007; Metronor, 2007; Welch et al., 2001]. All these systems – even they use different technologies – are composed of a number of sensors, arranged around the measuring area, which can be viewed by a sensor probe measuring the object surface.

### 1.3 Literature review

Dramatic advances in integrated circuits and radio technologies have made the use of distributed wireless sensor networks (WSNs) possible for many applications [Neil, 2005]. Recently, the attention towards the utilization of systems based on distributed sensor devices in manufacturing is increasing. Since sensor devices do not need cables and may be easily deployed or moved, they can be practically utilized for a variety of industrial applications – factory logistics and warehousing, environmental control and monitoring, support for assembly processes, industrial dimensional measuring and real-time surveillance are only some possible applications. While outdoor localization applications are widespread today (e.g. Global Positioning System – GPS), indoor applications can also benefit from location determination knowledge [Gotsman and Koren, 2004]. To make such applications feasible, the device costs should be low and the network should be organized without significant human involvement.

To give a concrete idea of the potential of the systems based on WSNs in manufacturing, here are briefly introduced some of the most interesting research issues with the corresponding bibliographic references.

*Support for final assembly.* Ultrasonic sensors are mounted on power tools – for example screwdrivers – to detect their real position and activate them if they are in the right position, during final assembly [Pepperl+Fuchs, 2005].

*Industrial control and monitoring.* Sensor devices can be deployed to perform industrial control and monitoring (for instance control of the air conditions of pollution, temperature, and pressure in different areas of the factory) or for emergency responses in case of incidents [Doss and Chandra, 2005; Pan et al., 2006; Koumpis et al., 2005; Oh et al., 2006].

*Factory logistics and warehousing.* In an industrial warehouse mobile forklifts generally move along corridors in order to reach the shelves where goods are stored. Forklifts and shelves can be equipped with ultrasound transceivers that communicate with each other, with the purpose of evaluating mutual distances [Intel Corporation, 2005]. This type of wireless sensor network can be utilized to calculate the position of the forklifts for:

- Indoor Navigation. Mobile forklifts, equipped with wireless transceiver, are automatically guided towards their destination [Wang and Xi, 2006];

- **Traffic Monitoring.** The physical traffic can be monitored in order to identify the most congested areas or to improve goods distribution [Capkun et al., 2001].

*Large-scale dimensional measuring.* Besides the MScMS, two innovative measuring systems for large scale dimensional measurements are the 3rd Tech Hi-Ball and Metris iGPS [Welch et al., 2001; Rooks, 2004; Metris, 2007]. These systems – all based on optical technologies and recently industrialised – are lightweight and very accurate, but they are relatively high priced and generally require a relatively large time for installation and start-up. Recently, the iGPS performance was studied and tested during a three months research activity carried out at the University of Bath (UK), attending the project LVMA (Large Volume Metrology Assembly – <http://www.bath.ac.uk>). A detailed description of this system and a comparison with MScMS is presented in Chap. 6.

## 1.4 Organization of the dissertation

The remainder of this dissertation contains a detailed description of the principle functioning and the implementation of MScMS. Then, the system performance is evaluated and compared with two other existing systems for large-scale dimensional measurements: the CMMs and the iGPS. More specifically, the thesis is structured like this:

- Chap. 2 presents the MScMS design features and *modus operandi*. In particular, the attention is focused on the system principle functioning and the hardware/software architecture.
- Chap. 3 describes the first MScMS prototype, presenting a preliminary experimental evaluation of its metrological performance. Also, this chapter identifies the system critical aspects and possible improvements.
- Chap. 4 concentrates the attention on the main features of the US transceivers equipping the system. They are deeply analysed by means of a structured experimental plan.
- Chap. 5 provides a structured comparison between MScMS and the classical CMMs.
- Chap. 6, discusses the iGPS technological features and principle, and provides a comparison with the MScMS.
- Chap. 7 presents a short general analysis of the development of WSNs. This can be interesting, considering that MScMS and other innovative measuring systems are based on distributed WSNs.

- Finally, Chap. 8 summarizes the thesis contributions and mentions possible future directions for improving the MScMS performance.

## **2. Principle functioning and MScMS architecture**

### **2.1 Introduction**

The purpose of this chapter is to describe the MScMS hardware/software/firmware architecture and functionalities.

Before introducing MScMS, in Section 2.2 we provide a structured description of requirements and functionalities that a generic system for large-scale dimensional measurements should meet. At the same time, we present a taxonomy of the most common techniques and metrological equipments for dimensional measuring. Major advantages and drawbacks are highlighted. The attention is subsequently focused on the MScMS design, analysing in detail the following aspects: hardware and software configuration, discussion of the location algorithms implemented by MScMS, description of the semi-automatic procedure for the spatial location of the MScMS constellation devices.

### **2.2 System requirements and comparison with other measuring techniques**

MScMS has been designed to perform dimensional measurements of medium-large size objects – with dimensions up to 30÷60 meters. It should be easy to move and install, low-priced and able to work indoor (inside warehouses, workshops, laboratories).

Tab. 2.1 identifies the MScMS basic requirements.

Considering them, we briefly analyse the most common measuring tools and techniques. Tab. 2.2 shows the result of a qualitative comparison among five measuring instruments: theodolite/tacheometer, CMM, Laser Tracker, photogrammetry system, and GPS. The last row of the table takes account of MScMS target performances.

Different considerations rise from Tab. 2.2. CMMs – in spite of being very accurate measuring instruments – are expensive, bulky and not easily movable. On the other hand, theodolites or GPS are smaller and lighter but not very flexible, in terms of different types of measurements offered. Even more, GPS systems are less accurate, and cannot operate indoor. Interferometrical Laser Trackers and digital photogrammetry equipments



are extremely accurate, but complex and expensive at the same time [Sandwith and Predmore, 2001]. Points to be measured need to be identified by the use of reflective markers or projected light spots. Theodolites/tacheometers are typically used in topography, but are not suitable to measure complex shaped objects.

**Tab. 2.1** Definition and description of MScMS basic requirements

<b>Requirement</b>	<b>Description</b>
Portability	Easy to move, easy to assemble/disassemble, lightweight and small sized.
Fast Installation and Start-Up	Before being ready to work, system installation, start-up or calibration should be fast and easy to perform.
Low Price	Low costs of production, installation and maintenance.
Metrological Performances	Appropriate metrological performances, in terms of stability, repeatability, reproducibility and accuracy [ISO 5725, 1986].
Working Volume	The area covered by the instrument, should be wide enough to perform measurements of large size objects (dimensions up to 30÷60 meters).
Easy Use	System should be user-friendly. An intuitive software interface should guide the user through measurements.
Work Indoor	System should be able to work indoor (inside warehouses, workshops, or laboratories).
Flexibility	System should be able to perform different measurement typologies (i.e. determination of point coordinates, distances, curves, surfaces etc..).

**Tab. 2.2.** Measuring systems comparison: qualitative performance evaluation

<b>MEASURING SYSTEM</b>	<b>REQUIREMENTS</b>							
	<i>Portability</i>	<i>Installation and Start-Up</i>	<i>Cost</i>	<i>Metrological Performances</i>	<i>Working Volume</i>	<i>Easy Use</i>	<i>Work Indoor</i>	<i>Flexibility</i>
<b>THEODOLITE</b>	HIGH	FAST	LOW	LOW	LARGE	MEDIUM	YES	LOW
<b>CMM</b>	LOW	SLOW	HIGH	HIGH	SMALL	HIGH	YES	HIGH
<b>LASER TRACKER</b>	MEDIUM	MEDIUM	MEDIUM	HIGH	LARGE	LOW	YES	MEDIUM
<b>PHOTOGRAMMETRY</b>	MEDIUM	SLOW	MEDIUM	MEDIUM	MEDIUM	LOW	YES	MEDIUM
<b>GPS</b>	HIGH	FAST	MEDIUM	LOW	LARGE	HIGH	NO	LOW
<b>MScMS (Purpose)</b>	HIGH	MEDIUM	LOW	MEDIUM	LARGE	HIGH	YES	HIGH

<b>Key</b>	☺
	☹
	☹

In conclusion, none of the previous measuring systems fulfil all previous requirements. MScMS is a system, based on the WSN technology, able to make a trade-off among these requirements.

### 2.3 MScMS hardware equipment

MScMS is made up of three basic parts [Franceschini et al., 2008-II]:

1. a “constellation” of wireless devices, distributed around the measuring area;
2. a mobile probe to register the coordinates of the object “touched” points;
3. a PC to store data sent – via Bluetooth – by the mobile probe and an *ad hoc* application software.

The mobile probe is equipped with two wireless devices, identical to those making up the constellation. These devices, known as Crickets, are developed by Massachusetts Institute of Technology and Crossbow Technology. They utilize two US transceivers in order to communicate and evaluate mutual distances [MIT C.S.A.I.L., 2004; Crossbow Technology, 2008]

The system makes it possible to calculate the position – in terms of spatial coordinates – of the object points “touched” by the probe. More precisely, when a trigger mounted on the mobile probe is pulled, the current coordinates of the probe tip are calculated and sent to a PC via Bluetooth. Acquired data are then available for different types of elaboration (determination of distances, curves or surfaces of measured objects).

Constellation devices (Crickets) operate as reference points, or beacons, for the mobile probe. The spatial location of the constellation devices follows a semi-automatic procedure, described in Subsection 2.4.4. Constellation devices are distributed without constraint around the object to measure. In the following subsections, we describe the MScMS hardware, focusing on:

- the wireless (Crickets) devices (Subsection 2.3.1);
- the measuring method to evaluate mutual distances among Crickets (Subsection 2.3.2);
- the mobile probe (Subsection 2.3.3).

### 2.3.1 Cricket devices

Cricket devices are equipped with radiofrequency (RF) and ultrasound (US) transceivers. Working frequencies are respectively 433 MHz (on RF) and 40 kHz (on US). Cricket devices are developed by Massachusetts Institute of Technology and manufactured by Crossbow Technology. Each device uses an Atmega 128L microcontroller operating at 7.4 Mhz, with 8 kBytes of RAM, 128 kBytes of FLASH ROM (program memory), and 4 kBytes of EEPROM (as mostly read-only memory). Alimentation is provided by two “AA” batteries of 1.5 V [Balakrishnan et al., 2003].

Cricket devices are quite small (see Fig. 2.1) easy to be moved, and cheap (each unit would cost about 10÷20 €, if mass-produced). Due to these characteristics, they are optimal for *ad hoc* WSN applications [Priyantha et al., 2000].

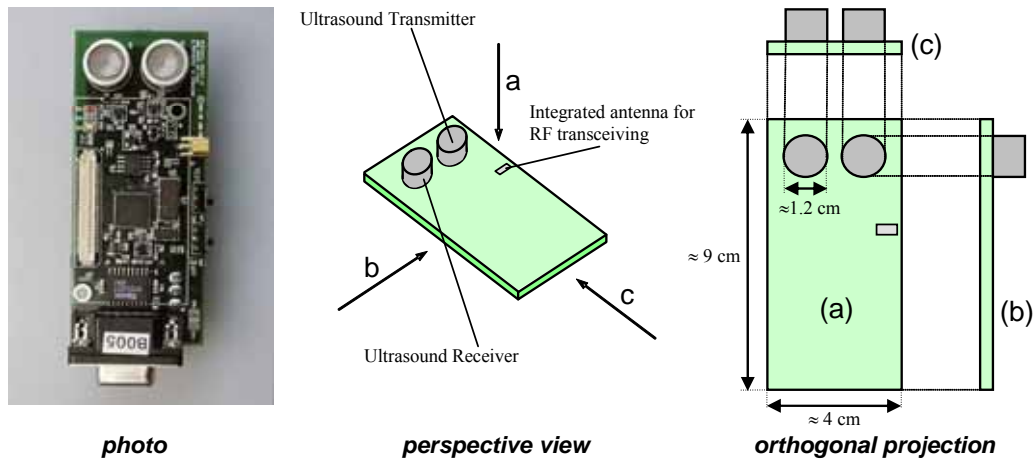

**Fig. 2.1.** Cricket Device (Crossbow Technology)

The US transceivers equipping Crickets are quartz crystals, which transform electric energy in acoustic, and vice-versa (piezo-electric effect). They generate/receive 40 kHz ultrasound waves. Transmitters, excited by electric impulses, vibrate at the resonance frequency producing acoustic ultrasound impulses [ANSI/IEEE Std. 176-1987, 1988]. On the other hand, receivers transform the vibration produced by ultrasonic waves in electric impulses. A detailed characterization of these transducers is presented in Chap. 4.

### 2.3.2 Evaluation of distances between Cricket devices

Cricket devices continuously communicate each other in order to evaluate mutual distances. Devices communication range is typically 6-8 meters, in absence of interposed obstacles.

The technique, implemented by each pair of Crickets to estimate mutual distance, is known as Time Difference of Arrival (TDoA). It is based on the comparison between the propagation time of two signals with different speed (RF and US in this case) [Savvides et al., 2001]. TDoA technique is described as follows:

- a) At random time intervals, included between 150 and 350 milliseconds, each device transmits a RF query-packet to other devices within its communication range, checking

if neighbouring Crickets are ready to receive a US signal (Fig. 2.2-a) [Priyantha et al., 2000];

b) Ready devices reply sending a RF acknowledgement authorizing next signals transmission (Fig. 2.2-b);

c) Querying Cricket is now authorized to concurrently send a RF and US signal (Fig. 2.2-c);

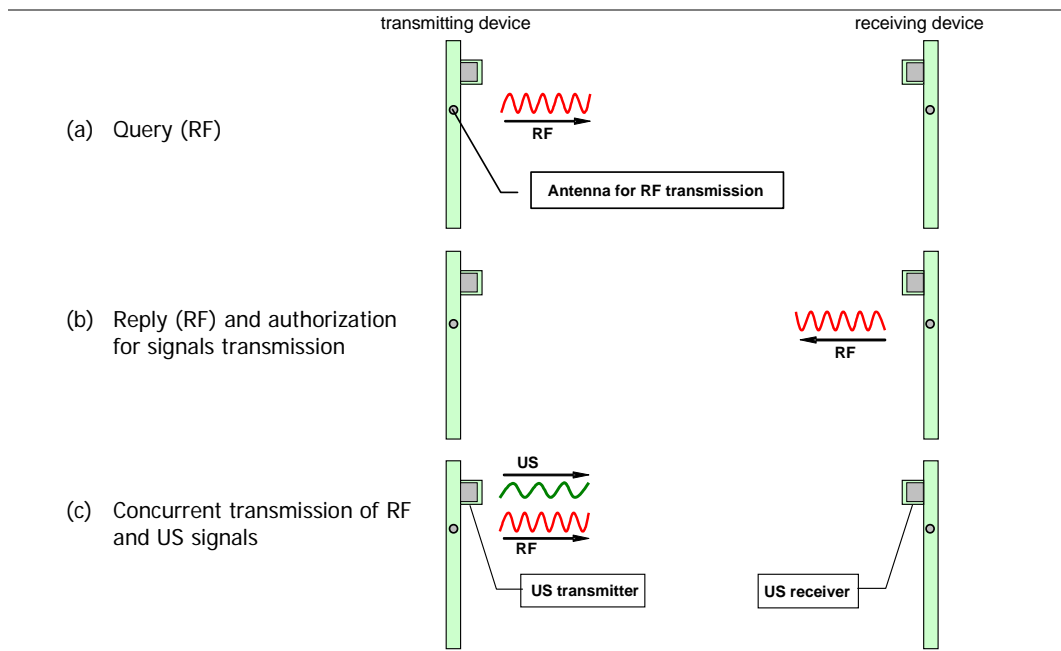

**Fig. 2.2.** Communication scheme implemented by Cricket devices [Priyantha et al., 2000]

d) The receiving devices measure the time lapse between reception of RF and US signals (see Fig. 2.3).

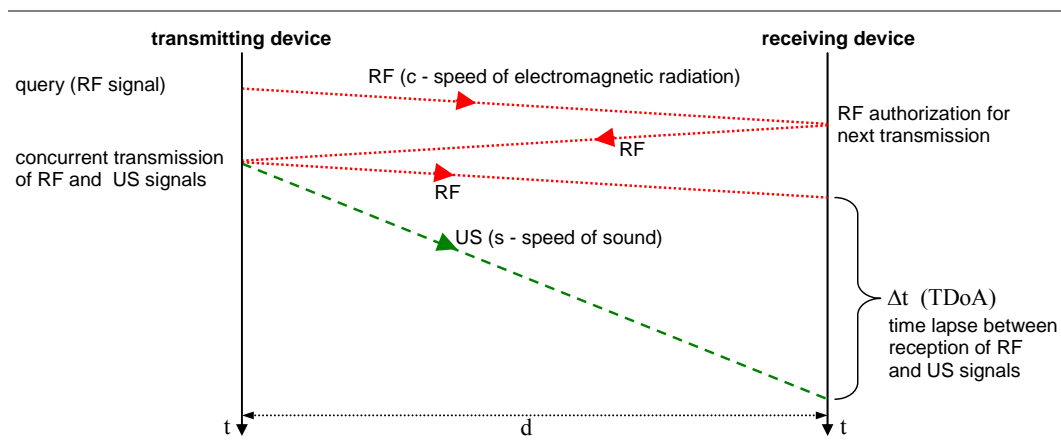

**Fig. 2.3.** Time evolution of RF and US signals: qualitative scheme

The distance between two devices is calculated by the following formula:

$$d = \frac{\Delta t}{\frac{1}{s} - \frac{1}{c}} \quad (2.1)$$

where  $c$  is the speed of electromagnetic radiations,  $s$  the speed of sound, and  $\Delta t$  is TDoA [Gustafsson and Gunnarsson, 2003].

Due to the large difference between  $c$  (about 300,000 km/s) and  $s$  (about 340 m/s in air, with temperature  $T=20^\circ\text{C}$  and relative humidity  $\text{RH} = 50\%$ ):

$$d \approx s \cdot \Delta t \quad (2.2)$$

### 2.3.3 Crickets communication

Cricket devices build a wireless network of cooperating sensor nodes. To preserve network scalability, that is to make sure that the amount of information stored by each node is independent from network dimension (in terms of nodes), each node memorizes the distances from its direct neighbours contained in the communication range (see Fig. 2.4).

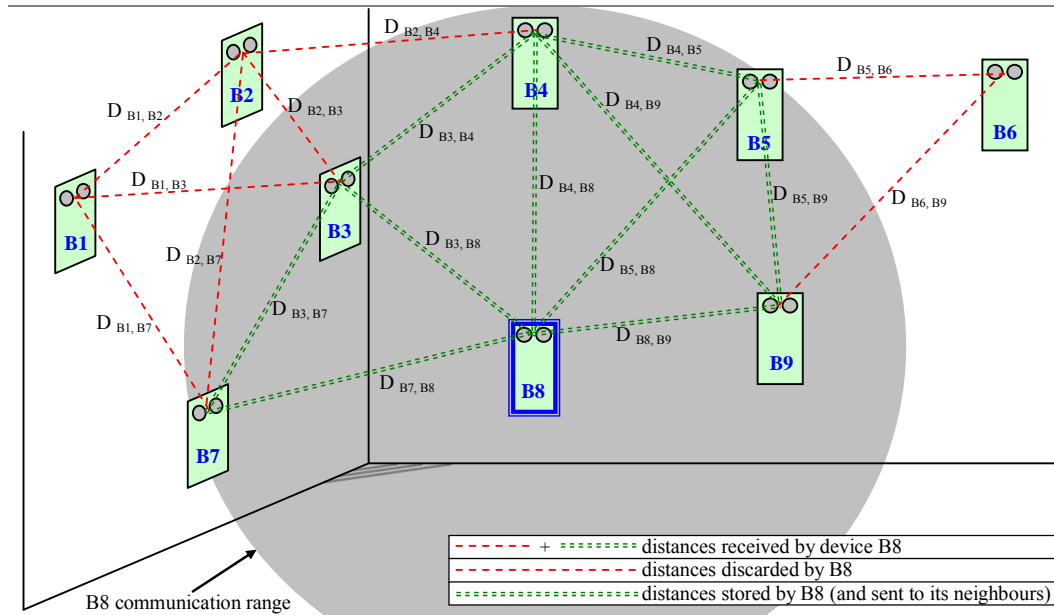

**Fig. 2.4.** Distance information handled by a single device (B8) . The shadow highlights the B8 communication range

### 2.3.4 The mobile probe

The mobile probe is equipped with two Cricket devices aligned with the tip and has a Bluetooth transmitter for sending data to the PC (see Fig. 2.5).

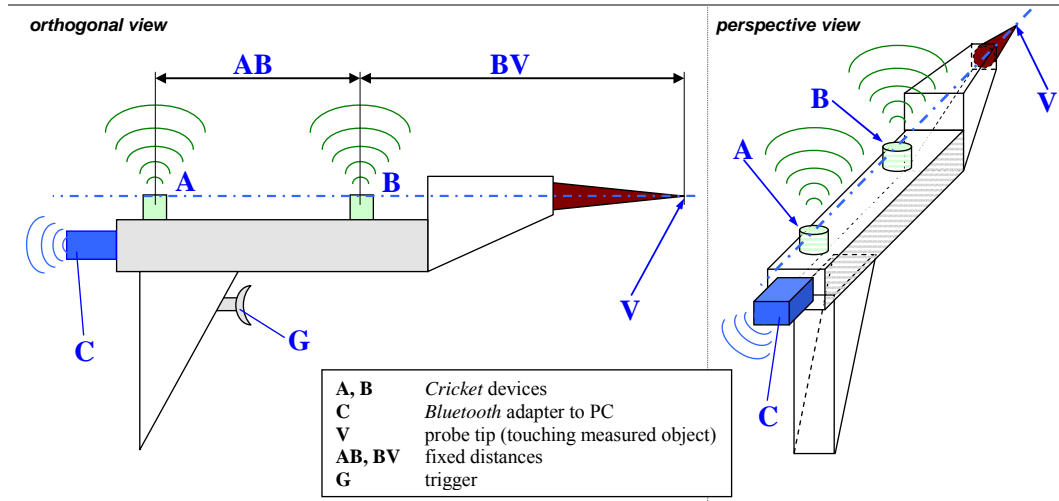

**Fig. 2.5.** Schematic representation of the mobile probe

The probe's Crickets locate themselves using the distance information from the constellation Crickets. The principle is described in Subsection 2.4.1.

System has been designed to be deployed over small or wide areas, depending on the dimension of the measured objects. The measuring area can be "covered" varying the number of constellation Crickets.

## 2.4 MScMS software architecture

This section describes software/firmware features of MScMS for implementing the following operations:

- location of Crickets mounted on the mobile probe;
- location of points touched by the probe;
- communication and data sharing among Cricket devices;
- semi-automatic location of constellation devices.

Fig 2.6 represents the first three operations. All operations are better described in the following subsections.

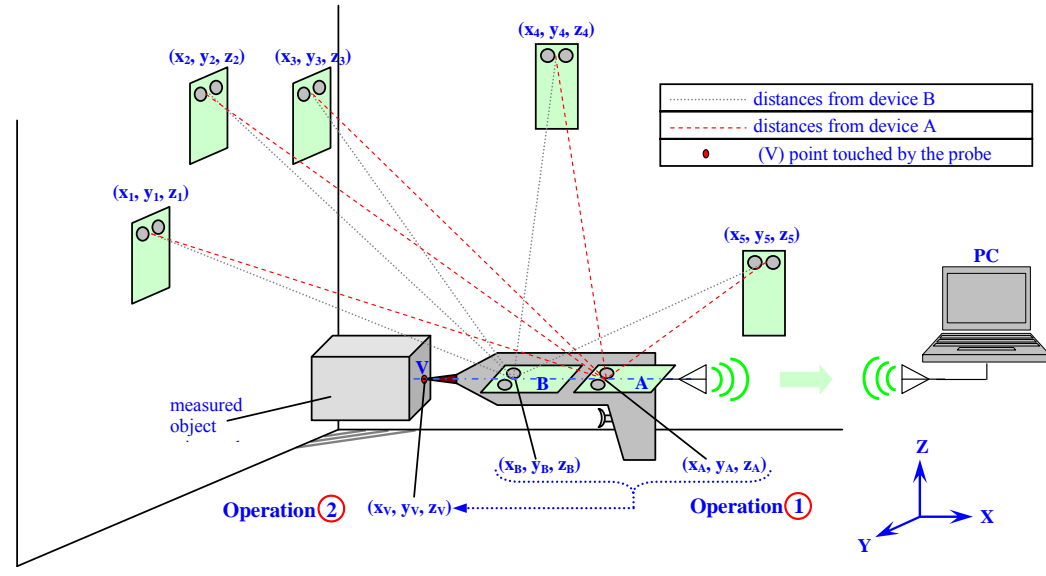

Fig. 2.6. Location of points touched by the probe

#### 2.4.1 Location of Crickets mounted on the mobile probe

Spatial location of each Cricket probe is performed using a trilateration technique. Trilateration uses the known locations of beacon reference points. To uniquely determine the relative location of a point on a 3D space, at least 4 reference points are generally needed [Chen et al., 2003; Sandwith and Predmore, 2001; Akcan et al., 2006].

In general, a trilateration problem can be formulated as follows. Given a set of  $n$  nodes (constellation devices) with known coordinates  $(x_i, y_i, z_i, \text{ being } i=1 \div n)$  and a set of measured distances  $M_i$ , a system of equations can be solved to calculate the unknown position of a generic point  $P(u, v, w)$  (see Fig. 2.7).

$$\begin{bmatrix} (x_1-u)^2+(y_1-v)^2+(z_1-w)^2 \\ (x_2-u)^2+(y_2-v)^2+(z_2-w)^2 \\ \vdots \\ (x_n-u)^2+(y_n-v)^2+(z_n-w)^2 \end{bmatrix} = \begin{bmatrix} M_1^2 \\ M_2^2 \\ \vdots \\ M_n^2 \end{bmatrix} \quad (2.3)$$

If the trilateration problem is over defined (4 or more reference points), it can be solved using a least-mean squares approach [Savvides et al., 2001; Martin et al., 2002].

Each unknown node (generically  $P$ ) estimates its position by performing the iterative minimization of an Error Function (EF), defined as:

$$EF = \frac{\sum_{i=1}^n [M_i - G_i]^2}{n} \quad (2.4)$$

being:

$M_i$  measured distance between the  $i$ -th node and the unknown device (P);

$G_i$  calculated distance between the estimated position of  $P \equiv (u, v, w)$  and the known position of the  $i$ -th device  $C_i \equiv (x_i, y_i, z_i)$ ;

$n$  number of constellation devices ( $C_i, i=1 \div n$ ) within device (P) communication range.

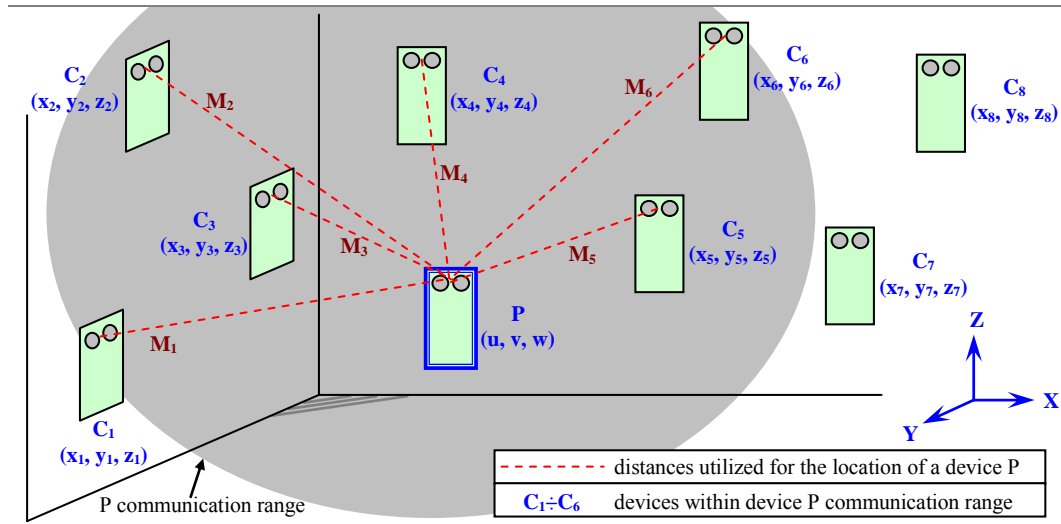

**Fig. 2.7.** Location of a generic device P

Each of the two Cricket mounted on the mobile probe locates its own position using the known locations of at least four constellation Crickets, and the measured distance from them. All information needed for the location is sent to a PC, for a centralized computing.

#### 2.4.2 Location of points touched by the probe tip

The probe tip (V) lies on the same line of devices A and B (see Fig. 2.5). This line can be univocally determined knowing coordinates of points  $A \equiv (x_A, y_A, z_A)$  and  $B \equiv (x_B, y_B, z_B)$ , and their distance  $d(A-V)$ .

The parametric equation of this line is:



$$\begin{cases} x = x_A + (x_B - x_A) \cdot t \\ y = y_A + (y_B - y_A) \cdot t \\ z = z_A + (z_B - z_A) \cdot t \end{cases} \quad (2.5)$$

The distance  $d(A-V)$  can be expressed as:

$$d(A-V) = \sqrt{(x_A - x_v)^2 + (y_A - y_v)^2 + (z_A - z_v)^2} \quad (2.6)$$

Coordinates of point  $V \equiv (x_v, y_v, z_v)$  are univocally determined solving a system of 4 equations in 4 unknown values ( $x_v, y_v, z_v$ , and  $t_v$ ):

$$\begin{cases} x_v = x_A + (x_B - x_A) \cdot t_v \\ y_v = y_A + (y_B - y_A) \cdot t_v \\ z_v = z_A + (z_B - z_A) \cdot t_v \\ d(A-V) = \sqrt{(x_A - x_v)^2 + (y_A - y_v)^2 + (z_A - z_v)^2} \end{cases} \quad (2.7)$$

Replacing terms  $x_v, y_v, z_v$  in the fourth equation:

$$d(A-V) = \sqrt{[x_A - x_A + (x_B - x_A) \cdot t_v]^2 + [y_A - y_A + (y_B - y_A) \cdot t_v]^2 + [z_A - z_A + (z_B - z_A) \cdot t_v]^2} \quad (2.8)$$

Then:

$$t_v = \frac{d(A-V)}{\sqrt{(x_A - x_B)^2 + (y_A - y_B)^2 + (z_A - z_B)^2}} = \frac{d(A-V)}{d(A-B)} \quad (2.9)$$

The denominator of Eq. 2.9 is the distance  $d(A-B)$  between the two Cricket devices installed on the mobile probe.

In conclusion, coordinates of the point  $V$  can be calculated as:

$$\begin{cases} x_v = x_A + (x_B - x_A) \cdot \frac{d(A-V)}{d(A-B)} \\ y_v = y_A + (y_B - y_A) \cdot \frac{d(A-V)}{d(A-B)} \\ z_v = z_A + (z_B - z_A) \cdot \frac{d(A-V)}{d(A-B)} \end{cases} \quad (2.10)$$

Eq. 2.10 univocally locates the point  $V$  using spatial coordinates of Crickets  $A$  and  $B$ . Distances  $d(A-B)$  and  $d(A-V)$  are *a priori* known as they depend on the probe geometry.

The previous model is based on the assumption that US sensors (A and B) and probe tip (V) are punctiform geometric elements. In practice, the model is inevitably approximated because sensors A and B have non punctiform dimensions (see Fig. 2.5). To minimize point P position uncertainty, the following condition should be approached:  $d(B-V) \ll d(A-V)$  [Zakrzewski, 2003].

### 2.4.3 Cricket firmware

Firmware is essential to organize RF and US communication among Cricket devices. Firmware is written in NesC language, and works under the operating system TinyOS. NesC is derived from C and it is currently utilized to program MICA Mote devices (produced by Crossbow Technologies), which Crickets are derived from. NesC is *object-oriented* and *event-based*. Programs are organized in independent modules. They interrelate themselves by means of reciprocal queries/replies [MIT C.S.A.I.L., 2004; Moore et al., 2004].

Fig. 2.8 shows a schematic flow-chart of Cricket firmware.

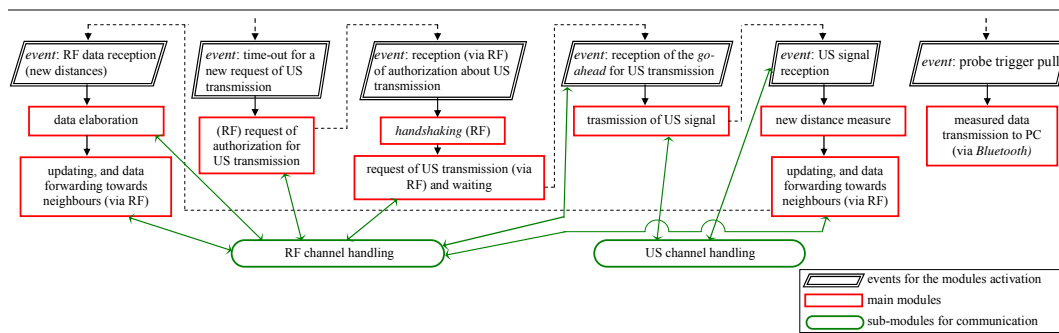

**Fig. 2.8.** A schematic flow-chart of the Cricket firmware

Each Cricket device performs two types of operations:

- time of flight measurement of US signals transmitted/received from other devices. At random time intervals, included between 150 and 350 milliseconds, each device tries to synchronize itself with neighbours, in order to exchange US signals. Synchronization information is transmitted through RF packets.
- when a Cricket receives a new distance – from a neighbour, or directly measured – stores and sends it to its neighbours by a RF packet containing a new list of inter-node distances.

Firmware coordinates the communication among Cricket devices, making them able to cooperate and share information about inter-node distances. When the user pulls the mobile probe trigger, all information is sent (via Bluetooth) to a PC for elaborations.

#### 2.4.4 Semi-automatic location of the constellation

Location of Cricket devices should be fast and automated as much as possible. This operation – if manually performed – is tedious and conflicting with system adaptability to different working places. As a consequence – in order to minimize human moderation – a method for a semi-automatic localization has been implemented. It is important to remark that accuracy in the localization of constellation nodes is fundamental for accuracy in the next mobile probe location. The more Crickets position are affected by uncertainty, the less the following measurements will be accurate [Taylor et al., 2005; Franceschini et al., 2008-I; Patwari et al., 2005; Sottile and Spirito, 2005; Mahajan and Figueroa, 1999].

Two techniques for the location of constellation devices were designed.

##### **1st approach**

First technique consists in touching (using the mobile probe) different reference points within measuring area. It is good to select points that are easily reachable and easy to be manually located in a reference coordinate system. For example, points laying on objects with a simple and known geometry (like parallelepiped vertexes). Spatial coordinates ( $x_i$ ,  $y_i$ ,  $z_i$ ) of the distributed constellation devices are the unknown parameters of the problem. Location of each device is performed using a trilateration. To identify a new device it is necessary knowing distances from at least 4 reference points [Chen et al., 2003]. Fig. 2.9-a represents the procedure to determine distances from some reference points and a constellation Cricket. The probe tip is placed next to the point  $P_2$ , with the aim of calculating the distance from Cricket B4 (point D). The following distances are known:

- AD and BD from constellation Cricket B4 and devices A and B;
- AB and  $P_2B$  from devices A and B – mounted on the mobile probe – and from the device B and the probe tip ( $P_2$ ).

To calculate distance  $P_2D$ , we can use Carnot Theorem (see Fig. 2.9-b). Applying this theorem to triangle ABD, we obtain the following equation:

$$AD^2 = AB^2 + BD^2 - 2 \cdot AB \cdot BD \cdot \cos(\alpha) \quad (2.11)$$

from which:

$$\cos(\alpha) = \frac{AB^2 + BD^2 - AD^2}{2 \cdot AB \cdot BD} \quad (2.12)$$

applying again Carnot theorem to triangle  $P_2BD$ :

$$P_2D^2 = P_2B^2 + BD^2 - 2 \cdot P_2B \cdot BD \cdot \cos(\alpha) \quad (2.13)$$

Combining Eq. 2.12 with Eq. 2.13 we obtain:

$$P_2D = \sqrt{P_2B^2 + BD^2 - P_2B \cdot \frac{AB^2 + BD^2 - AD^2}{AB}} \quad (2.14)$$

Eq. 2.14 makes it possible to calculate the distance from the reference point  $P_2$  to the constellation device  $B_4$  (point  $D$ ).

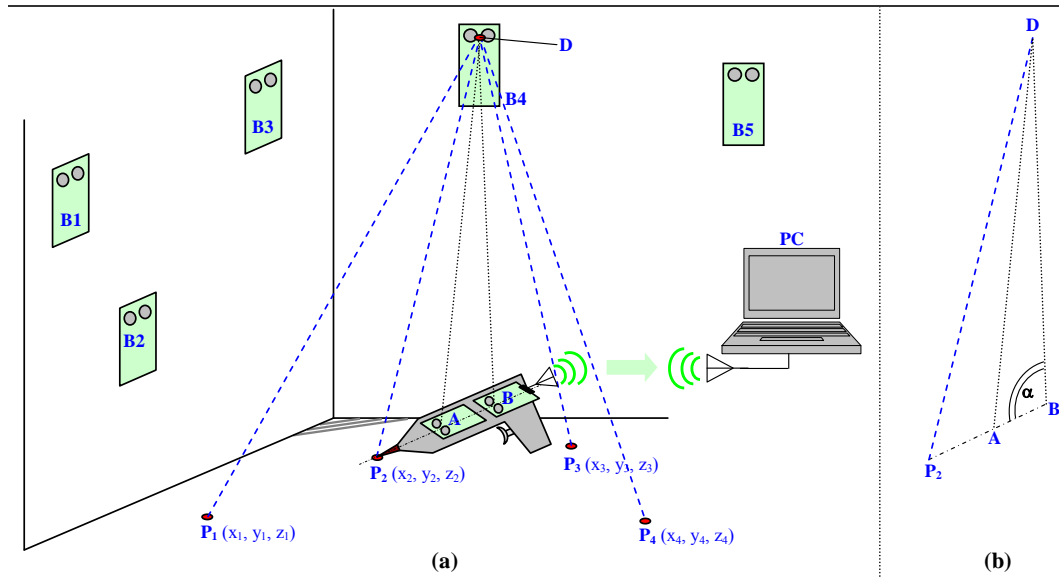

**Fig. 2.9.** Location of constellation device  $B_4$ , utilising distances from the reference points  $P_1$ ,  $P_2$ ,  $P_3$ ,  $P_4$

The described procedure is repeated for all reference points (i.e.  $P_1 \div P_4$  in Fig. 2.9). Once all required distances have been taken, a trilateration technique can be applied in order to localize each constellation Cricket.

The acquisition procedure is driven by an *ad hoc* software routine. Calculations are automatically performed by the central PC.

### 2nd approach

Second approach is an extension of the first. Previous localization approach is not adequate for constellations with a large number of Crickets, since each device needs knowing distances from at least 4 reference points. For that reason, we have implemented a semi-automatic localization technique, which also uses the information on the mutual distances among constellation Crickets. This technique is based on two steps:

- As described for the first approach, the mobile probe is used to touch 4 reference points in order to locate 5 constellation Crickets.

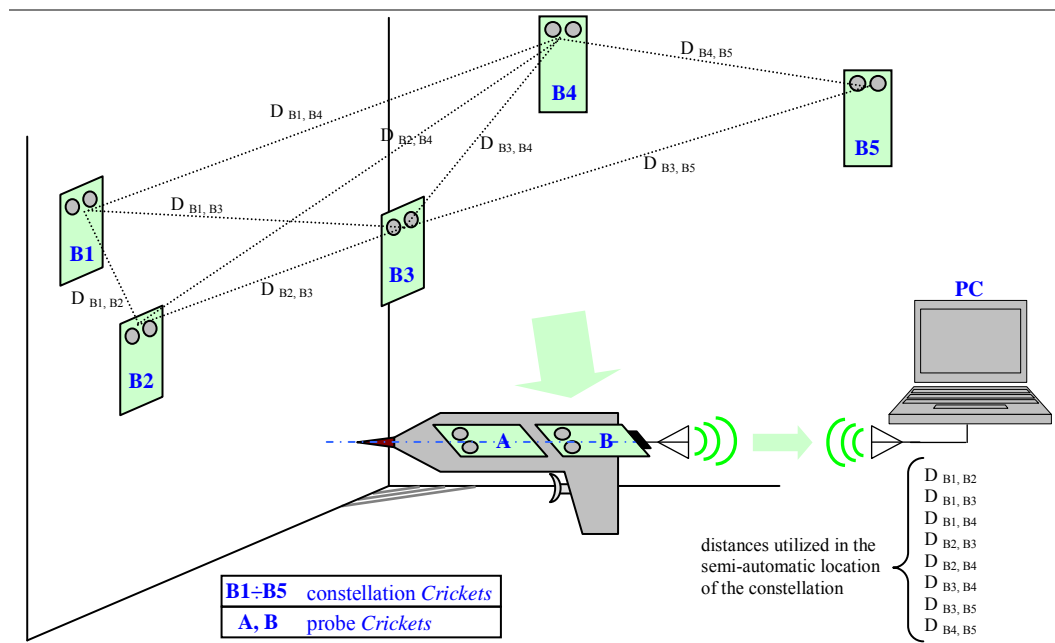

**Fig. 2.10.** Constellation location using the mobile probe as a “ear”

- Subsequently, the mobile probe is used as a “ear”, to receive the mutual distances of all the constellation Crickets (including the 5 which have been located). Signal gathered are sent to the PC (see Fig. 2.10). This information – combined with the information on the 5 located Crickets – is used to locate the whole constellation, by means of an “incremental” algorithm [Moore et al., 2004]. This algorithm starts with a set of 5 nodes with known coordinates. Other nodes in the network determine their own coordinates using distances from them. As an unknown node obtains an acceptable position estimate, it may serve as a new reference point. This process can be incrementally applied until all nodes in the network obtain their specific coordinates.

The procedure is driven by an *ad hoc* software routine. Time required for self-localization is about 1-2 minutes. Calculations are automatically performed by the central PC.



### 3. MScMS prototype

#### 3.1 Introduction

The first part of the chapter describes the features of the first MScMS prototype, developed at the Industrial Metrology and Quality Laboratory of DISPEA – Politecnico di Torino. Then, the results of practical tests to evaluate the system metrological performance are presented. Finally, MScMS critical aspects and possible improvements are discussed.

#### 3.2 Description of the first MScMS prototype

The first prototype of MScMS is made by the following elements:

- *Cricket constellation.* 22 Cricket devices have been freely distributed around a measuring area, covering a volume of about  $60 \text{ m}^3$ . To make their positioning easy, we used different supports, such as booms, articulated arms and tripods (see Fig. 3.1).

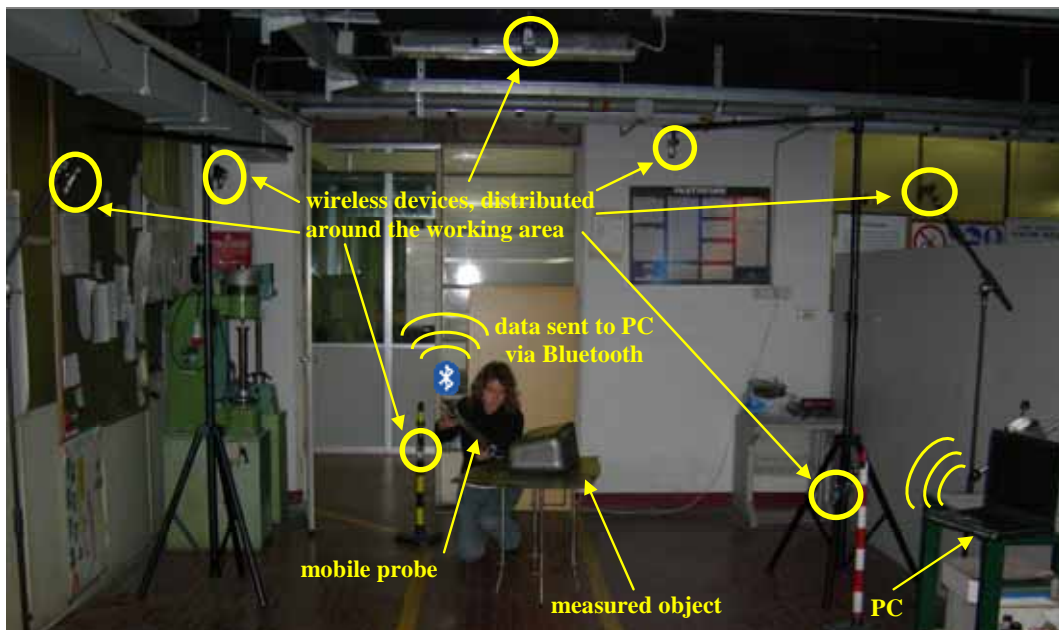
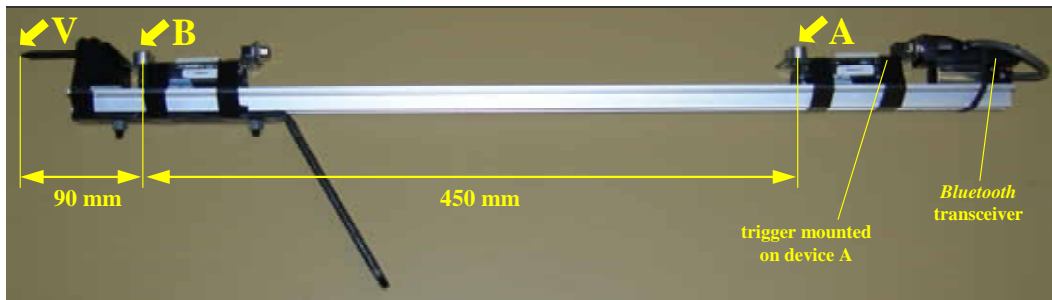

Fig. 3.1. Practical application of MScMS



- *Mobile probe.* It is made by a rigid structure containing the following elements:
  - two Cricket devices;
  - a tip to “touch” the points of measured objects. Tip (V) and Cricket devices (A and B) are aligned and spaced as indicated:  $d(A-B) = 450 \text{ mm}$  e  $d(A-V) = 540 \text{ mm}$  (see Fig. 3.2);
  - a Bluetooth transceiver connected with one of the two Cricket devices, by a RS232 serial port.



**Fig. 3.2.** Mobile probe prototype

- *Personal computer.* An *ad hoc* application software runs on a standard PC. To receive data sent by the probe, the PC is equipped with a Bluetooth transceiver.
- *Application software.* The purpose of this software is to drive the user through measurements and to make results display efficient. Functions provided are similar to those typically implemented by CMM software packages. MScMS, likewise CMMs, makes it possible to determine the shape/geometry of objects (circumferences, cylinders, plans, cones, spheres etc..), on the basis of a set of measured surface points gathered from the mobile-probe, using classical optimization algorithms [Overmars, 1997].

More in detail, the software is organized into three application modules to assist the user in the following operations:

- *Initialization.* This is a guided procedure to switch on wireless devices (Cricket and Bluetooth adapter), and open the PC connection for data reception from the mobile probe.
- *Semi-automatic localization of the constellation.* This procedure is described in Section 2.4.4.

- *Measurements*. Execution of different kinds of measurement: single points measurements, distance measurements, curves and surfaces evaluation (see Fig. 3.4 and Fig. 3.5).

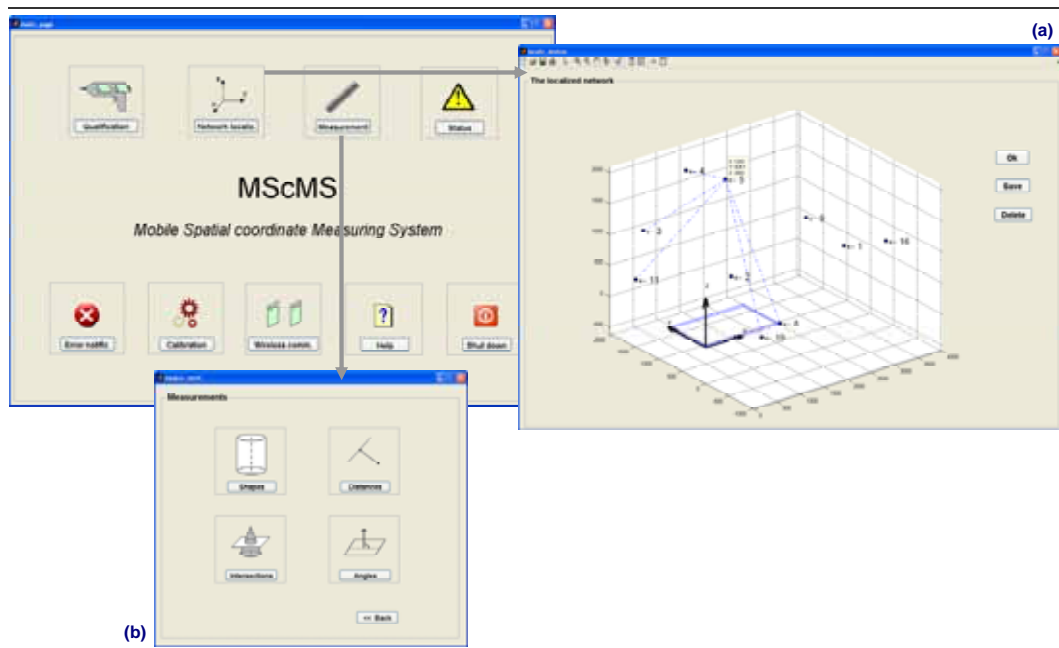

**Fig. 3.3.** MScMS software menu

Fig. 3.3, Fig. 3.4 and Fig. 3.5 show some displays of the MScMS software.

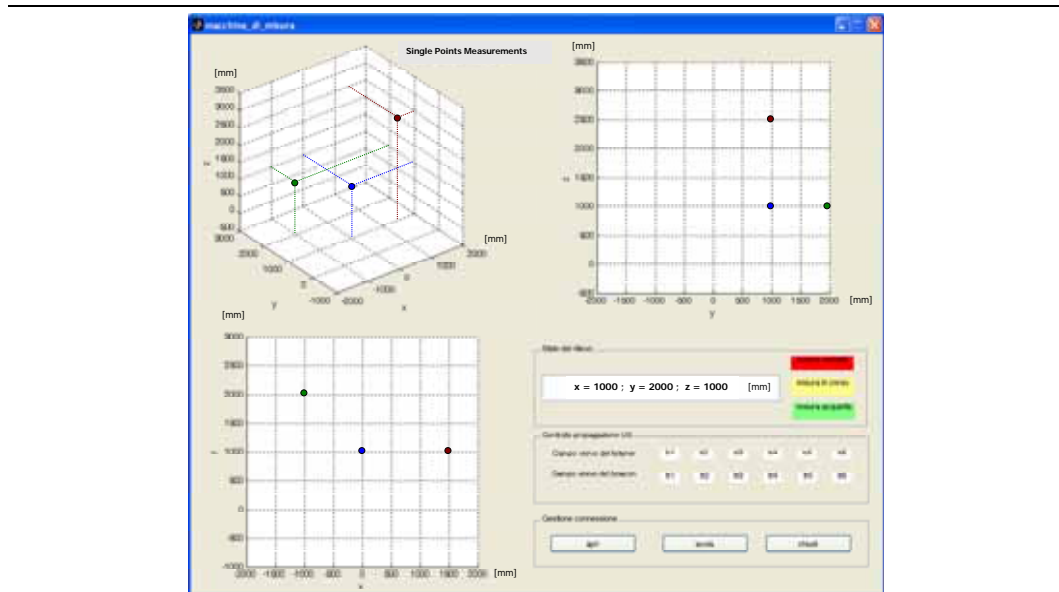

**Fig. 3.4.** Display for the measurement of single points

Measurements are taken like this: when the probe trigger is pulled, the application software calculates Cartesian coordinates of the point touched by the probe tip. If measurement is correctly taken, an acoustic signal is emitted. Measure results are displayed using numeric and graphical representations. Fig. 3.3 shows some screenshots of the software main menu and sub-menus.

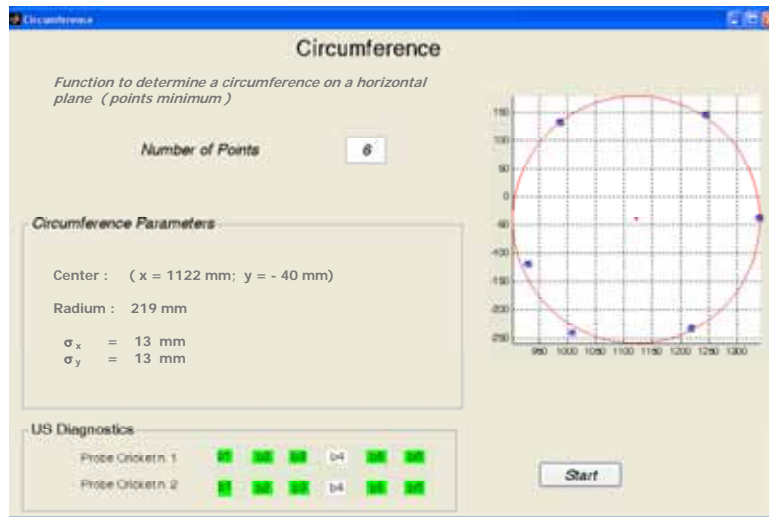

Fig. 3.5. Display for the measurement of a circle

### 3.3 MScMS actual performance, critical aspects and possible improvements

A preliminary prototype of MScMS has been set-up and tested, with the purpose of verifying system feasibility and to evaluate its performance. The prototype actual performance has been estimated carrying out two practical tests:

- *Repeatability test.* Repeatability is defined as: "closeness of the agreement between the results of successive measurements of the same measurand, carried out under the same conditions of measurement" [GUM, 2004; VIM, 2004]. In this test, a single point within the working volume is measured repeating the measurement about 50 times, leaving the mobile-probe in a fixed position (see Fig. 3.6-a). The test is repeated measuring at least 20 different points in different areas of the working volume. For each point, we have calculated the standard deviations ( $\sigma_x$ ,  $\sigma_y$ ,  $\sigma_z$ ) related to the registered Cartesian coordinates ( $x$ ,  $y$ ,  $z$ ).

- *Reproducibility test.* Reproducibility is defined as: “closeness of the agreement between the results of successive measurements of the same measurand, carried out under changed conditions of measurement” [GUM, 2004; VIM, 2004]. This test is similar to the previous one, with the only difference that the mobile-probe orientation is changed before each measurement, with the aim of approaching each (single) point from a different direction (see Fig. 3.6-b).

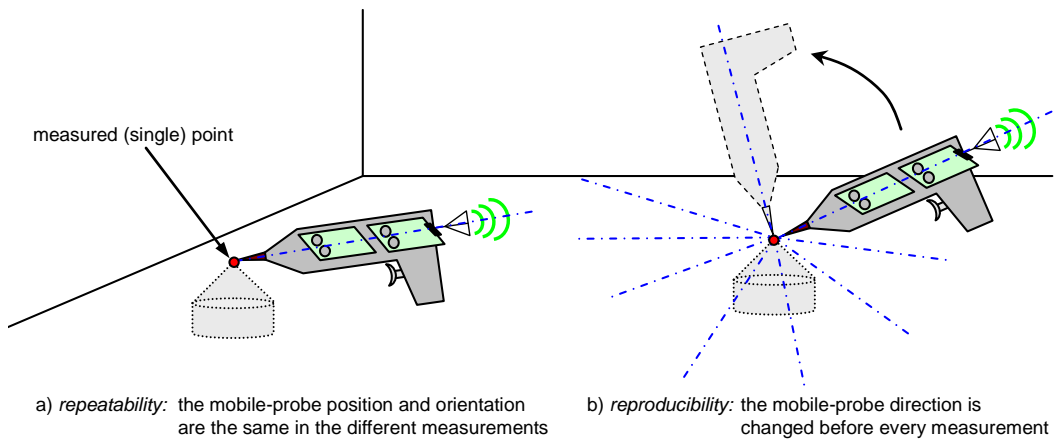

**Fig. 3.6.** Representation scheme of the practical tests carried out to evaluate MScMS performances

The statistical results of these preliminary tests are reported in Tab. 3.1.

**Tab. 3.1.** Results of the MScMS preliminary tests

Test	<i>repeatability</i>			<i>reproducibility</i>		
	$\sigma_x$	$\sigma_y$	$\sigma_z$	$\sigma_x$	$\sigma_y$	$\sigma_z$
Mean standard deviation [mm]	4.8	5.1	3.5	7.3	7.8	4.1

Let notice that  $\sigma_z$  value is basically lower than  $\sigma_x$  and  $\sigma_y$ , both for repeatability and reproducibility tests. This behaviour is due to the geometric configuration of the constellation devices: in general, network devices are mounted on the ceiling or at the top of the measuring area; for this reason, they can be considered as approximately placed on a plane (XY) perpendicular to the vertical (Z) axis (see Fig. 3.1).

Since we have experimentally verified that the distribution of the point coordinates can be considered to be normal, both for repeatability and reproducibility data, the variability range, considering a 99.73% confidence level, is given by  $\pm 3\sigma$  [Montgomery, 2008].

Reproducibility range is an index of the instrument actual accuracy, whereas repeatability variation range is an index of the target instrument accuracy, supposing to compensate the most important causes of systematic errors.

The most critical aspects of the whole measuring system are due to US sensors. In particular:

1. Dimensions of US transceivers;
2. Different types of noise affecting US signals;
3. Speed of sound dependence on environmental conditions;
4. Working volume discontinuities;
5. Use of amplitude threshold detection at receivers.

These aspects are individually discussed in the following subsections.

### ***Dimensions of US transceivers***

A source of uncertainty in US time-of-flight measurements is due to non punctiform US sensors. The volume of each piezo-electric crystal is about  $1 \text{ cm}^3$ . As shown in Fig. 3.7, it is difficult to determine the exact point of departure/arrival of a US signal exchanged between a pair of Crickets. These points are placed on the US sensors surfaces, and may vary depending on their relative position.

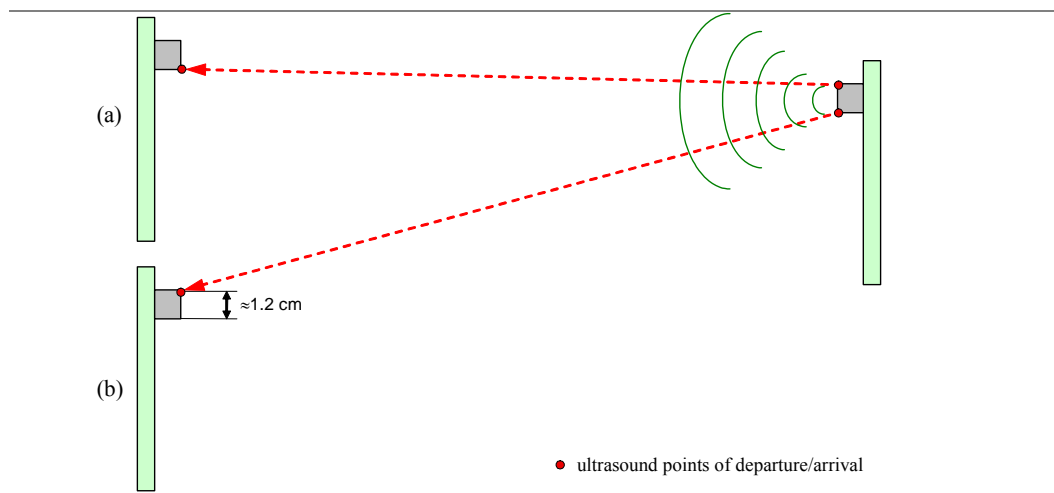

**Fig. 3.7.** Points of departure/arrival of US exchanged between 2 Crickets

Regarding the future, Cricket devices will be modified in order to minimize this problem, for example by miniaturizing the US sensors.

### ***Different types of noise affecting US signal***

During measurements, the user should not obstruct US signal propagation. Two possible drawbacks may occur:

- transmitted US signal does not reach the receiver because it is completely shielded by an obstacle;
- transmitted US signal *diffracts* and goes round the interposed obstacle, reaching the receiver. In this case, path covered by US is longer than the real distance between transmitter and receiver (see Fig. 3.8).

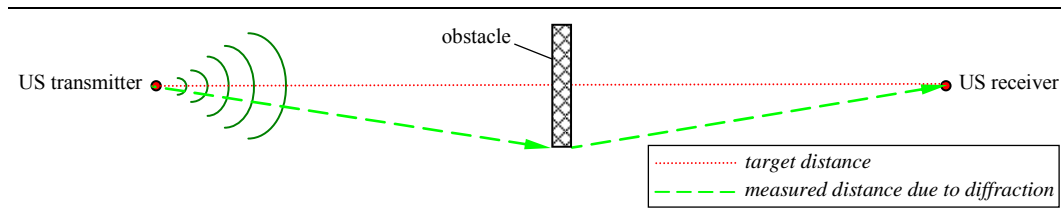

**Fig. 3.8.** US diffraction

The second case is more complicated to manage than the first. In general, it is not easy to notice possible path deflections. Probe can be prone to other types of noise, like external sources of US. For example, US produced by metal objects jingling. However, wrong distance measurements, like the ones described, can be indirectly detected and rejected. To that purpose, an effective diagnostic tool is the Error Function (EF, see Eq. 2.4) [Franceschini et al., 2002; Franceschini et al., 2007-II]. This function, evaluated during the localization of both the mobile-probe devices (A and B), is an index of the bias between measured distances (evaluated by means of US transceivers) and calculated distances (determined on the basis of the localised position). We have experimentally verified that the minimum value of the EF is generally of the order of the tenth of  $\text{mm}^2$ . When one or more measured distances are wrong – due to systematic effects – the EF minimum value “explodes” becoming 3 or 4 orders of magnitude greater. In practical terms, during the location of devices A and B, if the EF minimum is included below a threshold value (say  $70 \text{ mm}^2$ ), then the position is considered to be reasonable. Otherwise, it is rejected.

### ***Speed of sound dependence on environmental conditions***

Speed of sound ( $s$ ) value makes it possible to turn US time of flight into a distance (Eq. 2.2). It is well known that the speed of sound changes with air conditions – temperature and humidity – which can exhibit both temporal and spatial variations within large working volumes. As a consequence, ( $s$ ) requires to be often updated, depending on the time and the position. A partial solution to this problem is to use the temperature ( $T$ ) information evaluated by embedded thermometers at the Cricket receivers and to periodically up-

date ( $s$ ) using an experimental relation  $s = s(T)$  [Bohn, 1988]. As a better alternative, we implemented an optimization procedure which makes it possible to estimate, measurement by measurement, the optimum ( $s$ ) value, using the following information:

- times of flight among (at least) 4 constellation Crickets and the 2 mobile-probe Crickets (A and B);
- a standard of length for referability, given by the *a priori* known distance between the mobile-probe Crickets (A and B).

By an automatic optimization, we calculate the ( $s$ ) value which better satisfies the previous constraints, with reference to a particular portion of the working volume. In this way, the ( $s$ ) value can be recalculated for each single measurement.

### **Working volume discontinuities**

A requirement of the measuring instruments is to measure uniformly and with no discontinuities all the points within the working volume. Due to its technology, MScMS is based on a network of distributed devices, communicating through RF and US. While RF sensors communication range is almost omni-directional and up to 25 m, US sensors have a communication range limited by “cones of vision” with an opening angle of about  $170^\circ$  and a range of no more than 6-8 m (see Fig. 3.9). Signal strength outside the cones drops to 1% of the maximum value (see the radiation pattern in Fig. 4.3) [Priyantha et al., 2000].

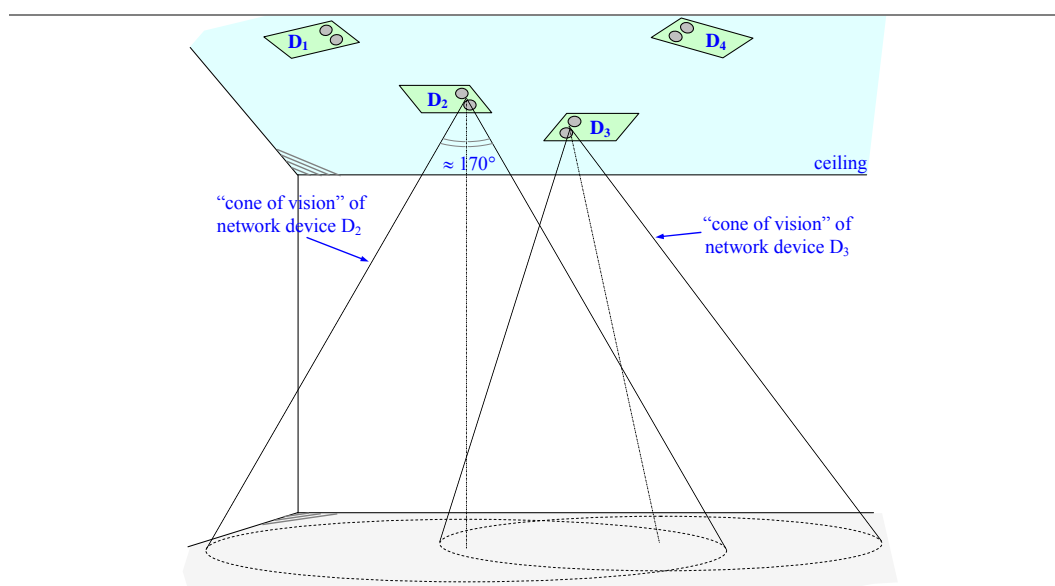

**Fig. 3.9.** Representation scheme of the US sensors "cones of vision"

It is therefore important to provide a full coverage to the area served by constellation devices by proper alignment of the US transmitters towards the measuring area. To increase the working volume coverage it is necessary to increase the number of constellation devices. In general, the best solution is mounting the constellation devices on the ceiling or at the top of the measuring area, as shown in Fig. 3.1.

On the basis of practical tests, we determined that the coverage of a indoor working volume about 4 meters high can be achieved using about one constellation device per square meter (considering a plant layout).

#### ***Use of amplitude threshold detection at receivers***

To evaluate time-of-flight (TOF), receivers can detect signals with amplitude equal or greater than a threshold value. Since US transceivers operate at 40 kHz frequency, the time period of a complete wave cycle is  $1/40,000 \text{ s} = 25 \text{ }\mu\text{s}$ . US waves are saw-tooth shaped, with a linear rise (see Fig. 3.10).

Considering fresh US signals at the transmitter, their amplitude may decrease depending on two basic factors:

- *(distance) attenuation*: signal amplitude decreases depending on the distance covered.
- *transmitter orientation*: since US transmitters are not omni-directional, signal amplitude changes depending on their orientation. In particular, the maximum signal strength is related to the direction perpendicular to the transducer surface (at the axis of the "cone of vision"), while signal amplitude drops to 1% of the maximum value at  $\pm 40^\circ$  away from it (see Fig. 3.3) [Priyantha et al., 2000].

The consequence of the use of amplitude threshold detection is the occurrence of errors in TOF evaluation. The implementation of the threshold detection method at the receivers is a source of inaccuracy. As represented in Fig. 3.10 and Fig. 4.4, the signal transient time at the receiver strongly influences the ranging precision. This may cause relatively large errors in the TOF evaluation (one or more US time periods).

Actually, since the speed of sound is about 340 m/s, one US time period corresponds to a distance of about 8.5 mm. Considering that the threshold can be exceeded even 4 period late, distance overestimation can be up to 3÷4 cm!



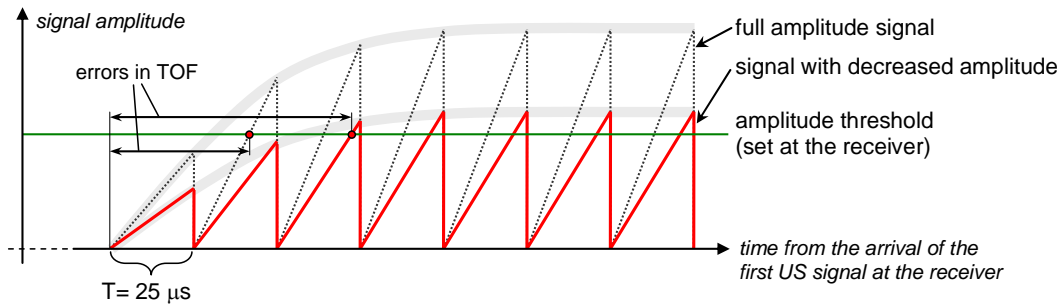

**Fig. 3.10.** Representation scheme of the error produced by the use of amplitude threshold detection method. The signal transient time at the receiver strongly influences the ranging precision

### 3.4 Final considerations

MScMS first prototype is adaptable to different working environments and does not require long installation or start-up times. Before performing measurements, constellation devices – freely distributed around the measuring area – automatically locate themselves in few minutes. System is supported by an *ad hoc* software – created in Matlab – to drive the user through measurements and online/offline elaborations.

Today, MScMS Achilles' heel is represented by its low accuracy (few centimetres) related to the measured points position. This is mainly due to the use of US transceivers (implementation of the threshold signal detection method, non punctiform dimension, speed of sound dependence on temperature etc..). As research perspectives, all factors affecting system accuracy will be analysed and improved in detail, in order to reduce their effect.

## **4. Experimental evaluation of the MScMS ultrasound transducers**

### **4.1 Introduction**

Ultrasonic (US) sensors are used in many application fields. In general, the main features of ultrasound transducers change depending on the propagation medium (solids, liquids, air). One of the most important applications of US transducers is distance measurement, where the propagation medium of the acoustic signals is typically air. Common applications associated with distance measurement are presence detection, identification of objects, measurement of the shape and the orientation of workpieces, collision avoidance, room surveillance, liquid level and flow measurement [Delpaut et al., 1986]. Ultrasonic ranging systems are traditionally low cost, compared to other technologies like the optical laser based. Unfortunately, they are also characterized by low accuracy, low reliability due to reflections of the transmitted signals, and limited range [Manthey et al., 1991]. US sensors provide high accuracy only in certain working contexts. Excellent performances can be achieved when measuring for example short, fixed distances and controlling environmental conditions (temperature and humidity). The most common technique for distance evaluation is by measuring the time-of-flight (TOF) of the US signal – either from a transmitter to a receiver or using a single transceiver, which transmits the US signal and receives the corresponding reflected signal. Other aspects influencing the performance of ultrasonic sensors are the type of transducers and the signal detection method used (i.e. thresholding, envelope peak, phase detection – discussed in Section 4.2). For this reason, different types of transducers can be employed depending on the specific application. Most of commercially available air ultrasonic transducers are ceramic based and operate at 40 kHz. Transducers that operate at higher frequencies, such as at 200 kHz, are more limited and more expensive [Toda, Dahl, 2006].

This chapter focuses on the US transducers used by the Mobile Spatial coordinate Measuring System (MScMS). The characterization of the MScMS' US transceiver is performed by means of several experiments, organically designed through a factorial

plan, and performed in different measuring conditions. Particular emphasis is given to the effect of the US signal attenuation on the TOF estimation. Also, the major sources of errors in TOF evaluation are investigated in a structured way, by means of an experimental factorial plan. The results of this analysis can be useful to identify the major MScMS sources of inaccuracy and to determine how the error in TOF evaluation changes in the different points within the Cricket transmitters' "cones of vision" (see Fig. 3.9).

The chapter is organised in four sections. Section 4.2 describes the main features of piezo-electric US transceivers, like those equipping MScMS. Section 4.3 provides a detailed description of the factorial plan, analysing the effects and the possible interactions of the sources of attenuation. Section 4.4 presents and discusses the results of the factorial plan. Finally, the conclusions and future direction of this research are given in Section 4.5.

## 4.2 Piezo-electric US transducers

In modern ultrasonic distance measurement systems for industrial applications, piezo-electric transducers clearly dominate. Typical advantages are their compact, rugged mechanical design, high efficiency, great range of operation temperature and relatively low cost. Airborne ultrasound systems have been developed for many types of distance measurement using two possible techniques [Berners et al., 1995]:

- *pulse-echo*: a transducer emits a burst of US, which bounces off any object in the path of the beam. The transducer then acts as a receiver for the reflected signal. A measurement of the time delay from transmission to reception determines the distance to the target.
- *time-of-flight*: a separate transmitter is pointed towards the receiver. Instead of relying on reflections, this system detects the direct transmission of the signal from transmitter to receiver. After measuring the TOF, the sensors distance can be calculated knowing the speed of sound value.

Cricket devices, being equipped with either a US transmitter and a receiver, implement the TOF technique.

A complex problem when using US transducers is the choice of the characteristic parameters (typically, resonant frequency and bandwidth). For distance measurement with relatively high precision (few millimetres), transducers with a wide bandwidth are

needed. Bandwidth is a measure of how rapidly a signal reaches the steady state. A signal at the receiver – obtained from transducers with a small bandwidth – climbs slowly from its beginning to its peak in time-domain, causing a relatively large transient time at the receiver. This behaviour is shown in Fig. 7 [Cheng, Chang, 2007; Tong et al. 2004].

A second factor affecting measurement accuracy is the transducer resonant frequency. With increasing frequency (and thus reducing wavelength) a better resolution is achievable. Unfortunately, both the transducer bandwidth and resonant frequency are directly correlated with the US attenuation and – consequently – they limit the detection range. In other terms, considering the same US signal amplitude, the radiated signal amplitude at a given distance from the transmitter becomes smaller if its bandwidth and resonant frequency increase [Tong et al., 2005; Kazys et al., 2007]. For this reason, the selection of ultrasonic frequency and bandwidth is a compromise between accuracy and detection range.

The piezo-electric transducer adopted by Cricket devices is a low-cost, general purpose model (Murata MA40S4R, see Fig. 4.1-a), with a relative wide bandwidth (see Fig. 4.1-b), in which the centre frequency is about 40kHz. This working frequency is a trade-off between accuracy (considering the single distances, it is around 1-2 centimetres) and detection range (up to 6-8 meters) [Balakrishnan et al., 2003].

The acoustic strength of the radiation from a flat transducer with “piston motion” (like the Crickets’ US transducers) is generally angle dependent because of the phase difference of waves from each point on the surface. Actually, the acoustic radiation is the integral sum of the waves from all points on the transmitter surface, and the propagation path difference from each point to a reference observation point has a phase cancellation effect which leads to signal attenuation [Lamancusa, Figueroa; 1990]. However, if the receiver is directly facing the transmitter at sufficient distance from it, the acoustic radiation from each point of the transducer surface does not have a phase-cancelling effect. This because the distance from an arbitrary point on the transmitter surface to the receiver becomes almost constant, and the difference is much smaller than the wavelength [Toda, 2002]. On the other hand, if the transmitter is misaligned with the receiver, the US signal amplitude will be attenuated because of the disruptive interference of the different US signals from the transmitter different surface points. This effect is represented by the simplified scheme in Fig. 4.2. This scheme considers the interaction of the waves from two points on the transducer surface; the same principle can be extended to all the surface points.

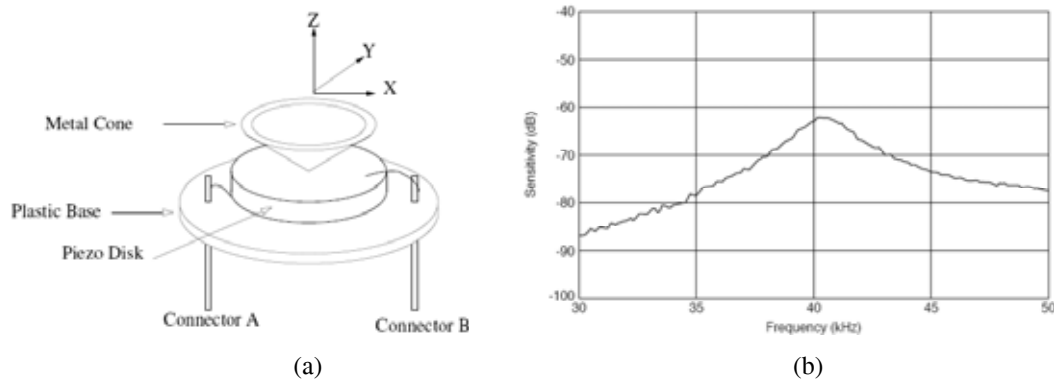

**Fig. 4.1.** (a) internal construction of a Murata MA40S4R piezo-electric ultrasonic transmitter/receiver. The dimensions of the piezo material causes the disk to resonate at a precise frequency (around 40kHz); (b) representation of the transmitter bandwidth by means of a frequency response plot

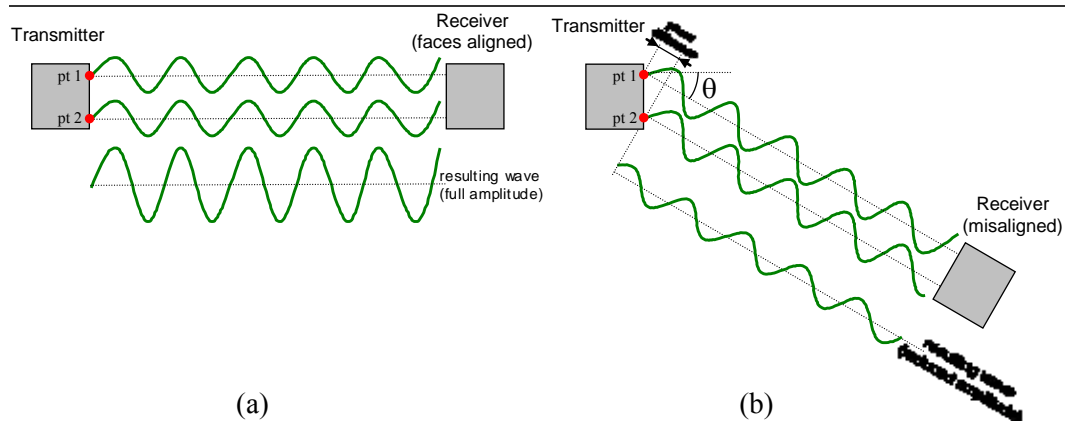

**Fig. 4.2.** US signal strength dependence on the transmitter angle ( $\theta$ ). The simplified scheme represents the interaction of the waves from 2 points on the transducer surface. The resulting wave is given by the sum of the single waves. If the receiver is directly facing the transmitter (case-a) the two individual waves are in-phase and the resulting wave amplitude has the maximum value. If the transmitter is misaligned with the receiver (case-b) the resulting wave is attenuated because of a phase cancelling effect due to the phase difference between the two individual waves [Lamancusa, Figueroa; 1990]

The resulting ultrasonic transmitter radiation pattern, depending on the transmitter misalignment angle with the receiver, is shown in Fig. 4.3. As represented, the transmitter US signal strength drops along directions that are away from the direction facing the ultrasonic transducer.

Similarly, the received signal strength can be influenced by the receiver orientation. In particular, considering the same signal strength from the transmitter, the received signal strength is maximum when the receiver's surface is facing the transmitter. On the other hand, the received signal decreases when the receiver's surface is angled.

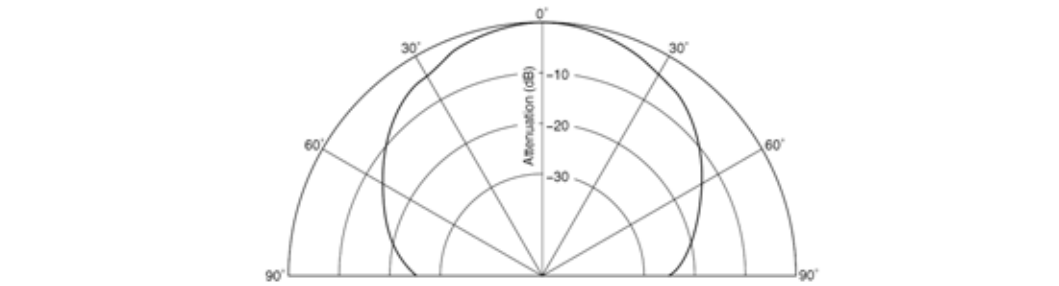

**Fig. 4.3.** The radiation pattern of the Cricket ultrasonic transducer on a plane along its axis, depending on the orientation. Signal strength drops along direction that are away from the normal direction to the transducer surface

Several signal methods have been developed for detecting US signals:

*Thresholding.* It is the simplest and the most widely used, and applies to any type of short duration signal. By this method, implemented by Cricket devices, the receiver electric output signal is compared with a threshold level (65 mV for Cricket devices), such that arrival of the wave is acknowledged when the signal reaches this level. This method depends on the amplitude of the pulse received: the larger the signal amplitude, the smaller the time taken by the signal before reaching the threshold. Considering the example in Fig. 4.4, when the signal has a full amplitude, the detection threshold is first exceeded by the second peak of the US waveform. When the waveform is attenuated by a factor of 0.5 (half amplitude signal), the detection threshold is first exceeded by the third peak of the US waveform. If the channel attenuation is quite significant, it may cause the threshold to be exceeded a few periods late, instead of just one period late. Considering that, for a 40kHz US a period is 25  $\mu$ s, this error will approximately be in integer multiples of 25 $\mu$ s. Since the speed of sound is around 340 m/s, a one period error corresponds to a  $25 \cdot 340 / 1000 = 8.5$  mm distance overestimation. In practice, since the threshold can be exceeded even 4 period late, distance overestimation can be up to 3÷4 cm!

*Envelope peak detection.* It is a modification of thresholding, which may be called adjustable thresholding. This method acknowledges arrival of the signal when a maximum amplitude is detected. Therefore, it does not depend upon the absolute magnitude of the pulse, but only upon its shape. As a consequence it is more accurate and robust than simple magnitude thresholding, where the acknowledge time can easily jump by one period.

*Phase-detection.* Other more refined ranging methods are based on phase detection with fixed-frequency signals and with frequency-modulated signals. These methods, however, requires complex hardware and software. They use a digital signal processor to process

the phase measurements and overcome the inherent range limitation of one wavelength [Manthey et al., 1991; Tong et al., 2001].

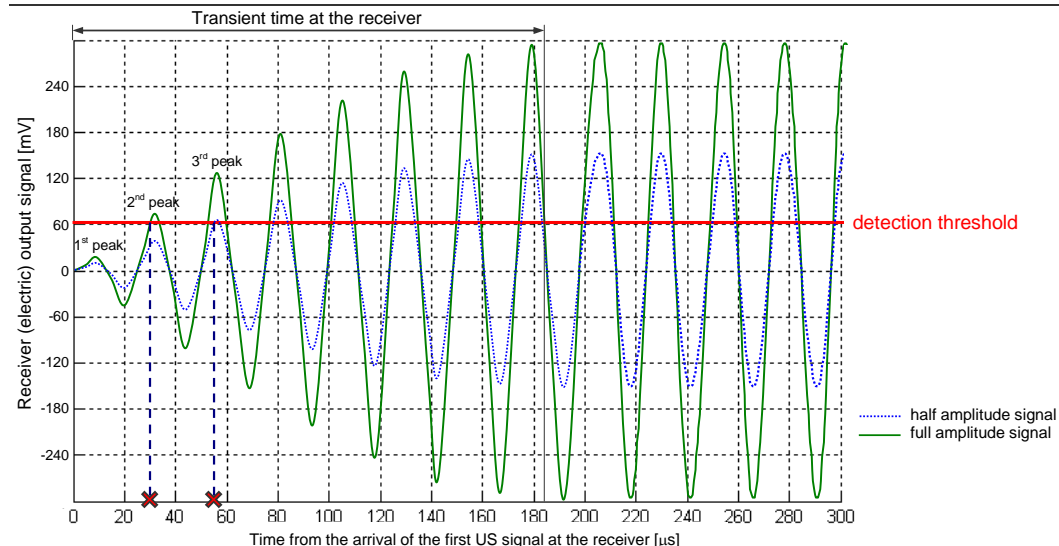

**Fig. 4.4.** Schematic representation of thresholding detection. A minimum number of cycles are necessary to bring the receiver to steady state conditions (transient time at the receiver) [Johansson et al., 2005]. The error in the distance measurement is dependent on the received US signal amplitude, because the time taken for the received signal to reach the threshold is dependent on it

### 4.3 Factors affecting US transceivers

MScMS measurement accuracy may change depending on many different factors related to the use of US transceivers, such as temperature, humidity, air turbulence, transducers geometry, transducer bandwidth, US signal attenuation etc. When implementing a thresholding detection method, the major effects are due to the factors related to the US signal attenuation. The most important sources of attenuation are [Franceschini et al., 2008-II; MIT C.S.A.I.L., 2004]:

- transceivers distance;
- transceivers misalignment angle;
- transducer battery charge level.

With the aim of organically investigating the effect of these factors on TOF measurements, a complete experimental factorial plan is built.

Fig. 4.5 shows a representation scheme of the experimental setup:

- transmitter and receiver are positioned facing each other;
- transceivers distance are positioned at known distance (1st factor);
- transmitter face is not perfectly aligned with receiver face. A misalignment angle ( $\theta$ ) with regard to the transmitter face is introduced (2nd factor). On the other hand, the receiver face is perpendicular to the US waves direction of propagation;
- transmitter battery charge level is monitored measuring the battery potential difference (3rd factor). Each Cricket is equipped with two AA rechargeable 2700 mAh batteries, connected in series. Their potential difference is measured by a standard voltmeter. The potential difference is not a direct measurement of the battery charge level, but – since they are correlated – it is an useful indicator of it [Franceschini et al., 2007-I].

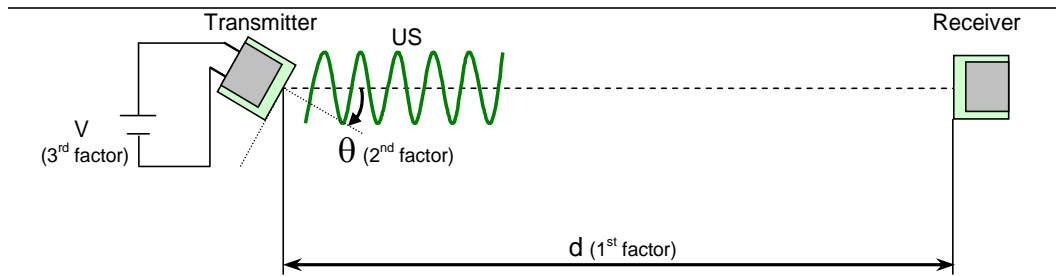

**Fig. 4.5.** Experimental setup

TOF is measured changing these 3 factors at different levels:

- Seven levels for  $\theta$  (transmitter rotations from  $0^\circ$  to  $60^\circ$  in  $10^\circ$  intervals). For larger angles, transmitter and receivers do not easily communicate, due to the strong decrease in the US signal strength (see Fig. 6).
- Three levels for  $d$ : short, medium and long distance between transceivers. These distances have been measured using 3 reference bars, accurately calibrated using a standard Coordinate Measuring Machine (accuracy lower than a hundredth of mm) [Furutani and Kamahora, 2001].
- Five levels for  $V$  (from 2.3V to 2.7 V in 0.1 V intervals).

Tab. 4.1 provides a summary of the combinations for the three factor levels.

There are  $7 \cdot 3 \cdot 5 = 105$  different combinations to be carried out. According to the factorial plans good practice, measurements are randomized [Montgomery, 2008]. For each of these combinations, 50 measurements of the TOF are performed. All the experiments



have been replicated 5 times. The total number of combinations analysed is  $105 \cdot 5 = 525$  (with 50 measurements per combination).

**Tab. 4.1.** List of the experiments on the Cricket's US transducers

Factors		
1 <sup>st</sup> – Transceivers distance (d)	2 <sup>nd</sup> – Transmitter misalignment angle ( $\theta$ )	3 <sup>rd</sup> – Battery level (V)
(Short) $d_1 = 1160$ mm	$\theta_1 = 0^\circ$	$V_1 = 2.7$ V
(Medium) $d_2 = 2034$ mm	$\theta_2 = 10^\circ$	$V_2 = 2.6$ V
	$\theta_3 = 20^\circ$	$V_3 = 2.5$ V
(Long) $d_3 = 3671$ mm	$\theta_4 = 30^\circ$	$V_4 = 2.4$ V
	$\theta_5 = 40^\circ$	$V_5 = 2.3$ V
	$\theta_6 = 50^\circ$	
	$\theta_7 = 60^\circ$	

- all the possible  $7 \cdot 3 \cdot 5 = 105$  different combinations are carried out in random order;  
- for each combination, TOF measurements are repeated 50 times and the average value is taken;  
- all the 105 combinations above are replicated 5 times. Consequently, the total number of combinations is 525.

The response variable considered in the factorial plan is the TOF error, defined as follows:

$$\text{TOF-Error} = (\text{Measured-TOF} - \text{Expected-TOF}) \quad (4.1)$$

being

- Measured-TOF: TOF measured by the couple of Cricket devices;
- Expected-TOF =  $d/s$ : where (d) is the transceivers known distance and (s) is the speed of sound in the experimental conditions. For example, with a temperature  $T=24^\circ\text{C}$  and a relative humidity  $\text{RH}=27\%$ , (s) is about 346 m/s.

TOF-Error is used as an indicator of the inaccuracy in TOF evaluation [Franceschini et al., 2007-I].

The experiments are performed in a controlled environment ( $T=24^\circ\text{C}$  and  $\text{RH}=27\%$ ) to prevent outlier distance measurements due to reflected ultrasonic signals or to variations in the environmental conditions.

#### 4.4 Analysis of the experimental results

Subsection 4.4.1 shows and discusses the results of the factorial plan. Subsection 4.4.2 summarizes them, providing theoretical interpretations of some important aspects. Sub-

section 4.4.3 presents other minor experiments, aimed at deepening the factorial plan analysis.

#### 4.4.1 Results of the factorial plan

Analysing the factorial plan experimental outputs, the first interesting result is that the TOF-Error standard deviation ( $\sigma$ ) changes depending on the TOF-Error value. In other words, the population of TOF-Error cannot be considered as homoscedastic, that is to say with a constant standard deviation.

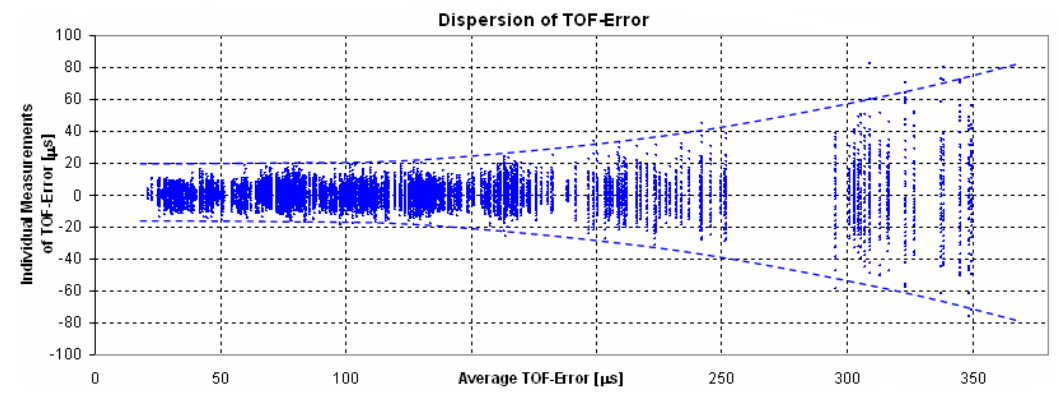

**Fig. 4.6.** TOF-Error standard deviation vs average TOF-Error. For each of the 525 factors combinations, variables are calculated using the corresponding 50 individual TOF-Error measurements.

This behaviour is well shown on Fig. 4.6, where for each of the 525 factorial plan combinations, the average TOF-Error and the respective standard deviation – calculated using the corresponding 50 individual measurements – are plotted. It can be noticed that the larger the average TOF-Error value, the larger the individual measurements dispersion. The non constancy of the TOF-Error variance is also tested through the Levene's statistical test.

Since the assumption of homogeneity of TOF-Error variances is violated, the Analysis of Variance (ANOVA) cannot be properly applied, in order to verify if factors have a significant effect on the response (TOF-Error) and if there are factor interactions [Montgomery, 2008]. The usual approach to dealing with nonconstant variance is to apply a *variance-stabilizing transformation*. In this approach, the conclusions of the analysis of variance will apply to the transformed populations. The most common transformation is the exponential  $y^* = y^\lambda$ , where  $\lambda$  is the parameter of the transformation. Box and Cox proposed an optimization method for determining the transformation parameter [Box et al.,

1978]. Once a value of  $\lambda$  is selected by the Box-Cox method, the experimenter can analyse the data using  $y$  as the transformed response (it will be identified hereafter as “corrected TOF-Error”). Considering the case of interest, we obtained  $\lambda=0.52$ . It was demonstrated through the Levene’s test, that the transformed response variance is now stabilized.

Of course, a problem is that it may be uncomfortable working with the transformed response ( $y^*$ ) in the transformed scale, since it can result in a nonsensical value over the factor space of interest. To construct a model in terms of the original response, the opposite change of variable –  $(y^*)^{\frac{1}{\lambda}}$  – is performed.

To have a first idea of the single examined factors effect on the TOF-Error, we use the Main Effects Plot (see Fig. 4.7). The points in the plot are the means of the response variable at the various levels of each factor (for each level of the examined factor, the mean is calculated averaging all the responses obtained changing the remaining two factors). A reference line is drawn at the grand mean of the response data. This kind of plot is useful for comparing magnitudes of main effects.

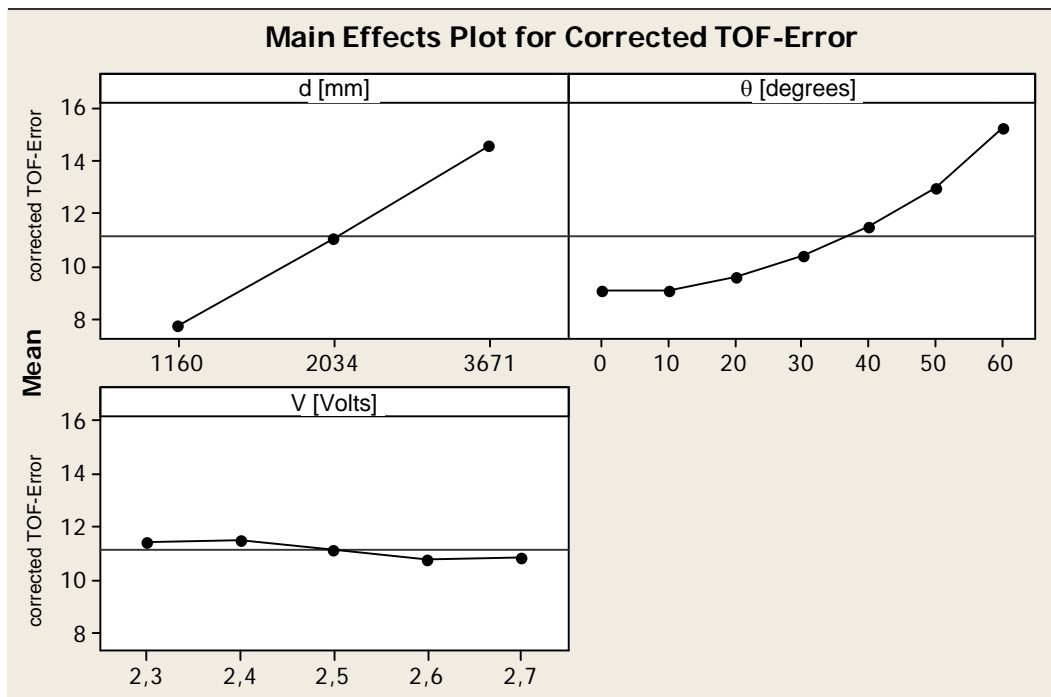

**Fig. 4.7.** Main effect plot for means, related to the three examined factors:  $\theta$  (misalignment angle),  $d$  (transceivers distance),  $V$  (batteries potential difference)

The qualitative result is that misalignment angle and transmitters distance have an important effect, while the effect of battery charge level is minor.

In order to qualitatively judging the presence of interactions among the three factors, an Interaction Plot is constructed in Fig. 4.8. This plot represents the means for each level of a factor with the level of a second factor held constant (considering two factors, for each combination of their levels, the mean is calculated averaging the responses obtained changing the remaining factor). Interaction between two levels is present when the response at a factor level depends upon the level(s) of other factors. Parallel lines in an interactions plot indicate no interaction. The greater the departure of the lines from the parallel state, the higher the degree of interaction [Montgomery, 2008].

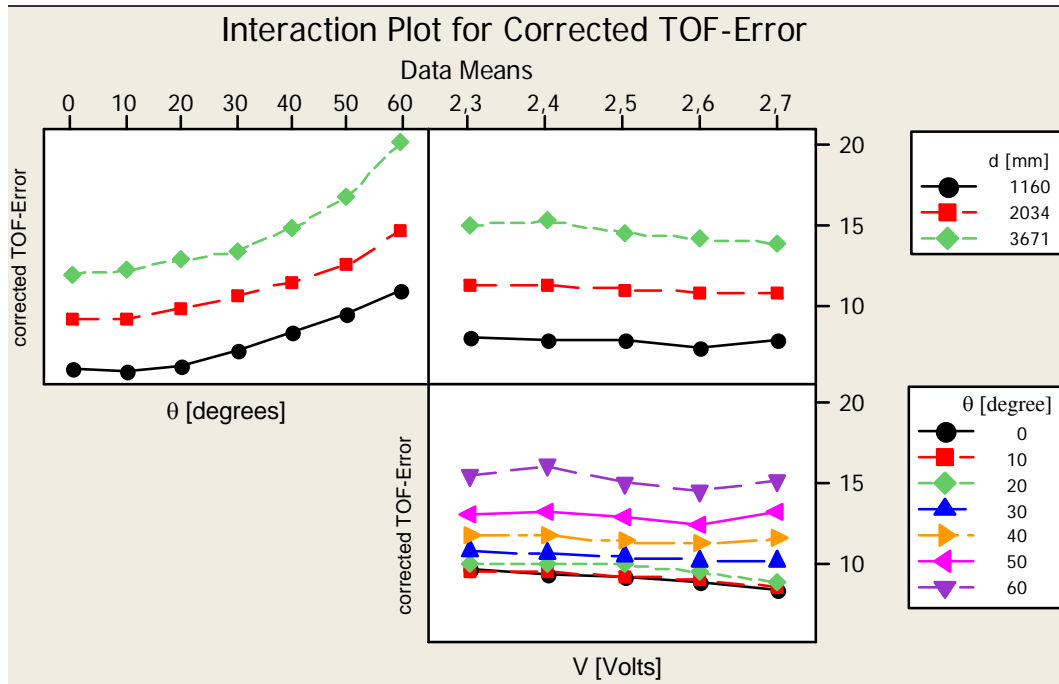

**Fig. 4.8.** Interaction plot for Corrected TOF-Error, considering the three factors ( $d$ ,  $\theta$ ,  $V$ )

The qualitative result is that misalignment angle and transmitters distance have an important effect, while the effect of battery level is minor, but not irrelevant.

Both the factors effect end their interactions are quantitatively examined by performing an Analysis of Variance (ANOVA) (see Fig. 4.9). In the ANOVA, the variance related to the response is partitioned into contributions due to the different factors and their interactions. Results of an ANOVA can be considered reliable as long as the following assumptions are met: (1) response variable is normally distributed, (2) data are independent, (3)

variances of populations are equal. After applying the Box-Cox response transformation, all these assumptions are satisfied.

Analysing the ANOVA results (Fisher's test), it can be sentenced that all three factors are significant and their interactions as well. With regard to the effect of the single factors, the most important are  $d$  and  $\theta$ , while the effect of  $V$  is minor (small  $F$  value). This is consistent with the Main Effect Plot of Fig. 4.7. With regard to the factors interactions, they are all statistically significant (small  $p$ -values), but very weak. The strongest is the one between  $d$  and  $\theta$ .

#### General Linear Model: corrected TOF error versus $d$ ; $\theta$ ; $V$

Factor	Type	Levels	Values
$d$	fixed	3	1160; 2034; 3671
$\theta$	fixed	7	0; 10; 20; 30; 40; 50; 60
$V$	fixed	5	2.3; 2.4; 2.5; 2.6; 2.7

#### Analysis of Variance for corrected TOF error

Source	DF	Seq SS	Adj SS	Adj MS	F	P
$d$	2	4071.35	4071.35	2035.67	20551.49	0.000
$\theta$	6	2368.87	2368.87	394.81	3985.88	0.000
$V$	4	44.22	44.22	11.06	111.61	0.000
$d*\theta$	12	121.55	121.55	10.13	102.26	0.000
$d*V$	8	18.09	18.09	2.26	22.83	0.000
$\theta*V$	24	30.15	30.15	1.26	12.68	0.000
Error	468	46.36	46.36	0.10		
Total	524	6700.59				

Fig. 4.9. ANOVA applied to the (transformed) response of the factorial plan

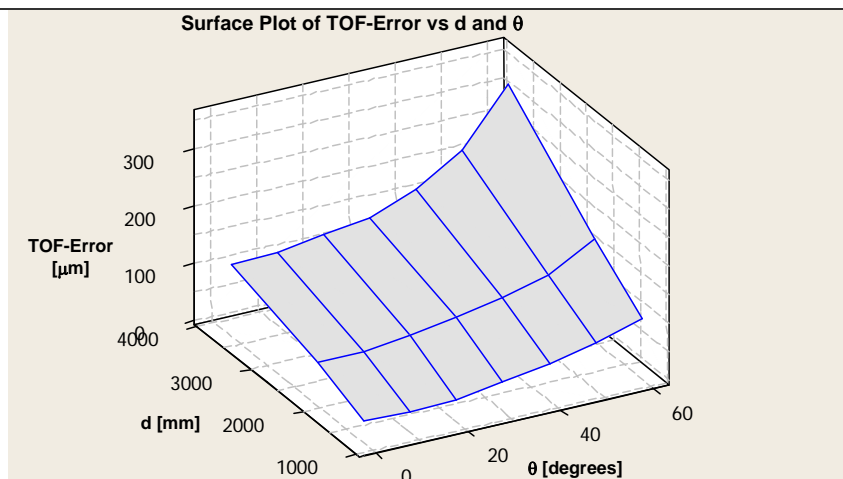
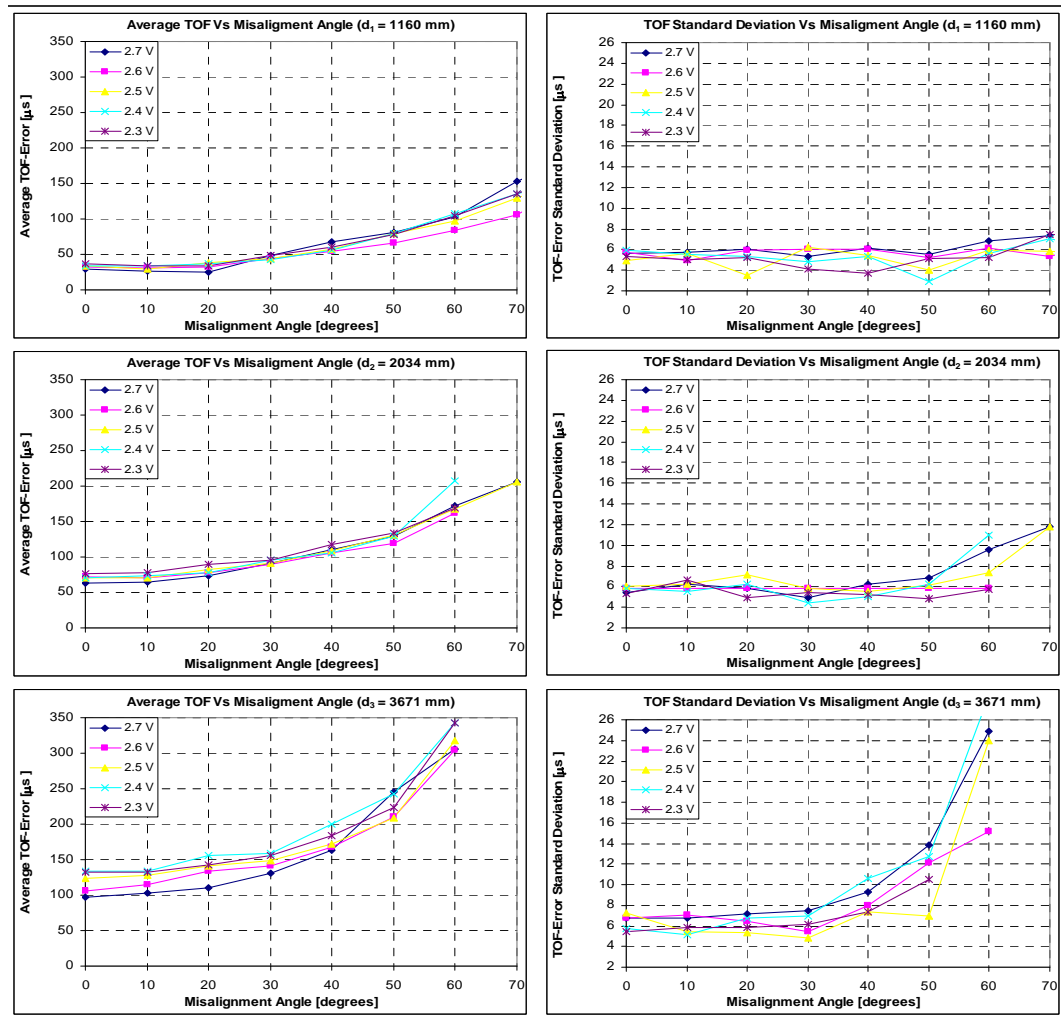

Fig. 4.10. Surface plot to represent the effect of the interaction of factors  $d$  and  $\theta$  on the TOF-Error

The effect of this interaction on the TOF-Error is represented by the surface plot in Fig. 4.10. As shown, the composition of large misalignment angles ( $\theta$ ) and large distances ( $d$ ) produces TOF-Errors which are larger than the these obtained adding the effects of the single factors, taken separately.

Another representation of the experimental outputs is given by Fig. 4.11, where the average-TOF-Error and the corresponding standard deviation (calculated for each combination of factors using the 50 repeated measurements) are plotted depending on  $V$  and  $\theta$ , for each of the 3 transceivers distances.



**Fig. 4.11.** TOF average value and standard deviation depending on the misalignment angle ( $\theta$ ) and the battery level ( $V$ ), for different transceivers distances

As already noticed, TOF-Error increases depending on  $\theta$  and  $d$ . Also, the TOF standard deviation is slightly increasing with the angle; this behaviour is more definite for large distances between transmitter and receiver.

With respect to the experimental data, in Fig. 4.11 there are some measurements not included in the factorial plan. They are TOF-Error measurements related to misalignment angles of 70 degrees, which cannot be performed for all the possible distances. For instance, considering the long transceivers distance ( $d_3=3871$  mm), transmitter and receiver are not able to communicate because of the strong signal attenuation. It can be noticed that the effect of the two most significant factors ( $\theta$  and  $d$ ) on the TOF-Error is evident, while the effect of the battery charge level ( $V$ ) is very small, compared to the previous two. TOF-Error is always positive, because of the TOF overestimation due to the signal attenuation (which is proportional to  $d$ ,  $\theta$ , and  $V$ ). The effect of the transceivers distance on the TOF-Error is also well shown in Fig. 4.12, plotting the TOF-Error versus the transceivers distance for different misalignment angles.

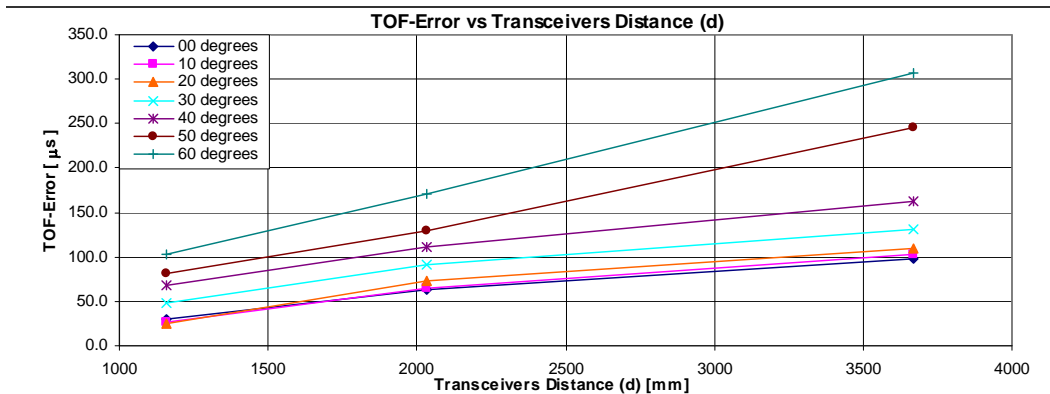

**Fig. 4.12.** TOF-Error depending on the transceivers distance ( $d$ ). The plotted curves are related to different transmitter misalignment angles ( $\theta$ ). The effect of the signal attenuation (TOF overestimation) increases with the transceivers distance

The most interesting considerations related to the factorial plan experiments are discussed and interpreted in Subsection 4.4.4.

### **Linear regression model**

Considering the results of the factorial plan, we constructed a linear regression model representing the relationship among TOF-Error and the three factors  $d$ ,  $\theta$  and  $V$ . Such a model can be useful for providing some indications on the TOF-Error expected value, de-

pending on d,  $\theta$  and V. In order to evaluate the factors interaction, but not to complicate too much the analysis, we chose a 2<sup>nd</sup> order polynomial model such as:

$$\text{TOF-Error} = C_1 + C_2 \cdot d + C_3 \cdot \theta + C_4 \cdot V + C_5 \cdot d^2 + C_6 \cdot \theta^2 + C_7 \cdot V^2 + C_8 \cdot d \cdot \theta + C_9 \cdot d \cdot V + C_{10} \cdot \theta \cdot V \quad (4.2)$$

With the support of the Minitab best regression tool, we constructed a model, which best fits experimental results (see Fig. 4.13). All the terms in Eq. 4.2 are considered to be significant, except  $C_7 \cdot V^2$  (quadratic effect of factor V) and  $C_{10} \cdot (\theta \cdot V)$  (interaction between factors  $\theta$  and V).

**Best Subsets Regression: TOF error versus d;  $\theta$ ; V;  $d^2$ ;  $\theta^2$ ;  $V^2$ ;  $d \cdot \theta$ ;  $d \cdot V$ ;  $\theta \cdot V$**

Response is TOF error

Vars No.	R-Sq	R-Sq (adj)	Mallows Cp	S	d	$\theta$	V	$d^2$	$\theta^2$	$V^2$	$d \cdot \theta$	$d \cdot V$	$\theta \cdot V$
1	80.9	80.9	2219.3	30.621							X		
1	53.5	53.4	6163.3	47.824	X								
1	51.8	51.7	6407.8	48.691				X					
2	90.1	90.0	907.8	22.117	X						X		
2	89.5	89.4	994.3	22.777				X			X		
2	89.4	89.4	1002.7	22.840	X				X				
3	92.2	92.1	607.0	19.649	X				X		X		
3	91.2	91.1	749.6	20.857				X	X		X		
3	91.0	90.9	778.3	21.093					X		X		X
4	95.7	95.6	107.1	14.632	X				X		X		X
4	95.4	95.3	149.4	15.121	X	X			X		X		
4	95.1	95.1	185.4	15.525					X		X	X	X
5	96.2	96.1	36.4	13.764	X	X			X		X	X	
5	95.9	95.9	73.8	14.224	X	X	X		X		X		
5	95.9	95.9	73.8	14.224	X	X			X	X	X		
6	96.4	96.3	10.0	13.416	X	X		X	X		X	X	
6	96.2	96.2	33.2	13.711	X	X	X		X		X	X	
6	96.2	96.2	33.2	13.712	X	X			X	X	X	X	
7	96.4	96.4	6.7	13.361	X	X	X	X	X		X	X	
7	96.4	96.4	6.7	13.361	X	X		X	X	X	X	X	
7	96.4	96.4	8.2	13.380	X	X		X	X		X	X	X
8	96.4	96.4	8.0	13.364	X	X		X	X	X	X	X	X
8	96.4	96.4	8.0	13.364	X	X	X	X	X		X	X	X
8	96.4	96.4	8.7	13.374	X	X	X	X	X	X	X	X	
9	96.4	96.4	10.0	13.377	X	X	X	X	X	X	X	X	X

**Fig. 4.13.** Results of the Minitab best regression tool

After performing the linear regression, the model obtained is:

$$\text{TOF-Error} = -61.7 + 0.113 \cdot d - 2.64 \cdot \theta - 22.8 \cdot V - 0.000005 \cdot d^2 + 0.0464 \cdot \theta^2 + 0.000791 \cdot d \cdot \theta - 0.0259 \cdot d \cdot V \quad (4.3)$$



According to the factorial plan analysis, it can be noticed that the relationship of the response (TOF-Error) with  $\theta$  can be considered to be quadratic, while the relationships with  $d$  and  $V$  can be considered to be linear. Furthermore, there are weak interactions either between  $d$  and  $\theta$  and between  $d$  and  $V$ .

---

### Regression Analysis: TOF error versus d; $\theta$ ; V; $d^2$ ; $\theta^2$ ; $d\cdot\theta$ ; $d\cdot V$

The regression equation is

$$\text{TOF Error} = -61.7 + 0.113 d - 2.64 \theta + 22.8 V - 0.000005 d^2 + 0.0464 \theta^2 + 0.000791 d\theta - 0.0259 dV$$

Predictor	Coef	SE Coef	T	P
Const	-61.71	25.42	-2.43	0.016
D	0.11333	0.01086	10.44	0.000
$\theta$	-2.6429	0.1231	-21.46	0.000
V	22.819	9.959	2.29	0.022
$d^2$	-0.00000469	0.00000088	-5.34	0.000
$\theta^2$	0.046412	0.001683	27.57	0.000
$d\cdot\theta$	0.00079060	0.00002801	28.22	0.000
$d\cdot V$	-0.025872	0.003962	-6.53	0.000

S = 13.3608 R-Sq = 96.4% R-Sq(adj) = 96.4%

#### Analysis of Variance

Source	DF	SS	MS	F	P
Regression	7	2479914	354273	1984.60	0.000
Residual Error	517	92290	179		
Total	524	2572205			

Source	DF	Seq SS
D	1	1376051
$\theta$	1	799368
V	1	13900
$d^2$	1	5096
$\theta^2$	1	135709
$d\cdot\theta$	1	142179
$d\cdot V$	1	7613

---

Fig. 4.14. ANOVA applied to the regression output

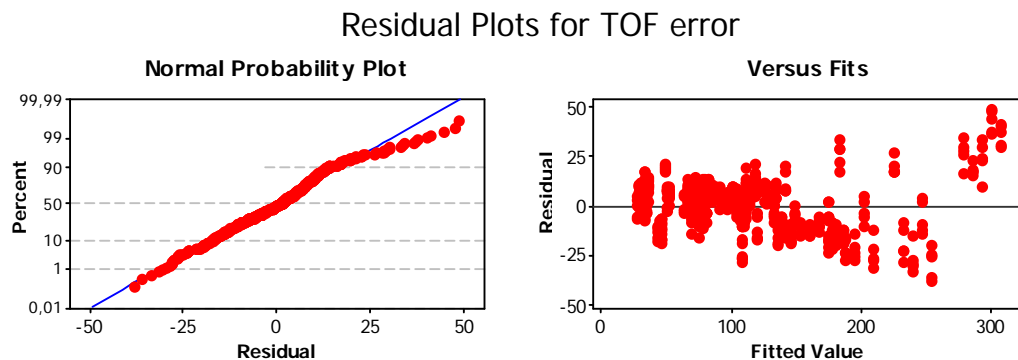

Fig. 4.15. Residual plots related to the regression model response

The regression output is quantitatively examined by an ANOVA (see the table on Fig. 4.14). Analysing the results, it can be sentenced that all the terms in Eq. 4.2 are significant. Examining the residual plot (Fig. 4.15), we can notice that residuals behaviour seems to be random, even if the dispersion is not constant. This is consistent with the fact that the TOF-Error distribution is not homoscedastic.

#### 4.4.2 Interpretation of the results

Summarising, we can say that TOF-Errors can be influenced by three factors related to the US signal attenuation. In particular, we have found that:

- the most important factors interaction is between  $d$  and  $\theta$ . transducer distance ( $d$ ) and misalignment angle ( $\theta$ ) have great effect;
- transceivers battery charge level ( $V$ ) has a small effect;
- the most important interaction is due to factors  $d$  and  $\theta$ .

The experimental confirmation that these three factors are sources of US signal attenuation is given by the TOF overestimation. Each item generates a reduction in the US signal amplitude, due to the implementation of the thresholding signal detection method.

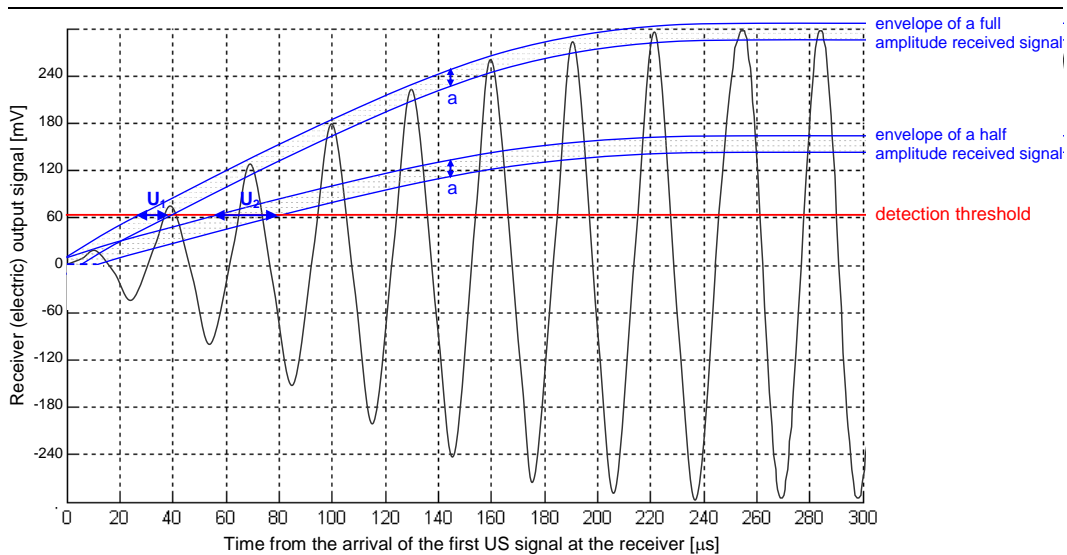

**Fig. 4.19.** Considering the same variability ( $\Delta V$ ) in the receiver voltage signal, the corresponding uncertainty in the time-of-flight changes. The more attenuated the signal, the larger the time-of-flight variability

Another interesting result is that the standard deviation related to TOF-Error is dependent on the US signal attenuation. This behaviour is a consequence of the thresholding de-

tection method. Since each transmitter is characterized by a proper natural variability (due to power and control supply, air conditions, and so on), the envelope of the US signal at the receiver will be included within an uncertainty bandwidth (in grey in Fig. 4.19). Considering signals with different amplitudes and assuming the uncertainty bandwidth to be the same, the larger the transient slope, the lower the TOF uncertainty (“U1” and “U2” in Fig. 4.19).

Obviously, this behaviour is directly caused by the use of the thresholding detection method and it is a source of inaccuracy in TOF estimation. Cricket’s accuracy could be improved if the receiver could exactly calculate when it received the start of the pulse, by implementing a more refined US detection method.

#### 4.4.3 Additional experiments

The two following paragraphs present two additional experiments, aimed at deepening the analysis carried out by the factorial plan. They respectively are:

1. complete battery discharge cycle to investigate in detail the relationship between the battery level and the error in the TOF evaluation;
2. analysis of the repeatability of Cricket devices in the TOF measurements.

##### ***Analysis of the Cricket devices battery discharge***

Factorial plan results showed that the battery level has a small effect on TOF-Error.

However, abnormal TOF-Error measurements were noticed during the last part of the Cricket devices battery life. This test aims at studying the relationship between the battery charge level and the error in the TOF evaluation. It consists in measuring TOF-Error at more than a hundred different transmitter battery levels, from a full charge to a complete battery discharge. Transmitter and receiver are positioned at the known distance of 1582 mm, with their faces perfectly aligned ( $\theta = 0^\circ$ ).

Here are presented the results of the analysis of TOF-Error and the respective standard deviation for different battery levels, during a complete battery discharge cycle. Two characteristic phases can be identified in the curve plotted on Fig. 4.16:

**Ph. 1.** The battery charge level decreases very slowly with the battery life time. The average TOF-Error and the TOF-Error standard deviation are not significantly influenced by the battery level.

**Ph. 2.** In the final part of the battery life (potential difference lower than 2.3 V), the discharge is very quick and the measured potential difference falls to zero rapidly. This phase is characterised by a “knee” in the battery charge level curve. In this phase, the corresponding TOF-Error average value and standard deviation “explode”.

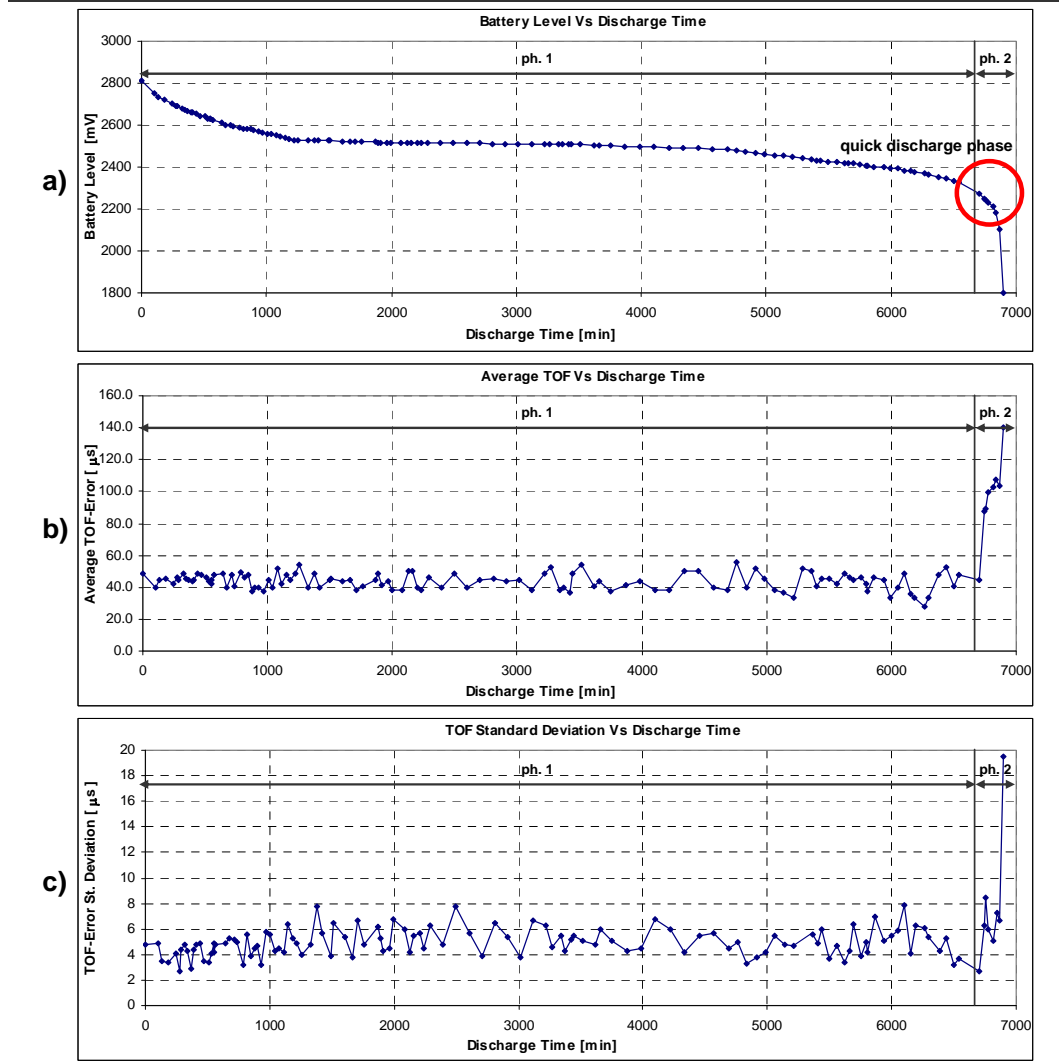

**Fig. 4.16.** Battery level (a), average TOF-Error (b) and TOF-Error standard deviation (c) depending on the Cricket devices battery discharge time. Each point value is calculated over 100 individual measurements

As a result, in order to avoid a wrong estimate of TOF, it is important to replace the batteries before they reach the “quick discharge phase”. This purpose can be automatically succeeded by controlling the Crickets battery level through a firmware utility [Shnayder et al., 2004].

**Test of repeatability of the US transducers**

The US transceivers repeatability is tested positioning three different couples of Cricket transceivers at the same known distance (3633 mm) with their faces perfectly aligned. For each couple of devices, 100 different individual TOF-Error measurements are taken.

Data are analysed by a one-factor Analysis of Variance (ANOVA), to test the null hypothesis that there is no difference in the TOF-Errors mean values measured by different couples of transceivers (the examined factor).

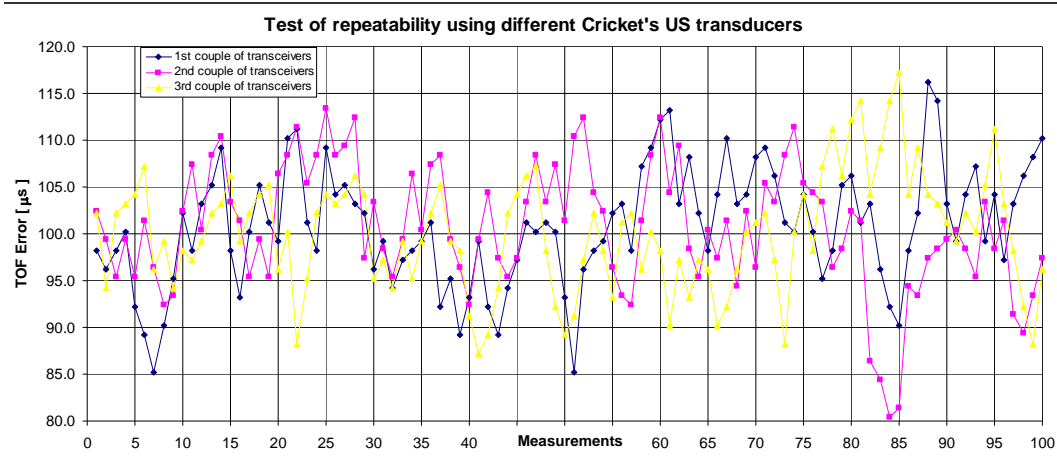
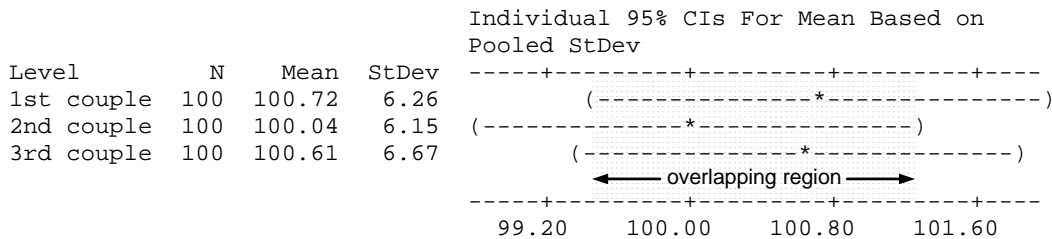

**Fig. 4.17.** Plot of TOF-Error from different Cricket’s US transducers

As expected, TOF-Error does not significantly change depending on the different Cricket devices used. Fig. 4.17 shows the plot of the TOF-Error measured 100 times in the same conditions, using 3 different couples of Cricket transceivers.

**One-way ANOVA: 1st couple, 2nd couple, 3rd couple of Cricket transceivers**

Source	DF	SS	MS	F	P
Factor	2	26.6	13.3	0.33	0.720
Error	297	12019.9	40.5		
Total	299	12046.6			



Pooled StDev = 6.36

**Fig. 4.18.** Results of an ANOVA to test the Cricket’s US transducers repeatability

As shown, measurements obtained using different devices generally overlap. Consequently, it can be said that the use of different US transducers devices does not influence the TOF-Error. This qualitative impression is confirmed by the results of the ANOVA in Fig. 4.18.

#### 4.5 Final notes and future work

The chapter analysed the most important sources of error, related to the TOF measurements performed by the US transducers, which MScMS is equipped with. Measurement error may change depending on many different factors; however, the most important effects are due to the US signal attenuation, which may have three major sources: (1) transceivers distance, (2) transceivers misalignment angle, (3) transducer battery charge level. In particular, the paper shows that transducers misalignment and transceivers distance are the most significant. This statement is supported by the results of an organic experimental factorial plan. It is important to remark that this source of error is directly caused by the method of thresholding US detection method. Typically, attenuation may produce an overestimation of several centimetres (up to 3÷4 cm!) in distance evaluation. Also, these results can be useful to identify the major MScMS sources of inaccuracy and to determine how the error in TOF evaluation changes in the different points within the Cricket transmitters' "cones of vision". An organic analysis of the combined effect of the transmitter and receiver orientations on TOF-error will be the object of a future work.

Regarding the future, Cricket's accuracy could be improved using more refined ranging methods (for example, based on phase-detection with fixed-frequency signals and with frequency-modulated signals). Unfortunately, these detection methods are more expensive. Another possible solution to the error derived by the transmitter misalignment is the use of omnidirectional ultrasonic transducer, like the cylindrical polyvinylidene fluoride (PVDF) film transducers [Toda, 2002]. The TOF measurement error can be also reduced by implementing proper compensation techniques.



## 5. MScMS and CMMs: a structured comparison

### 5.1 Introduction

The goal of this chapter is comparing MScMS with well-tested and widespread instruments such as classical Coordinate Measuring Machines (CMMs). MScMS and CMMs have many common aspects. For both the systems, measurements are taken touching few points on the objects surface with a probe tip; points are defined on a Cartesian coordinate system and then coordinates are processed by specific algorithms in order to determine geometrical features, angles, other objects shapes etc. On the other hand, MScMS and CMMs have many different characteristics, such as their physical structure, size, cost, etc. This comparison will be carried out according to a structured set of evaluation criteria.

The chapter is organised in five sections. Section 5.2 refers to CMMs main characteristics. Section 5.3 illustrates the comparison criteria with which MScMS and classical CMMs will be compared. Section 5.4 shows the results of this comparison. Finally, the most important results are summarized.

### 5.2 CMMs main characteristics

The CMMs are complex mechanical devices to determine the coordinates of the points touched by an electromechanical probe. CMMs can be controlled either manually or by Computer Numerical Control (CNC) systems; they are available in a wide range of sizes and designs, offering a variety of different probe technologies. CMMs consist of three basic components (see Fig. 5.1):

- the *machine body*: three carriages move the probe along the X, Y and Z Cartesian coordinate axes;
- a *measuring probe*: to touch the surface points of a workpiece;
- a *control and computing system*: to calculate the Cartesian coordinates of the points and evaluate the shape/features of the workpiece's surface.



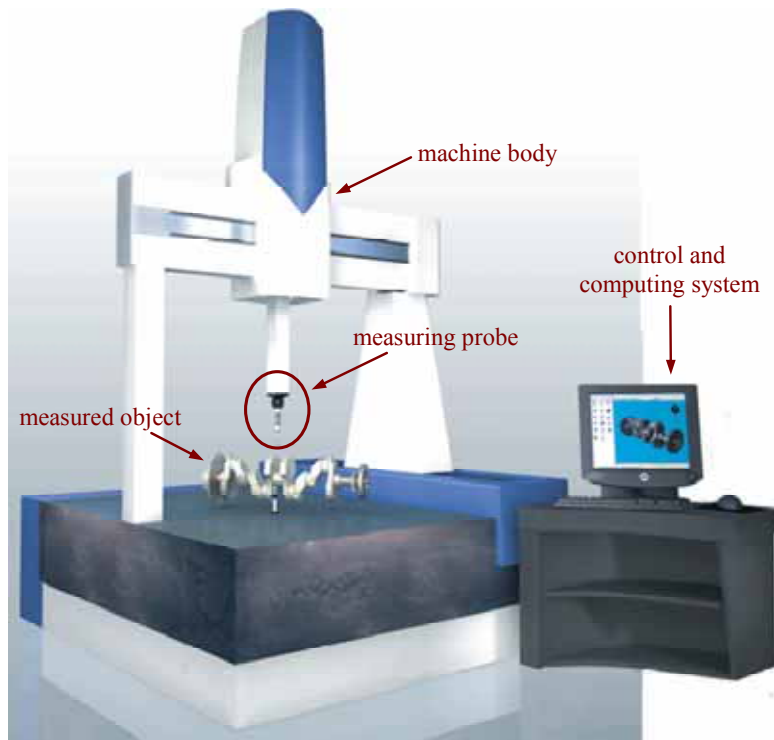

**Fig. 5.1.** A typical Coordinate Measuring Machine (CMM) [DEA, 2007]

CMMs are widely used in many industrial sectors to perform product control. The reason why they are so widespread is their reliability and accuracy [Curtis and Farago, 1994]. CMMs software makes it possible to perform complex types of measurement (surface construction, intersections, projections). In spite of their diffusion, these machines can not measure every kind of object. With a few exceptions (*gantry* or *horizontal arm* CMMs, which are expensive and not portable), CMMs can not measure large-size objects, due to their limited measuring volume.

### 5.3 Comparison criteria

The MScMS prototype has been designed to be portable, with the aim of measuring large-size objects and minimizing manual activities. MScMS and CMMs will be compared according to the set of criteria/requirements listed in Tab. 5.1.

In the following subsections, the previous criteria are individually analysed in order to perform specific comparisons between MScMS and classical CMMs.

**Tab. 5.1.** Comparison criteria

5.3.1 Portability	
5.3.2 Working volume	Size Geometry
5.3.3 Set up	Installation Start up Calibration, verification and system positioning
5.3.4 Metrological performances	Dimensional measurement Other kinds of measurements
5.3.5 Measurements system diagnostics	On line Off line
5.3.6 Ease of use	Automation Software user interface
5.3.7 Flexibility	Kind of measurement Geometric relation Concurrent measurements
5.3.8 Cost	Purchasing Maintenance
5.3.9 System management	Set up phase Measuring phase

### 5.3.1 Portability

MScMS is composed by distributed and lightweight wireless devices, which are easily portable and installable in the area around the measured object. They can be fixed to the ceiling or mounted on standard supports and tripods (see Fig. 3.1).

While the MScMS components can be moved to different operating environments, traditional CMMs are embedded in a precise working area. Once installed, CMMs have to be permanently used there. To be moved, they need to be disassembled, re-assembled, re-installed and re-started up, spending a lot of time and with much effort.

### 5.3.2 Working volume

#### *Working volume size*

The big difference from traditional CMMs is that MScMS structure is not rigidly connected. It is made of separate components (wireless constellation devices) that should be easily moved and arranged around the measuring area depending on the exigency. MScMS is *scalable* (or modular), since the number of constellation devices can be increased depending on the measurement volume to be covered, without compromising network communication and slowing down measurement activities.

On the contrary CMMs are rigid and bulky systems in which the dimensions range can reach tens of meters. There is a great variety of CMMs, their working volume size can go up to hundreds of cubic meters. As discussed in the following sections, performances and costs are strongly influenced by CMMs dimensions [Phillips et al., 2000].

### **Working volume geometry**

MScMS may work in a non convex working volume, that is to say, a volume which does not contain the entire line segment joining any pair of its points (e.g. points A and B in Fig. 5.2). MScMS, due to its distributed nature, easily fit different types of indoor working environments, even with inside obstacles.

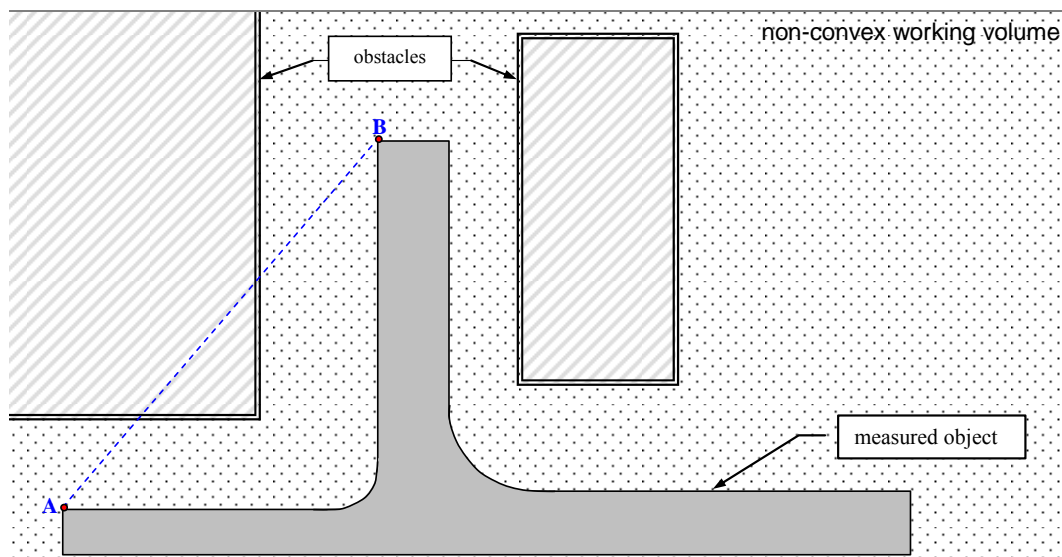

**Fig. 5.2.** Representation scheme of the concept of non-convex working volume (plant view)

Considering CMMs, there are not discontinuities in the measuring volume, since all the points within this area can be reached by the electromechanical probe.

Although there are CMMs with large working volumes (i.e. *horizontal-arm* and *gantry* CMMs), the presence of obstacles in the proximity of the measured object can be problematic, since they may collide with the moving carriages. Considering this aspect, MScMS is more flexible than CMMs.

### 5.3.3 Set up

#### ***Installation***

MScMS gives the opportunity of arranging constellation devices in different ways, depending on the application requirements. Every time the system is installed a localization should be performed. This step needs to be completed before performing measurements and has strong effects on the measurements accuracy. MScMS software provides a semi-automatic procedure to achieve the constellation localization, minimizing the user's effort (see Subsection 2.4.4) [Patwari et al., 2005; Franceschini et al., 2008-I]. It makes it possible to calculate the position of the wireless devices arranged around the measuring area and to establish a Cartesian coordinate reference system [Nagpal et al., 2003].

CMMs installation requires a great effort: the system - made of different components - has to be carried and assembled into the working place by highly skilled technicians.

#### ***Start up***

MScMS should be started-up in order to activate the communication between the PC and the system, and for selecting the mobile probe type. Probe qualification makes it possible to know the probe geometrical characteristics, necessary to determine the coordinates of the points touched by the probe's tip [Franceschini et al., 2008-II].

Also CMMs should be started-up for activating the communication between the PC and the control system, and for selecting the mobile probe type.

#### ***Calibration, verification and system positioning***

- *Calibration.* It is defined as: "operation establishing the relation between quantity values provided by measurement standards and the corresponding indications of a measuring system, carried out under specified conditions and including evaluation of measurement uncertainty" [ISO, 1993]. In general, calibration defines a rule which converts the values output by the instrument's sensors to values that can be related to the appropriate standard units. Importantly, these calibrated values should be associated to corresponding uncertainties, which reliably take into account the uncertainties of all the quantities that have an influence.

For MScMS, calibration is an operation that can be performed every time the system is started up. This in order to test system integrity and to set those parameters on which measurements depend (temperature, humidity etc.). This operation does not need a so-

phisticated instrumentation and it is carried out by measuring a standard reference artefact, with *a priori* known geometry.

Obviously, this calibration procedure is not valid for CMMs because of their different technology and, in particular, their rigid structure. CMMs calibration can not be accomplished directly by the user, but requires a more complex procedure defined by international standards [ISO 10360, 2001]. In particular, CMMs calibration consists in a sequence of manual activities that must be carried out once or twice a year, and requires highly qualified operators and complex instruments like laser interferometers.

- *Verification*. It is defined as: “confirmation through examination of a given item and provision of objective evidence that it fulfils specified requirements” [ISO, 1993]. Another activity to make MScMS suitable for the measurement is the system verification. It should be periodically performed to verify and adjust the measuring scale adopted (for example, the ultrasound speed changes with air temperature and humidity). This operation is performed by the use of a standard reference artefact [ISO 10360, 2001]. CMMs verification is done using some standard reference artefacts or repeatedly measuring the same points to evaluate eventual measurements drifts. Different approaches have been proposed in this direction [Franceschini and Galetto, 2007]. Whenever a CMM does not fulfil specified requirements, highly qualified operators have to intervene.
- *System positioning*. It is defined as: “operation establishing the initial position of the constellation devices”. Every time MScMS is installed, a crucial activity is the constellation devices positioning. In order to locate the mobile probe, MScMS has to know the position of constellation devices. This step needs to be completed before performing measurements and has strong effects on the measurements uncertainty. MScMS software provides a semi-automatic procedure to achieve the constellation localization, minimizing the user’s effort. CMMs do not need such procedure, due to the different system technology.

### 5.3.4 Metrological performances

#### *Dimensional measurement*

The technology employed (in particular, the use of US transceiver) is responsible for MScMS’s low accuracy compared to CMMs [Franceschini et al., 2008-II]. The use of US

transducers can be critical for measurement accuracy, because of many aspects, already discussed in Section 4.3.

In order to give an idea of MScMS prototype performances, repeatability and reproducibility tests have been carried out. Results are reported in Tab. 3.1.

Also CMMs performances may change depending on many factors like machine dimensions, climatic conditions or probe speed of contact. Nevertheless CMMs are some order of magnitude more accurate than MScMS. To provide an example of CMMs standard performance, Tab. 5.2 reports the maximum permitted error (MPE) on distance measurements related to a standard CMM machine [DEA, 2007]. In general, the MPE grows up with the dimension of the CMM.

**Tab. 5.2.** Performance of a standard CMM [DEA, 2007]

Standard CMM performance			
Stroke x (mm)	Stroke y (mm)	Stroke z (mm)	MPE-E for ISO 10360/2 ( $\mu\text{m}$ )
500	700	500	from $1,5 + L/333$

#### ***Other kinds of measurements***

While CMMs have been designed with the purpose of performing only dimensional measurement, MScMS can carry out other kinds of measurement. More precisely, Cricket devices may be equipped with additional sensor boards. This gives the possibility to MScMS associate single position measurements with other kinds of measurement, such as light intensity, temperature, acceleration, magnetic field, pressure, humidity or noise pollution. Accuracy of these kinds of measurement depends on embedded sensors utilized [Crossbow Technology, 2008].

### **5.3.5 Measurements system diagnostics**

#### ***On-line measurements diagnostics***

As said before, MScMS is sensible to external factors, such as environmental conditions (temperature, humidity, presence of obstacles among distributed devices). MScMS software provides some diagnostic tools to control the measurements activities and assist in the detection of abnormal functioning. Firstly, it gives the opportunity of watching the data exchanged among the wireless devices, making it possible to discover abnormal functioning of the system components. Secondly, it allows a graphic display of the probe's range of vision, that is to say the set of constellation devices it can communicate

with (see Fig. 5.3). This helps the operator to check whether the probe is in the optimal position to perform a specific measurement (i.e. if it communicates with at least 4 constellation devices). Furthermore, we implemented a diagnostic tool with the purpose of filtering “wrong” distances among Cricket devices: US reflection, diffraction, or other measuring accidents [Moore et al., 2004].

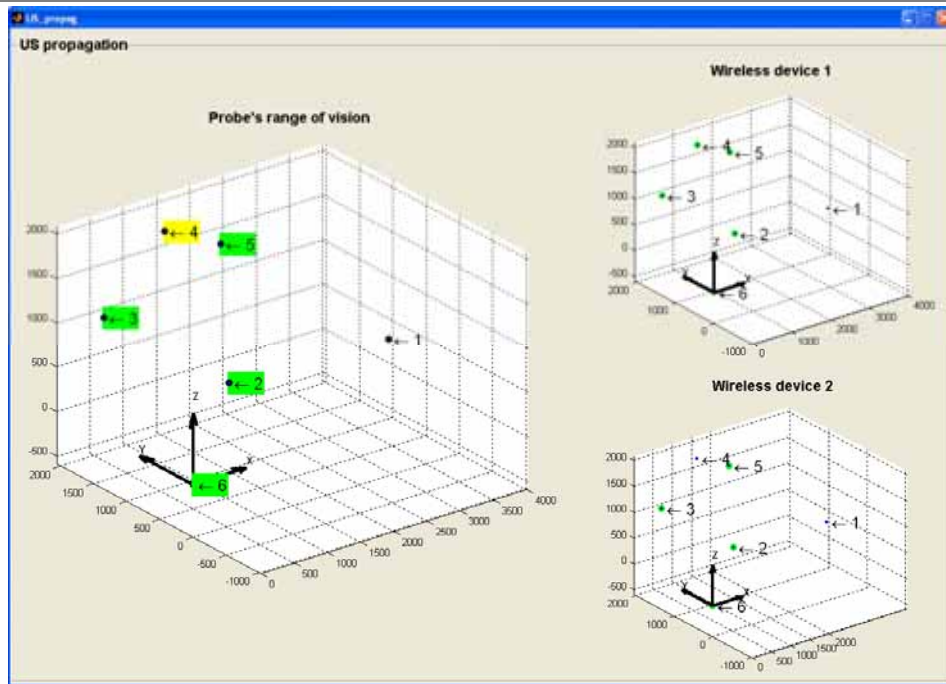

**Fig. 5.3.** Graphic representation of the probe range of vision. The right part of this screenshot shows the constellation devices seen by the mobile probe Crickets

On the other hand, CMMs do not offer on-line diagnostics for single point measurements but only for shape measurements: if the reconstructed shape does not reasonably fit the measured points, then a warning signal is reported. This kind of diagnostics is only possible when there is a significant measurements redundancy (for example five or more points to construct a sphere or four or more to construct a circumference). Similar diagnostic tools can be implemented for MScMS.

#### ***Off-line measurements diagnostics***

Both CMMs and MScMS can provide very similar off-line diagnostic tools. These diagnostics are based on the concept of measurement replication: if variability is higher than expected, measurements are considered not reliable [Franceschini et al., 2007-II]. During a measurement cycle some known points are repeatedly touched by the probe at regular

intervals. If the variability of these points measurements is larger than expected, the measurement cycle stops, because this is the symptom that CMMs performance is deteriorating. As a consequence whenever a stop occurs, the operator has to investigate about its reason. Although being performed during the measurement cycle, these diagnostics can not be considered as on-line, since they are performed after measurements.

### **5.3.6 Ease of use**

#### ***Automation***

MScMS and traditional CMMs are equipped with software packages which automate data processing. Due to its technology, MScMS operates only manually: the user brings the mobile probe to the object in order to touch a set of points on its surface. This is an important difference from CMMs, which are typically controlled by CNC. CMMs software makes it possible to create routines to automatically perform the same measurements on identical objects. This implies a large reduction of time and costs when the number of (identical) objects to be measured is large. By means of a self learning tool, the user can also choose to manually measure the first object allowing the system to learn the measurement patch to be repeated.

Unfortunately, the MScMS software does not provide the same facility, due to the manual nature of measurements.

#### ***Software user interface***

Both devices (CMMs and MScMS) provide a software user-interface. Their functions are based on a similar structure, with the aim of guiding the user through the various activities.

Tab. 5.3 summarizes the results of a comparison between the MScMS and CMMs software user interfaces.

As for CMMs, MScMS software has been developed to help operators by:

- leading them through the start-up and measuring activities;
- providing tools and functions which simplify their work;
- displaying the results in a clear and complete way.



**Tab. 5.3.** Comparison between the MScMS and CMMs software packages

Stage	Activities	Software tools	
		MScMS	CMMs
System startup	System initialization	<ul style="list-style-type: none"> <li>Semi-automatic procedure to open the Bluetooth connection</li> </ul>	<ul style="list-style-type: none"> <li>Semi-automatic procedure to start up the measuring machine</li> </ul>
System presetting	Probe qualification	<ul style="list-style-type: none"> <li>(Manual) definition of the probe's geometrical features</li> </ul>	<ul style="list-style-type: none"> <li>Semi-automatic procedure for the probe qualification</li> </ul>
	Constellation localization	<ul style="list-style-type: none"> <li>Semi-automatic procedure, guided by visual instructions</li> <li>Display and memorization of the localized constellation layout</li> </ul>	-
Dimensional measurement	Choice of the measuring activity	<ul style="list-style-type: none"> <li>Single shape measurement.</li> <li>Relationships among different shapes (distances, intersections or angles)</li> </ul>	idem
	Selection of the shape (or relationship) to measure	<ul style="list-style-type: none"> <li>Selection of the shape (or relationship) to measure</li> </ul>	idem
	Measurement execution	<ul style="list-style-type: none"> <li>Measurement setting and execution</li> </ul>	idem
	Audio-visual signals	<ul style="list-style-type: none"> <li>Warning signals</li> <li>Display of the probe's communication range and network connectivity</li> </ul>	<ul style="list-style-type: none"> <li>Warning signals</li> </ul>
	Output display	<ul style="list-style-type: none"> <li>Numerical and graphical display of the measured points</li> <li>2D and 3D charts</li> <li>Numerical and graphical display of the object's features</li> <li>Measurements System diagnostics</li> </ul>	idem

The software structure is modular (see the representation scheme in Fig. 5.4). Each module is associated to a specific activity (system start-up, dimensional measurements, results displaying). Modules are linked together by different operational paths.

Each path represents a sequence of screenshots. The great advantage of a modular structure is that it can be progressively extended according to the measuring system enhancement.

Fig. 5.5 to 5.7 show some screenshots of MScMS user interface.

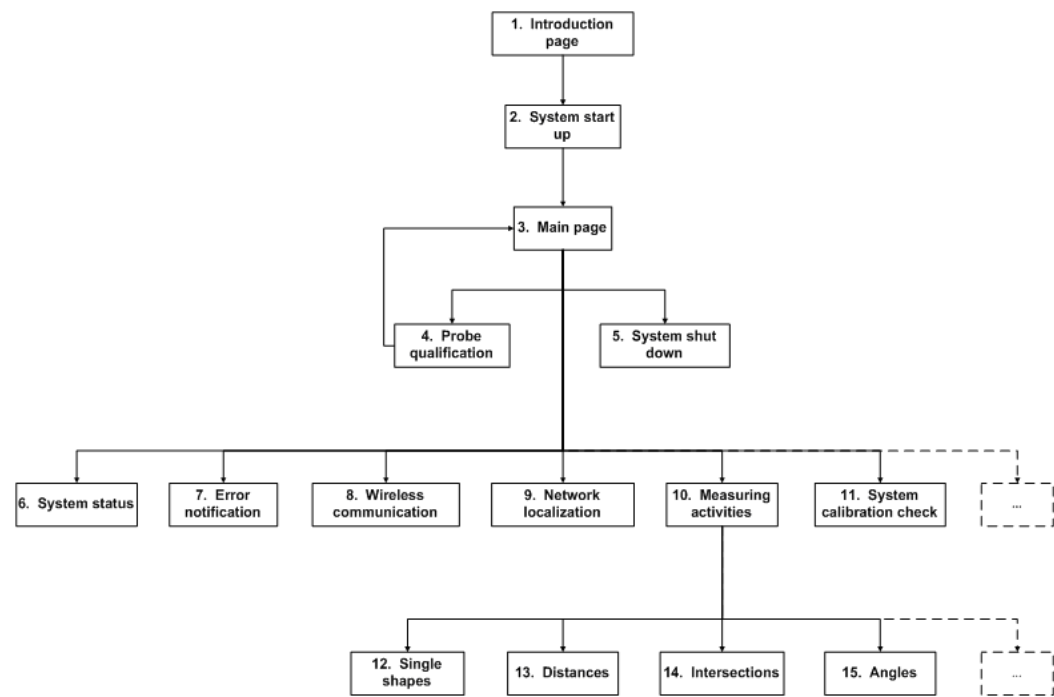

Fig. 5.4. MScMS software architecture



Fig. 5.5. The MScMS's main menu screenshot

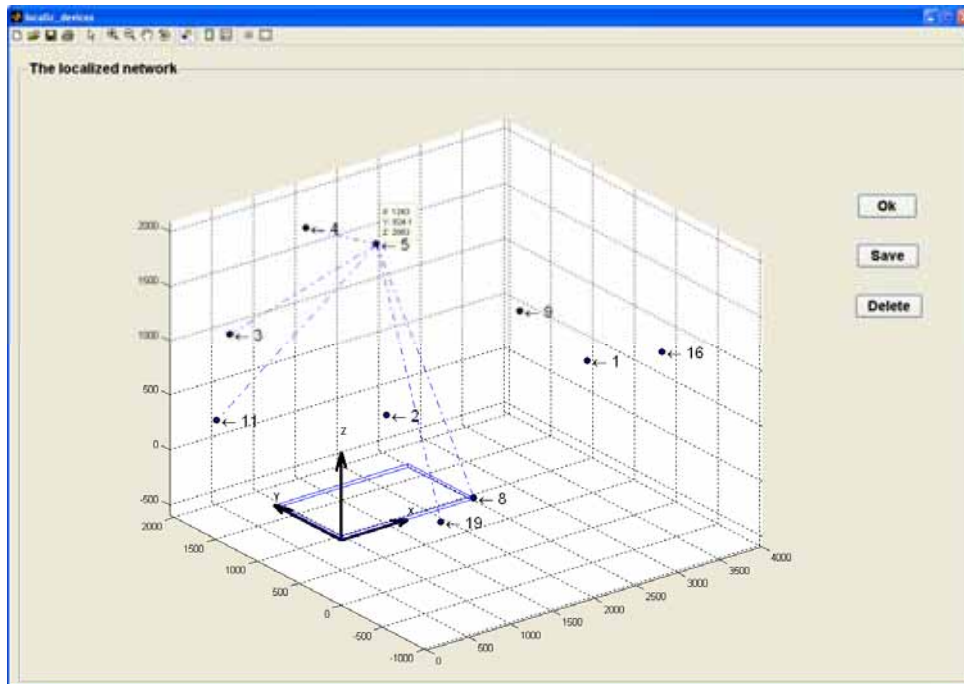

Fig. 5.6. The localized wireless constellation devices

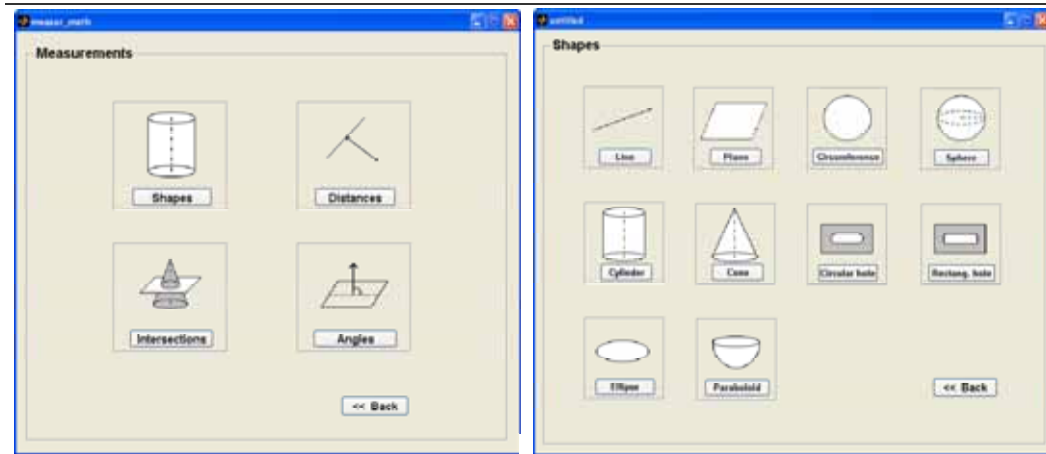

Fig. 5.7. (a) Choice of the measuring activities

(b) Single shape measurement

### 5.3.7 Flexibility

#### *Kinds of measurement*

Considering flexibility as the ability of performing different types of measurement, MScMS is more flexible than classical CMMs. As described above, MScMS offers the possibility of simultaneously performing different measurements (light, acoustic noise,

pressure, temperature, acceleration, magnetic field and humidity), associating them to the position measurement. These kinds of measurement, which can not be achieved with a classical CMM, can be useful for the mapping of indoor environments [Fischer et al., 2001; Lilienthal and Duckett, 2004; Safigianni et al., 2005].

### **Geometric relations**

The software functions offered by MScMS are very similar to those offered by classical CMMs:

- *single shape measurement* (block 12 in Fig. 5.4). In this case the measured workpiece's feature corresponds to a precise geometric shape (circle, plan, cylinder, etc...);
- *relationships among different shapes*. The measured feature arises from a relationship between two or more different parts of the object's shape, like distances, intersections or angles between curves/surfaces (blocks 13÷15 in Fig. 5.4).

### **Concurrent measurements**

A significant peculiarity of MScMS is given by the flexibility of the Cricket devices. They are light, small and cheap and have an embedded processor to perform easy computations. For this distributed computational capacity, MScMS can simultaneously support two or more probes, in order to execute concurrent measurements. It is so possible to perform simultaneous measurements on a single object or even on different objects, improving the system sample rate. As the MScMS constellation is scalable and can assume different topologies, different operators can measure different objects in different parts of the network.

CMMs are not able to simultaneously perform more than one measurement at a time.

## **5.3.8 Cost**

### **Purchasing**

Cost is a point in favour of MScMS. Its components (Cricket devices, supports and booms, adapters...) have an individual cost of the order of some tens of euros. As a consequence, the system overall cost is in the order of some thousands of euros. On the other hand, the cost of classical CMMs – even the most economical and simple – is one or two order-of-magnitude higher.

**Maintenance**

The MScMS system does not need a really complicate maintenance. Maintenance costs are low since the system does not require the intervention of highly qualified operators. Activities of calibration and verification can be easily carried out by the user.

CMM maintenance is a much more complicated activity, because it needs well prepared operators to maintain the system. Typically maintenance contracts cost about three thousand euros per year, for a single CMM.

**5.3.9 System management**

From a system management point of view, the two measuring systems mayor implications concern two phases: set-up and measuring.

**Set up**

Before performing measurements, both the 2 systems need to be set-up. Regarding MScMS, the operator has the possibility of placing the constellation devices freely around the workpiece. He should take care of using a proper number of constellation devices, and setting their orientation in order to cover the measuring area. After this, a semi-automatic localization procedure can be performed to locate the constellation devices. This procedure consists in measuring an artefact with known geometry, in different positions within the working volume. On the other hand, the set-up procedure for CMMs is much more complex and requires highly skilled technicians and complex instruments (like interferometric laser tracers).

**Measuring**

For both the two systems, the measuring phase is rather user-friendly. Regarding MScMS, the system makes it possible to modify the measuring volume depending on the exigency (e.g. when the workpiece is moved or replaced with a different one), simply adding or moving some of the constellation devices. Of course, every time the position of one or more constellation devices is changed, the set-up phase should be performed again. On the contrary, CMMs are rigid systems in which the working volume size is fixed.

## 5.4 Final considerations

This chapter compared MScMS to CMMs, the most commonly used devices for objects dimensional measurements.

MScMS and classical CMMs are similar considering measurement activities; however – due to their different technological features – they have many differences (for example system presetting, start-up, measurement execution, etc...). In our opinion, they can easily coexist, since each system has some peculiar technological features that make it suitable for specific uses. The lower accuracy of MScMS makes it difficult to compete with CMMs for measuring small-size objects. However, MScMS becomes competitive in the dimensional evaluation of large-size workpieces, where is often required to move the machine to the place where the object is. Furthermore, MScMS offers the possibility of simultaneously performing different measurements (light, acoustic noise, pressure, temperature, acceleration, magnetic field and humidity, gas concentration), associating them to the position measurement [Fischer et al., 2001; Lilienthal and Duckett, 2004; Safi-gianni et al., 2005]. These kinds of measurement, which can not be achieved with a classical CMM, can be useful for the mapping of indoor environments.



## 6. iGPS performance evaluation and comparison with MScMS

### 6.1 Introduction

This chapter describes the indoor-GPS (iGPS), an innovative measuring system to perform dimensional measurements on large-scale object. The system, based on laser technology, has many common aspects with MScMS. The two systems are portable and easy to install and have components with small dimensions that are distributed around the measuring area. For both the systems, measurements are taken touching few points on the objects surface with a probe tip. Points are defined on a Cartesian coordinate system and then coordinates are processed by specific algorithms, in order to determine the surface geometrical features (angles, distances, other objects shapes etc..).

The remainder of this chapter is organised into six sections. Sections 6.2 and 6.3 provides an introduction to the iGPS technological features and *modus operandi*. Section 6.4 analyses in detail the most important factors affecting measurements. Section 6.5 reports on the system performance and the most important factors affecting it as evaluated by a number of initial tests, carried out in collaboration with the University of Bath. For the experimental work described in this section, an iGPS system equipped with 4 transmitters was used. Section 6.6 compares the iGPS with MScMS, emphasising their many common aspects and their differences. The comparison is carried out according to a structured set of evaluation criteria. Finally, Section 6.7 gives the conclusions and future directions of this research.

### 6.2 iGPS structure

Before describing the iGPS characteristics, here we present a classification of large-scale metrology measurement systems (see Fig. 6.1). These systems can be divided into *centralized* and *distributed*. In the case of centralized systems, measurements can be obtained by a single stand-alone unit, which is a complete system (like a Laser Tracker). While the distributed instruments are made of two or more distributed units, for example the



MScMS system uses a network of devices. In general, distributed measurement systems, due to their topology and the light weight of each of their units, are portable and can be easily transferred to the measurand.

The other distributed contact measuring instruments shown in Fig. 6.1 are the Metris iGPS and the 3<sup>rd</sup> Tech Hi-Ball. Hi-Ball is a system composed of a number of infrared LEDs, arranged around the measuring area, which can be viewed by an optical sensor probe measuring the object surface. The probe is able to locate itself measuring the angles from the LEDs and performing a triangulation [Welch et al., 2001].

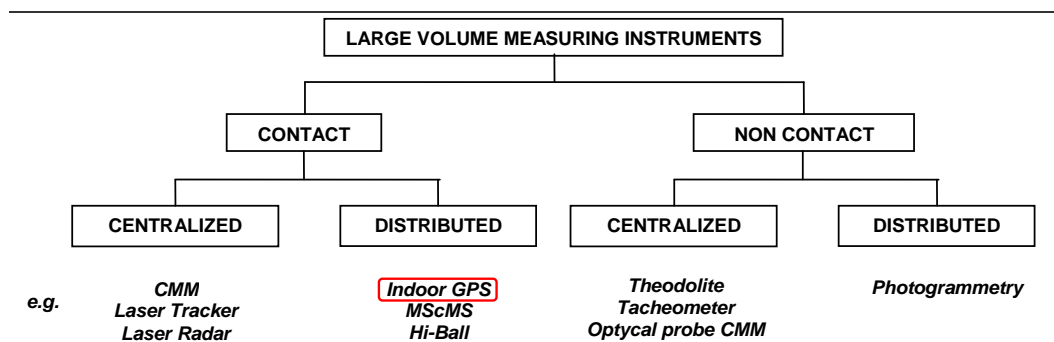
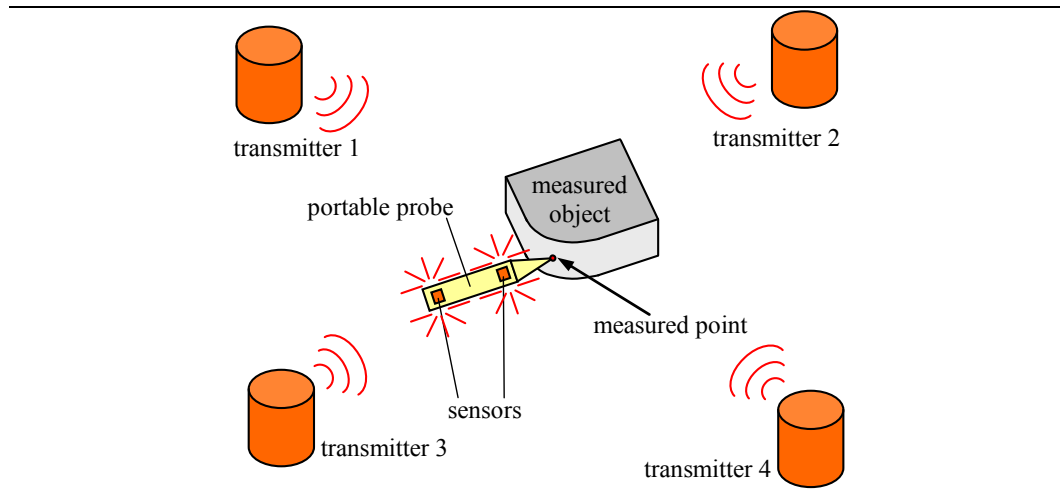

**Fig. 6.1.** Classification of large volume measuring instruments

iGPS is a modular, large volume tracking system enabling factory-wide localisation of multiple objects with metrologic accuracy, applicable in manufacturing and assembly. The system components of iGPS are a number of transmitters, a control centre, sensors and receivers [Kang and Tesar, 2004]. The distributed nature of the system eases the handling and provides scalability for the coverage of the measuring area. For this reason, iGPS is more suitable for particular types of measurement, which can not be carried out by conventional instruments, like Coordinate Measuring Machines (CMMs). For instance, some large-size objects can not be transferred to the measurement systems due to their dimensions or other logistical constraints. Therefore, it is required for the measurement system to be moved to such components. For the system operator, iGPS can potentially be considered as a faster and easier solution compared to conventional CMMs, theodolites or Laser Trackers.

Transmitters use laser and infrared light to determine the relative angles from the transmitters to the sensors. The sensors, used for measuring the workpiece, have photodiodes inside their modules that can sense the transmitted laser and infrared light signals (see Fig. 6.2). Based on the known location information of the transmitters, which is normally obtained in an initial *setup* phase, the position of the sensors can be calculated.

The signal is transferred through a wireless network connection providing mobility to the operator. Similar to a satellite-based GPS, a one-way signal path is created from transmitters to each sensor. This approach allows an unlimited number of sensors to continuously and independently calculate positional data.



**Fig. 6.2.** Representation scheme of an iGPS measurement and its portable probe

Measurements are taken by touching the required points on the object's surface with a probe that is equipped with double sensors. Points are defined on a Cartesian coordinate system; the coordinates are then processed by specific algorithms, in order to determine geometric features. Such measured features are then used to extract the desired dimensional information such as feature positions and angles between two features [ARC Second, 2004].

There are several standards for conventional dimensional metrology systems [ISO 10360, 2001; ANSI/ASME, 2006]. However, currently there are no international standards or best practice guide for the application of iGPS. For this, actually the system measuring performance is strongly dependent upon the system configuration (arrangement of the transmitters) and setup.

### 6.3 iGPS technology and operating features

Typically, system components of iGPS are two or more transmitters, a control centre and a number of wireless sensors.

Transmitters operate as reference points (with known position) continually generating three signals: two infrared laser fanned beams rotating in the head of the transmitter and

an infrared LED strobe [Maisano et al., 2008; Arc Second, 2004]. Sensors are passive elements, which can be placed on the surface of the object to be measured to receive the transmitters' signals.

iGPS is a *scalable* (or modular) system since the number of transmitters and sensors can be increased depending on the measurement environment. Such characteristics, however, do not compromise the network communication or slow down the setup activities and measurements [ARC Second, 2004].

Before starting measurements, the location of transmitters has to be determined. This phase should be fast and automated as much as possible to prevent any conflict with the system adaptability to different working environments.

During measurements, for each sensor the position  $(x, y, z)$  is calculated. Each transmitter presents two measurement values to each sensor: the horizontal (azimuth,  $\varphi$ ) and the vertical (elevation,  $\theta$ ) angles (see Fig. 6.3). Sensors can calculate their position whenever they locate in the line of sight of two or more transmitters. The principle used is triangulation [Niculescu and Nath, 2003].

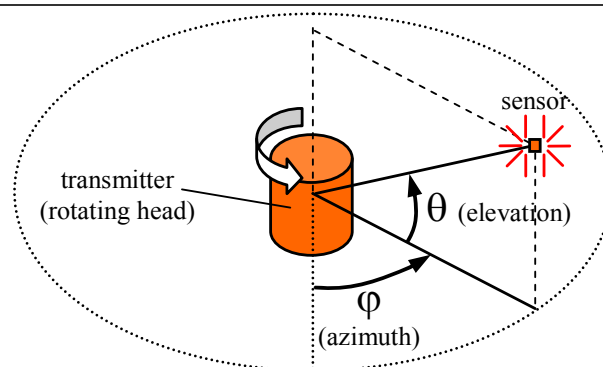

**Fig. 6.3.** Azimuth ( $\varphi$ ) and elevation ( $\theta$ ) angles from a transmitter to a sensor

Here follows a description of how sensors measure angles from the transmitters. Each transmitter generates two rotating infrared laser beams and an infrared LED strobe. These optical signals are converted into timing pulses through the use of a photo detector. The rotation speed of the spinning head in each transmitter is deliberately set to a different value in order to differentiate the transmitters. Additionally, the transmitter speed is continuously tracked and used to convert the timing intervals into angles. As shown in Fig. 6.4, the two fanned beams, radiated from the rotating head of each transmitter, are tilted with respect to the rotation axis (the vertical axis of the transmitter), nominally at  $-30^\circ$  and  $+30^\circ$ . This angular method is used to calculate the elevation angle by:

- knowing the angles of the fanned beams ( $\phi$  with respect to vertical as shown in Fig. 6.4);
- determining the difference in timing between the arrival of laser 1 and laser 2 to the sensor;
- knowing the speed of rotation of the transmitter, which is continually tracked.

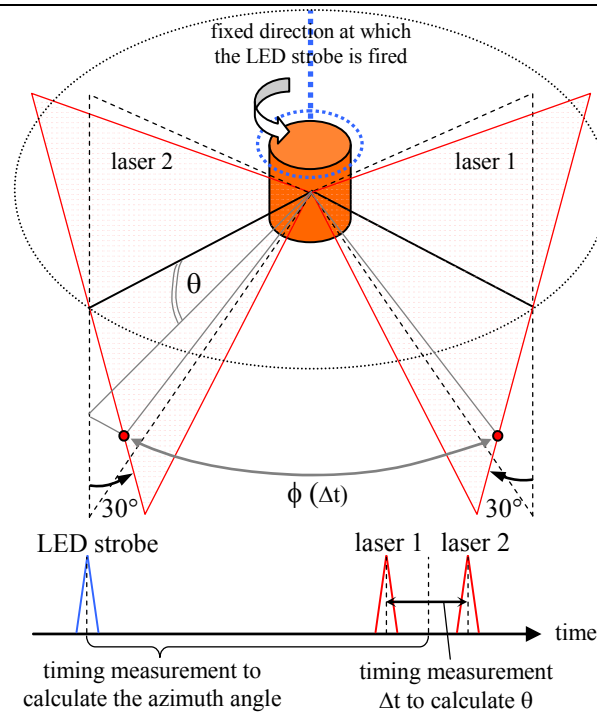

**Fig. 6.4.** Representation scheme of the transmitter's fanned beams [Metris, 2007]

The measurement of azimuth angle ( $\phi$ ) requires a horizontal index, which is created by firing an omnidirectional LED strobe at a fixed direction in the rotation of the transmitter's head. Referencing the timing diagram at the bottom of Fig. 6.4, the azimuth angle is determined by:

- knowing the angles of the beams;
- making a timing measurement between the strobe and the laser pulses;
- knowing the speed of rotation of the transmitter.

In addition to the azimuth and elevation angles from the transmitter to the sensor, more information is needed to perform a sensor position calculation, which is the relative position and orientation of the transmitters.

Transmitters make a *constellation* of reference points that are located through a system setup process. The relative position and orientation of the transmitters are determined using an advanced algorithm, which is known as bundle adjustment [Hedges et al., 2003; Chen et al., 2003]. An additional component of setup is to determine the system scale, which is the absolute distance between two known points such as the length of a reference bar. iGPS provides a relatively rapid and semiautomated localisation procedure, requiring relatively few manual measurements [Akcan et al., 2006].

Once the setup has been completed, the measurements can be performed using a portable handheld measurement probe, known as a V-bar. This probe is equipped with two sensors (Fig. 6.2 and Fig. 6.5) that should be carried by an operator in order to measure the coordinates of the points touched by the probe tip. To be stable and insensitive to thermal expansion, the portable probe is mainly made of composite material. For our initial experiments, the V-bar was used as a reference length (the inter-sensors distance is about 202 mm), in the transmitters localization procedure. As discussed in Section 6.4, the accuracy of transmitters location is influenced by the reference bar length. Regarding the future, this aspect will be studied in detail through a structured experimental plan.

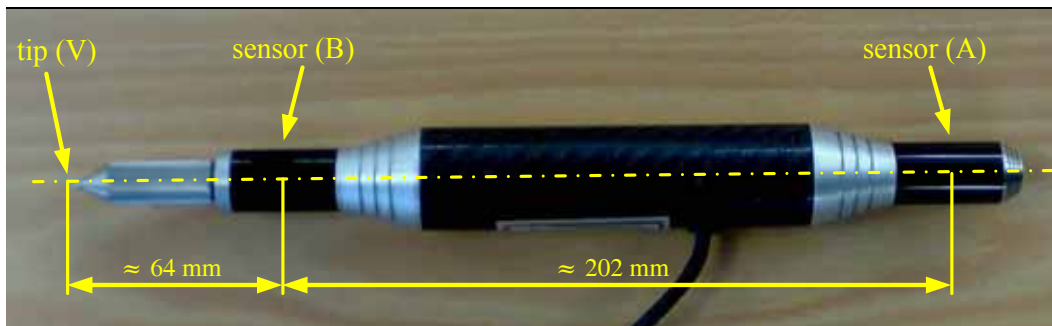

**Fig. 6.5.** iGPS portable hand-held measurement probe (V-bar)

In summary, the measurement procedure is made up of three main steps:

- Spatial location of each sensor is achieved using a triangulation technique. To uniquely determine the relative location of a point in a 3D space, at least two transmitters are needed [Chen et al, 2003; Akcan et al, 2006]. All information needed for the location is sent to a PC, for computing.
- As shown in Fig. 6.5, the probe tip (V) lies on the line that connects sensors A and B, similarly to the MScMS probe (Fig. 3.2). Therefore the location of the point touched

by the probe tip can be calculated using the coordinates of points  $A \equiv (x_A, y_A, z_A)$  and  $B \equiv (x_B, y_B, z_B)$  and the geometrical features of the probe (distances  $d_{V-A}$  and  $d_{A-B}$ ).

- Similar to CMMs and Laser Trackers, it is possible to determine or create new shapes and geometries of objects using the relevant software. The geometries include cylinders, planes, circumferences, cones, spheres, and any other standard features. This is achieved based on a set of measured points from the part surface. Such points are collected using the portable probe, and processed using the classical optimization algorithms [Overmars, 1997].

#### 6.4 Factors affecting measurement

During the tests performed many factors affecting the quality of measurement were identified and analysed. The most significant factors include:

- number of transmitters;
- movement of the sensors during measurement;
- location of transmitters (setup);
- environmental factors.

These will be individually analysed in the following paragraphs.

##### ***Number of transmitters***

The number of transmitters is strictly related to their communication range and the measurement volume. Since the communication range of each transmitter is around 30m, the transmitters' density within the measuring volume does not have to be high. For this experiment four transmitters are used, which cover a relatively large working area (about  $300\text{m}^3$ , considering a plant layout).

The influence of the number of transmitters "seen" by a sensor on its position error is analysed, using exploratory tests combined with simulation. These tests are useful to obtain preliminary indications. In the future, this effect will be studied in more detail, by means of a structured DoE (Design of Experiments). Actually, 30 points – with *a priori* known positions – are measured (averaging 150 repeated measurements per point) while the number of transmitters for the desired points is deliberately changed from 2 to 4 transmitters. Coordinates position errors (residuals) have been determined considering the difference between the *a priori* known coordinates' position, and the coordinates' posi-

tion of the points, calculated by triangulation. Then, the coordinates position errors related to all the 30 points are put together, showing a normally distributed pattern.

In the simulation experiment the effect of the number of transmitters is studied, varying the transmitters number from 2 to 8. The result showed to have a very large difference in performance between 2 and 3 transmitters. Passing from 3 to 4 transmitters, the improvement in the accuracy is still large. For 5 or more transmitters, improvement showed to be negligible. This behaviour is shown in Fig. 6.6, in which the standard deviations ( $\sigma_x$ ,  $\sigma_y$ ,  $\sigma_z$ ) related to the coordinates position errors are plotted based on the number of transmitters (from 2 to 8). We can notice that the position error standard deviations related to 2 and 3 transmitters are much larger than the ones related to 4 or more transmitters; in fact – considering the vertical axis – they plot out of scale. In these tests, the position of the 30 different measured points is assumed not to affect the coordinate position errors.

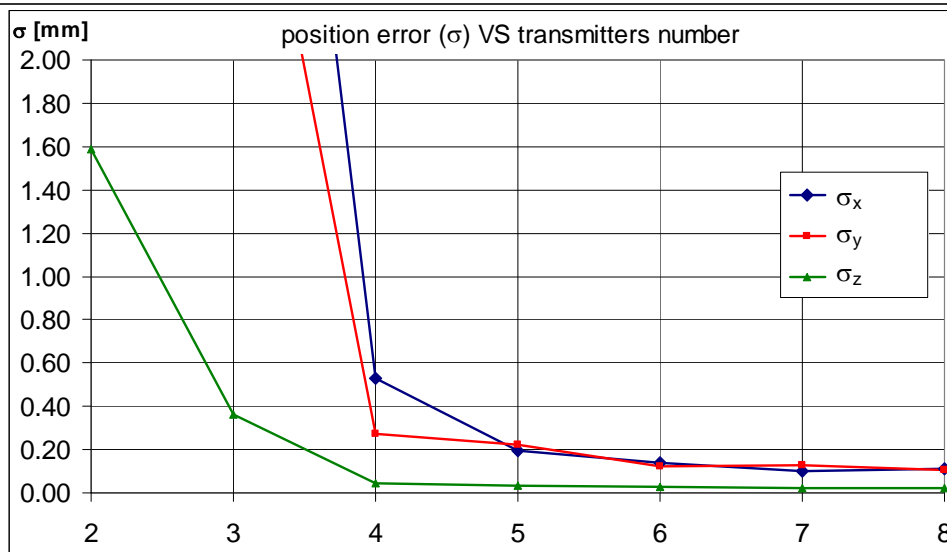

**Fig. 6.6.** Influence of the transmitters' number on the position error

For example, during the measurement by four transmitters, if the path between a transmitter and a desired sensor is accidentally blocked, and the sensor can only see three of the transmitters, the measurement quality will drop. This can happen when the line of sight between a sensor and one or more transmitters is obstructed by the operator or the workpiece body. Consequently, the transmitters should be arranged around the measuring area in suitable positions to gain maximum coverage (e.g. near the ceiling, to reduce the risk of obstructions). Regarding the future, some trials will be carried out, in order to

study the best way of positioning the transmitters, depending on the measured object and the measuring area.

### **Sensors' movement during measurement**

iGPS can be used to perform either static or dynamic measurements. In particular, during aircraft assembly operations, it can be useful to perform dynamic measurements. However, the system performs best in static measurement. This is due to the positioning method used. The position of each sensor can be calculated by triangulation using the two angles ( $\varphi$  and  $\theta$ ) from each transmitter. Transmitters sampling rate depends on the angular speed of their rotating heads. As explained above, the spinning speed is unique for each transmitter to be differentiated. Assuming the rotation speed is around 3000 rev/min, each transmitter will be able to communicate with sensors about  $3000/60=50$  times per second. Even though the transmitters sampling rate differences are small, it is impossible to receive concurrent data from all transmitters. The inevitable difference in data streaming is in the range of a few hundredths of a second. This effect does not create any problem for static measurements; however, it will affect the dynamic measurement. Fig. 6.7 shows such a scenario, in which sensors are moving in time ( $t$ ). For any sensor, the position at time period ( $t_4 - t_1$ ) is calculated by triangulating data collected in very close, but for different instants [Moore et al., 2004].

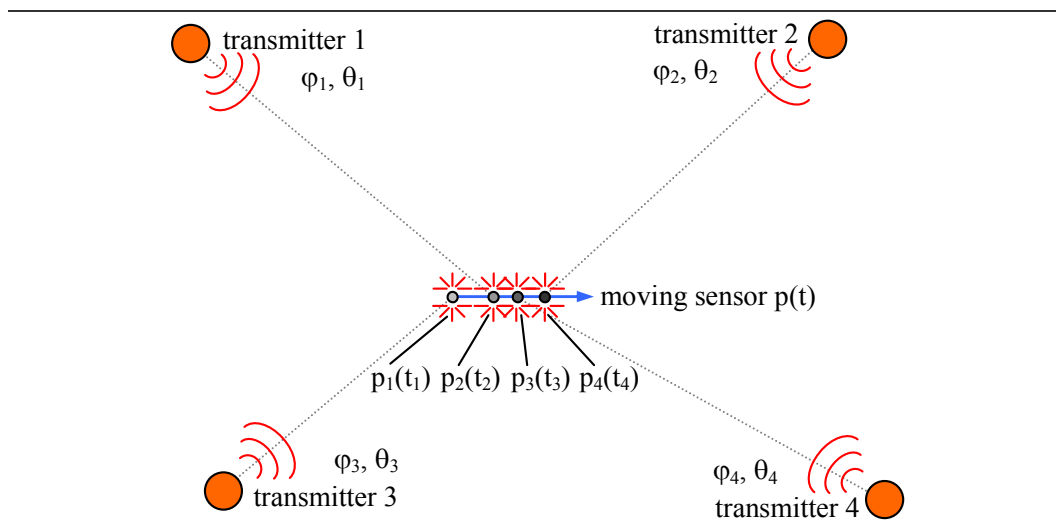

**Fig. 6.7.** If a sensor moves, data from transmitters are inevitably received in different instants

It can be assumed for the purpose of discussion that the data collection occurs by sensing information received firstly by transmitter 1, secondly by transmitter 2, thirdly by trans-



mitter 3 and finally by transmitter 4. At time  $t_1$ , a moving sensor's position is read when it is located in position  $p_1$ , at time  $t_2$ , when it is in position  $p_2$  and so on. Even if the difference consists of a few tens of a second, it produces a location error. Therefore, the faster the sensor moves, the larger the error becomes.

In this case the experiments for the system metrological performance were performed in static conditions, in order to avoid errors caused by the movements of the sensors.

### **Transmitters' location setup**

iGPS gives the opportunity of arranging transmitters in different ways, depending on the desired measuring area and the workpiece geometry. Every time the position of the transmitters is changed, a setup should be performed. Obviously, this step needs to be completed before performing measurements and its accuracy has strong effects on the accuracy of the measurements results [Patwari et al, 2005]. For this, iGPS software provides a semi-automated setup procedure that requires a few initial measurements that can be done manually or automatically, for example by a robot. During the setup procedure, the system scale is determined by placing two sensors at known distance within the measuring area, in at least 8 different positions and orientations. To that purpose, a reference bar of *a priori* known length can be used.

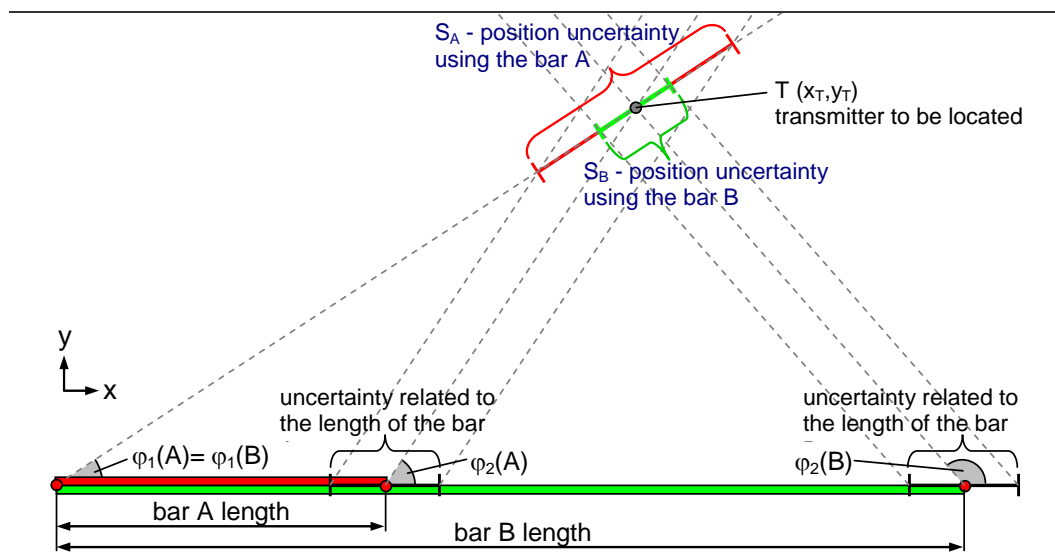

**Fig. 6.8.** Intuitive representation of the effect of the reference bar length on the transmitters' localisation error

When reference bars with different lengths, but similar uncertainties are used, longer reference bars normally generate better results in the above mentioned setup process

[Zakrzewski, 2003]. This can be intuitively explained by the simplified representation scheme shown in Fig. 6.8. Let us suppose that transmitter T ( $x_T, y_T$ ) is located in a plane (2D). The two angles ( $\varphi_1$  and  $\varphi_2$ ) from the sensors at the extremities of the reference bar and the bar length are known (assuming the uncertainty is null). Since there is an unavoidable uncertainty related to the bar length information, it will produce uncertainty in the location of the transmitter T. Considering the short bar (A) in Fig. 6.8, the uncertainty on the position of T is given by segment  $S_A$ . Using a longer bar (B), the location uncertainty decreases (see segment  $S_B$  in Fig. 6.8). This example shows that the longer the reference bar, the lower the uncertainty on the T location.

However, the use of too long reference bars is not practical and may produce other errors, which may inversely influence transmitters' location accuracy (e.g. flexing or thermal expansion of the bar, error related to the angles uncertainty).

### **Environmental factors**

iGPS, like most measuring instruments, is sensitive to several environmental factors, in particular temperature, light and vibrations. It is well known that laser signals are sensitive to changes in air conditions, especially in terms of temperature, which can exhibit both temporal and spatial variations within large working volumes. Light typically has a "go, no-go" effect, that is to say if sensors are exposed to light, the laser beams can be "obscured" and consequently measurements cannot be performed at all. To avoid this problem, for the experiments in this chapter, the lights in the laboratory are kept at minimum, especially in the area near to the sensors and transmitters. Vibrations are another source of error that can produce little movements of the measured workpiece or the measuring equipment. This effect can be large, and it should be considered when analysing the results.

To filter bad points from the measurement due to external factors such as light, temperature or vibrations, the iGPS software provides several diagnostic controls. The reliability of measurements increases significantly by using auxiliary sensors, which are placed in fixed positions at *a priori* known distances. With these sensors, the system can correct the initial setup in real-time, by compensating the changes in the environmental conditions of the measuring field, and determining whether the system is conforming to the desired tolerance [Kang and Tesar, 2004].

## 6.5 Experimental work for iGPS' preliminary performance analysis

Explorative tests are performed to evaluate the iGPS metrological performance in the following conditions:

- use of 4 transmitters;
- measuring area of about 60 m<sup>2</sup> (6x10 m, considering a plant layout);
- the system is setup using the mobile probe as a reference bar.

The iGPS performance has been initially estimated through three tests:

1. *Repeatability test.* In this test, a point within the working volume was measured repeatedly about 150 times to benefit from the high sampling rate of the instrument. During these measurements, the probe was left in a fixed position. The test was repeated for 30 different points in different areas of the working volume. For each point coordinate, the residuals between the single measurements and their average value were calculated. Then, for each Cartesian coordinate ( $x$ ,  $y$ ,  $z$ ) all the residuals from all the 30 points were put together. The residuals show a normally distributed pattern. The repeatability indicator is given by the standard deviations ( $\sigma_x$ ,  $\sigma_y$ ,  $\sigma_z$ ) related to each Cartesian coordinate residual (see Tab. 6.1).
2. *Reproducibility test.* This test was similar to the previous one, with the only difference being that the probe was replaced before each single point measurement. Hence, each point was approached from a different direction, using different orientations of the probe. Reproducibility gives a preliminary indication of the system's accuracy, whereas repeatability gives a preliminary indication of the target system's accuracy. This is based on compensating the most important causes of systematic errors. Tab. 6.1 shows the standard deviations related to each Cartesian co-ordinate. As expected, the standard deviations are higher than the repeatability tests.
3. *Accuracy test.* Accuracy of measurement is the "closeness of the agreement between the result of a measurement and the value of the measurand" [GUM, 2004; VIM, 2004]. This test was performed using a calibrated reference artefact with known dimensions [Cross et al., 1998]. The reference artefact consisted of two one meter bars assembled to create a two meter long reference bar. The reference bar was made of composite materials with different isostatic supports on which the mobile probe can be placed during measurement (see Fig. 6.9). The nominal dimensions of the artefact

(points' nominal position and nominal distances between points) are calibrated using a laser interferometer and a CMM, which are at least two orders of magnitude more accurate than the iGPS. These distance measurements are repeated by placing the artefact in 30 different positions and orientations within the measuring area. To reproduce a common measuring strategy, each point position is calculated by averaging 150 single position measurements. The standard deviation related to the distance residuals ( $\sigma_{\text{DIST}}$  in Tab. 6.1), that is to say the differences between nominal distances and distance measured with iGPS, is also calculated. Moreover, for each point coordinate, the residuals between the measured and the nominal position Cartesian coordinates are calculated. Then, the standard deviations related to the coordinates ( $\sigma_x$ ,  $\sigma_y$ ,  $\sigma_z$ ) are calculated. The residuals have been verified to be normally distributed. Based on these results, the iGPS uncertainty (referring to a  $\pm 2\sigma$  interval) can be roughly estimated to be less than 1 mm.

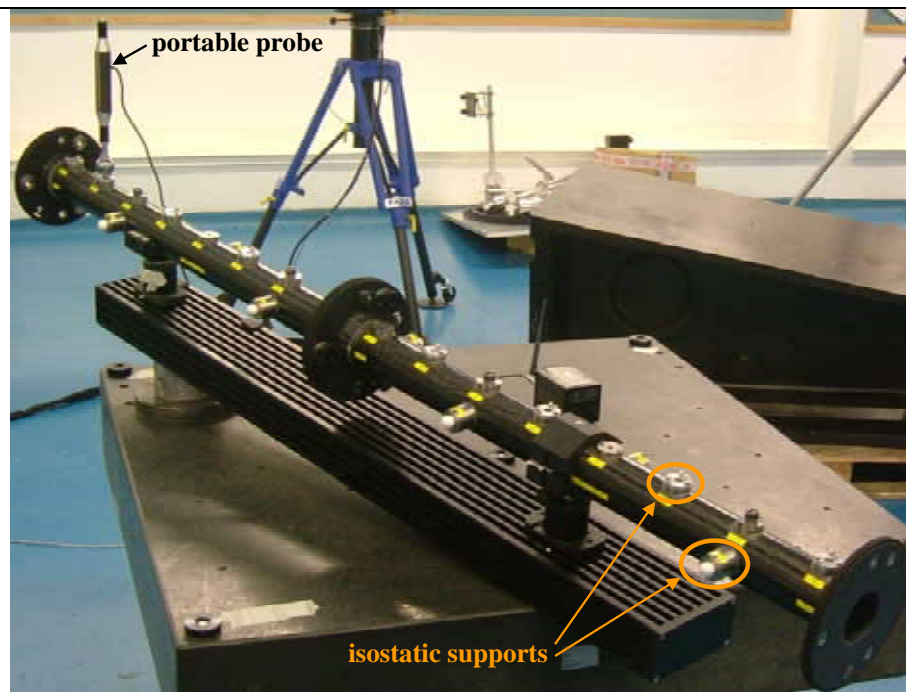

**Fig. 6.9.** National Physics Laboratory artefact [Cross et al, 1998], used for iGPS experiments

Results of these preliminary tests are reported in Tab. 6.1.

Considering the different testing conditions, these results are reasonably consistent with the results of some tests carried out by iGPS constructors [ARC Second, 2004]. In general,  $\sigma_z$  value is lower than  $\sigma_x$  and  $\sigma_y$ , for repeatability, reproducibility and accuracy

tests. This is due to the geometric configuration of the constellation devices as transmitters are mounted on tripods, which are set more or less at the same height. Therefore, they can be considered as approximately placed on a horizontal plane (XY) perpendicular to the vertical (Z) axis [Patwari et al., 2005].

**Tab. 6.1.** Results of the iGPS preliminary tests, performed in the specific testing conditions described in Section 6.5.

Test	<i>repeatability</i>			<i>reproducibility</i>			<i>accuracy</i>			
	$\sigma_x$	$\sigma_y$	$\sigma_z$	$\sigma_x$	$\sigma_y$	$\sigma_z$	$\sigma_x$	$\sigma_y$	$\sigma_z$	$\sigma_{DIST}$
Mean st. deviation [mm]	0.057	0.056	0.036	0.157	0.162	0.081	0.165	0.172	0.096	0.211

## 6.6 Systems comparison

In this section MScMS and iGPS are compared. The summary of the comparison and the results is given in Tab. 6.2.

**Tab. 6.2.** Comparison results between MScMS and iGPS

Technical feature	MScMS	iGPS
Measured variables	Distances among constellation devices	Two angles among each couple of sensor and transmitter
Localisation technique during measurements	Trilateration	Triangulation
Transmitter's communication range	Up to 6-8 m	More than 30 m
Number of constellation devices	1 per every $m^2$	4 or 5 per every $400 m^2$
Sample rate	About 3 points per second	About 50 points per second
Sensibility to environmental conditions	Temperature, humidity	Temperature, light, vibrations
Localisation of the constellation devices	Semi-automated procedure	Semi-automated procedure
System diagnostics	Diagnostic function to filter wrong measurements and to correct parameters	Use of fixed sensors to determine whether measurement system is going out of tolerance
System calibration check	Automatic calculation of the speed of sound during measurements	Real-time adjustments of the scale
Metrological performances	Position accuracy of about 10-20 mm (measurement of a single point by a single sampling)	Position accuracy of about 0.5 mm (measurement of a single point by averaging a number of scanned in 2 seconds)
Working volume size	Scalable	Scalable
Cost	Estimated at €10k	About €200k for a typical system with four transmitters

In the following paragraphs some of the previous results are individually analysed in order to emphasise the most interesting similarities and differences between the two systems.

#### ***Number of constellation devices***

For both MScMS and iGPS, the number of the constellation devices depends on their communication range and the measurement volume. In the case of MScMS, the experimental results showed that a coverage of an indoor working volume about 4 cubic meters large is achievable using at least one network device per square meter depending on the workshop layout. Comparatively, since the communication range of the transmitters of the iGPS is widely larger, the transmitters' density within the measuring volume is dramatically lower.

#### ***Sample rate***

With reference to the point collection frequency, MScMS and iGPS are very dissimilar. This difference depends on the speed of the exchanged signals between constellation devices and probe devices. The speed of US signals is about 340 m/s, while laser signals are considerably faster (~ 300,000 km/s). Consequently, MScMS sampling rate, which is about 2 points per second, is much lower than iGPS' that is about 50 points per second.

#### ***Localisation of the constellation devices***

MScMS and iGPS give the opportunity of arranging constellation devices in different ways, depending on the exigencies. Every time the systems are moved, that is, when the position of the constellation devices is changed, a localisation should be performed. Obviously, this step needs to be completed before performing measurements and has strong effects on the measurements accuracy. For this purpose, MScMS and iGPS provide two different semi-automated localisation procedures, both requiring few manual measurements.

#### ***System calibration check***

Another activity to make MScMS suitable for the measurement is the system calibration check. It is well known that the speed of sound changes with air conditions in terms of temperature and humidity, which can exhibit both temporal and spatial variations within large working volumes. As a consequence, the speed of sound should be often measured

and updated in the calculations. To real-time verify its value, an optimisation procedure is implemented.

A similar procedure is applied into iGPS, using a reference bar. What became clear from the tests is that iGPS's absolute uncertainty is directly related to the quality of the scale bar measurement and its initial calibration. The procedure can be fully automated using two fixed sensors, which are tied to the extremities of an interferometric scale bar. The implementation of auto-calibration minimises downtime and corrects for environmental conditions in the measurement field, continuously and in real-time.

### ***Metrological performances***

Results of preliminary repeatability and reproducibility tests to evaluate the performances of MScMS and iGPS are shown in Fig. 3.1. These tests are described respectively in Sections 3.3 and 6.5.

**Tab. 6.3.** Comparison between the MScMS and the iGPS metrological performances. The specific testing conditions described in Section 3.3 and Section 6.5

Test		<i>repeatability</i>			<i>reproducibility</i>		
Mean standard deviation [mm]		$\sigma_x$	$\sigma_y$	$\sigma_z$	$\sigma_x$	$\sigma_y$	$\sigma_z$
	MScMS	4.8	5.1	3.5	7.3	7.8	4.1
	iGPS	0.057	0.056	0.036	0.157	0.162	0.081

Due to its optical technology, iGPS metrological performance is considerably better than MScMS. Considering these results iGPS is approximately 2 orders of magnitude more precise than MScMS.

The technology employed, in particular the use of US transceiver to calculate the distances between the sensor devices, is responsible for MScMS's low accuracy compared to iGPS [Franceschini et al, 2008-II; Chen et al, 2003]. The US speed may change with the environmental conditions, depending on time and position. Furthermore, US signals may be diffracted and reflected by obstacles interposed between two devices. This is a negative effect for the measurement accuracy; however, it can be limited by the use of software compensation tools.

### ***Working volume size***

MScMS and iGPS introduce an important difference in the typologies of measurements. The big difference from the traditional frame instruments (like CMMs) is that their structure is not rigidly connected, but it is constituted by separate components that can be eas-

ily moved and arranged around the measuring area depending on the requirement. Therefore, these systems are *scalable* (or modular), since the number of constellation devices can be increased depending on the desired measurement environment. Such characteristics, however, do not compromise the network communication and do not slow down the activities such as constellation location and measurements.

### **System diagnostics**

MScMS is sensible to external factors, such as the environmental conditions of the measuring area (temperature, humidity, presence of obstacles among distributed devices). As mentioned above (Subsection 5.3.5), MScMS software provides some diagnostic tools to control the activities and assist in the detection of abnormal functioning. Wrong distance measurements, like the ones due to US reflection, diffraction, or other measuring accidents among Cricket devices, can be indirectly detected and rejected. To this purpose we have provided an effective diagnostic test, able to discriminate, with a little uncertainty, good from wrong distance measurements. This test is based on the analysis of the residuals related to the error function (EF) optimized during the trilateration process (see the description in Section 3.3) [Franceschini et al., 2007-II; Moore et al, 2004].

To filter bad measurements due to external factors as light, temperature or vibrations, iGPS also provides other types of diagnostic controls. The reliability of measurements dramatically increases by using multiple fixed sensors which are placed at *a priori* known positions. With these sensors the system can perform an automatic initial setup to continually correct the measurement field and determine whether the system is conforming to the desired tolerance [Kang and Tesar, 2004].

### **Cost**

Cost is a point in favour of MScMS, since its main components – including Cricket devices, supports and booms, adapters, etc. – have an individual cost of a few tens of euros. This reduces the overall cost of the system. On the other hand, the cost of iGPS, even for the most economical and simple configuration, is around 200,000 €.

## **6.7 Summary and final considerations**

The main issues and factors affecting the results of iGPS measurement are reviewed. The outline system performance in terms of repeatability, reproducibility and accuracy was



studied by initial experiments. According to the results that are obtained by averaging 150 readings for each point's measurement, the accuracy results are within 0.2 mm. This is achieved over a two meter length, however for real large scale metrology similar experiment should be repeated for larger size lengths, for instance 10 to 20m.

The result of measurement improves by increasing the number of transmitters – even if for 5 or more transmitters, improvement showed to be negligible – and also controlling the environmental effects like temperature gradients, vibrations or direct light. Also the quality of the initial system setup is a fundamental aspect.

It is also shown that with the existing technology, iGPS may not be completely suitable for dynamic measurements. However, by predicting the direction of movement and by using error compensation methods, this limitation may be resolved and iGPS could potentially be utilised for slow dynamic measurements.

MScMS and iGPS are compared, in order to highlight the pros and cons of each system, based on the experimental results and available information from the literature. In measurement activities, MScMS and classical iGPS are similar; however, they present many differences due to their different technological features. The technological differences affect several factors within the systems including system presetting, start-up and measurement execution. It can be concluded that these systems can easily coexist, since each system is suitable for specific applications due to their technological features. The metrological performance of iGPS is superior compared to MScMS, however, the overall cost of MScMS is more attractive in applications that do not require a higher level of accuracy. Both of these systems are lightweight, easily adaptable to different working environments, and can be rapidly installed and used. Prior to performing measurements, constellation devices are freely distributed around the area of work, and semi-automatically located in a few minutes.

Future work includes detailed experiments in order to more accurately characterise the advantages and weaknesses of the two systems. This will be done by designing several experiments that can be performed with the two systems under similar, controlled laboratory conditions.

Regarding the iGPS, a future research will deal with detailed analysis of the effects of the reference bar length used for the initial setup on measurement performance. This should lead to finding an optimal length of reference bar for bundle adjustment, to minimise the error in the transmitters' location. Also more detailed experiments will be done

in order to accurately characterise the system, depending on different types of setup strategies, and external conditions.



## 7. Future wireless sensor networks

### 7.1 Introduction

A wireless sensor network (WSN) consists of a large number of nodes with a dense distribution, equipped with sensor devices and transceivers. When networked together, these devices can provide high-resolution knowledge about sensed phenomena.

Due to dramatic advances in integrated circuits and radio technologies, networks of wireless sensors are more and more utilized for a variety of applications. While outdoor applications are widespread today – for example, consider the Global Positioning System (GPS) – several indoor applications can benefit from knowledge of location or other physical conditions of the environment investigated. Such applications span a wide range, including human and robotic navigation, people and objects tracking, traffic monitoring systems, environmental monitoring, logistics, industrial diagnostics, warehousing, quality control, and so on. In scientific research, there is a pressing interest around WSNs, because they are greatly innovative with regard to obtain information from the environment investigated [Patwari et al., 2005]. MScMS and the iGPS are two clear examples of innovative system based on WSN technology.

The aim of this chapter is to analyse the development of WSNs from a general point of view, trying to identify the most significant and innovative features, regarding the future. Discussing on opportunities improvements and development of WSNs, many question arise:

- “How WSN technology will expand?”;
- “Will future network devices and applications be standardized?”;
- “Will communication protocols change?”;
- “How the problem of power consumption will be approached?”;
- “How WSN will interface with the standard protocols (e.g. the Internet Protocol)?”.

This brief dissertation tries to identify and analyse some of the crucial aspects for the future, reviewing the significant literature on the subject. Section 7.2 provides a brief description of the general features, *modus operandi*, and requirements of WSNs. Section 7.3

provides a general discussion on potential and future development of WSN technology. Then, the attention focuses on two practical aspects which – probably – will be critical for future advancements:

- power consumption;
- standardization.

Final considerations are reported in Section 7.4.

## 7.2 Typical features of sensor networks

In order to prepare the field for the dissertation about WSNs future sceneries, this section summarizes their basic features, requirements, and *modus operandi*.

Sensor networks typically consist of a large number of nodes densely distributed. Each sensor node communicates with other nodes within its communication range. Silently and wirelessly, each sensor collects data, for instance, position estimates, monitoring of light, temperature, or other environmental factors. The collected data are relayed to its neighbouring devices and then to a specified destination where they are processed.

A wireless network is typically modelled as a graph, where each node represents a physical device. Two nodes are linked by an edge, if and only if they can directly communicate, or rather if they are *connected* (see Fig. 7.1). Sensory data, when gathered from all the devices and analyzed by more traditional computers, paint a comprehensive, high-resolution picture of the surroundings in real-time.

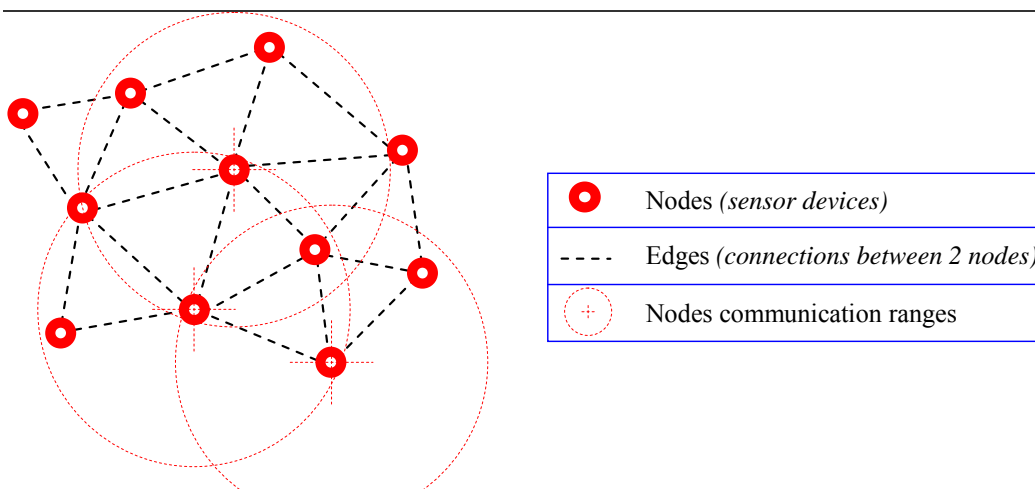

**Fig. 7.1.** Schematic representation of a wireless sensor network

WSNs can be utilized for a large number of purposes. Various requirements influence the design of sensor network:

A *scalable* network makes it easy to expand and contract its resources (nodes), independently from the performances. It is often advised to focus network design on hardware scalability rather than on capacity. It is typically cheaper to add a new node, in order to improve network performance, than to improve the capacity that each single node can handle. The potential size of future sensor networks will pose a great challenge with regard to the system scalability.

The combination of *small size*, *low cost* and wireless networking functionality makes sensor network technology exceptionally attractive. As prices become more accessible, scientists will be able to deploy many sensors simultaneously, with better proximity to the physical phenomena being monitored and more detailed tracking, leading to ubiquitous computing [Romer et al., 2002].

Another important requirement, for WSNs, is *self-configurability*. If sensor networks are to be widely deployed, setting them or extracting meaningful data must be simple. For example, in many applications knowing the physical location of network nodes is essential. To reach this purpose – since manual methods are tedious, especially for large-scale sensor networks – many self-localization methods have been recently studied and implemented. Moreover, in order to manage sensor hardware and software functionality, reliable and user-friendly standard operating systems should be designed and developed.

### 7.3 Growth potential and future advancement

Modern research on sensor networks started around 1980 for military purposes. The development of technology has been driven by advances in sensing, computation, communications, and – more in general – by the great expansion of ICT (Information and Communications Technology) – see Fig. 7.2. Current WSNs can exploit technologies not available 25 years ago and perform functions that were not even dreamed of at that time.

Sensors, processors, and communication devices are all getting much smaller and cheaper and WSN technology has enormous potential in terms of delivering new benefits to society [Intel, 2006]. WSNs can be used in many fields, ranging from environmental monitoring to industrial sensing, as well as traditional military applications. At the present time, several companies and manufacturers are studying the potential of WSNs in order to differentiate conventional products, and to be disruptive to competitors [Neil,

2005]. For example, *predictive-maintenance* service of conventional industrial equipments is a good opportunity to do just that, and it would be quite easily implemented with the emerging sensor-based wireless networking technology, which simplify the way manufacturers gather information. In this and other cases, WSNs can be seen as the key ingredient to allow the proliferation of new technologic solutions, which enhance the performances of existing products or processes.

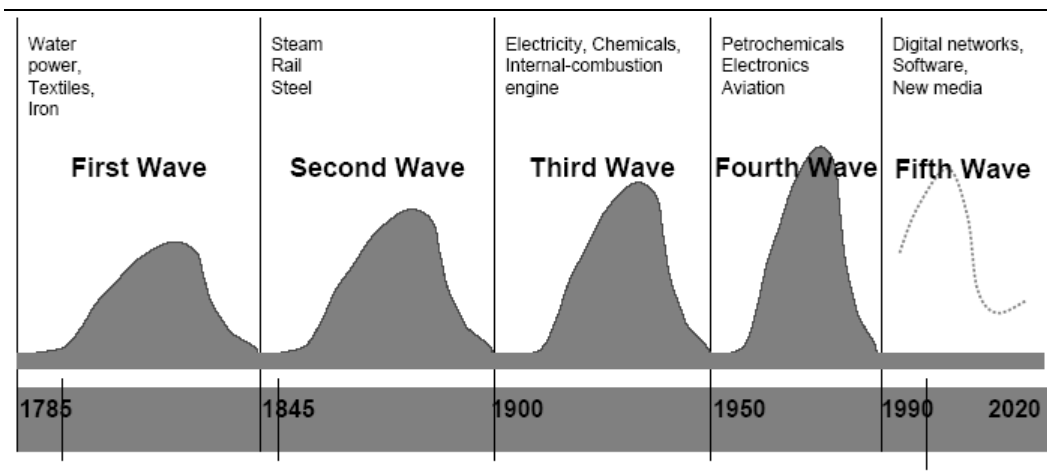

**Fig. 7.2.** The "waves" of innovation [Valery, 1999]

On the other hand, the industrialization process of WSN components is certainly in the early introduction phase and, as a consequence, develops very slowly. Several commercial companies – such as Ember, Crossbow, and Sensoria – are now building and deploying very different types of small sensor nodes [Sirbu et al., 2006].

As noted by Abernathy and Utterback, near the beginning of a new product market and before the emergence of a “dominant design” there is a great deal of product variety [Abernathy and Utterback, 1978]. At the turn of the 20th century automobiles came with internal combustion engines or steam engines, three four or five wheels, front steering or rear steering, and many other configurations before the dominant design of a four wheel vehicle with internal combustion, front wheel steering and rear drive wheels emerged. At the turn of the 21st century, we are in a similar place with sensor networks. Different vendors produce incompatible products of proprietary design. They have made very different choices in the design space, according to their respective competences, target market or limitations of the available technology. Standards, which define “dominant designs”, will gradually begin to emerge.

However, we have to state that – regarding the present – WSN applications are still in infancy, even if there has been a tremendous amount of work done towards solving research problems [Toh, 2004]. It is quite remarkable how little we have real, mass-market, wireless *ad hoc* products available, taking into account the massive amount of research done. Oversimplifying and somewhat exaggerating, networking research has been more strongly technology-push related, and apart of few special cases (such as military networks) there is only a limited number of well-recognized and accepted application cases [Chai-Keong et al., 2005].

It is not easy to forecast the future of WSNs, due to the great abundance of industrial areas of interest, but – at the same time – the lack of “tangible strategies” to transfer the best new ideas onto the market by demonstrating benefits to both users and the company that provides those benefits [Weiss, 2002]. Some experts’ opinion is that sensor networks could potentially become a disruptive technology when the miniaturization, power consumption, standardization and cost problems are solved. The last two of these issues are discussed in the following of the chapter.

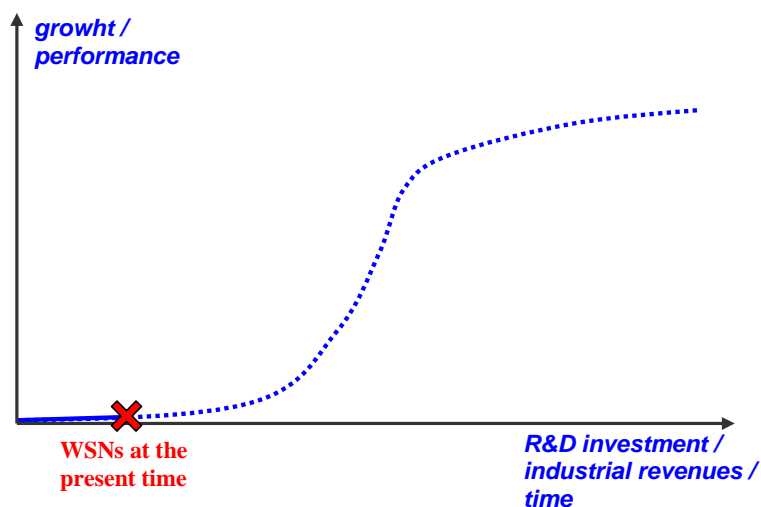

**Fig. 7.3.** Estimated s-curve for WSNs technology

In general, the life cycle of innovation for a generic product or technology can be described using the ‘s-curve’. The s-curve maps growth of revenue, performance or productivity against investment or time (see Fig. 7.3). In the early stage of a particular innovation, growth is relatively slow as the new product/technology establishes itself. At some point customers begin to demand and the product/technology growth increases exponen-



tially. New incremental innovations or changes to the product/technology allow growth to continue. Towards the end of its life cycle growth slows and may even begin to decline.

Focusing on WSNs life cycle, we estimate it to be in a start-up phase, because WSN products are, at this time, entering the market very slowly (see Fig. 7.3). Much more effort should be taken to make WSNs technology popular and widely implemented.

As wireless sensor networks are still a young research field, much activity is still ongoing to solve many open issues, before WSNs will be ready for practical deployment [Karl and Willig, 2003]. In next paragraphs we discuss two aspects which certainly will be critical for future advancements. They respectively are: *power consumption* and protocols and components *standardization*.

### **Power consumption**

Since network nodes should be tiny, unobtrusive, low cost, and wireless, they can carry only a small battery as energy supply. As a result, low-power operation is a must, and computational and communication capabilities are limited.

Many devices that are broadly defined as *wireless*, because of their method of data transmission, are not truly wireless in that they may require hardwiring to an AC power source. In remote sensor installations, however, it is often impossible or expensive to connect to the power grid. In situations where a self-contained power supply is required, design engineers have traditionally relied on two options: primary lithium battery power or photovoltaic systems with rechargeable batteries [Warrior, 1997].

Photovoltaic systems are naturally suited to sunny, temperate climates, but they tend to be large, comparatively expensive, and susceptible to breakage, and they require ongoing maintenance. Their use in indoor environment or inaccessible areas is therefore problematical.

Lithium batteries are the preferred choice for most remote sensing applications because they have the highest specific energy and energy density (energy per unit volume) of all battery types.

Even if increases in chip capacity and processor production capabilities have reduced the energy requirement for both computing and communication, regarding the future an important goal is to reduce the need for battery changeouts over long periods (i.e. months or years). It will reduce maintenance and operating costs, resulting in a higher return on investment and a most efficient use of sensor network resources.

In order to meet this target, there are two different research directions:

*1. New generation battery types.* With new applications seemingly cropping up on a daily basis, and sensing devices becoming increasingly feature rich and power hungry, design engineers are sending a wakeup call to battery manufacturers for innovative solutions such as hybrid lithium battery technologies, or – even more – hydrogen fuel-cells [Jacobs, 2004]. Recently, great attention is focused on miniature fuel-cell, because they can store a lot more energy than other standard cells, making it possible to supply portable devices for long [Graham-Rowe, 2005].

In a few years, networked sensors and actuators will outnumber traditional electronic appliances. They will enable a plethora of new services and applications in industrial automation, asset management, environmental monitoring, medical and transportation business, and in a variety of safety and security scenarios. In these conditions, sensor and actuators, or low-power devices – requiring only intermittent connectivity – should be able to operate on batteries for months or years.

*2. Energy efficient routing protocols.* Another approach to reduce power consumption is to develop energy efficient routing protocols for communication among network nodes. Traditional routing protocols have not been designed for such exigency. Researchers are working on novel light-weight messaging protocols that do not rely on full TCP/IP connectivity and are capable of operating directly over low-power wireless protocols. Since communication is significantly more energy-expensive than computation, this purpose seems very reasonable. In other terms, because of energy and bandwidth constraints, WSNs pose additional technical challenges in network control and routing, collaborative information processing, querying, and tasking [Chee-Yee Chong, 2003]. Energy efficient routing protocols are based on two strategies, which are not conflicting, but rather they can be implemented in conjunction, in order to increase energetic autonomy of network devices: (a) broadcasting economization, (b) uniform spreading of the network traffic [Schurgers, 2001].

(a) The first strategy suggests to combine/fuse data generated by different sensors, in order to reduce the number of packets sent among nodes. In practical terms, neighbouring nodes are grouped in local clusters. Each cluster broadcasts to others only when it collects a certain amount of data from the nodes which includes. This process makes it possible to reduce significantly the network traffic and save energy. Additionally, it enhances communication capability, because data can be compacted as they contain partly the same information. The drawback of this method is the average

delay per packet. Undoubtedly, it would directly increase with the minimum amount of data, collected by each node before transmission. Whether or not this is acceptable depends on the application.

(b) The second strategy focuses on the network paths followed during the data routing phase, for transmitting information among nodes. Since every network node can only communicate to its immediate neighbours, data packets travel through the mesh of connections in a peer-to-peer manner (see Fig. 7.4). Typically, the routing paradigm used refers to shortest path or minimum hop.

Generally, energy consumption is not uniformly distributed, because some network nodes – e.g. peripheral nodes – hardly communicate, while others – e.g. central nodes – are congested and tend to drain their energy very quickly. It should be noted that nodes which die sooner limit the lifetime of the entire network. Innovative routing protocols try to provide a more uniform resource utilization, shaping the traffic flow depending on battery reserve. The innovative concept consists in allowing distribution of the message traffic across several message channels, so that traffic flows over less congested ones. For example, when a node detects that its energy reserve has dropped below a certain threshold, it discourages other nodes from sending data to it. The goal is to choose routes comprising a minimum number of nodes with sufficient remaining power.

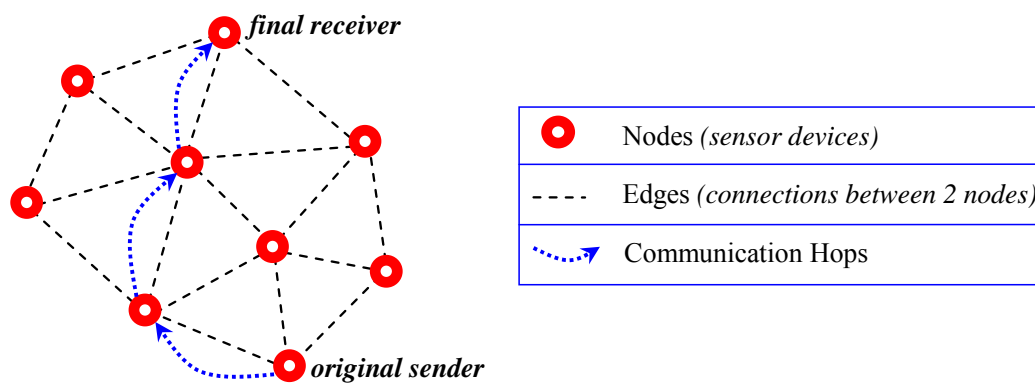

**Fig. 7.4.** Schematic representation of data transmission among network nodes

### **Standardization**

Most of the research in WSN field has been more technology-push driven than trying to specify clear requirements from applications. Today, there are different networking de-

vices and protocols, supported by research bodies which attempt to define standard combinations of technology and functionality, in order to allow devices to interoperate with each other. WSN devices are often chosen to fulfil some specific projects or partnership requirements. In this scenario, there is no strong standardization organization that is specifically aiming to harmonize interfaces and interoperability functionalities for WSN systems [Romer et al., 2002].

The industrial exploitation and research challenge is to find out enough commonalities to build more generic platforms, architectures and standards, providing common ground for the future, instead of collecting different approaches. Although unlimited technology-push is often required to develop disruptive technologies, it is also inevitable that some standardization and cases of industrial use will help on stabilizing field, bootstrapping industrial exploitation and to attract early adopters [Toh et al., 2005].

In the following discussion, we briefly present two research issues and challenges for standardization. They are: (1) components standardization, and (2) protocols standardization.

*1. Components standardization.* There are different possible approaches to standardize WSNs components.

A first approach consists in creating a catalogue of standard parts that can be used. Implementers must ensure that their products conform to specifications. The main drawback is that such a catalogue will often be out of date and incomplete. In addition, the specifications attempt to regulate the architecture of network devices could result counterproductive, because it could discourage the development of innovative and unconventional architectures [Crater, 1992].

Another approach for standardization is based on object-oriented design principles. The idea is that each sensor is independent of the microprocessor to which it is attached by specifying a digital interface and digital data sheet stored on the sensor. This would allow any sensor to be connected to any network-connected device. Object-oriented design principles ensure sensors interoperability, leaving open details of implementation.

A third similar approach, suggested by IEEE (Institute of Electrical and Electronics Engineers) – makes sensor devices independent of the protocol used on the network [IEEE P1451.1, 1999]. Considering this point of view, sensor devices should be “smart” and “plug and play”. The idea is similar to that of writing a word processing program that must be able to print under an operating system such as Windows. The application deals

with the printer at a high level of abstraction – and by loading the appropriate printer driver – the application can print on different kinds of printers with no changes to the application itself.

*2. Protocols standardization.* With the maturation of networking technology, you can choose any one of the many different protocols developed so far, to build a networked sensor application. The choice of which one to use is not dictated so much by the technical features of the protocol as by other considerations, such as the protocols compatibility with a particular network technology or the availability of an application or software package with that technology [IBM Research, 2005]. There are different possible approaches for standardization of WSN protocols.

A first standardization approach is suggested by IEC (International Electrotechnical Commission) – which attempts to provide a standard set of programming languages for WSN applications [IEC 1131 part 3, 1993]. IEC Committee hopes that the use of such standard languages will make program code portable from one device to another, independently from hardware features of network devices.

Another standardization strategy is to extend the existing Internet Protocol (IP) to WSNs. In other terms, the aim is to connect WSNs to the existing Internet. Any network, wishing to be connected to the Internet, needs to address the question of how it will interface with the standard protocols like the Internet Protocol. The characteristics of WSNs differentiate them from traditional IP-based networks: chief among these are WSNs large-scale unattended systems consisting of resource-constrained nodes that are best-suited to application-specific, data-centric routing. These fundamental differences rule out the possibility of all-IP sensor networks and recommend the use of application-level gateways or overlay IP networks as the best approach for integration between WSNs and the Internet.

## **7.4 Final considerations**

The development of sensor networking technology has been driven by advances in sensing and computation, and these technologies have been integrated by innovations in communications. Providing reliable wireless connectivity, self-configurability and scalability, while at the same time coping with the limitations imposed by low-cost, energy-supply, miniaturization, and standardization of sensor nodes, presents a multitude of challenging research problems.

---

This chapter provided various perspectives related to wireless sensor networking research, trying to identify and analyse the potential and the crucial aspects for future. Some experts' opinion is that sensor networks could potentially become a disruptive technology when the miniaturization, power consumption, standardization and cost problems are solved.

WSNs are still a young research field, much activity is still on-going to solve many open issues before their will be ready for an important practical deployment.



## 8. Conclusions and future directions

This final chapter describes the primary contributions of this thesis and the possible future research developments.

### ***MScMS Prototype***

A preliminary prototype of MScMS was built and tested with the purpose of verifying system feasibility and to evaluate its performances.

The system is adaptable to different working environments, and does not require long installation or start-up times. Before performing measurements, constellation devices – freely distributed around the measuring area – locate themselves by means of a semi-automatic procedure. System is supported by an *ad hoc* software – created in Matlab – to drive user through measurements and online/offline elaborations.

Actually, measurements consist in:

- touching the desired points on the measurand surface by using a mobile probe;
- pulling the probe trigger for performing the measurement and sending the information via Bluetooth to the PC;
- calculating the Cartesian coordinates ( $x, y, z$ ) of the points by specific algorithms and eventually identifying the geometrical features of the measurand surface.

The prototype actual performance was estimated by two practical tests: repeatability and reproducibility. Regarding the repeatability test, the average standard deviations ( $\sigma_x, \sigma_y, \sigma_z$ ) related to the point Cartesian coordinates are around 5 mm. Regarding the reproducibility test, they are around 7 mm. This low metrological performance is the actual Achilles' heel of MScMS. This is mainly due to the use of ultrasound transceivers (non punctiform dimension, speed of sound dependence on environmental factors, use of the threshold detection method for detecting the US signal etc..). As research perspectives, all factors affecting system accuracy should be analysed in detail, with the aim of compensating them or reducing their effect.

Furthermore – even if this topic is not fully discussed in this thesis – MScMS offers the possibility of simultaneously performing different kinds of measurement (light, acous-



tic noise, pressure, temperature, acceleration, magnetic field and humidity, gas concentration), associating them to the position measurement. These kinds of measurement, which can not be achieved with a classical CMM, are useful for the mapping of indoor environments [Fischer et al., 2001; Lilienthal and Duckett, 2004; Safigianni et al., 2005].

### ***MScMS ultrasound transducers***

With regard to the TOF measured by the US transducers equipping MScMS, an exploratory analysis of the most important sources of error has been performed. The result is that the most important effects are due to the US signal attenuation, which is directly caused by the implementation of the thresholding signal detection method [Figuroa and Lamancusa, 1992]. The three major sources of attenuation are (1) transceivers distance, (2) transceivers misalignment angle, (3) transducer battery charge level. These factors have been analysed through an organic experimental factorial plan. According to the results, transceivers distance and misalignment angle are the most significant.

Unfortunately, the actual metrological performance of MScMS is strongly limited by the measuring errors derived by the use of US transceivers. Regarding the future, the system's accuracy could be improved implementing more refined US ranging methods, for example based on phase-detection with fixed-frequency signals and with frequency-modulated signals [Manthey et al., 1991; Tong et al., 2001]. The main drawback is that these detection methods are more expensive, because they require complex hardware/software. Another possible solution to the error derived by the transmitter misalignment is the use of omni-directional ultrasonic transducer, like the cylindrical polyvinylidene fluoride (PVDF) film transducers [Toda, 2002]. But here again, Cricket devices should be partially redesigned, either from the hardware and the software viewpoints. Other techniques for compensating the measurement error are not easy to be implemented because of the difficulty in simultaneously controlling all the factors producing the US signal attenuation.

### ***Comparison between MScMS and CMMs***

MScMS was compared to the classical CMMs, the most commonly used equipments for objects dimensional measurements. Considering measurement activities, MScMS and classical CMMs are similar. However – due to their different technological features – they have many differences (for example system presetting, start-up, measurement

execution, etc...). The lower accuracy of MScMS makes it difficult to compete with CMMs when it comes to measuring small-size objects. On the other hand, MScMS becomes competitive in the dimensional evaluation of large-size workpieces, where is convenient to move the machine to the place where the object is and where the required level of accuracy is not very high.

### ***iGPS performance and comparison with MScMS***

The main issues and factors affecting the quality of iGPS measurement were reviewed. The introduction of the iGPS and other measuring systems based on distributed components may have important effects on simplifying the current measuring practices within large scale industrial metrology. For iGPS, it is shown that the result of measurements improves by increasing the number of transmitters and also controlling the environmental effects like temperature gradients, vibrations or direct light. Also the quality of the initial system setup is a fundamental aspect. It is also shown that with the existing technology, iGPS may not be completely suitable for dynamic measurements. However, by predicting the direction of movement and by using error compensation methods, this limitation may be resolved and iGPS could potentially be utilised for slow dynamic measurements.

Furthermore, MScMS and iGPS are compared, in order to highlight the pros and cons of each system, based on the experimental results. In measurement activities, MScMS and classical iGPS are similar. At the same time, they present many differences due to their different technological features. Both of these systems are lightweight, easily adaptable to different working environments, and can be rapidly installed and used. Prior to performing measurements, constellation devices are freely distributed around the working area and located performing a semi-automatic procedure.

The iGPS performance in terms of repeatability, reproducibility and accuracy has been studied by initial experiments. According to the results, iGPS repeatability and reproducibility are approximately two orders of magnitude better than the MScMS'. However, the overall cost of MScMS is more attractive in applications that do not require a higher level of accuracy.

Regarding the iGPS, a future research will deal with detailed analysis of the effects of the geometry of the reference artefact used for the initial setup on measurement performance. This should lead to finding an optimal geometry to minimise the error in the transmitters' location. Also more detailed experiments will be done in order to accurately

characterise the system, depending on different types of setup strategies, and external conditions.

### ***Evolution of the wireless sensor networks***

Finally, the attention was focused on the wireless sensor networking technology, from a general point of view. This technology has been driven by advances in sensing and computation, and has been integrated by innovations in communications. MScMS and the iGPS are two clear examples of innovative system based on WSN technology.

Providing reliable wireless connectivity, self-configurability and scalability, while at the same time coping with the limitations imposed by low-cost, energy-supply, miniaturization and standardization of sensor nodes, the field of distributed sensor networks presents a multitude of challenging research problems.

For the MScMS future development, two critical aspects are the miniaturization of the US transducers and the improvement of the constellation devices power efficiency.

### ***Future directions***

Future work on this project includes:

- Analysis, comparison and improvement of different possible techniques for the location of constellation devices. Three semi-automatic algorithmic procedures will be evaluated and compared through computer simulations and experimental validation tests.
- Development of an *ad hoc* software “pre-processor” in order to guide the operator in positioning the constellation devices around the working volume, according to the dimensional characteristics of the measured object. Such a tool would be helpful for determining a proper alignment of constellation devices and guaranteeing a full coverage of the measuring area.
- Automatic mapping of indoor environments. Different kinds of measurement (light, acoustic noise, pressure, temperature, acceleration, magnetic field, humidity etc.) can be associated to positional measurements. It can be obtained by equipping the measuring probe devices with additional sensor boards. Then, measuring operations can be automated by mounting the probe on a robotized vehicle.
- Enhancement and redesign and of the Cricket devices, either from the hardware and the software viewpoints. The most important issues are the miniaturization of the US trans-

---

ducers and the implementation of more refined US ranging methods, for example based on phase-detection.



## References

- ABERNATHY, W.J., UTTERBACK J. (1978) Patterns of Industrial Innovation. *Technology Review*, Vol. 80, No. 7, pp. 40-47.
- AKCAN, H., KRIAKOV, V., BRÖNNIMANN, H., DELIS A. (2006) GPSFree Node Localization in Mobile Wireless Sensor Networks. In *Proceedings of MobiDE'06*, Chicago, Illinois, USA.
- ANSI/ASME B89.4.19-2006 (2006) Performance Evaluation of Laser-Based Spherical Coordinate Measurement Systems
- ANSI/IEEE STD. 176-1987 (1988) Standard on Piezoelectricity. American National Standards Institute, New York.
- ARC SECOND (2004) "Product Literature", <http://arcsecond.com>.
- BALAKRISHNAN, H., BALIGA, R., CURTIS, D., GORACZKO, M., MIU, A., PRIYANTHA, N. B., SMITH, A., STEELE, K., TELLER, S., WANG, K. (2003) Lessons from Developing and Deploying the Cricket Indoor Location System. Preprint.
- BERNERS, A.C., WEBSTER, J.G., WORRINGHAM, C.J., STELMACH, G.E. (1995) An ultrasonic time-of-flight system for hand movement measurement. *Physiological Measurement*, Vol. 16, pp. 203-211.
- BOHN, D. A. (1988) Environmental Effects on the Speed of Sound. *Journal of the Audio Engineering Society*, Vol. 36, No. 4.
- BOSCH, J. A. (1995) *Coordinate Measuring Machines and Systems*, Edited by Marcel Dekker, Inc. ISBN 0-8247-9581-4.
- BOX, G.E.P., HUNTER, W.G., HUNTER, J.S. (1978) *Statistics for Experimenters*, Wiley, New York.
- CAPKUN, S., HAMDI, M., HUBAUX, J. P. (2001) GPS-free positioning in mobile ad-hoc networks. In *Proceedings of the 34th Hawaii International Conference on System Sciences*.
- CHAI-KEONG, MAHONEN, P., UUSITALO, M. (2005) Standardization Efforts & Future Research Issues for Wireless Sensors & Mobile Ad Hoc Networks. *IEICE Trans. Commun.*, Vol. E88-B, No. 9, pp. 3500-3507.
- CHEE-YEE CHONG, KUMAR, S.P. (2003) Sensor networks: Evolution, opportunities, and challenges, *Proceedings of the IEEE*, Vol. 91, No. 8, pp. 1247-1256.
- CHEN, M., CHENG, F., GUDAVALLI, R. (2003) Precision and Accuracy in an Indoor Localization System. Technical Report CS294-1/2, University of California, Berkeley, USA.
- CRATER, K. C. (1992) When Technology Standards Become Counterproductive. <http://www.ctc-control.com/tutorials/language/counter.htm>.
- CROSS N. R., DOTSON J. R., FLANK D. R., PEGGS G. N, COX M.G., FORBES A.B., CORTA R., O'DONNELL J. AND PRIETO E., (1998) "A Large Reference Artefact for CMM Verification", National Physical Laboratory, NPL Report CLM 6, May 1998.

- CROSSBOW TECHNOLOGY (2008) <http://www.xbow.com>.
- CURTIS, M. A., FARAGO, F. T. (1994) Handbook of dimensional measurement, third edition, Industrial Press Inc., New York.
- DEA (2007) <http://www.dea.it>.
- DELEPAUT, C., VANDENDROPE, L. AND EUGÈNE, C. (1986) Ultrasonic three-dimensional detection of obstacles for mobile robots. In Proceedings of 16th International Symposium of Industrial Robots (ISIR 86 Brussels), pp. 483-90.
- DOSS, R.C., CHANDRA D. (2005) Reliable Event Transfer in Wireless Sensor Networks Deployed for Emergency Response. In Proceedings of the 17th IASTED International Conference on Parallel and Distributed Computing and Systems PDCS 2005, Phoenix, AZ, USA.
- FIGUEROA, J.F., LAMANCUSA, J. (1992) A method for accurate detection of time-of-arrival- analysis and design of an ultrasonic ranging system. Journal of Acoustic Society of America, Vol. 91, No. 1, pp. 486-494.
- FISCHER, M.L., PRICE, P.N., THATCHER, T.L., SCHWALBE, C.A., CRAIG, M.J., WOOD, E.E., SEXTRO, R.G., AND GADGIL, A.J. (2001) Rapid Measurements and Mapping of Tracer Gas Concentrations in a Large Indoor Space. Atmospheric Environment, No. 35, pp. 2837-2844.
- FURUTANI, R., KAMAHORA, K. (2001) Development of a new artefact for the calibration of large scale instruments. Measurement, Vol. 30, No. 2, pp. 139-143.
- FRANCESCHINI, F., GALETTO, M. (2007) A taxonomy of model-based redundancy methods for CMM on-line performance verification, International Journal of Technology Management 2007, Vol. 37, No.1/2 pp. 104-124.
- FRANCESCHINI, F., GALETTO, M., MAISANO, D. (2007-I) Management by Measurement: Designing Key Indicators and Performance Measurement Systems, Springer Verlag, Berlin, DOI: 10.1007/978-3-540-73212-9.
- FRANCESCHINI, F., GALETTO, M., MAISANO, D., MASTROGIACOMO L. (2007-II) On-line diagnostics tools in the Mobile Spatial coordinate Measuring System (MScMS). Forthcoming in Precision Engineering, DOI: 10.1016/j.precisioneng.2008.11.003.
- FRANCESCHINI, F., GALETTO, M., MAISANO, D., MASTROGIACOMO L. (2008-I) A Review of Localization Algorithms for Distributed Wireless Sensor Networks in Manufacturing. Forthcoming in International Journal of Computer Integrated Manufacturing, DOI: 10.1080/09511920601182217.
- FRANCESCHINI, F., GALETTO, M., MAISANO, D., MASTROGIACOMO, L. (2008-II) Mobile Spatial coordinate Measuring System (MScMS) - Introduction to the system. Forthcoming in International Journal of Production Research, DOI: 10.1080/00207540701881852.
- FRANCESCHINI, F., GALETTO, M., SETTINERI, L. (2002) On-Line Diagnostic Tools for CMM Performance. The International Journal of Advanced Manufacturing Technology, Vol. 19, No. 2, pp. 125-130.
- GOTSMAN, C., AND KOREN, Y. (2004) Distributed Graph Layout for Sensor Networks. In Proceedings of Graph Drawing 12th International Symposium, New York, Vol. 3383/2005 pp. 273-284.
- GRAHAM-ROWE, D. (2005) Compact fuel cells may oust feeble batteries. New Scientist, 1st October 2005.

- GUM (2004) "Guide to the Expression of Uncertainty in Measurement", International Organization for Standardization, Geneva, Switzerland
- GUSTAFSSON, F., GUNNARSSON, F. (2003) Positioning using Time Difference of Arrival measurements. Proceedings of the IEEE International Conference on Acoustics, Speech, and Signal Processing (ICASSP 2003), Hong Kong, Vol. 6, pp. 553-556.
- HEDGES, T.H., TAKAGI, H., PRATT, T., SOBEL, M.J. (2003) Position measurement system and method using cone math calibration. US Patent 6,535,282 B2 of March 18th, 2003.
- IBM RESEARCH (2005) Wireless sensor networking - Innovation Matters.
- IEC 1131 part 3 (1993) Programmable controllers, Part 3: Programming languages (Standard IEC 1131-3), August 1993.
- IEEE P1451.1 D2.25 (1999) Draft Standard for a Smart Transducer Interface for Sensors and Actuators - Network Capable Application Processor (NCAP) Information Model," Institute of Electrical and Electronics Engineers, Inc., Piscataway, New Jersey, January 25, 1999.
- INTEL CORPORATION (2005) Expanding Usage Models for Wireless Sensor Networks. Technology@Intel Magazine, <http://www.intel.com/technology/magazine/research/sensor-networks-0805.pdf>.
- INTEL (2006) Improving Life and Industry with Wireless Sensors, [http://www.intel.com/research/exploratory/wireless\\_promise.htm](http://www.intel.com/research/exploratory/wireless_promise.htm).
- ISO (1993) International Vocabulary of Basic and General Terms in Metrology, 2. edition, Geneva.
- ISO 10360, PART 2 (2001) Geometrical Product Specifications (GPS) - Acceptance and reverification tests for coordinate measuring machines (CMM).
- ISO 5725 (1986) Precision of test methods - Determination of repeatability and reproducibility for a standard test method by inter-laboratory tests.
- JACOBS, S. (2004) Battery Power for Remote Wireless Sensors. Sensor Magazine Online, March 2004, <http://www.sensormag.com/articles/0304/42/main.shtml>.
- JOHANSSON, J., GUSTAFSSON, M., DELSING, J. (2006) Ultra-low power transmit/receive ASIC for battery operated ultrasound measurement systems. Sensors and Actuators Vol. 125, pp. 317-328.
- KANG, S., TESAR, D. (2004) A Noble 6-DOF Measurement Tool With Indoor GPS For Metrology and Calibration of Modular Reconfigurable Robots. IEEE ICM International Conference on Mechatronics, Istanbul, Turkey.
- KARL, H., WILLIG, A. (2003) A short survey of wireless sensor networks. Technical Report of Technical University Berlin Telecommunication Networks Group, [www.tkn.tu-berlin.de/publications/papers/TechReport\\_03\\_018.pdf](http://www.tkn.tu-berlin.de/publications/papers/TechReport_03_018.pdf).
- KAŽYS, R., MAŽEIKĀ, L., ŠLITERIS, R., VOLEIŠIS A. (2007) Online Profiling of Nonplanar Objects by High-Resolution Air-Coupled Ultrasonic Distance Measurements. IEEE Transactions on Instrumentation and Measurement, Vol. 56, No. 5, pp. 1825-1830.



- KOUMPIIS, K., HANNA, L., ANDERSSON, M., JOHANSSON, M. (2005) Wireless Industrial Control and Monitoring beyond Cable Replacement. In Proceedings PROFIBUS International Conference, Coombe Abbey, Warwickshire, UK.
- LAMANCUSA, J., FIGUEROA, J.F. (1990) Ranging errors caused by angular misalignment between ultrasonic transducer pairs. *Journal of Acoustic Society of America*, Vol. 87, No. 3, pp. 1327-1335.
- LEVENE, H. (1960) *Contributions to Probability and Statistics*. Stanford University Press.
- LILIENTHAL, A.J., DUCKETT, T. (2004) Building Gas Concentration Gridmaps with a Mobile Robot, *Robotics and Autonomous Systems*, Vol. 48, No. 1, pp. 3-16.
- MAGORI, V., WALKER, H. (1987) Ultrasonic Presence Sensors with Wide Range and High Local Resolution. *IEEE Transactions on Ultrasonics, Ferroelectrics, and Frequency Control*, Vol. 34, No. 2, pp. 201-211.
- MAISANO, D., JAMSHIDI, J., FRANCESCHINI, F., MAROPOULOS, P., MASTROGIACOMO, L., MILEHAM, A., OWEN, G. (2007). A Review of Two Multistation Large Volume Measuring Instrument: MScMS AND iGPS. *Digital Enterprise Technology (DET) 2007*, Bath, UK, pp. 418-425.
- MAISANO, D., JAMSHIDI, J., FRANCESCHINI, F., MAROPOULOS, P., MASTROGIACOMO, L., MILEHAM, A., OWEN, G. (2008) Indoor GPS: system functionality and initial performance evaluation. Forthcoming in *International Journal of Manufacturing Research*, DOI: 10.1504/IJMR.2008.019214.
- MAHAJAN, A., FIGUEROA, F. (1999) An automatic self-installation and calibration method for a 3D position sensing system using ultrasonics. *Robotics and Autonomous Systems*, No. 28, pp. 281-294.
- MANTHEY, W., KROEMER, N., MAGORI, V. (1991) Ultrasonic transducers and transducer arrays for applications in air. *Measurement Science and Technology*, Vol. 3, No. 3, pp. 249-261.
- MARTIN, J.M., JIMÉNEZ, A.R., SECO, F., CALDERON, L., PONS, J.L., CERES, R. (2002) Estimating the 3D-position from time delay data of US-waves: experimental analysis and new processing algorithm. *Sensors and Actuators*, Vol. 101, Issue 3, pp. 311-321.
- METRIS (2007) [http://www.metris.com/large\\_volume\\_tracking\\_positioning](http://www.metris.com/large_volume_tracking_positioning).
- METRONOR (2007) <http://www.metronor.com>.
- MIT COMPUTER SCIENCE AND ARTIFICIAL INTELLIGENCE LAB (2004) Cricket v2 User Manual. <http://cricket.csail.mit.edu/v2man.html>.
- MONTGOMERY, D.C. (2008) *Design and Analysis of Experiments - 7th Edition*, Wiley, New York.
- MOORE, D., LEONARD, J., RUS, D., TELLER, S. S. (2004) Robust distributed network localization with noisy range measurements. *Proceedings of SenSys 2004*, Baltimore, MD, pp. 50-61.
- NAGPAL, R., SHROBE, H., AND BACHRACH, J. (2003) Organizing a Global Coordinate System from Local Information on an Ad Hoc Sensor Network. *Proceedings of the International Workshop on Information Processing in Sensor Networks (IPSN 2003)*, Palo Alto, CA.
- NEIL, S. (2005) *Disruptive Technologies: Sensor Networks*. *Managing Automation Online Magazine*, <http://www.managingautomation.com/maonline/magazine/read.aspx>

- NICULESCU, D., AND NATH, B. (2003) Ad hoc positioning system (APS) using AOA, In Proceedings of IEEE Annual Joint Conference IEEE Computer and Communications Societies (INFOCOM'03), pp. 1734-1743.
- OH, S., CHEN, P., MANZO, M., SASTRY S. (2006) Instrumenting Wireless Sensor Networks for Real-Time Surveillance in Proc. of the International. Conference on Robotics and Automation, Orlando, Florida.
- OVERMARS, M. H. (1997) Designing the Computational Geometry Algorithms Library CGAL, Proceedings of WACG '96, Lecture Notes in Computer Science, Springer-Verlag.
- PAN, M., TSAI, C., TSENG, Y. (2006) Emergency Guiding and Monitoring Applications in Indoor 3D Environments by Wireless Sensor Networks, Tech. Rep. [http://www.cs.berkeley.edu/~kamin/pubs/icra06\\_mttvideo.pdf](http://www.cs.berkeley.edu/~kamin/pubs/icra06_mttvideo.pdf).
- PATWARI, N., ASH, J., KYPEROUNTAS, S., HERO III, A., MOSES, R., CORREAL, N. (2005) Locating the Nodes – Cooperative localization in wireless sensor networks. IEEE Signal processing Magazine, Vol. 22, No. 4, pp. 54-69.
- PEPPERL+FUCHS (2005) Internal Report on Factory Automation. <http://www.pepperl-fuchs.com>.
- PRIYANTHA, N.B., BALAKRISHNAN, H., DEMAINE, H.D., TELLER, S. (2005) Mobile-Assisted Localization in Wireless Sensor Networks. Proceedings of the 24th Annual Joint Conference of the IEEE Communications Society on Computer Communications (INFOCOM 2005), Vol. 1, Miami, Florida, March 13–17, 2005, pp. 172-183.
- PHILLIPS, S.D., SAWYERA, D., BORCHARDTA, B., WARDA, D., BEUTELB, D.E. (2000) A novel artifact for testing large coordinate measuring machines. Journal of the International Societies for Precision Engineering and Nanotechnology, No. 25, pp 29-34.
- POZZI, F. (2002) Comparison of 3D Measurement Techniques in Cultural Heritage Application: User Point of View. Proceedings of the 1st International Symposium on 3D Data Processing Visualization and Transmission - IEEE Computer Society, 19-21 June, Padova, Italy, pp. 762-765.
- PRIYANTHA, N. B., CHAKRABORTY, A., BALAKRISHNAN, H. (2000) The Cricket Location-Support system, Proceedings of the 6th ACM MOBICOM, Boston, MA.
- PUTTOCK, M. J. (1978) Large-Scale Metrology. Ann. CIRP, Vol. 21, No. 1, pp. 351-356.
- ROMER, K., KASTEN, O., MATTERN, F. (2002) Middleware Challenges for Wireless Sensor Networks. Mobile Computing and Communications Review, Vol. 6, No. 2, pp. 59-61.
- ROOKS, B. (2004) A vision of the future at TEAM. Sensor Review, Vol. 24, No. 2, pp. 137-143.
- SAFIGIANNI, A. S., TSOMPANIDOU, C.G. (2005) Measurements of Electric and Magnetic Fields Due to the Operation of Indoor Power Distribution Substations, IEEE Transactions on Power Delivery, Vol. 20, No. 3.
- SANDWITH, S., PREDMORE, R. (2001) Real-time 5-Micron Uncertainty with Laser Tracking Interferometer Systems using Weighted Trilateration. Proceedings of 2001 Boeing Large Scale Metrology Seminar, St. Louis.
- SAVVIDES, A., HAN., C., STRIVASTAVA, M. B. (2001) Dynamic fine-grained localization in ad hoc networks of sensors. Proceedings of ACM/IEEE 7<sup>th</sup> Annual International Conference on Mobile Computing and Networking (MobiCom'01), pp. 166-179.

- SCHURGERS, C., SRIVASTAVA, M.B. (2001) Energy efficient routing in wireless sensor networks. Military Communications Conference (MILCOM): Communications for Network-Centric Operations, Vol. 1, pp. 357-361.
- SHNAYDER, V., HEMPSTEAD, M., CHEN, B., WERNER ALLEN, M., WELSH, M. (2004) Simulating the Power Consumption of Large Scale Sensor Network Applications. Proceedings of SenSys'04, Baltimore, Maryland, November 3–5, 2004.
- SIRBU, M., LEHR, W., GILLET, S. (2006) Evolving Wireless Access Technologies for Municipal Broadband. Submitted to Forthcoming in Government Information Quarterly.
- SOTTILE, F., SPIRITO, M. (2006) Enhanced Quadrilateral-based Localization for Wireless Ad-hoc Networks. In Proceedings of IFIP Fifth Annual Mediterranean Ad Hoc Networking Workshop (Med-Hoc-Net 2006), June 14-17, Lipari, Italy.
- TAYLOR, C., RAHIMI, A., BACHRACH, J. SHROBE, H. (2005) Simultaneous Localization, Calibration, and Tracking in an ad Hoc Sensor Network. Tech. Rep., Computer Science and Artificial Intelligence Laboratory of MIT, <https://dspace.mit.edu/handle/1721.1/30541>.
- TODA, M. (2002) Cylindrical PVDF Film Transmitters and Receivers for Air Ultrasound. IEEE transactions on ultrasonics, ferroelectrics, and frequency control, Vol. 49, No. 5, pp. 626-634.
- TODA, M., DAHL J. (2005) PVDF corrugated transducer for ultrasonic ranging sensor. Sensors and Actuators, Vol. 134, pp.427-435.
- TOH, C.K. (2004) Research challenges for deployable & usable ad hoc mobile wireless networks. Proc. Japan Ad Hoc Wireless Networks Symposium.
- TOH, C.K., MAHONEN, P., UUSITALO, M. (2005) Standardization Efforts & Future Research Issues for Wireless Sensors & Mobile Ad Hoc Networks. IEICE Trans. Commun., Vol. E88–B, No. 9, pp. 3500-3507.
- TONG, C.C., FIGUEROA, J.F., BARBIERI, E. (2001) A Method for Short or Long Range Time-of-Flight Measurements Using Phase-Detection With an Analog Circuit. IEEE Transactions on Instrumentations and Measurement, Vol. 50, No. 5, pp. 1324-1328.
- VALERY, N. (1999) A Survey of Innovation in Industry. The Economist, February 20, 1999, p. 7.
- VIM (2004) “International Vocabulary of Basic and General Terms in Metrology”, International Organization for Standardization, Geneva, Switzerland.
- WANG, L. AND XI, F. (2006) Challenges in design and manufacturing. International Journal of Computer Integrated Manufacturing, Vol. 19, No. 5, pp. 409-410.
- WARRIOR, J. (1997) Smart Sensor Networks of the Future. Sensor Magazine Online, March 1997, [http://www.sensormag.com/articles/0397/net\\_mar/main.shtml](http://www.sensormag.com/articles/0397/net_mar/main.shtml).
- WEISS, L. (2002) Developing Tangible Strategies. Design Management Journal, Vol. 13, No. 1, pp. 32-38.
- WELCH, G., BISHOP, G., VICCI, L., BRUMBACK, S., KELLER, K. (2001) High-Performance Wide-Area Optical Tracking The HiBall Tracking System. In Presence: Teleoperators And Virtual Environments, Vol. 10, No. 1, pp. 1-21.
- ZAKRZEWSKI, J. (2003) Error and Uncertainty Reduction – Challenge for a Measuring Systems Designer. Measurement Science Review, Vol. 3, Section 1, pp. 31-34.