

ABRS Series Stage

User's Manual

P/N: EDS120 (Revision 1.05.00)



Dedicated to the Science of Motion
Aerotech, Inc.
101 Zeta Drive,
Pittsburgh, PA, 15238
Phone: 412-963-7470
Fax: 412-963-7459
www.aerotech.com



Product Registration

Register online at: <http://www.aerotech.com/prodreg.cfm>

Technical Support

United States Headquarters:

Phone: (412) 967-6440

Fax: (412) 967-6870

Email: service@aerotech.com

United Kingdom:

Phone: +44 118 940 9400

Fax: +44 118 940 9401

Email: service@aerotech.co.uk

Germany:

Phone: +49 911 967 9370

Fax: +49 911 967 9370

Email: service@aerotechgmbh.de

Japan:

Phone: +81(0)47-489-1741 (Sales)

Phone: +81(0)47-489-1742 (Service)

Fax: +81(0)47-489-1743

Email: service@aerotechkk.com.jp

China:

Phone: +852-3793-3488

Email: saleschina@aerotech.com

Revision History

Revision 1.05.00	April 5, 2011
Revision 1.04.00	March 26, 2009
Revision 1.03.00	January 9, 2009
Revision 1.02.00	June 13, 2008
Revision 1.01.00	April 9, 2007
Revision 1.00.00	October 19, 2006

Table of Contents

Table of Contents.....	iii
List of Figures.....	v
List of Tables.....	vii
Chapter 1: Overview.....	1
1.1. Standard Features.....	1
1.1.1. Optional Features.....	1
1.1.2. Model Numbers.....	2
1.2. Dimensions.....	3
1.3. Safety Procedures and Warnings.....	7
1.4. EC Declaration of Incorporation.....	9
Chapter 2: Installation.....	11
2.1. Unpacking and Handling the Stage.....	11
2.2. Preparing the Mounting Surface.....	12
2.3. Securing the Stage to the Mounting Surface.....	13
2.4. Attaching the Payload to the Stage.....	15
2.5. Electrical Installation.....	16
2.6. Air Requirements.....	17
Chapter 3: Operating Specifications.....	19
3.1. Environmental Specifications.....	19
3.2. Basic Specifications.....	20
3.3. Load Capability.....	23
3.4. Limit Switch Wiring.....	23
3.5. Standard Motor Wiring.....	24
3.6. Vacuum Operation.....	26
Chapter 4: Maintenance.....	27
4.1. Service and Inspection Schedule.....	27
4.1.1. Field Service.....	27
4.2. Cleaning and Lubrication.....	27
4.2.1. Recommended Cleaning Solvents.....	27
Appendix A: Warranty and Field Service.....	29
Appendix B: Technical Changes.....	31
Index.....	33
Reader's Comments.....	35

List of Figures

Figure 1-1: Standard ABRS-250MP Rotary Stage..... 1
 Figure 1-2: ABRS-150 Dimensions..... 3
 Figure 1-3: ABRS-200 Dimensions..... 4
 Figure 1-4: ABRS-250 Dimensions..... 5
 Figure 1-5: ABRS-300 Dimensions..... 6
 Figure 2-1: Results of Flat Versus Non-Flat Mounting..... 12
 Figure 2-2: Top View of an ABRS-250MP Stage Showing Mounting Holes..... 13
 Figure 2-3: Side View of an ABRS-250MP Stage Showing Tapped Fixturing Holes..... 14

List of Tables

Table 1-1: Model Numbering System	2
Table 3-1: Environmental Specifications.....	19
Table 3-2: ABRS Series Specifications.....	20
Table 3-3: ABRS Series Resolution Information.....	21
Table 3-4: ABRS Series Maximum Encoder Frequency.....	21
Table 3-5: ABRS Motor Specifications.....	22
Table 3-6: ABRS Series Load Capability.....	23
Table 3-7: Standard Wiring Connector for ABRS-150MP Stage.....	24
Table 3-8: Standard Wiring Connectors for ABRS-200MP, -250MP, and -300MP Stages.....	25
Table 3-9: Motor Wiring Pinout Descriptions.....	26
Table B-1: Current Changes (1.05.00).....	31
Table B-2: Archived Changes.....	32

Chapter 1: Overview

This chapter introduces standard and optional features of the ABRS stages, explains the model numbering system, and gives general safety precautions.

1.1. Standard Features

All ABRS stages incorporate completely non-contact air bearing surfaces, direct drive brushless motors and feedback devices to provide a completely maintenance free stage. There is no mechanical contact to become worn or require lubrication, making these stages ideal for clean room and medical applications.

The ABRS is designed to give the lowest possible height to minimize error and maximize performance in space-constrained areas. The direct drive design is optimum for continuous production environments due to the maintenance free design of the motor. The direct drive and slotless motor design combine to create outstanding velocity control. This is especially useful in scanning applications where a torque ripple cannot be tolerated.

1.1.1. Optional Features

All ABRS stages incorporate a center aperture, ranging in size from 8 mm to 75 mm diameter. The tabletops can be built with either metric or custom hole patterns depending on requirements.

Additionally, the encoder can be configured for either square-wave or amplified sine output.

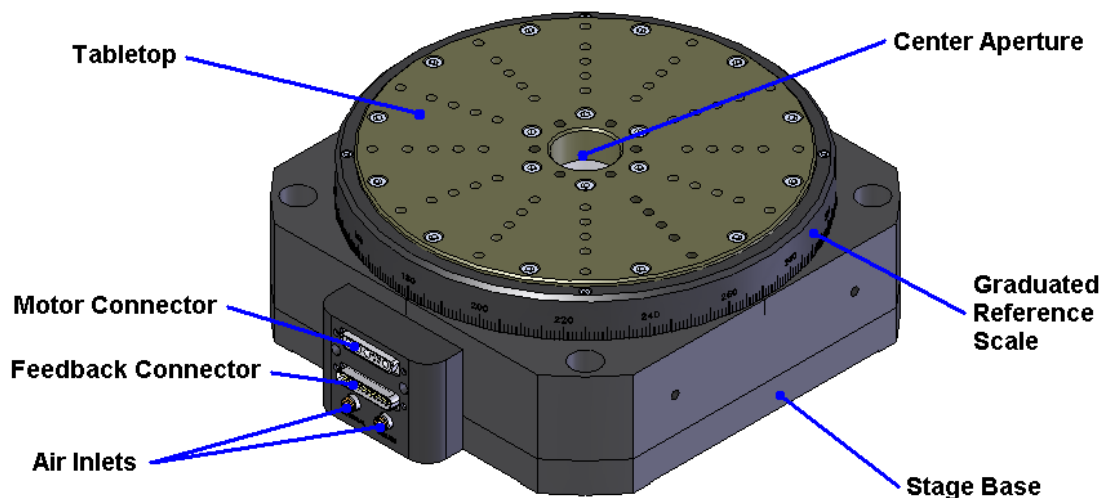

Figure 1-1: Standard ABRS-250MP Rotary Stage

1.1.2. Model Numbers

The stage model number indicates the optional features on a particular stage. To determine the options on your stage, refer to Table 1-1 for an explanation of the numbering system.

Example: ABRS-200MP-M-AS

This designates an ABRS-200MP stage with direct drive motor, metric dimension mounting pattern, and 1vpp sine wave encoder.

Aerotech continually improves its product offerings, and listed options may be superseded at any time. Refer to the most recent edition of the Aerotech Motion Control Product Guide for the most current product information at www.aerotech.com.

Table 1-1: Model Numbering System

ABRS Series Direct Drive Rotary Stage	
ABRS-150MP	150 mm wide air-bearing rotary stage with 0.82 N-m peak torque output
ABRS-200MP	200 mm wide air-bearing rotary stage with 2.12 N-m peak torque output
ABRS-250MP	250 mm wide air-bearing rotary stage with 9.42 N-m peak torque output
ABRS-300MP	300 mm wide air-bearing rotary stage with 23.98 N-m peak torque output
Mounting Pattern	
-M	Metric dimension mounting pattern and holes
Position Transducer	
-AS	Standard feedback device, sine wave output; 3600 cycles per rev on ABRS-150MP; 8192 cycles per rev on ABRS-200MP; 11,840 cycles per rev on ABRS-250MP; 18,000 cycles per rev on ABRS-300MP
-X50	Square wave digital output; 180,000 cycles per rev on ABRS-150MP; 409,600 cycles per rev on ABRS-200MP; 592,000 cycles per rev on ABRS-250MP; 900,000 cycles per rev on ABRS-300MP
Note: Digital output encoder signals are synthesized with a 16 MHz clock. Care must be taken to ensure that the encoder sample rate on the controller is at least 16 MHz or higher. Slower clock rates are available on request.	

1.2. Dimensions

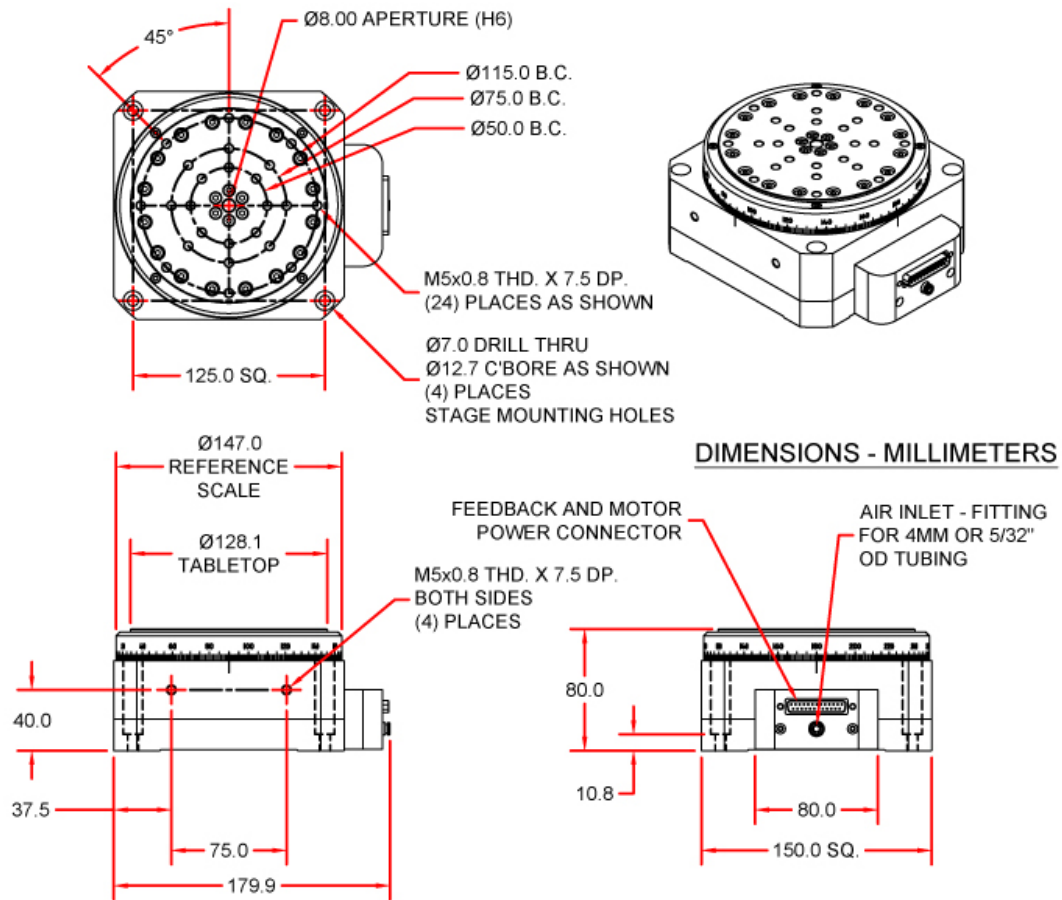

Figure 1-2: ABRS-150 Dimensions

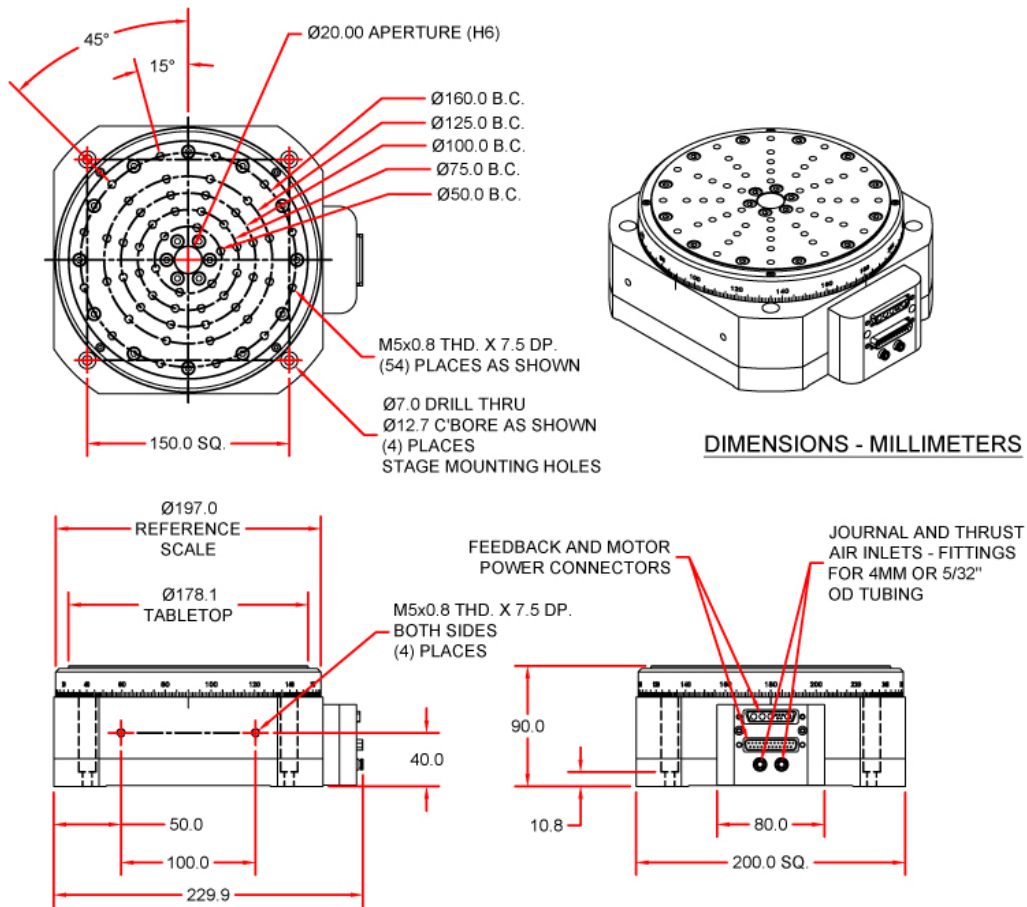

Figure 1-3: ABRS-200 Dimensions

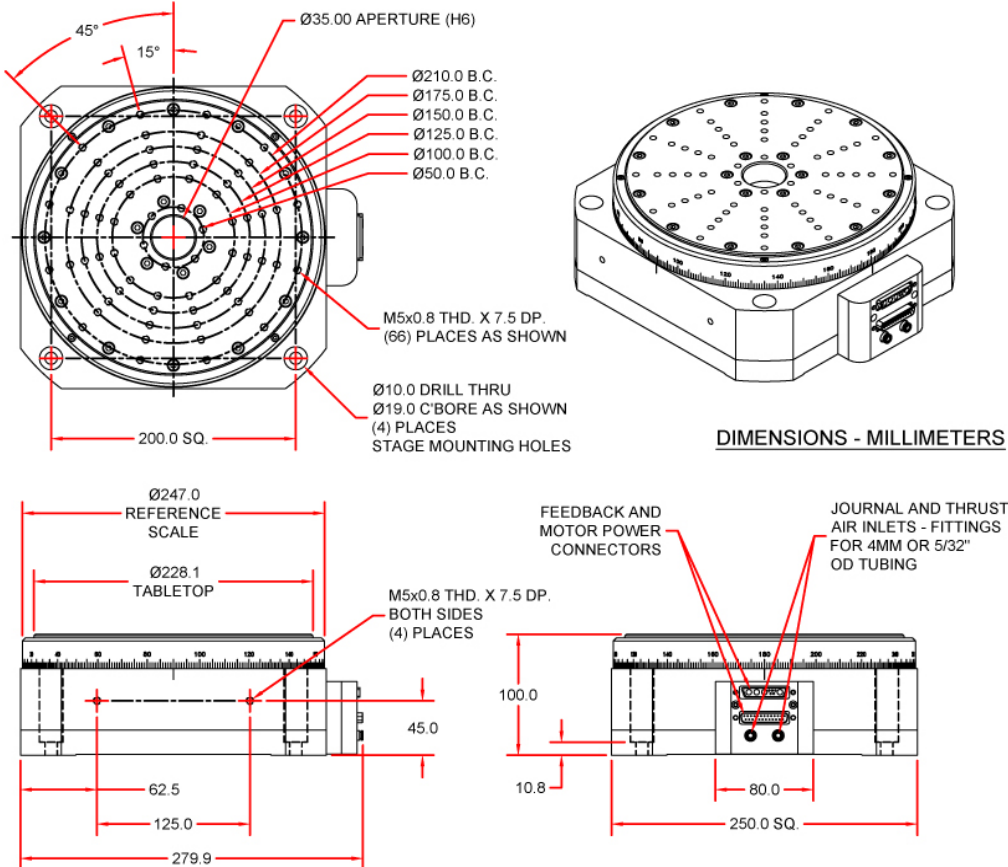

Figure 1-4: ABRS-250 Dimensions

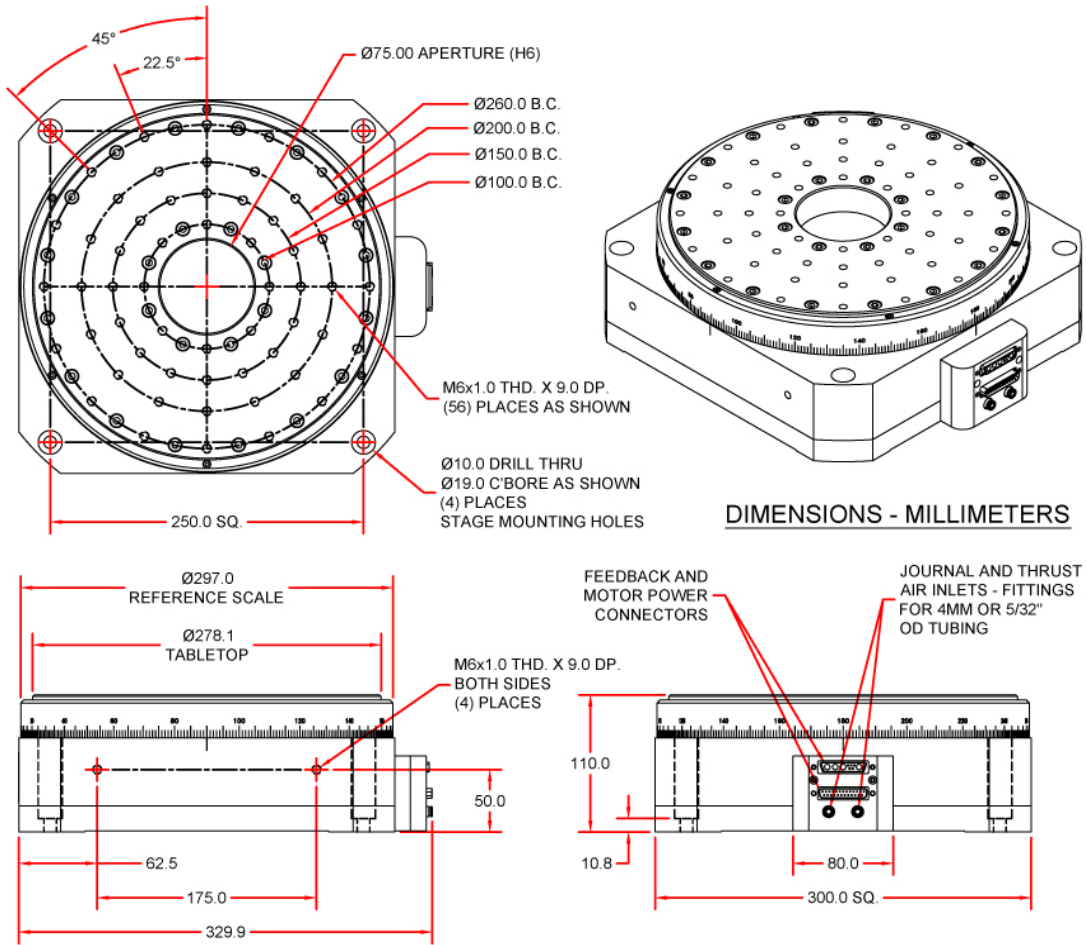

Figure 1-5: ABRS-300 Dimensions

1.3. Safety Procedures and Warnings

The following statements apply throughout this manual. Failure to observe these precautions could result in serious injury to those performing the procedures and damage to the equipment.

This manual and any additional instructions included with the stage should be retained for the lifetime of the stage.



DANGER

To minimize the possibility of electrical shock and bodily injury or death, disconnect all electrical power prior to making any electrical connections.



DANGER

To minimize the possibility of electrical shock and bodily injury or death when any electrical circuit is in use, ensure that no person comes in contact with the circuitry when the stage is connected to a power source.



DANGER

To minimize the possibility of bodily injury or death, disconnect all electrical power prior to making any mechanical adjustments.



DANGER

Moving parts of the stage can cause crushing or shearing injuries. All personnel must remain clear of any moving parts.



WARNING

Improper use of the stage can cause damage, shock, injury, or death. Read and understand this manual before operating the stage.



WARNING

If the stage is used in a manner not specified by the manufacturer, the protection provided by the stage can be impaired.



WARNING

Stage cables can pose a tripping hazard. Securely mount and position all stage cables to avoid potential hazards.



WARNING

Do not expose the stage to environments or conditions outside the specified range of operating environments. Operation in conditions other than those specified can cause damage to the equipment.



WARNING

The stage must be mounted securely. Improper mounting can result in injury and damage to the equipment.



WARNING

Use care when moving the stage. Manually lifting or transporting stages can result in injury.



WARNING

Only trained personnel should operate, inspect, and maintain the stage.



WARNING

This stage is intended for light industrial manufacturing or laboratory use. Use of the stage for unintended applications can result in injury and damage to the equipment.



WARNING

Before using this stage, perform an operator risk assessment to determine the needed safety requirements.

1.4. EC Declaration of Incorporation

Manufacturer: Aerotech, Inc.
101 Zeta Drive
Pittsburgh, PA 15238
USA



herewith declares that the product:

Aerotech, Inc. ABRS Stage

is intended to be incorporated into machinery to constitute machinery covered by the Directive 2006/42/EC as amended;

does therefore not in every respect comply with the provisions of this directive;

and that the following harmonized European standards have been applied:

EN ISO 12100-1,-2:2003+A1:2009

Safety of machinery - Basic concepts, general principles for design

ISO 14121-1:2007

Safety of machinery - Risk assessment - Part 1: Principles

EN 60204-1:2005

Safety of machinery - Electrical equipment of machines - Part 1: General requirements

and further more declares that

it is not allowed to put the equipment into service until the machinery into which it is to be incorporated or of which it is to be a component has been found and declared to be in conformity with the provisions of the Directive 2006/42/EC and with national implementing legislation, i.e. as a whole, including the equipment referred to in this Declaration.

Authorized Representative: Manfred Besold
Address: AEROTECH GmbH
Süd-West-Park 90
D-90449 Nürnberg

Name:

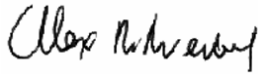
Alex Weibel / 
Engineer Verifying Compliance

Position:

Location: Pittsburgh, PA

Date: April 5, 2011

Chapter 2: Installation

This chapter describes the installation procedure for the ABRS stage, including handling the stage properly, preparing the mounting surface to accept the stage, securing the stage to the mounting surface, attaching the payload, and making the electrical connections.



Installation must follow the instructions in this chapter. Failure to follow these instructions could result in injury and damage to the equipment.

2.1. Unpacking and Handling the Stage

Carefully remove the stage from the protective shipping container. Blow the stage off with compressed nitrogen or clean, dry air. Before operating the stage, it is important to let the stage stabilize at room temperature for at least 12 hours. Set the stage on a smooth, flat, and clean surface.

Each stage has a label listing the system part number and serial number. These numbers contain information necessary for maintaining or updating system hardware and software. Locate this label and record the information for later reference. If any damage has occurred during shipping, report it immediately.



Improper stage handling could adversely affect the stage's performance. Therefore, use care when moving the stage. Manually lifting or transporting stages can result in injury.



Lift the stage only by the base. Do not use the tabletop or wiring connections to support the stage.



Do not attempt to rotate the stage table until the air supply, detailed in Section 2.6, has been installed. Moving the stage table without air supplied can cause permanent damage to the stage.

2.2. Preparing the Mounting Surface

The mounting surface should be flat and have adequate stiffness in order to achieve the maximum performance from the ABRS. When an ABRS series stage is mounted to a non-flat surface, the stage can be distorted as the mounting screws are tightened. This distortion will decrease the overall accuracy of the stage. *To maintain accuracy, the mounting surface should be flat within 2 μ m TIR.* Adjustments to the mounting surface must be done before the stage is secured. The effects of flatness on mounting are illustrated in Figure 2-1.

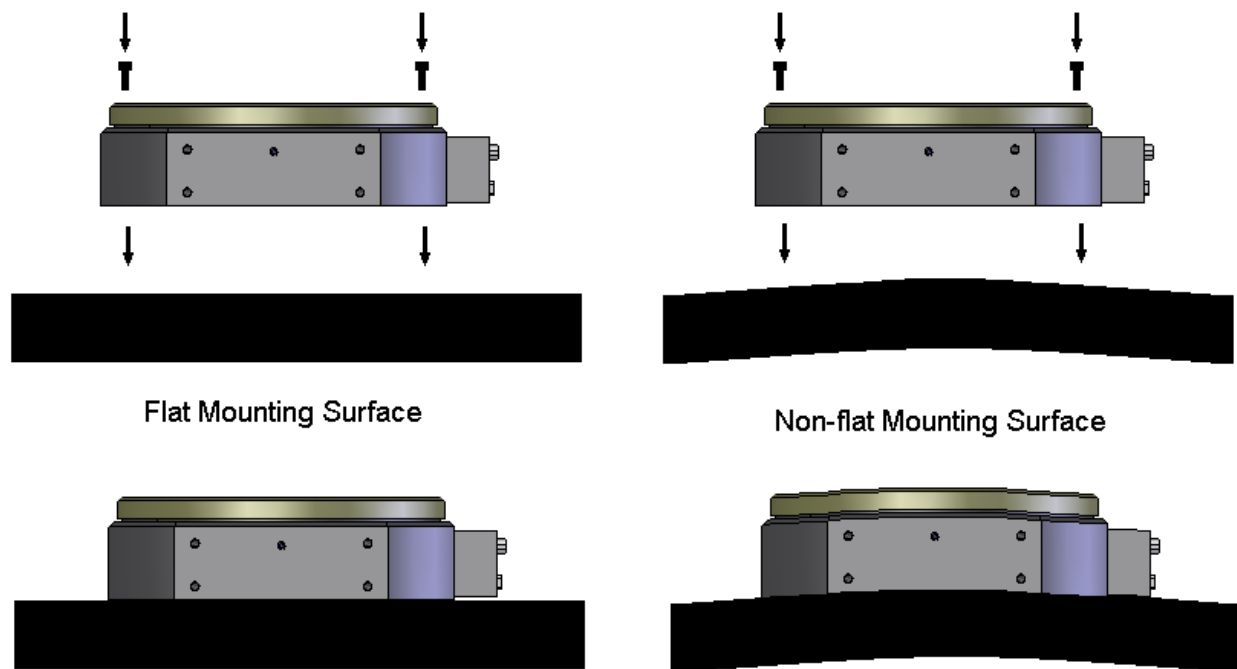

Figure 2-1: Results of Flat Versus Non-Flat Mounting

NOTE: The stage base is precision machined and verified for flatness prior to stage assembly at the factory. If machining is required to achieve the desired flatness, it should be performed on the mounting surface rather than the stage base. Shimming should be avoided if possible. If shimming is required, it should be minimized to improve the rigidity of the system.

It is important that the stage is mounted to a horizontal surface. Vertical- or side-mounted orientations are generally not recommended and could affect performance. Please consult the factory before attempting to mount the stage in these non-recommended orientations.

2.3. Securing the Stage to the Mounting Surface

ABRS series stages have counterbored mounting holes available to secure the stage to a mounting surface.

Figure 2-2 shows these mounting holes in the base of the stage. These counterbored holes are designed for either 6 mm or 8 mm socket head cap screws depending on the particular stage model. Additionally, the sides of the stage are equipped with several M5x0.8 or M6x1.0 tapped holes (depending on stage model) with reinforced threaded inserts Figure 2-3. These tapped holes are to be used for optional fixture mounting only, depending on customer requirements, and are not recommended to be used for mounting the stage.



The stage must be mounted securely. Improper mounting can result in injury and damage to the equipment.

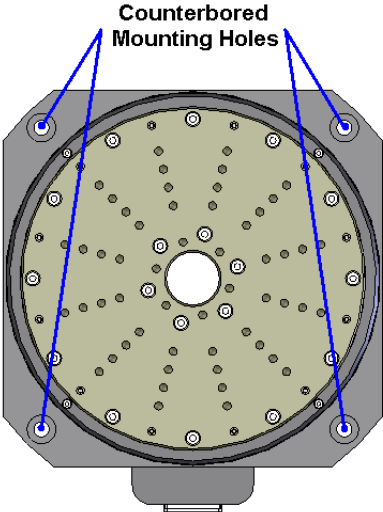

Figure 2-2: Top View of an ABRS-250MP Stage Showing Mounting Holes

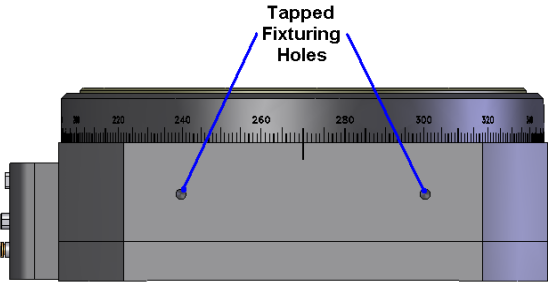

Figure 2-3: Side View of an ABRS-250MP Stage Showing Tapped Fixturing Holes

2.4. Attaching the Payload to the Stage

To prevent damage to the stage or parts, test the operation of the stage before any payload is mounted to the stage tabletop. Proceed with the electrical installation and test the motion control system in accordance with the system documentation. Document all results for future reference. For information on electrical connections, refer to the Electrical Installation section later in this chapter, the documentation of the motion control system delivered with the stage, and the wiring drawings in Chapter 3: Operating Specifications.

The payload must be flat, rigid and comparable to the stage in quality. *For valid accuracy, the mounting interface should be flat within $2\mu\text{m}$ TIR.* Additionally, the payload must be reasonably balanced in order to maintain stage accuracy. Please consult the factory to determine if the payload may potentially result in any deterioration of stage performance.

There are several mounting holes provided on the stage tabletop to mount payloads. The payload mounting holes are M5x0.8 or M6x1.0 (depending on the particular stage model) and have reinforced threads to allow frequent removal and installation of mounting screws.

2.5. Electrical Installation

Aerotech motion control systems are adjusted at the factory for optimum performance. When the ABRS series stage is part of a complete Aerotech motion control system, setup involves connecting a stage and motor combination to the appropriate drive chassis with the cables provided. Connect the provided cables to the feedback and motor connectors on the stage body. Labels on the drive indicate the appropriate connections. Refer to your drive manuals and documentation for additional installation and operation information. In some cases, if the system is uniquely configured, a drawing showing system interconnects is supplied.

See Section 3.5. for standard motor wiring and connector pin outputs.



WARNING

Never connect or disconnect any electrical component or connecting cable while power is applied, or serious damage may result.



WARNING

The stage's protective ground is located on pin 10 and 22 of the feedback connector (ABRS-150MP) or pin A4 of the motor connector (ABRS-200MP, -250MP, and -300MP). If you are using cables other than those provided by Aerotech, you must connect these pins to a ground connection.

2.6. Air Requirements

The air supply to the air bearing is important for the operation of the system. If compressed air is used, it must be filtered to 0.25 microns, dry to 0°F dewpoint, and oil free. If nitrogen is used, it must be 99.99% pure and filtered to 0.25 microns. The filtration requirement is to prevent particles from clogging the air bearing orifices, which can be as small as a few thousandths of an inch in diameter.

Air pressure of 80 psi, +0/−10 psi, is necessary for use. Air should be supplied via 4mm OD or 5/32" OD polyurethane air hose(s). It is recommended that a pressure switch be installed to remove power from the air bearing if pressure drops below 40 psi because the bearing surfaces could be damaged. An air flow rate of less than 2 SCFM should be observed (single axis.)

Certain stage models include separate porting for the thrust and journal air bearings. In some applications it may be desirable to "lock-down" the stage by removing air pressure to the thrust bearing while maintaining air pressure to the journal bearing. Power must be removed from the stage while it is "locked-down" to avoid damage to the thrust bearing surfaces. It is highly recommended to consult the factory for detailed assistance if this "lock-down" feature is to be utilized.

Chapter 3: Operating Specifications

This chapter contains general technical information about ABRS series stages. Included are basic product specifications, resolution information, and motor wiring diagrams.

3.1. Environmental Specifications

The environmental specifications for the ABRS are listed in the following table.

Table 3-1: Environmental Specifications

Ambient Temperature	Operating: 16° to 25° C (61° to 77° F) The optimal operating temperature is 20° C \pm 2° C (68° F \pm 4° F). If at any time the operating temperature deviates from 20° C degradation in performance could occur. Contact Aerotech for information regarding your specific application and environment.
	Storage: 0° to 40° C (32° to 104° F) in original shipping packaging
Humidity	Operating: 40 percent to 60 percent RH The optimal operating humidity is 50 percent RH.
	Storage: 30 percent to 60 percent RH, non-condensing in original packaging
Altitude	Operating: 0 to 2,000 m (0 to 6,562 ft) above sea level Contact Aerotech if your specific application involves use above 2,000 m or below sea level.
Vibration	Use the system in a low vibration environment. Excessive floor or acoustical vibration can affect stage and system performance. Contact Aerotech for information regarding your specific application.
Dust Exposure	The ABRS stages are not suited for dusty or wet environments. This equates to an ingress protection rating of IP00.
Use	Indoor use only



Do not expose the stage to environments or conditions outside the specified range of operating environments. Operation in conditions other than those specified can cause damage to the equipment.

3.2. Basic Specifications

The ABRS series rotary stage specifications are shown in Table 3-2. Encoder resolution information is given in Table 3-3 and speed limitations are given in Table 3-4. Motor specifications are given in Table 3-5.

Table 3-2: ABRS Series Specifications

ABRS Series	ABRS-150MP	ABRS-200MP	ABRS-250MP	ABRS-300MP
Width	150 mm	200 mm	250 mm	300mm
Tabletop Diameter	128.1 mm	178.1 mm	228.1 mm	278.1 mm
Height	80 mm	90 mm	100 mm	110 mm
Aperture	8 mm	20 mm	35 mm	75 mm
Total Travel	±360° Continuous			
Resolution ⁽¹⁾	0.873 μrad (0.18 arc sec)	0.383 μrad (0.079 arc sec)	0.267 μrad (0.055 arc sec)	0.174 μrad (0.036 arc sec)
Max Speed ⁽²⁾	300 rpm	300 rpm	500 rpm	500 rpm
Accuracy (calibrated)	±3 arc sec	±2 arc sec		
Repeatability	<2 arc sec	<1 arc sec		
Axial Error (synchronous)	<175 nm	<100 nm		
Radial Error (synchronous)	<450 nm	<250 nm		
Tilt Error (synchronous)	<2.0 arc sec	<0.7 arc sec	<0.5 arc sec	<0.5 arc sec
Axial Error (asynchronous)	<20 nm			
Radial Error (asynchronous)	<20 nm			
Tilt Error (asynchronous)	<0.08 arc sec	<0.06 arc sec	<0.04 arc sec	<0.04 arc sec
Inertia (unloaded)	3850 kg-mm ²	13,800 kg-mm ²	39,100 kg-mm ²	102,000 kg-mm ²
Total Mass	4.8 kg	9.1 kg	15.6 kg	24.5 kg
Material	Aluminum			
Finish	Hard Coating (62 Rockwell Hardness)			
1. Maximum resolution presumes A3200 controller using MXH500 multiplication, and accounts for controller quadrature.				
2. Maximum speed based on stage capability. Maximum application velocity may be limited by system data rate and system resolution.				

Table 3-3: ABRS Series Resolution Information

	ABRS-150MP	ABRS-200MP	ABRS-250MP	ABRS-300MP
Lines	3600	8192	11,840	18,000
X50	1.8 arc sec	0.79 arc sec	0.55 arc sec	0.36 arc sec
AS (sine)*	360 arc sec	158 arc sec	109 arc sec	72 arc sec
* Fundamental resolution of sine wave output from encoder. Up to x500 available with Aerotech controller.				

Table 3-4: ABRS Series Maximum Encoder Frequency

Resolution-Speed	ABRS-150MP	ABRS-200MP	ABRS-250MP	ABRS-300MP
AS	300 rpm	300 rpm	500 rpm	500 rpm
X50	300 rpm	234 rpm	162 rpm	107 rpm

NOTE: The encoders used on all ABRS-series stages come standard with a 16 MHz clock rate. Aerotech can provide slower or faster clock rates to match the controller being used. Consult the factory for more information.

Table 3-5: ABRS Motor Specifications

Model		S-50-39	S-76-35	S-130-39	S-180-44
Winding Designation		-A	-A	-A	-A
Performance Specifications (1,5)					
Stall Torque, Continuous (2)	N-m	0.20	0.53	2.36	5.99
	oz-in	29.0	75.0	20.9	53.1
Peak Torque (3)	N-m	0.82	2.12	9.42	23.98
	oz-in	116.0	300.0	83.4	212.2
Rated Speed	rpm	4,000	3,000	2,000	500
Rated Power Output, Continuous	watts	85.7	166.3	493.4	313.8
Electrical Specifications (5)					
BEMF Constant (line to line, max)	Volts pk / krpm	10.3	32.1	75.1	268.7
Continuous Current, Stall (2)	Amp pk	2.4	2.0	3.8	2.7
	Amp rms	1.7	1.4	2.7	1.9
Peak Current, Stall (3)	Amp pk	9.6	8.0	15.2	10.8
	Amp rms	6.8	5.7	10.7	7.6
Torque Constant (4,9)	N-m / Amp pk	0.09	0.26	0.62	2.22
	oz-in / Amp pk	12.1	37.5	5.5	19.7
	N-m / Amp rms	0.12	0.37	0.88	3.14
	oz-in / Amp rms	17.1	53.0	7.8	27.8
Motor Constant (2,4)	N-m / \sqrt{W}	0.034	0.083	0.265	0.628
	oz-in / \sqrt{W}	4.76	11.72	2.35	5.56
Resistance, 25 °C (line to line)	ohms	6.6	10.5	5.6	12.8
Inductance (line to line)	mH	1.50	1.40	1.70	3.40
Maximum Bus Voltage	VDC	340	340	340	340
Thermal Resistance	°C / W	2.02	1.83	0.95	0.82
Number of Poles	P	8	14	18	18
(1) Performance is dependent upon heat sink configuration, system cooling conditions, and ambient temperature (2) Values shown @ 75 °C rise above a 25 °C ambient temperature, with housed motor mounted to a 330 mm x 330 mm x 13 mm aluminum heat sink (3) Peak torque assumes correct rms current, consult Aerotech (4) Torque Constant and Motor Constant specified at stall (5) All performance and electrical specifications +/- 10% (6) Losses due to bearings and aerodynamics considered negligible (7) Maximum winding temperature is 100 °C, Thermistor trips at 100 °C (8) Ambient operating temperature range: 0 °C - 25 °C, consult Aerotech for performance in elevated ambient temperatures (9) All Aerotech amplifiers are rated Apk; use torque constant in N-m/Apk when sizing					

3.3. Load Capability

The ABRS rotary stage loading specifications are shown in Table 3-6.

Table 3-6: ABRS Series Load Capability

ABRS Series	ABRS-150MP	ABRS-200MP	ABRS-250MP	ABRS-300MP
Max Load – Axial*	8 kg	31 kg	66 kg	97 kg
Max Load – Radial*	4 kg	15 kg	36 kg	51 kg
Max Load – Tilt*	3 N-m	10 N-m	28 N-m	45 N-m

* Maximum loads are mutually exclusive.

3.4. Limit Switch Wiring

Standard ABRS stages do not include end-of-travel limits. Consult the factory for a custom solution.

3.5. Standard Motor Wiring

Stages come from the factory completely wired and assembled. For reference, connector pin outputs (pin-outs) and general wiring information are given in the following figures. Pinouts are defined in Table 3-9.

NOTE: Refer to the other documentation accompanying your Aerotech equipment. Call your Aerotech representative if there are any questions on system configuration.

NOTE: If you are using your own cables to connect the stage, ensure that the motor and ground wires can handle current higher than the continuous current listed in Section 3.2. The voltage rating of the wire insulation must be greater than the maximum bus voltage listed in Section 3.2.

Table 3-7: Standard Wiring Connector for ABRS-150MP Stage

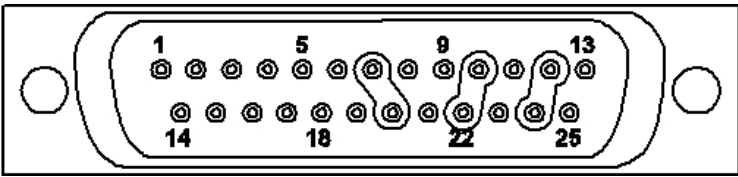

Pin	Description	Pin	Description
1	KEY	14	COS
2	COS-N	15	SIN
3	SIN-N	16	MKR
4	MKR-N	17	ENC +5V
5	ENC COM	18	LMT +5V
6	LMT COM	19	
7		20	
8	HALL A	21	HALL B
9	HALL C	22	MTR SHLD
10	FRM GND	23	MTR ØA
11	MTR ØA	24	MTR ØB
12	MTR ØB	25	MTR ØC
13	MTR ØC		

Table 3-8: Standard Wiring Connectors for ABRS-200MP, -250MP, and -300MP Stages

			
Pin	Description	Pin	Description
A1	MTR ØA	3	RESERVED
A2	MTR ØB	4	RESERVED
A3	MTR ØC	5	RESERVED
1	MTR SHLD	A4	FRM GND
2	RESERVED		
			
Pin	Description	Pin	Description
1	SIG SHLD	14	COS
2	TH+	15	COS-N
3	ENC +5V	16	LMT +5V
4		17	SIN
5	HALL B	18	SIN-N
6	MKR-N	19	
7	MKR	20	LMT COM
8	RESERVED	21	ENC COM
9		22	
10	HALL A	23	
11	HALL C	24	
12		25	
13			

Table 3-9: Motor Wiring Pinout Descriptions

Pin Output	Description
COS	Cosine. Incremental encoder output; either TTL line driven or amplified sine wave type signal.
COS-N	Incremental encoder output. Complement of cos.
ENC COM	+ 5 V return for optical encoders (ground).
ENC +5V	+5 V supply input for optical encoders. Typical requirement is 250 mA.
HALL A	Hall Effect A. Brushless motor commutation track output. TTL line driven signal with rotary motor.
HALL B	Hall Effect B. Brushless motor commutation track output. TTL line driven signal with rotary motor.
HALL C	Hall Effect C. Brushless motor commutation track output. TTL line driven signal with rotary motor.
LMT +5v	+ 5 V supply input for optical limit switch boards. Typical requirement is 50 mA.
LMT COM	Common ground for limit switch
MKR	Marker. Incremental encoder output pulse given once per revolution. Typically used for home reference cycle.
MKR-N	Incremental encoder output; either the compliment of Marker with a line driven, TTL type encoder or 2.5 V DC bias level with amplified sine wave type encoder.
SIN	Sine. Incremental encoder output; either TTL line driven or amplified sign wave type signal.
SIN-N	Incremental encoder output. Complement of sin.
TH+	Positive lead for motor thermistor (to motion controller)
TH-	Negative lead for motor thermistor (tied to ground via feedback connector).
MTR ØA	Motor Phase A.
MTR ØB	Motor Phase B.
MTR ØC	Motor Phase C.
FRM GND	Ground to stage base
SIG SHLD	Shield for feedback connector
MTR SHLD	Shield for motor wiring connector

3.6. Vacuum Operation

The ABRS is an air-bearing stage and is not compatible with operation in a vacuum environment. Please contact the factory for alternate solutions.

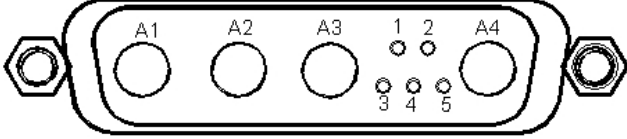
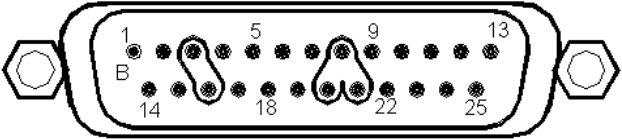
Chapter 4: Maintenance

The ABRS series stages are designed to be maintenance-free positioning systems. Due to the non-contact air bearing design, there are no friction surfaces or dynamic seals to wear or require lubrication. The ABRS stages do not require any maintenance other than periodic cleaning. Included in this chapter are recommended cleaning solvents.

NOTE: The stage must be kept free of foreign matter and moisture; otherwise, the performance and life expectancy of the stage will be reduced.



To minimize the possibility of bodily injury, confirm that all electrical power is disconnected prior to making any mechanical adjustments.

4.1. Service and Inspection Schedule

It is recommended that the ABRS stage be inspected once per month until a trend develops for the specific application and environment.

4.1.1. Field Service

In general, repair and/or replacement of damaged or malfunctioning components of the ABRS stage by Aerotech field service personnel is not possible. Stage repair typically requires that the unit be returned to the factory. Please contact Aerotech Technical Support for more information.

4.2. Cleaning and Lubrication

There are no elements of the ABRS series stages that require lubrication. Periodic cleaning to remove dust is recommended.

4.2.1. Recommended Cleaning Solvents

Before using a cleaning solvent on any part of the stage, it is recommended that compressed nitrogen or clean, dry air be used to blow away small particles and dust. Any metal surface of the stage may be cleaned with isopropyl alcohol on a lint-free cloth. Avoid getting excess cleaning solvent on the surfaces, as it could damage the delicate electronics inside.



To minimize the possibility of bodily injury, confirm that all electrical power is disconnected prior to making any mechanical adjustments.

Appendix A: Warranty and Field Service

Aerotech, Inc. warrants its products to be free from defects caused by faulty materials or poor workmanship for a minimum period of one year from date of shipment from Aerotech. Aerotech's liability is limited to replacing, repairing or issuing credit, at its option, for any products that are returned by the original purchaser during the warranty period. Aerotech makes no warranty that its products are fit for the use or purpose to which they may be put by the buyer, where or not such use or purpose has been disclosed to Aerotech in specifications or drawings previously or subsequently provided, or whether or not Aerotech's products are specifically designed and/or manufactured for buyer's use or purpose. Aerotech's liability or any claim for loss or damage arising out of the sale, resale or use of any of its products shall in no event exceed the selling price of the unit.

Aerotech, Inc. warrants its laser products to the original purchaser for a minimum period of one year from date of shipment. This warranty covers defects in workmanship and material and is voided for all laser power supplies, plasma tubes and laser systems subject to electrical or physical abuse, tampering (such as opening the housing or removal of the serial tag) or improper operation as determined by Aerotech. This warranty is also voided for failure to comply with Aerotech's return procedures.

Laser Products

Claims for shipment damage (evident or concealed) must be filed with the carrier by the buyer. Aerotech must be notified within (30) days of shipment of incorrect materials. No product may be returned, whether in warranty or out of warranty, without first obtaining approval from Aerotech. No credit will be given nor repairs made for products returned without such approval. Any returned product(s) must be accompanied by a return authorization number. The return authorization number may be obtained by calling an Aerotech service center. Products must be returned, prepaid, to an Aerotech service center (no C.O.D. or Collect Freight accepted). The status of any product returned later than (30) days after the issuance of a return authorization number will be subject to review.

Return Procedure

After Aerotech's examination, warranty or out-of-warranty status will be determined. If upon Aerotech's examination a warranted defect exists, then the product(s) will be repaired at no charge and shipped, prepaid, back to the buyer. If the buyer desires an airfreight return, the product(s) will be shipped collect. Warranty repairs do not extend the original warranty period.

Returned Product Warranty Determination

After Aerotech's examination, the buyer shall be notified of the repair cost. At such time, the buyer must issue a valid purchase order to cover the cost of the repair and freight, or authorize the product(s) to be shipped back as is, at the buyer's expense. Failure to obtain a purchase order number or approval within (30) days of notification will result in the product(s) being returned as is, at the buyer's expense. Repair work is warranted for (90) days from date of shipment. Replacement components are warranted for one year from date of shipment.

Returned Product Non-warranty Determination

At times, the buyer may desire to expedite a repair. Regardless of warranty or out-of-warranty status, the buyer must issue a valid purchase order to cover the added rush service cost. Rush service is subject to Aerotech's approval.

Rush Service

On-site Warranty Repair If an Aerotech product cannot be made functional by telephone assistance or by sending and having the customer install replacement parts, and cannot be returned to the Aerotech service center for repair, and if Aerotech determines the problem could be warranty-related, then the following policy applies:

Aerotech will provide an on-site field service representative in a reasonable amount of time, provided that the customer issues a valid purchase order to Aerotech covering all transportation and subsistence costs. For warranty field repairs, the customer will not be charged for the cost of labor and material. If service is rendered at times other than normal work periods, then special service rates apply.

If during the on-site repair it is determined the problem is not warranty related, then the terms and conditions stated in the following "On-Site Non-Warranty Repair" section apply.

On-site Non-warranty Repair If any Aerotech product cannot be made functional by telephone assistance or purchased replacement parts, and cannot be returned to the Aerotech service center for repair, then the following field service policy applies:

Aerotech will provide an on-site field service representative in a reasonable amount of time, provided that the customer issues a valid purchase order to Aerotech covering all transportation and subsistence costs and the prevailing labor cost, including travel time, necessary to complete the repair.

Company Address Aerotech, Inc.
101 Zeta Drive
Pittsburgh, PA
15238-2897

Phone: (412) 963-7470

Fax: (412) 963-7459

Appendix B: Technical Changes

Table B-1: Current Changes (1.05.00)

Section(s) Affected	General Information
Section 1.4.	Section added
Section 3.1.	Section added
Chapter 2: Installation, Section 2.1. , Section 2.3. , Section 2.5. , and Sec- tion 1.3.	Added safety information and warnings
Section 1.1.2.	Corrected peak output torque values
Section 3.5.	Added note about current requirements of motor and ground wires, changed pin 8 to reserved
Section 3.2.	Added motor specifications

Table B-2: Archived Changes

Revision	Section(s) Affected	General Information
1.04.00	Table 3-2	ABRS-150MP specifications updated
1.03.00	Section 1.2.	Dimensions section added
1.02.00	Section 2.6.	Air Requirements section added
1.01.00	Table 3-6	ABRS Series Load Capability table updated
1.00.00	--	New Manual

Index

A	
Attaching the Payload.....	15
C	
Cleaning.....	27
D	
Declaration of Incorporation.....	9
Dimensions.....	3
E	
Electrical Installation.....	16
Environmental Specifications.....	19
L	
limit switches.....	23
Lubrication.....	27
lubrication schedule.....	27
M	
model numbers.....	11
O	
Optional Features.....	1
P	
Preparing the Mounting Surface.....	12
S	
safety procedures.....	7
Securing the Stage to the Mounting Surface.....	13
Specifications.....	20
Standard Features.....	1
U	
Unpacking and Handling the Stage.....	11
W	
Warnings.....	7

Reader's Comments

ABRS Series Stage Manual P/N: EDS120, April 5, 2011 Revision 1.05.00 Please answer the questions below and add any suggestions for improving this document.	
---	---

Is the manual:	Yes	No
Adequate to the subject		
Well organized		
Clearly presented		
Well illustrated		

How do you use this document in your job? Does it meet your needs? What improvements, if any, would you like to see? Please be specific or cite examples.

	Stage/Product Details		Name	
Model #			Title	
Serial #			Company Name	
Date Shipped			Address	
Customer Order #				
Aerotech Subsidiary Order #			Email	

Mail your comments to:	Fax to:
Aerotech, Inc. 101 Zeta Drive Pittsburgh, PA 15238 U.S.A.	412-967-6870
	Email:
	service@aerotech.com

