

Sinewave Inverters

SWING 150VA and 300VA

User's manual



1 Warranty

RIPEnergy is not manufacturer of these units . All technical information's, data's and dimension's rely on information's given by the manufacturer. Therefore RIPEnergy AG is not responsible for the data's provided in this manual. Should work take place, which is not in accordance with guidelines, local rules, instruction's or specification's, damage may occur. All of these matters will lead to loss of warranty. RIPEnergy AG can not accept any liability for damages or costs arising due to the use of these inverters.

2 Distributor's address



The power conversion company

RIPEnergy AG, Wägitalstrasse 24, CH-8854 Siebnen, Schweiz

Tel : ++41-(0)43-818 53 85 Fax : ++41-(0)43-818 53 87

Email: info@ripenergy.ch Internet: www.RIPEnergy.ch

3 Retail dealer's address / Date of purchase

.....

.....

.....

.....

.....

.....

.....

.....

Contents

- 1 Warranty 2
- 2 Distributor’s address 2
- 3 Retail dealer’s address / Date of purchase 2
- 4 General Information 4
- 5 Use of this manual 4
- 6 Limitation of liability 4
- 7 Warranty specifications (short form) 4
- 8 Unpacking 5
- 9 Environmental protection 5
- 10 Description of the inverter 5
- 11 Block Diagram 6
- 12 Safety Information 6
 - 12.1 General information 6
 - 12.2 Working with batteries 7
- 13 Planning and mounting the inverter 7
 - 13.1 Required power draw 7
 - 13.2 Installation 7
 - 13.3 DC-Wiring 8
 - 13.4 AC-Wiring 8
 - 13.5 Grounding 8
- 14 Remote ON/OFF 8
- 15 Operation 9
- 16 LED-Display 9
- 17 Maintenance 9
- 18 Technical data 10
- 19 Trouble shooting 11
- 20 Further assistance and sending the unit for repair 11
- 21 Notes 12

4 General Information

Thank you for choosing a product supplied by RIPLEnergy AG. The product you have bought is manufactured to meet the highest quality standards. Our manufacturers have a very long experience in manufacturing of high end electronic equipment.

5 Use of this manual

This user's manual contains the information you need to install and operate this inverter correctly. Check that you have the correct manual for your unit.

It is valid for the following units :

Sinewave Inverter Swing 150-12-230 and 150-24-230
Sinewave Inverter Swing 300-12-230 and 300-24-230



Read the manual carefully before installing or operating the inverter. If you do not understand or are uncertain about any operation or information, please contact your dealer. He will be able to help you with an explanation or will demonstrate the operation.



The user must always have access to the user's manual. The latest version of the manual is provided and can be downloaded from the homepage of RIPLEnergy AG.



These inverters must be only installed by qualified, authorized and trained personnel familiar with the locally applicable standards and taking into consideration all relevant safety guidelines and measures!

Never remove the type number plate. Important technical information required for service or delivery of spare parts can be derived from the type number plate.



Modifications or breaking the warranty label without a written permission from RIPLEnergy AG means that warranty is lost immediately!

Always contact your dealer first if you have any problems.

6 Limitation of liability

RIPENERGY AG is not responsible or liable for any loss, damage or costs arising from operating these inverters.

The products supplied by RIPLEnergy AG are not for application's in any medical equipment intended for use as a component of any life support system. If products are used in such systems, a specific written agreement between the manufacturer, RIPLEnergy AG and the installer/manufacturer of the system is needed. In addition, the manufacturer of the system must agree to indemnify RIPLEnergy AG from any claims arising from use of products supplied by RIPLEnergy AG in the life support equipment.

7 Warranty specifications (short form)

The inverters are built for RIPLEnergy AG in according to the legally applicable standards. During production, and prior to delivery, all products are tested and inspected. RIPLEnergy AG is looking to find the best available products on the market. Good quality parts and the latest technology of the units will ensure a long lasting and trouble free operation of these units.

If any problem occurs during warranty period, please contact your dealer first. He is able to serve you with instructions and explains you how to send the unit to the nearest service center, if necessary.

Warranty can only be guaranteed if you enclose a document (Invoice or delivery documents) to the defective units.

Damage attributable to normal wear and tear, overload or improper handling or installation is not covered by the warranty.

Modifications or breaking the warranty label without a written permission from RIPLEnergy AG means that the warranty is lost immediately!

Always return the units in it's original package and completely assembled. A short description of the failure/problem will help us to serve you better (see also instructions on item 20).

RIPLEnergy AG is not paying for costs arising for transport of the unit or damage that arise during the time the unit is unserviceable. The general terms of delivery and terms of sale of RIPLEnergy AG are valid.

8 Unpacking

After unpacking, carefully check the inverter for possible damage. If any damage due to transport is visible immediately contact your dealer for further instructions.



Keep the original packing in case you need it to transport the inverter later.

9 Environmental protection

RIPLEnergy AG continually commits a considerable part of its resources towards minimizing the environmental impact of its products. The inverter is manufactured with valuable materials and easy to recycle.

10 Description of the inverter

The model Swing 150VA and Swing 300VA pure sinewave inverter supplies a 230VAC output voltage either from a 12V or 24V VDC power source. The shape of the output voltage is pure sinewave - clean power as from the grid.

The inverter design is based on proven 50Hz-technologie. All functions are controlled by a microprocessor. Extra input and output filtering to reduce EMI to extremely low levels. Reliability features include an input fuse, thermal shutdown, current limiting and output short circuit shutdown with automatic recovery.

The input and output is fully isolated. The superb overload capability supplies short time peak power to start heavy equipment such as pumps and compressors.

11 Block Diagram

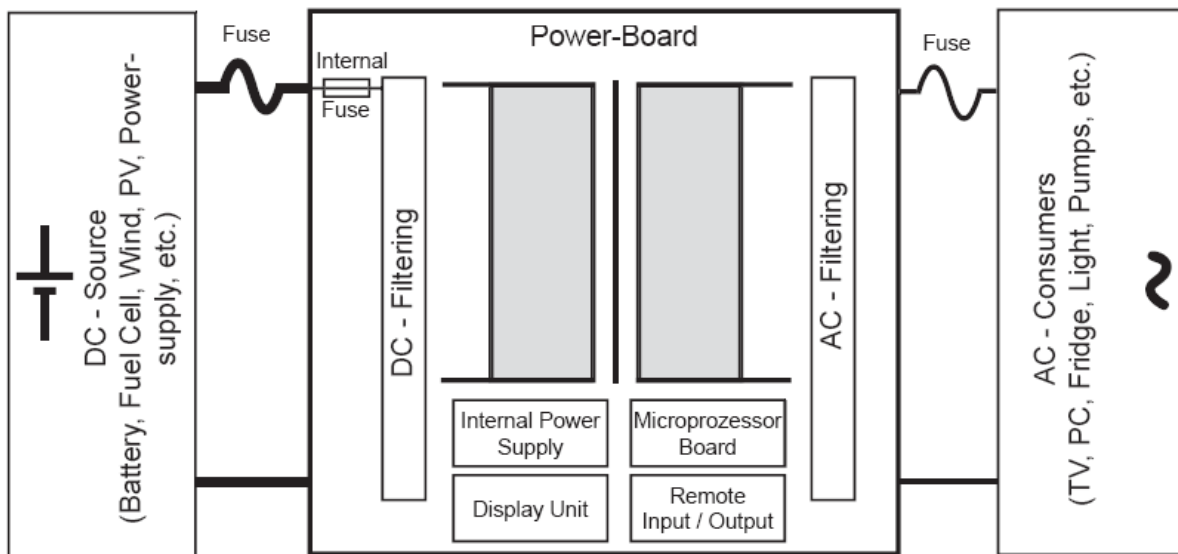

12 Safety Information

12.1 General information

Read the manual carefully before installing or operating the inverter. If you do not understand or are uncertain about any operation or information please contact your dealer. Before installation you must be aware of local standards and rules applicable to use such equipment. For installation and use of the inverter pay attention to local applicable standards, all relevant safety guidelines and measures. These rules may be different to the information's provided in this manual.

High voltages up to 1200V inside the inverter! Never open the enclosure. High voltage may harm or even kill persons or animals. Never touch wires or blank connectors. Do not operate the inverter with damaged or substandard wiring.

Check local standards for lightning protection of inverter systems.

No other inverter output, AC-Generator or other AC-Source may be connected to the inverters AC-Output. The inverter will be destroyed immediately!

The enclosure may heat up to 80°C! Never obstruct louvers nor place other items on the inverters enclosure. If ventilation is not sufficient the unit may overheat and an automatic shut off may occur.

Even if DC-Wiring is not longer connected to the batteries, inbuilt large capacitors may hold Dc-Voltage for an extended period of time. The inverter may only be opened by skilled and authorized personnel.

Modifications or breaking the warranty label without a written permission from RIEnergy AG means that warranty is lost immediately!

The inverter contains components which can produce arks and sparks. To prevent fire or explosion, do not install or operate in compartments containing batteries or flammable materials. Never use or operate the unit where there is danger of gas- or dust explosion.

After automatic shut down of the inverter because of any failure the inverter may switch ON automatic again. The OFF period is depending on what causes the shut down and may vary from only seconds to several minutes.

12.2 Working with batteries

Using batteries in a wrong way may result in danger for personnel, animals or the environment. Check information from battery manufacturer for safe installation and operation.

If battery acid contacts skin or clothing, wash immediately with soap and water. If acid contacts eyes, immediately flush with running cold water for at least 20 minutes and get medical attention as soon as possible.

Never smoke or allow a spark or flame in vicinity of batteries.

Do not drop metal tools on batteries. The resulting spark or short circuit may cause an explosion.

Remove personal metal items such as rings, bracelets, necklaces and watches when working with batteries.

13 Planning and mounting the inverter

This section will provide you information's about configuring and installing your inverter. Make sure that you are aware of local rules and safety measurements.

13.1 Required power draw

Before connecting your appliances to the inverter, always check the power draw required. The inverter is affordable to supply surge power for a short time, so as to start up electrical equipment such as pumps, motors, etc. Some equipment needs more power while starting up.

The inverter is protected against overload and will switch off automatically when overload is applied. As ambient temperature is above 20°C the inverters nominal power may be smaller due to reduced cooling.

Using the inverter in high altitudes may also reduce nominal power of the inverter because of less heat discharge. As a rule of thumb, the reduction of nominal power is approximately 1.5% per 100m elevation.

13.2 Installation

These units must be only installed by qualified, authorized and trained personnel familiar with the locally applicable standards and taking into consideration all relevant safety guidelines and measures!

Before installing the unit check for correct DC-Voltage and power level of the inverter.

The Inverter may be installed in any position. Install the inverter in a dry, well ventilated and dust free location. It must be installed out of reach for unauthorized personnel especially children's. Do not install the inverter in the same compartment as the batteries.

Never use or install the inverter in locations where there is gas or explosive danger!

For proper cooling of the Inverter ensure that the airflow is not obstructed and keep a clearance distance of 2.5cm to other units. If the inverter is installed in a closed compartment the nominal power may be reduced.

In order to keep the battery cables as short as possible (max. 6m) locate the inverter close to the DC-Distribution or Battery. Be aware that during charging of batteries an explosive gas can be generated.

13.3 DC-Wiring

Position of the switch on the front panel must be OFF.

A high power fuse must be installed direct to the battery to protect the DC-Wiring (not for Swing 150-12-230). DC – current according to the datasheet.

Not installing a fuse may result in melting or even burning DC-Cables in case of excessive overload or failure of the inverter.

The way of wiring has influence on the EMC behaviour of the system. Most problems using inverter are because of unprofessional wiring. Lay the cables in a metal duct. If this is not possible the cables should be twisted and lay parallel to a metal bar.

To thin cable or loose connections can cause dangerous overheating of cables or terminals. Always use DC cables of the correct size to avoid fire and other damage.

To define the size of cable, we provide a “Cable Size Calculator” on our website for free use.

Only SWING 150-12-230

DC-Connector already mounted to DC-Cable. Do not remove. It is for use with cigarette lighter output in your car. Check the fuse of your car for correct size (>15A).

Connect the cables with care to the battery/inline fuse. If possible use coloured cables. Red colour means battery positive, while black is used for battery negative. Reversing positive and negative will cause major damage to the inverter and is not covered by warranty.

Note: Large capacitors in the units may hold DC-Voltage for a long period of time. Also a spark may occur while connecting the DC-cables or inserting the DC-Fuse after installation. This is normal.

If you connect other consumers to the battery contact your dealer.

13.4 AC-Wiring

Use the included AC-Connector to connect the AC-Load to the output of the inverter.

Even the inverter is protected against overload and short circuit, we recommend to use an AC-Circuit breaker of correct size.

For safe operation it is necessary to connect earth (PE) and neutral (N) of the inverter output to central ground of the inverter.

Even more safe is to use a 15mA or 30mA earth leakage switch in the AC-Installation.

13.5 Grounding

The earth wire protection is only possible if the inverter enclosure is also connected to earth. Use a . 8-10mm² cable (AWG 8) and connect it to the earth terminal of the inverter. This is also important for lightning protection.

14 Remote ON/OFF

Use a cable (0.75mm²) and standard switch for remote controlled ON/OFF of the Inverter. Connect the cable to the provided remote terminals on the inverter.

The main switch on the front panel of the inverter, must be in the “remote” position when using the remote switch to control the inverter.

15 Operation

The Inverter is controlled by a single three position switch located on the front panel of the inverter.

Engaging

Switch to "ON-Position". The green LED will illuminate. The Inverter is ready to use.

Power down

Switch to „OFF-Position“. All LED's are dark. The inverter is OFF.

Remark

Even if the inverter is switched to off, it is not disconnected from the battery. It still draws very little power from the battery. If you don't need the inverter for an extended period disconnect it from the battery to avoid low discharge of battery.

Before using the remote cable to control the inverter, the main switch must be in the „REMOTE-Position“.

16 LED-Display

Steady greenAC-Output OK

Flashing fast red Cut Off caused by DC-Over voltage

Flashing slow red..... Cut Off caused by DC-Low voltage

Steady red Cut Off caused by overload

Flashing intermittently red Cut Off caused by over temperature

17 Maintenance

Only little maintenance is required to keep your inverter and system operating reliable. The inverter must be switched off during maintenance and/or repair activities. It also must be secured against unexpected and unintentional switching on. Therefore switch off the connection between batteries and inverter and be sure that third parties cannot reverse the measures taken.

The following Steps must be undertaken at least once a year. Check cable and wires for damage and if they are still firmly connected. Defects such as loose connections ore damaged cables etc. must be corrected immediately. Keep the inverter dry, clean it from dust in order to ensure good heat discharge.

18 Technical data

150VA

Electrical (output)

Nominal VAC	230 +/- 5%
Output Frequency	50Hz +/- 0.3%
Nominal power	150VA continuous
Nominal current	0.65A (230VAC @ nominal Power)
Power for 3 min.	200VA
Peak Power	250VA
Output Waveform	Pure Sinewave
Protection circuitry	Short circuit, Overload, Overtemperature
Indicators	Overload, Overtemperature
Power Factor	0.4 - 1 (COS Phi)

Environmental Specifications

Operating Temp. Range	-10° to +40°C @ maximum output Derating Linearly 4% per °C from 40°C
Humidity	0 - 95% Relative Humidity (non-condensing)
Audible Noise	NONE, 0db @ 1m (Fan OFF)
Fan	Load and temperature controlled (65°C ON, 45°C OFF)
Isolation	Input-Output 1100VDC, Input-Case 1100VDC Output-Case 500VDC

Electrical (input)

Nominal voltage (VDC)	12	24
Voltage range (VDC)	10.5 - 15	21 - 30
Amps @ Pnom (A)	14	6.5
Protection circuitry	Overvoltage, Lowvoltage	
Idle current 230V ON (A)	0.22	0.17
Efficiency max.	91%	93%
Efficiency @full load	72%	80%
Indicators	Overvoltage, Lowvoltage	

Mechanical Specifications

Length	20.0 cm
Width	13.2 cm
Height	7.2 cm
Clearance	2.5 cm all around
Material	Aluminium
Finish	Black Anodize / Powder Epoxy Coat
Weight	2.7 Kg
Connections	12V DC-Car-Plug, 24V DC-cable, AC-connector (Connector supplied with inverter)
Warranty	2 years
Standards	Approval to CE, e-Mark

300VA

Electrical (output)

Nominal VAC	230 +/- 5%
Output Frequency	50Hz +/- 0.3%
Nominal power	300VA continuous
Nominal current	1.3A (230VAC @ nominal Power)
Power for 3 min.	360VA
Peak Power	500VA
Output Waveform	Pure Sinewave
Protection circuitry	Short circuit, Overload, Overtemperature
Indicators	Overload, Overtemperature
Power Factor	0.4 - 1 (COS Phi)

Environmental Specifications

Operating Temp. Range	-10° to +40°C @ maximum output Derating Linearly 4% per °C from 40°C
Humidity	0 - 95% Relative Humidity (non-condensing)
Audible Noise	NONE, 0db @ 1m (Fan OFF)
Fan	Load and temperature controlled (65°C ON, 45°C OFF)
Isolation	Input-Output 1100VDC, Input-Case 1100VDC Output-Case 500VDC

Electrical (input)

Nominal voltage (VDC)	12	24
Voltage range (VDC)	10.5 - 15	21 - 30
Amps @ Pnom (A)	27	13
Protection circuitry	Overvoltage, Lowvoltage	
Idle current 230V ON (A)	0.25	0.19
Efficiency max.	91%	94%
Efficiency @full load	72%	80%
Indicators	Overvoltage, Lowvoltage	

Mechanical Specifications

Length	23.7 cm
Width	15.5 cm
Height	7.2 cm
Clearance	2.5 cm all around
Material	Aluminium
Finish	Black Anodize / Powder Epoxy Coat
Weight	3.5 Kg
Connections	DC-cable, AC-connector (Connector supplied with inverter)
Warranty	2 years
Standards	Approval to CE, e-Mark

19 Trouble shooting

Warning – Never remove the cover of the inverter! Do not self repair the inverter, no serviceable parts are inside the unit.

No function	<p>Check LED-Display to identify the reason. According the failure indicated by the display see sections below to solve the problem. Check wiring for correct size, damage or loose screws. Check batteries, battery fuse or fuse installed on AC-output. If switch is in remote position but no remote cable is connected , switch it to the „ON-Position“.</p>
DC-Low voltage	<p>The battery voltage dropped below 1.75V/Cell. Check battery fuse. Charge the battery – if charging is not solving the problem maybe the battery is defect. The wiring may be too thin or check installation for loose connections. Note: If battery voltage rises above 2.1V/Cell, the inverter restarts automatically.</p>
DC-Over voltage	<p>The battery voltage is above 2.55V/Cell. Remove the battery charger and stop charging the battery. Note: If battery voltage is dropping below 2.5V/Cell the inverter restarts automatically.</p>
Over temperature	<p>If load is smaller than nominal power of inverter – check if ventilation of the inverter is blocked. Maybe the ambient temperature is too high. If load is exceeding nominal power of inverter – reduce the load. Note: The inverter will switch on automatically if temperature of the inverter is within normal operating temperature range.</p>
Overload	<p>Reduce load. Remove unnecessary consumers. Reset the inverter with the front panel switch OFF than ON.</p>
Other failures	<p>Check system for correct grounding or contact your dealer.</p>

V/Cell: The nominal voltage using lead acid batteries is 2VDC/Cell. Example: A 12V-Battery contains 6 single cells, a 24V-Battery contains 12 single cells etc.

20 Further assistance and sending the unit for repair

In the rare case the unit is not working contact your dealer providing him some details as:

1. Check Battery voltage, wiring and display for possible failures.
2. Note: Type of unit and serial number.
3. Now call your dealer or nearest service center.
They will help you with further instruction's.
4. If he is recommend to send the unit for repair use the original packing.
Include a copy of invoice (Warranty repair is only possible with a copy of invoice or certificate showing date of purchase) and a short notice about your system and the failure observed.
5. In case you have to send the unit above state borders please make sure to fill the correct papers needed for customs. To reduce time and save money contact the consignee how to declare the delivery. Arising costs for customs has to be paid by the sender.
6. An actual list of authorized service center will be provided at our homepage www.ripenergy.ch

21 Notes

.....
.....
.....
.....
.....
.....
.....
.....
.....
.....
.....
.....
.....
.....
.....
.....
.....
.....
.....
.....
.....