

# MDC010 - 050101

## 50V, 10A Brushless Controller

### User's Guide



**A N A H E I M A U T O M A T I O N**

910 East Orangefair Lane, Anaheim, CA 92801  
e-mail: [info@anaheimautomation.com](mailto:info@anaheimautomation.com)

(714) 992-6990 fax: (714) 992-0471  
website: [www.anaheimautomation.com](http://www.anaheimautomation.com)

## MDC010-050101 Speed Controller Features

- 1 Quadrant Digital Speed Control
- 6-50 VDC Voltage Range
- Max Speed at 80,000rpm
- Maximum current of 10A (5A rated)
- Digital Signal presets Direction of Rotation
- Protection Against Thermal Overload
- Small Design
- Motor Blockage Protection
- Status Indication
- Easy Connectivity/Integration into Motherboard

## General Description

The MDC010-050101 has a very compact design with a high efficiency speed controller that offers a operating voltage of 50VDC, while maintaining an output current of 5A. The amplifier also offers a large number of inputs and outputs such as the speed monitor, current limiting, speed ranges, direction of rotation presetting, enable, operating status, etc. While offering all these features the MDC010-050101 offers many protective features against overcurrent, undervoltage and overvoltage, short circuit and thermal overload to ensure the controller runs correctly. Anaheim Automation also offers an MDC010-EVALBOARD for initial start-up.

## Pin Assignment

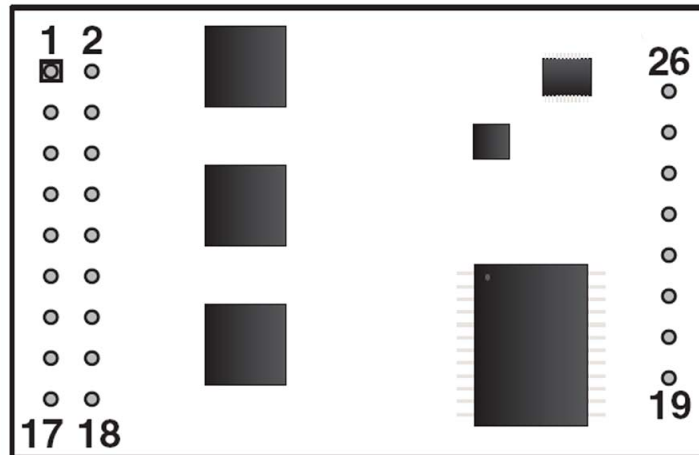

# Specifications

## Electrical Data

Nominal Supply Voltage (V) - 6-50VDC  
Absolute Minimum Supply Voltage (V) - 6VDC  
Absolute Maximum Supply voltage (V) - 55VDC  
Max. Output Voltage - 0.95V  
Continuous Output Current (I) - 5A  
Max. Output Current (I) - 10A  
Switching Frequency - 46.8kHz  
Max. Speed (motor with 1 pole pair) - 80,000rpm

## Inputs

Set value Speed - Analogue input (0-5V); Resolution: 1024 Steps  
Enable - +2.4-+55V (R=100kohms) or switch against V  
Direction - +2.4-+28V(R=100kohms) or switch against V  
Speed Range <<DignIN1>> - +2.4-+55V(R=47kohms at 5V) or switch against Gnd  
Speed Range <<DignIN2>> - +2.4-+55V(R=47kohms at 5V) or switch against Gnd  
Set Current Limit - External Resistor (1/16 W) against Gnd  
Hall Sensors - <<Hall Sensor 1>>, <<Hall Sensor>>, <<Hall Sensor 3>>

## Output

Motor Speed <<Monitor n>> - Digital Output Signal, 5V(R=47kohms)  
Status Indication <<Ready>> - Digital Output Signal, 5V(R=47kohms)

## Voltage Output

+5 VDC Output Voltage <<V Hall>> - +5 VDC, man. 35 mA

## Motor Connections

Motor Connections - <<Motor Winding 1 (Phase A) >>, <<Motor Winding 2 (Phase B) >>, <<Motor Winding 3 (Phase C) >>

## Ambient Temperature

Operation - -10-+45°C  
Storage - -40-+85°C

## Humidity Range

Non condensating - 20-80%

## Protective Functions

Current Limitation (cycle-by-cycle) - Adjustable up to Maximum 10A  
Blockage - Motor Current limitation if motor shaft is blocked for longer than 1.5s  
Undervoltage shutdown - Shutdown if V<6VDC  
Overvoltage Shutdown - Shutdown if V>56VDC  
Thermal Overload Protection of Power Stage - Shutdown if T>100°C

## Mechanical Data

Weight - approx. 9g  
Dimensions - 43.18 x 27.94 x 12.7mm (1.7 x 1.1 x 0.5in)

## Terminals

Pin header 1 - 2 x 9 pins (Double-Row, pitch 2.54mm (0.1in))  
Pin header 2 - 8 pins (Single Row, pitch 2.54mm (0.1in))

## Inputs

### Speed Range and Mode selection with <<DigIN1>> and <DigIN2>>

The digital inputs <<DigIN1>> [20] and <<DigIN2>> [21] determine both, the operation mode (digital speed controller or digital speed actuator) and the speed range in speed set value mode.

DigIN1	DigIN2	1 Pole Pair	4 Pole Pair	8 Pole Pair
0	0	Open Loop Speed Control, 0-95% PWM Depending on the <<Set value speed>> Input Voltage		
1	0	500-5,000 rpm	125-1,250 rpm	62-625 rpm
0	1	500-20,000 rpm	125-5,000 rpm	62-2,500 rpm
1	1	500-80,000 rpm	125-20,000 rpm	62-10,000 rpm

### Please Note

If the signal level of the digital inputs DigIN1 [20] and DigIN2 [21] are changed, the new levels are adopted by a disable-enable procedure.

If the input <<Dig>> is not connected (floating) or a voltage higher than 2.4V is applied, the input is inactive.		
Logic 1	Input not connected (floating) Input voltage > 2.4V	Input Active
	If the input <<DigIN>> is set to ground potential or a voltage smaller than 0.8V is applied, the digital input is inactive	
Logic 0	Input set to Gnd Input Voltage < 0.8V	Input Inactive
	The inputs <<DigIN1>> and <<DigIN2>> are protected against overvoltage.	
	Digital input 1	Pin Number [20] <<DigIN1>>
	Digital input 2	Pin number [21] <<DigIN2>>
	Input Voltage Range	0-+5V
	Input Impedance	47kohms pull-up resistor against 5V
	Continuous Overvoltage Protection	-55-+55V

### Set Value <<Set Value Speed>>

The external analogue set value is predetermined at the <<Set value speed>> input [26]. The <<Set value speed>> input sets the rotational speed of the motor shaft.

By adjusting the signal levels on digital inputs <<DigIN1 [20]>> and <<DigIN2 [21]>> the speed range must be set in advance.

DigIN1	DigIN2	1 Pole Pair	4 Pole Pair	8 Pole Pair
0	0	Open Loop Speed Control, 0-95% PWM Depending on the <<Set value speed>> Input Voltage		
1	0	500-5,000 rpm	125-1,250 rpm	62-625 rpm
0	1	500-20,000 rpm	125-5,000 rpm	62-2,500 rpm
1	1	500-80,000 rpm	125-20,000 pm	62-10,000 rpm

**Note**

If the level of the digital inputs DigIN1 [20] and DigIN2 [21] are changed, the new levels are adopted by a disable-enable procedure.

Set Value Voltage	Description
0-0.1V	Operation at minimum speed
0.1-5.0V	Linear speed adjustment

The actual speed value is calculated according the following formula:

**Known Values**

Minimum speed (see table above)  $n_{min}$  [rpm]

Maximum speed (see table above)  $n_{max}$  [rpm]

Set value voltage  $V_{set}$  [V] respectively speed  $n$  [rpm]

Sought Value

Sought Value

Speed  $n$  [rpm]

Set value voltage [V]

Solution

Solution

$$n = \left[ \frac{V_{set} - 0.1[V]}{4.9[V]} \cdot (n_{max} - n_{min}) \right] + n_{min} \quad V_{set} = \left( \frac{n - n_{min}}{n_{max} - n_{min}} \cdot 4.9[V] \right) + 0.1[V]$$

The <<Set value Speed>> input is protected against overvoltage.

Set Value Speed Input	Pin number [26] <<Set Value Speed>>
Input Voltage	0-+5V (reference to Gnd)
Resolution	1024 steps (4.88mV)
Input Impedance	107kohms (in range 0-+5V)
Continuous Overvoltage Protection	-55-+55V

### <<Enable>>

The <<Enable>> input enables or disables the power stage.

If a voltage higher than 2.4V is applied to the <<Enable>> input, the amplifier is activated (Enable). A speed ramp will be performed during acceleration.		
Enable	Input Voltage>2.4V	Motor Shaft Running
	If the input is not connected (floating) or ground potential is applied to the <<Enable>> input, the power stage is high impedant and the motor shaft freewheels and slows down (Disable).	
Disable	Input not connected (floating) Input set to Gnd Input Voltage<0.8V	Power Stage Switched Off
	The <<Enable>> input is protected against overvoltage.	
	Enable	Pin Number [22] <<Enable>>
	Input Voltage Range	0-+5V
	Input Impedence	100kohms (in range 0-+5V)
	Continuous Overvoltage Protection	-55-+55V
	Delay time	Max. 40ms

### <<Direction>>

The <<Direction>> input determines the rotational direction of the motor shaft. When the level changes, the motor shaft slow down with a ramp to standstill, and accelerates with a speed ramp in the opposite direction, until the target speed is reached again.

If the input is not connected (floating) or ground potential is applied to the <<Direction>> input, the motor shaft runs clockwise (CW).		
CW	Input not connected (floating) Input set to Gnd Input voltage<0.8V	Clockwise (Wise)
	If a voltage higher than 2.4V is applied to the <<Direction>> input, the motor shaft runs counter-clockwise (CCW).	
CCW	Input Voltage>2.4V	Counter-Clockwise (CCW)
	The <<Direction>> Input is protected against overvoltage.	
	Direction	Pin Number [23] <<Direction>>
	Input Voltage Range	0-+5V
	Input Impedence	100kohms (in range 0-+5V)
	Continuous Overvoltage Protection	-55-+55V
	Delay Time	Max. 40ms

**<<Set Current Limit>>**

The <<Set Current Limit>> input is used for setting the continuous output current limitation in the range of 0.5-10A.

The current set at the input <<Set Current Limit>> will stay available for an indefinite period of time.

**Note**

The limiting value should be below the rated motor current (max.continuous current).

Set Value Current	Pin Number [25] <<Set Current Limit>>
Referenced to Ground	Pin Number [24] <<Gnd>>

Current Limit Value	Resistance Value (E24 Series)
10A	Input Floating
9A	220 kohms
8A	91 kohms
7A	56 kohms
6A	36 kohms
5A	24 kohms
4A	16kohms
3A	10.0 kohms
2A	5.6 kohms
1A	2.7 kohms
0.5A	1.2 kohms

To parameterize the preferred current limiting value, an external resistor (at least 62.5 mW) between current limiting input <<Set Current Limit>> Pin [25] and ground <<Gnd>> Pin [24] must be added.

**<<Hall Sensor 1>>, <<Hall Sensor 2>>, <<Hall Sensor 3>>**

The <<Set Current Limit>> input is used for setting the continuous output current limitation in the range of 0.5-10A.

Hall Sensor 1	Pin number [13] <<Hall Sensor 1>>
Hall Sensor 2	Pin number [15] <<Hall Sensor 2>>.
Hall Sensor 3	Pin number [17] <<Hall Sensor 3>>
Input Voltage Range	0-+5V
Input Impedance	22 kohms pull-up resistors to 5V
Voltage Level <<Low>>	Max. 0.8V
Voltage Level <<High>>	Min. 2.4V
Continuous Voltage	-30-+30V

Suitable for Hall Sensors IC's with Schmitt-Trigger behavior and open collector or push-pull outputs.

## Outputs

### +5 VDC Output Voltage <<V<sub>cc</sub> Hall>>

An internal auxiliary voltage of +5VDC is provided for:

- Hall Sensor supply voltage <<V<sub>cc</sub> Hall>>
- For external set value potentiometer (recommended value: 10kohms)
- Gating the signals: <<Enable>> and <<Direction>>

The output is protected against continuous short circuit.

+5 VDC Output Voltage	Pin Number [25] <<Set Current Limit>>
Referenced to Ground	Pin Number [24] <<Gnd>>
Output Voltage	+5VDC 5%
Max. Output Current	35mA

### Motor Speed Monitor <<Monitor n>>

The <<Monitor n>> output gives information on the actual speed of the motor shaft. The actual speed is available as a digital frequency signal (high/low). The output <<Monitor n>> is protected against continuous short circuit.

Motor Speed Monitor	Pin number [18] <<Monitor n >>
Output Voltage Range	0-+5V
Output Impedance	47kohms

### Known Values

- Number of poles pairs of motors  $z_{pol}$
- Frequency at <<Monitor n>> output [Hz] respectively Speed n [rpm]

Sought Value

Sought Value

Frequency at <<Monitor n>> [Hz]

Speed n [rpm]

Solution

Solution

$$f_{Monitor\ n} = \frac{n \cdot z_{pol}}{20} \quad [Hz]$$

$$n = \frac{f_{Monitor\ n} \cdot 20}{z_{pol}} \quad [min^{-1}]$$



## Status Indication <<Ready>>

The <<Ready>> output can be used to report the state of operational readiness or a fault condition to a master control unit.

In normal cases (no fault) the output is switched to 5V.	
Ready (no fault)	5V
In case of a fault the output is switched to Ground.	
Fault (not ready)	0V (Gnd)

Possible reasons for a fault message:

Undervoltage	Fault message occurs in case supply voltage $+V < 6VDC$ . To reset the fault condition the amplifier must be disabled and the supply voltage $+V$ must be higher than 6VDC.
Overvoltage	Fault message occurs in case supply voltage $+V > 56VDC$ . To reset the fault condition the amplifier must be disabled and the power stage temperature must fall below 80deg Celcius.
Thermal Overload	Fault message occurs in case power stage temperature is $> 100deg$ Celcius. To reset the fault condition the amplifier must be disable and the power stage temperature must fall below 80deg Celcius.
Invalid Hall Sensor Signals	The amplifier recognizes invalid conditions at the Hall Sensor inputs. To reset the fault condition the amplifier must be disable and the Hall Sensors must be wired correctly.

The output <<Ready>> is protected against continuous short circuit.

Status Indication	Pin number [19] <<Ready>>
Output Voltage Range	0-+5V
Output Resistance	47kohms

## Protective Features

### Undervoltage Protection

The power stage will be disabled in case the supply voltage  $+V_{cc}$  drops below 6VDC. To reset the fault condition the amplifier must be disabled and the supply voltage  $+V_{cc}$  must be higher than 6VDC.

### Overvoltage Protection

The power stage will be disabled in case the supply voltage  $+V_{cc}$  rises above 56VDC. To reset the fault condition the amplifier must be disabled and the supply voltage  $+V_{cc}$  must be lower than 54VDC.

### Thermal Overload Protection

The power stage will be disabled in case the power stage temperature exceeds 100°C. To reset the fault condition the amplifier must be disabled and the power stage temperature must fall to 80°C.

### Invalid Hall Sensor Signals

The power stage will be disabled in case invalid conditions at the hall sensor inputs occur. To reset the fault condition the amplifier must be disabled and the hall sensors must be wired correctly.

### Blockage Protection

If the motor shaft is blocked for longer than 1.5s, the current limit is set to the predetermined value at the <<Set Current Limit>> input.

Definition <<Motor shaft blocked>>: A speed lower than 4154rpm (motor with 1 pole pair) occurs for longer than 1.5s.

Note:

- No fault message occurs at the <<Ready>> output if blockage protection is active.

### Current Limitation

The motor current will be limited to 0.5-10A depending on the value applied to the input <<Set Current Limit>> by means of a cycle-to-cycle limitation.

Note:

- No fault message occurs at the <<Ready>> output if current limitation is active.

# Typical Hookup Drawing

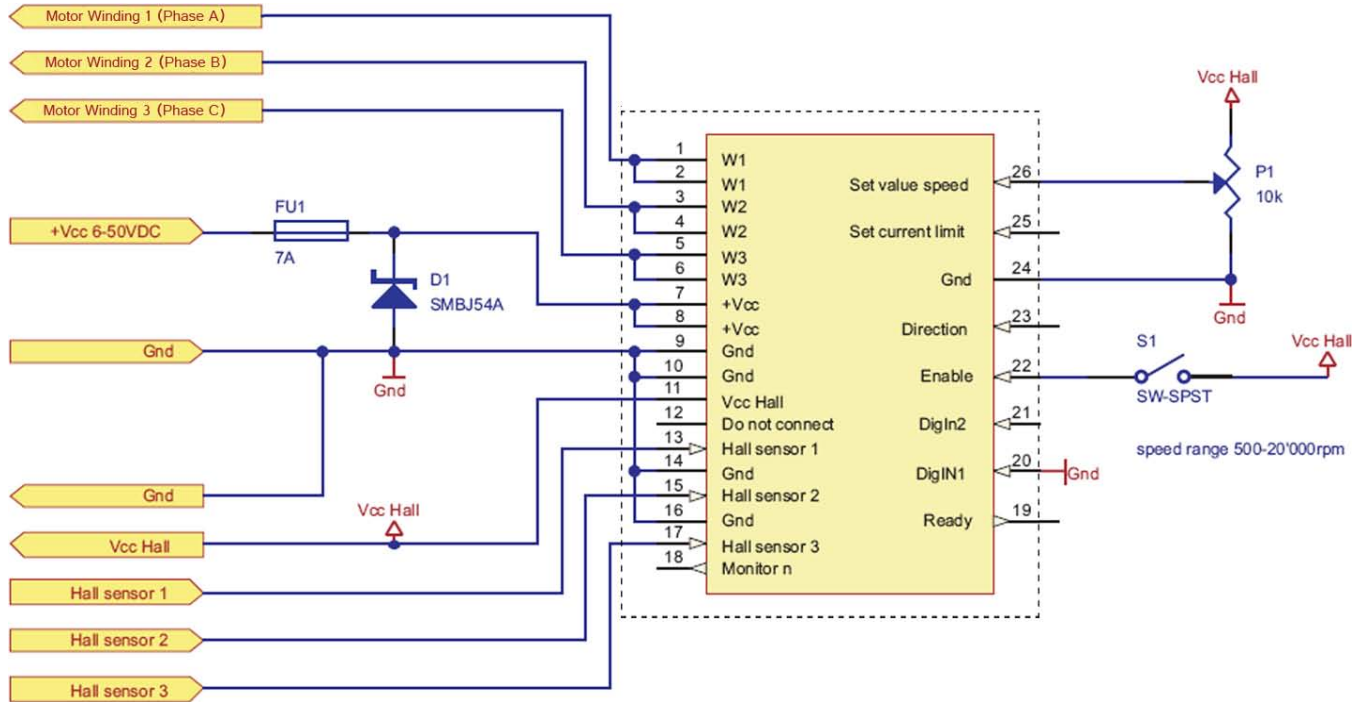

# Dimensions

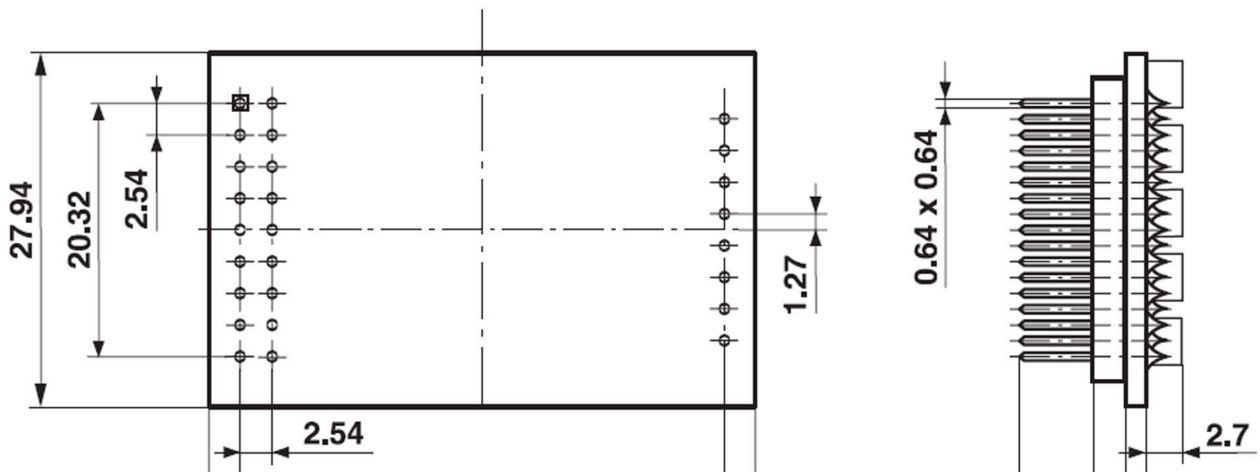

## Torque Speed Curves

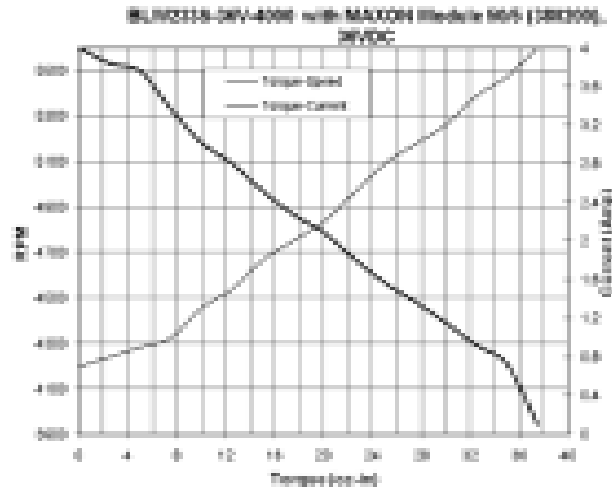

### COPYRIGHT

Copyright 2006 by Anaheim Automation. All rights reserved. No part of this publication may be reproduced, transmitted, transcribed, stored in a retrieval system, or translated into any language, in any form or by any means, electronic, mechanical, magnetic, optical, chemical, manual, or otherwise, without the prior written permission of Anaheim Automation, 910 E. Orangefair Lane, Anaheim, CA 92801.

### DISCLAIMER

Though every effort has been made to supply complete and accurate information in this manual, the contents are subject to change without notice or obligation to inform the buyer. **In no event will Anaheim Automation be liable for direct, indirect, special, incidental, or consequential damages arising out of the use or inability to use the product or documentation.**

Anaheim Automation's general policy does not recommend the use of its' products in life support applications wherein a failure or malfunction of the product may directly threaten life or injury. Per Anaheim Automation's Terms and Conditions, the user of Anaheim Automation products in life support applications assumes all risks of such use and indemnifies Anaheim Automation against all damages.

### LIMITED WARRANTY

All Anaheim Automation products are warranted against defects in workmanship, materials and construction, when used under Normal Operating Conditions and when used in accordance with specifications. This warranty shall be in effect for a period of twelve months from the date of purchase or eighteen months from the date of manufacture, whichever comes first. **Warranty provisions may be voided if products are subjected to physical modifications, damage, abuse, or misuse.**

Anaheim Automation will repair or replace at its' option, any product which has been found to be defective and is within the warranty period, provided that the item is shipped freight prepaid, with previous authorization (RMA#) to Anaheim Automation's plant in Anaheim, California.

### TECHNICAL SUPPORT

If you should require technical support or if you have problems using any of the equipment covered by this manual, please read the manual completely to see if it will answer the questions you have. If you need assistance beyond what this manual can provide, contact your Local Distributor where you purchased the unit, or contact the factory direct.

# ANAHEIM AUTOMATION