

**SLIMLINE 2500
OWNER'S MANUAL**

*Whisper***KOOL**[™]
The Coolest Thing In Wine Storage

SL 060815

Conforms to ANSI/UL Std 427

Certified to CAN/CSA Std C22.2 No. 120

We manufacture, test and certify 100% of our wine cooling units in the USA. By sourcing the best components and closely controlling our manufacturing processes, we can assure the highest-quality, lowest defect manufacturing rates in the industry.

Copyright © 2012. WhisperKOOL. All rights reserved.

WhisperKOOL copyrights this manual, the product design, and the design concepts, with all rights reserved. Your rights with regard to the hardware and manual are subject to the restrictions and limitations imposed by the copyright laws of the USA. Under copyright laws, this manual may not be copied, reproduced, translated, transmitted, or reduced to any printed or electronic medium or to any machine-readable form, for any purpose, in whole or in part, without the written consent of WhisperKOOL.

Every effort has been made to ensure that the information in this manual is accurate. WhisperKOOL is not responsible for printing or clerical errors.

WhisperKOOL reserves the right to make corrections or improvements to the information provided and to the related hardware at any time, without notice.

Vinothèque and WhisperKOOL are registered trademarks, and ECE is a trademark of WhisperKOOL. All rights reserved.

Mention of third-party products is for informational purposes only and constitutes neither an endorsement nor a recommendation. WhisperKOOL assumes no liability with regard to the performance or use of these products.

REV 02

SL 092315

TABLE OF CONTENTS

Quick Reference Guide	
Unit	2
Controller & Specifications	3
Introduction	4
Receiving & Inspecting The Unit	5
Quick Start Guide	6
Preparing the Wine Cellar	7
Through-the-Wall Installation	
Pre-Installation	10
Preparing the Installation Location	11
Installation	12
Liquid Measuring Thermostat System	14
System Operation	15
Control Functions	16
Maintenance Schedule	17
Troubleshooting Guide	18
Technical Assistance & Accessories	22
Installation Terms and Conditions	23

QUICK REFERENCE GUIDE

Front / Side View (in cellar / evaporator)

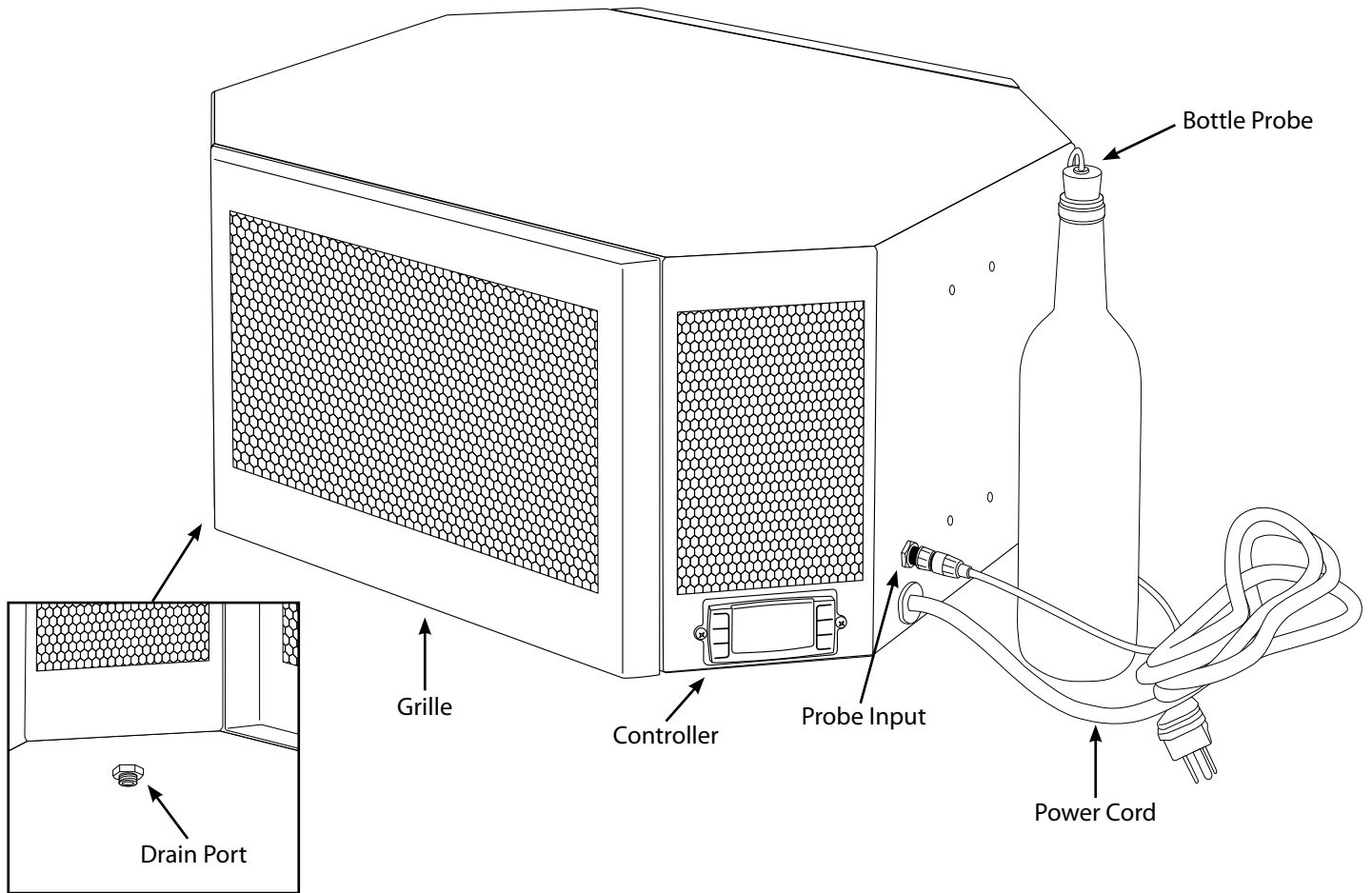

Bottom View

Rear / Side View (out of cellar / condenser)

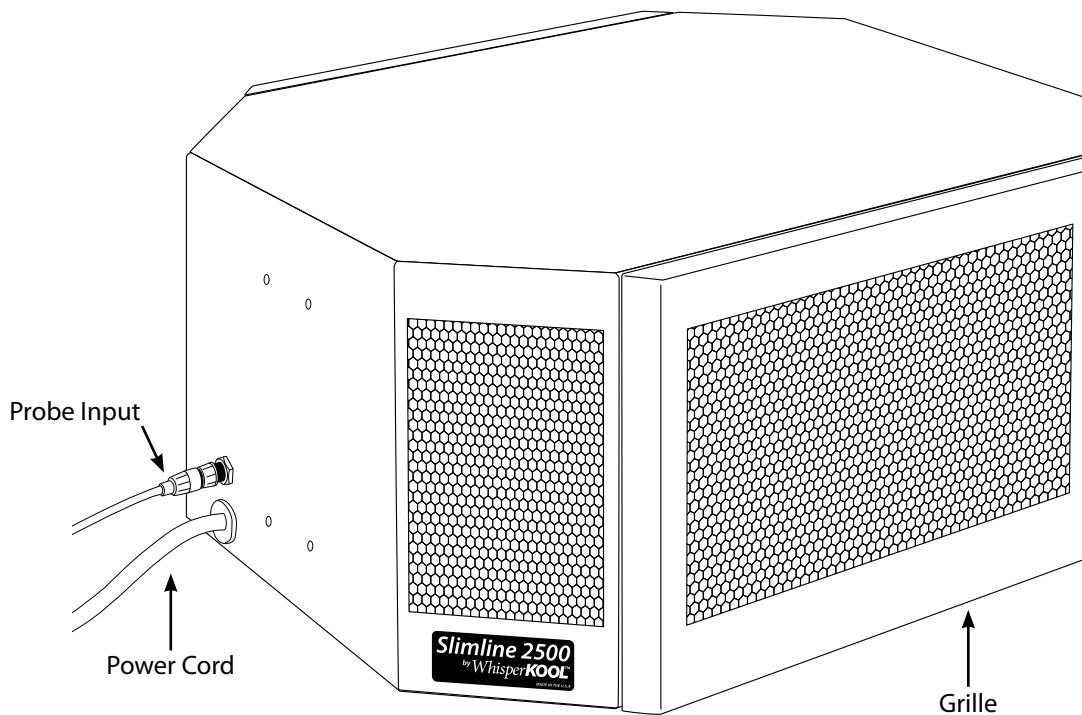

QUICK REFERENCE GUIDE

Note: The 1 or 3-5 qualifies the amount of time in seconds that the button must be pushed to activate the feature.

Refer to page 15 for complete listing of buttons and symbols.

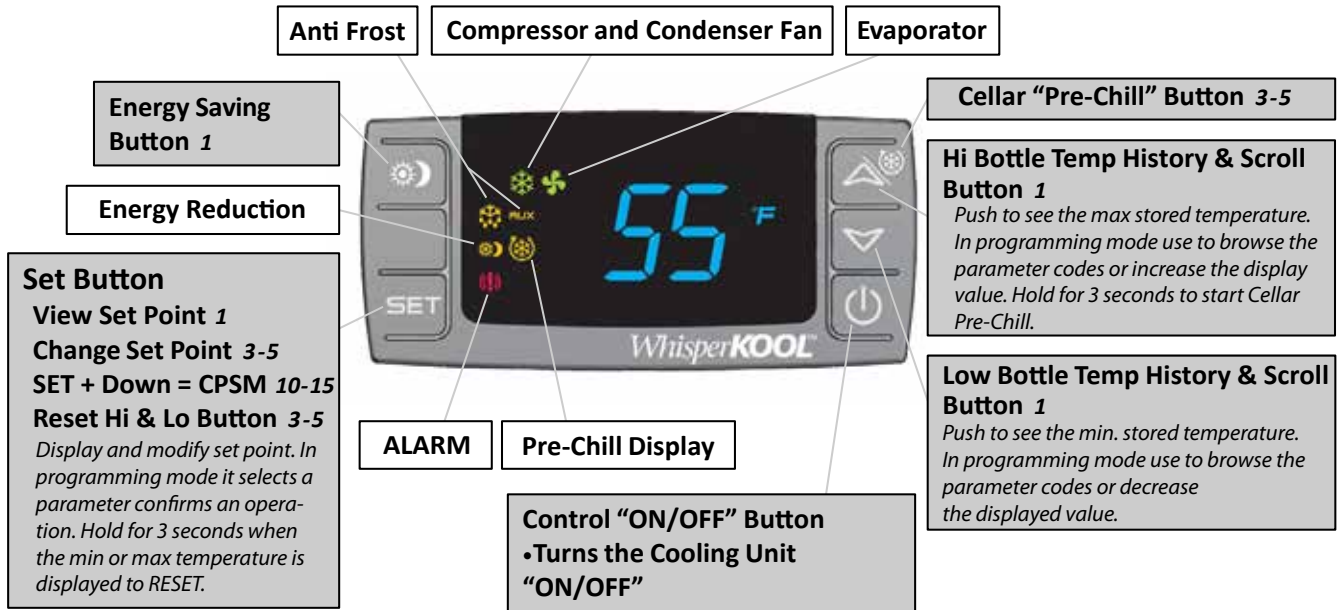

Specifications

Cellar Size*	350 cu. ft.
Dimensions	22"W x 10.25"H x 19"D
Weight	50 lbs
AMPS (starting/running)	17.5/3.5
dBA	Evaporator: 59 / Condenser: 53
Installation	Through-the-Wall, ideally above a doorway
Thermostat	Advanced Digital Control Display
Temp. Delta	30°F temperature differential
Warranty	2 year parts and labor / 5 year compressor

* Sizing the Unit to the Room

The specification chart will provide information on the units room size cooling capacity. There are circumstances in which a cellar design may require a larger unit due to some existing design restrictions. There are several factors such as glass, stone, concrete, etc. which will seem adequate but do not offer the insulation capacity required to maintain the optimum environment. We recommend purchasing a unit with a larger capacity to compensate for the design limitations. Under sized cooling units can lead to pre-mature failure and/or prevent the system from reaching the desired set temperature. As a result they are not covered under warranty.

INTRODUCTION

The Slimline is WhisperKOOL's quietest interior venting self contained unit available, designed to mount in a living area. Developed to fit into the often unused space between the cellar door and ceiling, giving the collector maximum storage capacity. The system is equipped with WhisperKOOL's Platinum Series controller utilizing Advanced System Protection Technology. This features a series of strategically placed monitoring probes, which ensure efficient performance and long cooling unit life. With efficiency in mind, the Slimline uses less power than most traditional units while having the ability to cool cellars up to 350 cubic feet.

Customer Service

Thank you for purchasing a WhisperKOOL Slimline cooling unit. We strive to provide the highest quality products and the best possible customer service. If you have any questions about your WhisperKOOL unit, please call us at 1(800) 343-9463.

Using the Manual

This User's Manual is intended to assist in the proper installation and maintenance of the WhisperKOOL Slimline cooling system. In order to ensure the longevity of your cooling unit, the equipment should be installed properly and have a proper care and maintenance schedule. Please read and review this manual carefully and keep it for future reference.

What Is the WhisperKOOL Slimline Cooling System?

The WhisperKOOL Slimline system is a specialized refrigeration unit designed for one purpose only: to maintain the optimal temperature and humidity levels conducive to the proper storage and aging of fine wines. It is a self-contained cooling unit designed to be used as a forced-air through-the-wall unit.

How Does the WhisperKOOL Slimline Work?

The WhisperKOOL Slimline cooling system is especially designed for the use and application to maintain optimal conditions for wine storage and aging. The system is specially designed for slow cooling, this greatly reduces the amount of humidity removed from the cellar.

Temperature Setting

The WhisperKOOL Slimline unit can be set at any temperature within the acceptable wine-aging range of 45°F to 67°F. It is designed to cool up to 30°F cooler than the ambient temperature of the space to which it is exhausting.

RECEIVING & INSPECTING THE UNIT

Receiving and Inspecting the Unit

- Lift only at the designated handhold locations on the shipping container or fully support the unit from underneath. A shipment may include one or more boxes containing accessories.
- Before opening the container, inspect the packaging for any obvious signs of damage or mishandling.
- Write any discrepancy or visual damage on the Bill of Lading before signing.
- Place the box containing the WhisperKOOL unit on a tabletop to prepare it for testing prior to installing.
- Sit upright for 24 hours.

Note: WhisperKOOL units are manufactured in the USA and tested prior to shipment.

Review the Packing Slip to Verify Contents

- Check the model number to ensure it is correct.
- Check that all factory options ordered are listed.

If any items listed on the packing slip do not match your order information, contact WhisperKOOL Customer Service immediately.

Check the Box for the following contents:

Mounting Brackets (2)

Accessory Kit One:

- WhisperKOOL Slimline Owner's Manual
- Bottle Temperature Probe
- 10' Power Cord

Accessory Kit Two:

- 1/2" Self-Tapping Screws (4)
- 1 3/4" Hex Head Screws (4)
- Drain Line tube with Brass Connector
- Insulation Foam Strips (4)

Please leave the WhisperKOOL unit in its original box until you are ready for installation, this will allow you to move the product safely without damaging it.

TIP: Save your box and all packaging materials. They provide the only safe means of transporting/shipping the unit.

QUICK START GUIDE

This guide is meant to serve as a quick reference for installation of the WhisperKOOL unit. The remainder of this Owner's Manual will provide more detailed information and instructions.

Upon receiving the WhisperKOOL unit:

1. **Inspect the unit before installation.** If damage is found, please contact your distributor or WhisperKOOL Customer Service at 1.800.343.9463 ext 799.
2. The unit should **remain in an upright position for 24 hours** prior to operation.
3. The WhisperKOOL unit **requires a dedicated 115 volt 20 amp circuit.** Use a surge protector with the WhisperKOOL unit. **Do not use a GFI** (Ground Fault Interrupter) line.
4. The unit is designed to gently cool down the temperature of the cellar over time by cycling cooler and cooler air throughout. **Test the unit prior to installation.**
6. It is **REQUIRED to install a drain line** to remove condensation from the unit.
7. The WhisperKOOL unit is intended **for use in properly designed and constructed wine cellars.** Hire a professional wine storage consultant with a valid contractor's license to build your wine cellar. Refer to the "How to Build a Wine Cellar" video available on the WhisperKOOL website at www.whisperkool.com.
8. Install the foam strips along the inside edge of the unit's flange to assure a proper seal against the wall.

Never try to open the WhisperKOOL unit, repair it yourself, or use a service company without WhisperKOOL's authorization. This will void your warranty.

If you encounter a problem with your WhisperKOOL unit, please refer to the Troubleshooting Guide. If you have any further questions, concerns, or need assistance, please contact WhisperKOOL Customer Service at 1.800.343.9463 ext. 799. Please be sure all testing has been completed prior to contacting Customer Service. Please have your results ready for your representative.

PREPARING THE WINE CELLAR

The performance and life of your WhisperKOOL unit is contingent upon the steps you take in preparing the wine cellar.

Note: Improperly preparing your enclosure or incorrectly installing your WhisperKOOL unit may cause unit failure, leaking of condensation, and other negative side effects.

IT IS HIGHLY RECOMMENDED THAT YOU OBTAIN THE ASSISTANCE OF A WINE STORAGE PROFESSIONAL.

Wine storage professionals work with licensed contractors, refrigeration technicians, and racking companies to build well-insulated, beautiful, and protective wine cellars. WhisperKOOL has put together some useful tips to assist in the installation process. Our recommendations are meant to act as a guide in the process of building a proper enclosure. Your intended location may have specific needs that we do not address.

How to Build a Wine Cellar Instructional Video

WhisperKOOL has a construction tutorial available on line at our website: www.whisperkool.com. This tutorial will walk you through the steps of constructing a properly built wine cellar and the installation of our WhisperKOOL product line.

Wall & Ceiling Framing

Build wine cellar walls using standard 2x4 or 2x6 construction methods and ceiling joists following the guidelines of local and state codes in your area. As a general rule, the thicker the walls and the higher the insulation value in your cellar, the better it will be at maintaining a consistent temperature.

Insulation

Insulation is **REQUIRED** with the use of the WhisperKOOL product. Standard fiberglass or rigid foam insulation is normally used in cellar construction or, in some cases, "blown-in" insulation is used. It is very important that all walls and ceilings are insulated to keep the cellar temperature as consistent as possible during the summer and winter months. The R-value, or quality of insulation, is determined by the rate at which heat passes through the insulation. The higher the R-value, the more resistant the insulation is to conducting heat. Using higher R-values in insulation will lower your operating costs and unit run time. (R-13 minimum, R-19 recommended, R-30 for ceiling and exterior walls.)

Vapor Barrier

A vapor barrier is **REQUIRED** to prevent the intrusion of water vapor so that the cellar can be kept at the correct temperature and humidity. 6 mm plastic sheeting (recommended) should be applied to the warm side of the cellar walls. The vapor barrier must also be applied to the outside walls and ceiling. If it is impossible to reach the outside, then the plastic must be applied from within the cellar. The most common method is to wrap the entire interior, leaving the plastic loose in the stud cavity so the insulation can be placed between each stud. All of the walls and ceiling must be wrapped in plastic for a complete vapor barrier.

In areas of high humidity, such as Southern and Gulf States, the vapor barrier will prevent infiltration of warm moist air. The moist air can cause mold to form, and standing water in drain pans promote microbial and fungal growth that cause unpleasant odors and indoor air quality problems. If mold is found, remove it immediately and sanitize that portion of the unit.

Mounting the Unit

The unit must be mounted within 18" of the top of the room in order to achieve sufficient cooling. As the room cools down, the warm air will rise to the ceiling. Mounting the WhisperKOOL high in the room will create a consistently cool environment by capturing the warm air and replacing it with cool air. Mounting the unit low in the room will result in a temperature variation in the room due to the unit's inability to draw warm air from the ceiling of the cellar to the unit itself, and cold air settling to the floor.

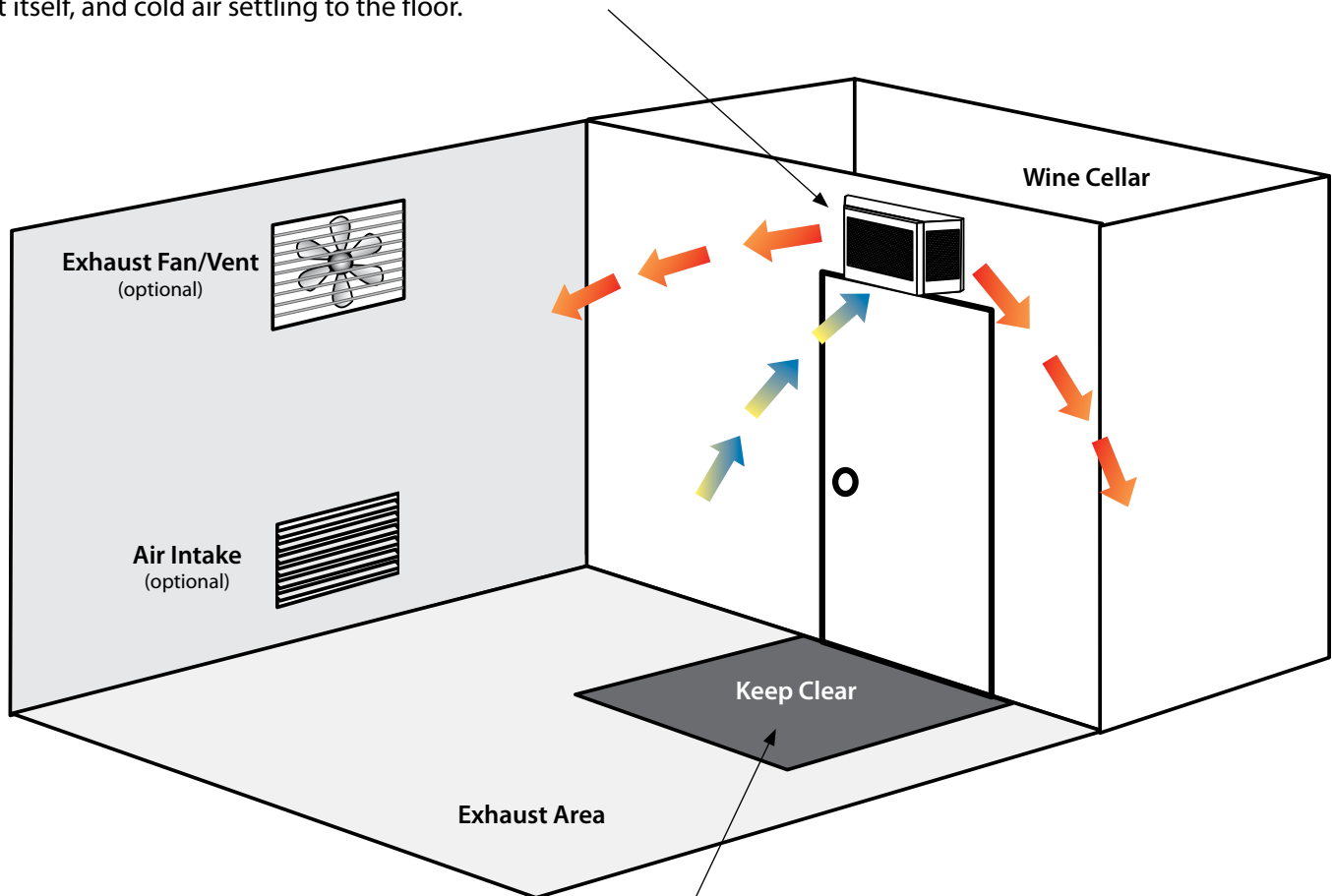

Unobstructed Airflow

Unobstructed airflow to and from the unit is critical for the unit's overall performance and life-span. A minimum three-foot clearance (five foot is ideal) area is crucial. The air the fans blow needs to circulate and either dissipate or absorb heat from the space, the more air to exchange the more efficient the system will operate.

Note: Avoid attempting to camouflage the unit. This will restrict airflow and thus the unit's ability to work efficiently.

Door and Door Seal

An exterior grade (1 3/4") door must be installed as a cellar door. It is very important that weather stripping is attached to all 4 sides of the doorjamb. A bottom "sweep" or threshold is also required. The door must have a very good seal to keep the cool cellar air from escaping out of the cellar. One of the most common problems with cooling units running continually is due to the door not sealing properly.

Ventilation

The necessity of dissipating heat away from the unit is critical to the unit's performance and cannot be overstated. As the unit operates and cools, a greater amount of heat is generated on the exhaust side of the unit. Adequate ventilation is required in order to dissipate heat away from the unit. If ventilation is inadequate, the exhaust will heat up the area or room and adversely affect the unit's ability to cool. In some cases, it may be advisable to install a vent fan to dissipate heat within the exhaust area on the backside of the unit. However, you must have a fresh air inlet as well.

Note: If you are unsure about having adequate ventilation in your install location, please contact us to assess your specific installation at support@whisperkool.com or 1.800.343.9463.

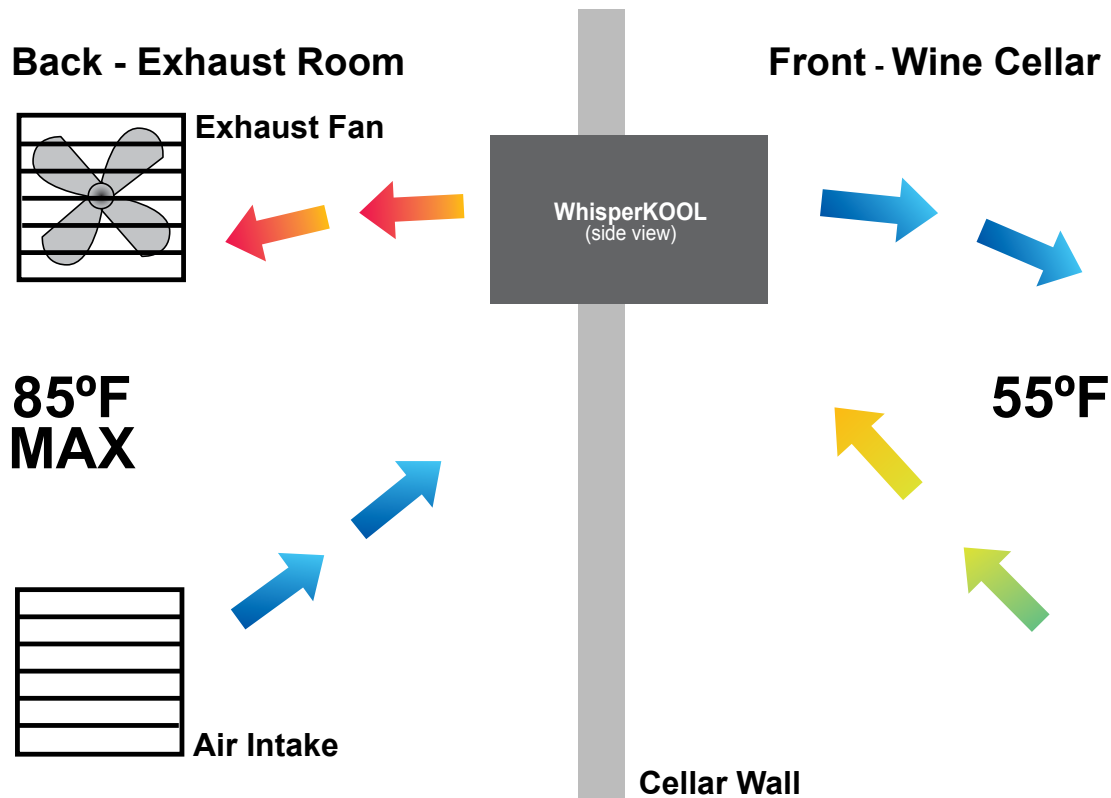

Ambient Temperature Factor

The cooling system has the ability to cool a wine cellar efficiently to 55°F as long as the ambient temperature of the area that it is exhausting to does not exceed 85°F. Therefore, you want to exhaust the unit in a room which will not exceed 85°F, preferably at 75°F, otherwise the unit will not have the capacity to keep the wine at a desirable 55°F.



Warning, allowing your system to operate in high ambient temperatures for extended periods of time will greatly decrease the life of your system and void your warranty.



Drain Line

All units come with a drain line for additional removal of excessive condensate. This is a back up system to the Condensate Evaporator. It is mandatory to install the drain line attachment. During operation, the cooling unit will strip excess water from the air in order to maintain the proper level of humidity within the cellar. The Condensate Evaporator will heat and dissipate the excess moisture through the rear of the unit. However in extreme humidity, additional condensate will be created. Conversely the high humidity air has less capacity to absorb additional moisture through the exhaust of the unit. Thus the drain line will prevent overflow and leaking by allowing for discharge of the additional condensate. WhisperKOOL carries a condensate pump kit, which allows the excess condensate to be pumped up to 20 ft. away from the unit.

PRE-INSTALLATION

Skill level: Moderate

Follow the local building codes and/or consult a license contractor

Electrical Needs

The WhisperKOOL System requires a dedicated 110-volt 20-amp circuit. The unit draws a large amount of amps at initial start up. By designating a dedicated circuit breaker, you will guarantee the unit has enough power to run effectively. Contact an electrician for assistance with the installation of this dedicated electrical circuit:

1. Match the electrical outlet to the plug provided on the WhisperKOOL unit.
2. Provide a dedicated circuit and wiring for the unit.

Electrical Outlet

The unit is equipped with a twelve foot power cord located on the evaporator side of the unit. Plug your WhisperKOOL unit into a surge protector or power conditioner. As with any sensitive electrical equipment, the WhisperKOOL electrical equipment may be damaged by power surges and spikes. Power surges and spikes are not covered in the WhisperKOOL warranty.

WE RECOMMEND THAT YOU DO NOT USE A GROUND FAULT INTERRUPTER (GFI) WITH THIS PRODUCT.

TEST THE UNIT PRIOR TO INSTALLATION

To prepare it for testing before installation in wall:

- Remove unit from box
- Place unit on tabletop
- Plug in unit to electrical outlet
- Plug in bottle sensor
- Turn on to test (Temperature differential should be 10°F across coils)
- Turn off after test
- Remove bottle sensor

Testing Unit - Place the WhisperKOOL system on a tabletop to prepare it for installation and testing. Plug system into a live electrical outlet and turn unit on. The system may take up to 10 to 15 minutes before running cool. Once the operation has been tested, turn the unit off, and unplug the unit from the electrical outlet.*

Units weigh 50 pounds and are cumbersome for one person to carry. We recommend that you get someone else to help you during the installation process. **NEVER LAY UNIT ON ITS SIDE.**

Note: If the system does not seem to be running cool after 15 minutes, please refer to the Troubleshooting Guide on Page 19.

PREPARING THE INSTALLATION LOCATION

Minimum Tools Needed

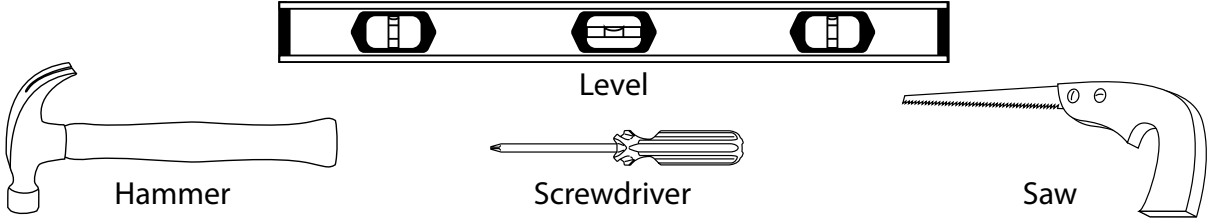

Note: The following installation examples are for reference only, door header construction and framing may vary. When not installing above a door, adequate framing inside of the wall is necessary. WhisperKOOL recommends consulting a licensed contractor for framing and construction needs.

STEP 1

Locate the desired installation location, using a level and a pencil mark a center line.

Mark the center line for your desired installation location, followed by laying out the hole for the unit.

*** Hole size: 22 1/2 inches by 10 3/4 inches**

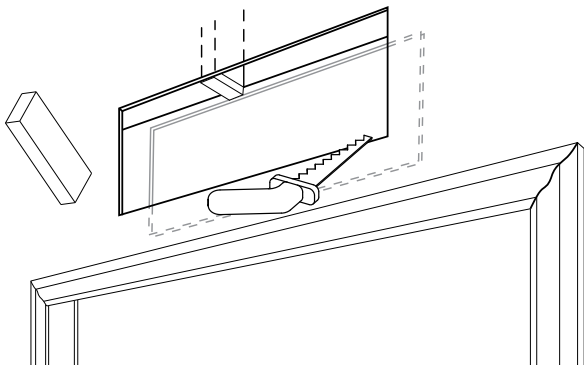
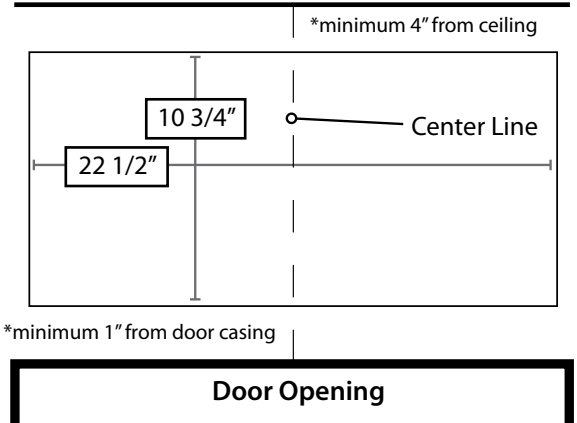

STEP 2

Cut out the drywall and studs for the unit opening.

Warning: Use caution not to cut through any electrical or plumbing.

STEP 3

In most cases framing will need to be added to provide adequate support for the unit and mounting bracket.

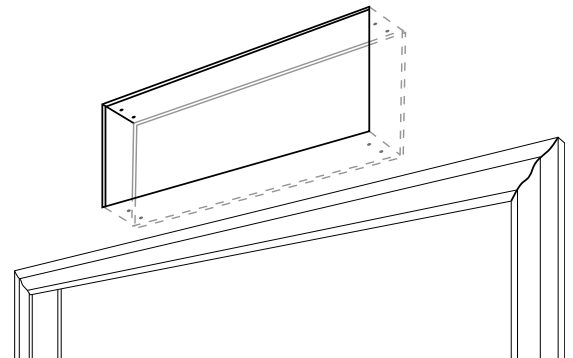

INSTALLATION

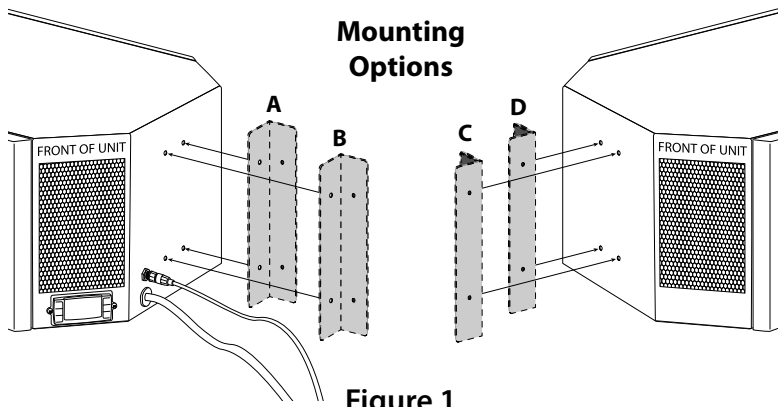

Figure 1

STEP 4

Determine which of the four bracket mounting options (displayed in Figure 1) will be the most suitable for the desired position of the Cooling Unit.

STEP 5

The Foam Tape needs to be placed on the Bracket surfaces that will be in direct contact with the wall.

If the desired option is (A) or (B) displayed in (Figure 1), the Foam Tape should be placed as shown in (Figure 2).

If the desired option is (C) or (D) displayed in (Figure 1), the Foam Tape should be placed as shown in (Figure 3).

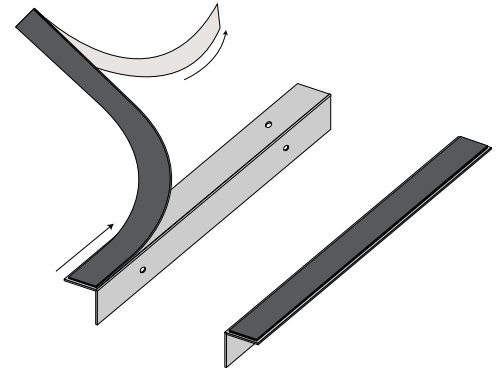

Figure 2

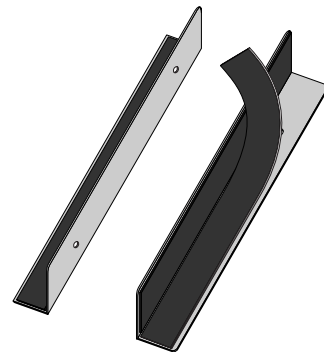
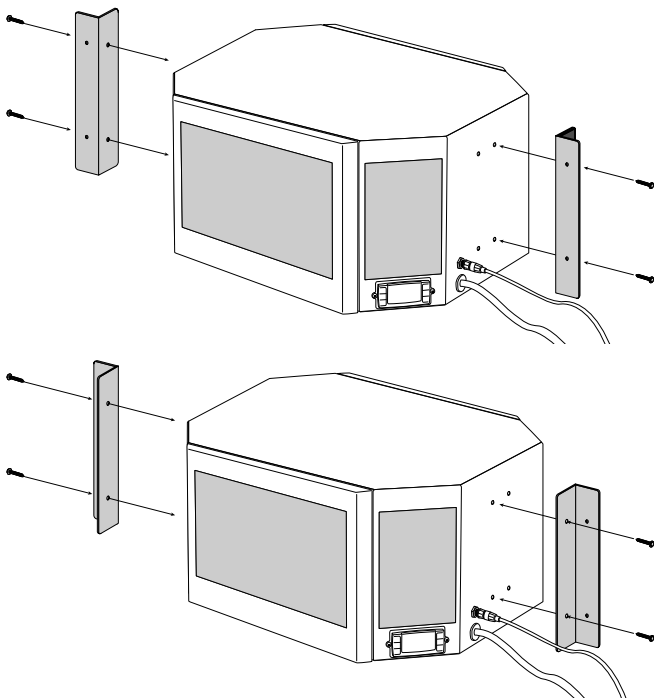

Figure 3



STEP 6

Secure each Bracket to its corresponding side of the Cooling Unit as displayed on your left hand side.

INSTALLATION

STEP 7

Slide the cooling unit in from the cellar side with the thermostat facing inside. Secure the 2 Brackets to the wall through the pre drilled holes. The screws should penetrate the studs and/or frame. Seal all cracks and gaps around the unit with an air-tight sealant or caulking to prevent air leakage.

Note: If you use decorative molding, it should be attached to the walls and never to the cooling unit.

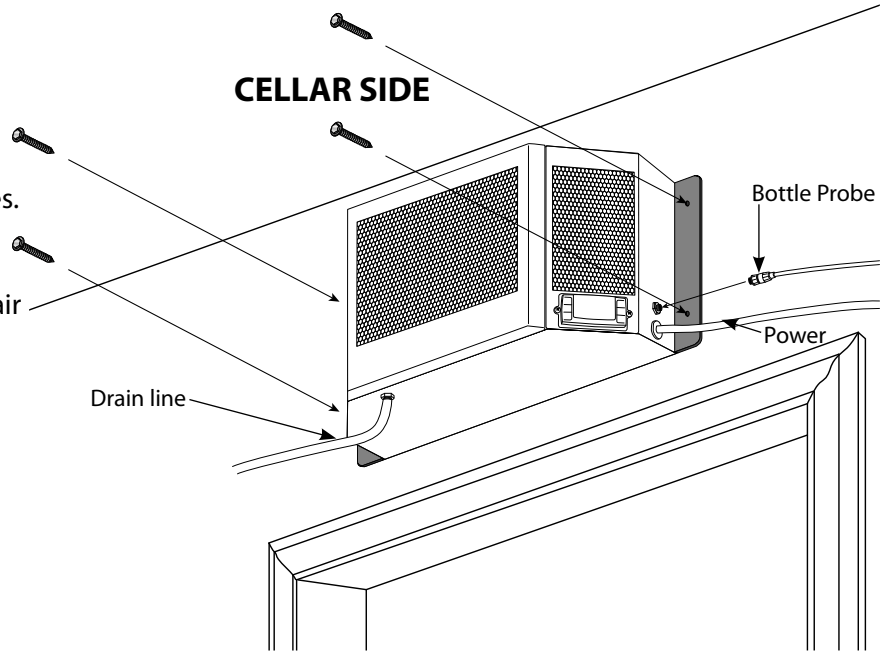

STEP 8

Attach the condensate drain line

The condensation drain line tube is used to remove excess condensation from the unit to a proper discharge location. It is important that the drain line tube is properly connected and used to prevent leakage and other problems associated with excess condensation.

Failure to use the condensation drain line tube will void the warranty on the unit.

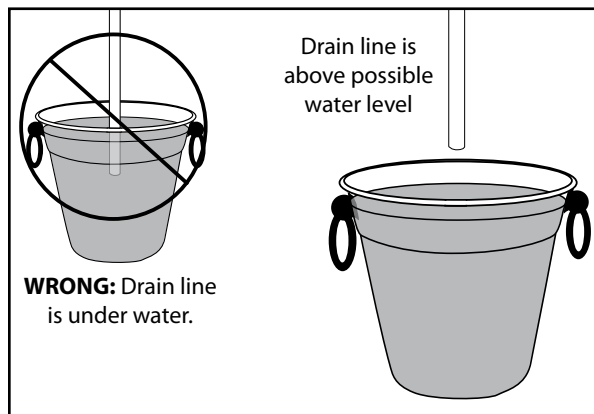

Note: To prevent mold from growing, allow the drain line to hang above the water line.



Failure to install the drain line voids warranty.



To prevent mold from growing, allow the drain line to hang above the water line.

STEP 9

If removed, install the grille's on both sides of the unit and plug in the power cord. The use of an extension cord is not recommended.

LIQUID MEASURING THERMOSTAT SYSTEM

The WhisperKOOL Series cooling units come equipped with a liquid temperature measuring thermostat. This incorporates the following advantages:

Self-Calibrating Bottle Probe

The bottle probe contains a sensor chip, which communicates back and forth with the thermostat. This results in a consistent temperature setting and accuracy.

1. Wine should be kept at a very precise, controlled temperature and humidity.
2. By measuring the liquid temperature rather than air, the unit will operate 75–80% of the time.

Setting Up The Bottle Probe:

1. Locate an empty wine bottle.
2. Fill $\frac{3}{4}$ full with room temperature tap water.
3. Place bottle probe securely into bottle as seen in Figure 1.
4. Place bottle with probe level and to the side of the unit in your wine cellar.
5. To assure a consistent temperature, place bottle probe approximately 3 feet away from the air output and not in the flow of the air.

It is recommended that the bottle be placed in a central location of your wine cellar. Avoid pulling too much on the probe cord. It may become disconnected resulting in limited functionality of the unit.

Note: The thermostat can be set between 50–67°F.

Remember: The CellarCool unit operates based on the temperature of the water. Do not be misled by thermostats reading air temperature. The air temperature in the cellar will be cooler than the liquid temperature of the wine while it is reaching optimum balanced temperature.

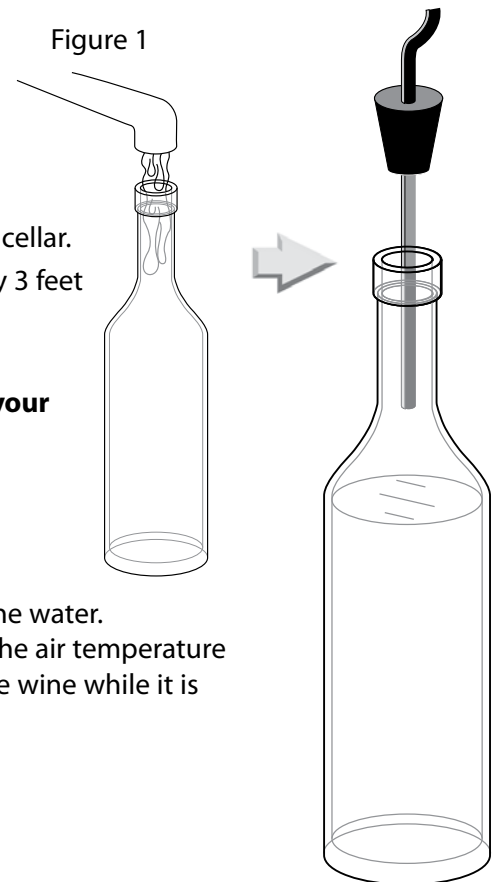

SYSTEM OPERATION

Initial Start-Up

When power is applied to the unit, the control will briefly display all symbols, and the Snowflake symbol will be displayed (if unit is calling for cooling). There may be a brief (up to 60 sec.) delay prior to the evaporator fan turning on. When the evaporator fan is activated the Fan symbol will display.

APST (Advance Product Safety Technology) is a temperature control feature for the evaporator fan that comes standard with all WhisperKOOL units. APST ensures that in the possible event of a cooling deficiency, the heat from the indoor fan will not raise the temperature of the wine cellar, which could otherwise have an adverse effect on the wine-aging process.

Set Point

The set point is set from the factory (WhisperKool) at 55°F. It can be adjusted by the customer between 45–67°F in one degree increments.

Cooling Operation

The FON function is an adjustable feature which allows the customer the convenience of reintroducing some of the humidity removed by the fan coil during the cooling process. The FON Function controls the evaporator fan operation once the set point has been reached. When the bottle probe has reached the set point (all units are shipped with the set point of 55°F and a differential of 1°), the compressor and the condenser fan will turn off, but the indoor fan will continue to run for about 5 minutes to re-introduce any moisture from the evaporator coil. All units come with this feature turned off. If low humidity is a problem an increase in this setting will raise the humidity level. The FON function is one of the many Customer Preference Selection features that allow the customer the ability to fine-tune the controls.

Humidity Features

The Fon parameter can be increased to allow the evaporator and condenser fans to run for a longer period of time after the compressor turns off, allowing more moisture to be re-introduced into the wine cellar.

Anti-Short Cycle

The Anti-Short Cycle ensures that the compressor will remain off for a period of three minutes after the unit has reached the set point to allow the pressure in the refrigeration unit to equalize prior to starting the compressor.

Anti-Frost Cycle (defrost)

When the evaporator probe senses a temperature of 26°F for five minutes, the unit will go into Anti-Frost mode. This will shut down the compressor and allow the evaporator and condenser fans to run to evaporate any frost accumulation on the coil. The compressor will remain off until the evaporator coil reaches 40°F, or for a maximum of ten minutes. The unit will then return to normal operation.

Bottle Probe Failure Protection

In the event that a bottle probe should fail, the APST (Advance Product Safety Technology) will automatically transition the refrigeration compressor cycles to a pre-determined time series (based on detailed laboratory testing), which will ensure that the product is kept within the safe range.

Display

The bottle probe temperature is displayed by default. “Def” is displayed during Anti-Frost. The air sensing probe and evaporator probe temperatures can be accessed by pushing the SET button and scrolling through “PB1” (bottle probe), and “PB2” (evaporator probe).

Safety Features

Once the compressor relay is de-energized the controller must wait five minutes before re-energizing the relay. This prevents the compressor from repeatedly turning off and on. If the unit is calling for cooling during this time, the compressor symbol will blink, indicating that cooling is needed but the control is waiting for the Anti-Short cycle delay.







In the event of a faulty bottle probe, the compressor will cycle off for 10 minutes and on for 40 minutes. “E1” will be displayed on the screen.



Alarms

See “Alarm Codes” in Controller Function chart.

CONTROL FUNCTIONS



Button/Symbol	Normal Functions
<p>ON/OFF</p> 	<ul style="list-style-type: none"> The ON/OFF button allows the customer the convenience of turning the refrigeration system ON or OFF, from the control panel. This feature does not disconnect power from the unit. In order for the power to be shut off from the unit, the power cord must be unplugged from the wall receptacle. Press the ON/OFF button once for button application.
<p>Up and Down Arrows</p>  	<ul style="list-style-type: none"> Use these buttons to scroll up or down the CPSM (Customer Preference Selection Mode) menu. Displays the Highest and Lowest temperature sensed by the Bottle Probe. This feature allows the customer instant access to the recorded data applicable to the Bottle Probe Temperatures, it can be easily reset to reflect current temperatures. <ol style="list-style-type: none"> Press the "UP" arrow, or the "Down" arrow once, and the Highest or Lowest Temperature (Hi/Lo) sensed by the Bottle Probe, will be displayed. To reset the Hi/Lo, press and hold the "Set" button when the Hi/Lo value is displayed on the Digital Display, continue to hold the "Set" button until "rst" appears on the digital display and then blinks. This will erase the past recorded "Temperature Data History" and start recording, from the current time and temperature, forward. Temperatures displayed would reflect Bottle Probe Temperatures from that point in time, and beyond. The Hi/Lo feature should be reset at initial "Start-Up" and after the Cellar or Cabinet has obtained normal operating temperatures, which is generally 55°F.
<p>Cellar PreChill (CPC)</p>  	<p>The CPC Feature is activated by pressing the Up button for 3-5 seconds, and the CPC logo will be displayed on the digital display. The CPC feature can be terminated by pressing the Up button for 3-5 seconds, or the feature will self terminate after 6 hrs.</p> <ol style="list-style-type: none"> The (CPC) Feature may be used to Pre-Chill the Cellar prior to loading it with Warm Product. The feature will shift the Set Point down to a lower setting of 52°F, for the next 6 hours. After the 6 hour time period, the Set Point will automatically return to the original Set Point. The CPC feature can be conveniently adjusted to the customer's specific needs, by accessing the "Customer Preference Select Mode" (CPSM). See Customer Preference Select Mode Instructions.
<p>Energy Reduction (ER)</p>  	<ol style="list-style-type: none"> The ER feature is activated by pressing the ER button one time, and the ER logo will appear on the digital display. The purpose of the ER feature is to reduce energy cost, by shifting the Set Point up by 4 degrees, which will allow the cooling system to run for shorter periods of time, resulting in a reduction in energy cost. The ER feature allows for Energy Savings at any time - During periods of high ambient temperatures, vacations or business travel. To deactivate the ER feature, press the ER button one time, and the ER logo will turn off. The ER feature can be conveniently adjusted specific need by accessing the "Customer Preference Select Mode" (CPSM). See CPSM Instructions on the next page.

<p style="text-align: center;">SET</p>	<p>SET</p> <ol style="list-style-type: none"> 1. Press the "Set" button once and it will display the Set Point. After approximately 5 seconds, the display will return to normal operation and display the Bottle Probe temperature. 2. Standard Controller - Press and hold the "Set" button for 3-5 seconds until the set point is displayed and the °F symbol starts blinking. Next press the "UP or Down" arrows to change the Set Point. Next press the "Set" button once and the Set Point numbers and the °F on the display will blink to confirm the new Set Point setting. 3. Press and hold the "Set" button during the display of the Hi/Low "Temperature Data History" (hold button unit "rst" blinks on display), and it will erase the past recorded data file and start recording, from the current time and temperature. 4. Press the "Set" and the "Down Arrow" buttons simultaneously, for 10-15 seconds, and you will access the "Customer Preference Selection Mode" (CPSM). The CPSM allows the customer to "Fine Tune" the Control Operating System to their applicable choice.
<p style="text-align: center;">Anti-Frost</p>  <p style="text-align: center;">AUX</p>	<p>The Anti-Frost Cycle is automatically activated when the evaporator temp has reached a low temp of 26° and has sustained that temp for a period of five minutes. During this cycle the compressor and condenser fans will turn off and the evaporator fans will continue to run. Once the temperature of the evaporator gets back up to 40° the cycle will deactivate and the system will revert back to normal operating conditions.</p> <p>At the beginning of the cycle the AUX symbol will be illuminated and the  symbol is illuminated during the anti-frost cycle.</p>
<p style="text-align: center;">Alarm</p> 	<p>The Alarm symbol is shown when the system encounters an issue that needs attention, the displayed alarm codes are explained below.</p>

Alarm Codes

Message	Cause	Solution
"P1"	Bottle Probe is Unplugged	Attach Bottle Probe to Unit
	Faulty Bottle Probe Connection	<ol style="list-style-type: none"> 1. Check Bottle Probe attachment at circular connector 2. Check Bottle Probe connection at green terminal block on back of controller
	Defective Bottle Probe	Replace the Bottle Probe
"P2"	Faulty Evaporator Probe Connection	Check Evaporator Probe connection at green terminal block on back of controller
	Defective Evaporator Probe	Replace the Evaporator Probe
"HA"	Defective Bottle Probe	Replace the Bottle Probe
"LA"	The Bottle Probe is sensing a temperature of 4° below the set point	Allow the room to warm up which will increase the temperature of the wine
	Defective Bottle Probe	Replace the Bottle Probe
"POF"	The keypad is locked	Hold "Up" and "Down" buttons for 3 to 5 seconds to disable, "PON" should appear

CPSM Mode	<p>Press the "Set" and the "Down Arrow" buttons simultaneously, for 10-15 seconds, and you will access the "Customer Preference Selection Mode" (CPSM). The CPSM allows the customer to "Fine Tune" the Control Operating System to their applicable choice.</p> <p>The following CPSM options are available for adjustment:</p> <p>Fon – Humidity Management Enhancement: This parameter is normally set at 0, which should provide adequate relative humidity for the cellar.</p> <ul style="list-style-type: none"> • An increase in this parameter will increase the Humidity Enhancement (%RH), and a decrease in the parameter will decrease Humidity Enhancement (%RH). • Adjustments should be made in increments of 5, with a maximum of 15, and a minimum of 0. • After any adjustment to Humidity Enhancement, you should wait a minimum of three days before making any additional adjustments. This will allow the cellar sufficient time to acclimate to the new setting. <p>Fof - Humidity Management Enhancement: This parameter is normally set at 15. This parameter should not be adjusted, as it simply provides an OFF cycle time for the fan, during the compressor OFF cycle. However, the parameter is located within the CPSM as a convenience to the customer, should it need to be adjusted.</p> <p>CCS – Cellar Pre-Chill Set Point: This parameter is set at 52°F, but can be adjusted to a set point between 50°F- 67°F.</p> <p>CCT - Cellar Pre-Chill Duration: This parameter is set to 6 hours, but can be changed between 0-23.5 hours.</p> <p>Con/Cof – Compressor On time (Con) and Off time (Cof) with a Probe 1 failure/Alarm. These parameters are set at Con 40 min/Cof 10 min. In the event that there is a Probe 1 failure/Alarm, the compressor/refrigeration system automatically starts a predetermined ON/OFF cycle, which is controlled by the Con and the Cof parameters. The customer can adjust these parameters to maintain the desired Bottle temperature.</p> <p>Hes – Differential for Energy Reduction – This parameter is set at 4° above the set point, during the Energy Reduction mode. A decrease in this setting will decrease the set point, and an increase in this feature will increase the set point.</p>
-----------	--

MAINTENANCE SCHEDULE

It is the user's responsibility to remove any accumulated dust, lint, or other debris from the front and rear intake grilles. This will restrict the airflow and may affect the unit's ability to function properly. Periodically cleaning the unit's vents will help assure maximum cooling efficiency. The drain tube must also be checked and kept clean and free of debris and mold to maintain proper performance.

Monthly	<ol style="list-style-type: none">1. Check for unusual noise or vibration2. Check the drainline to see if it is above the waterline if draining into a vessel.
Quarterly	<ol style="list-style-type: none">1. Clean front and rear intake grilles.
Annually	<ol style="list-style-type: none">1. Use a vacuum with brush attachment to clean grilles.2. Inspect for corrosion.3. Check wiring connections and integrity of cords.4. Pour a 50/50 bleach solution into the drainline every spring.

TROUBLESHOOTING GUIDE

Unit has ice forming on the evaporator	
Possible Cause	Solution
Evaporator coil is dirty.	Clean coil with a vacuum. If coil is very dirty, use a small hand spray with a small amount of liquid dish washer detergent. Spray coil, let set for 5 min, then flush with fresh water.
There is something blocking the supply and or return air	Remove blockage
One or both evaporator fans are not turning on.	Call a service tech to troubleshoot
The temperature of the room, the unit is exhausting to, has dropped below 50°	Raise the temperature of the exhaust room
The unit has not gone through its anti-frost sequence yet.	Check for ice in the depth of the coil. Melt with blow drier until coil is warm to the touch. Soak up water with a towel.
If unit continues to ice.	Observe ice formation pattern. If only part way up the coil face, unit could be low on refrigerant. If so, call Customer Service at 800-343-9463
Unit does not run/power up	
Possible Cause	Solution
Unit is not plugged in	Make sure the unit is plugged into an outlet
Power switch not on	Turn unit on by pressing the power button on the control
Line voltage is incorrect rating for unit	Check line voltage to make sure there is 110v/120v
Room at set point	Lower set point
Thermostat not calling for cooling	Lower set point
Faulty thermostat or wiring	Call Customer Service at 800-343-9463
Cellar Temperature is too Warm	
Possible Cause	Solution
The temperature of the room unit is exhausting to has exceeded 85°	Lower the temperature of the exhaust room.
The unit is undersized for the room.	Order correct size unit
There is something blocking the supply and/or return air, on evaporator or condenser side of the unit	Remove air flow obstruction
Unit is mounted too low in the cellar	Re-Locate unit so the distance from the ceiling and top of the unit is no more than 18"
One or more of the fans are not turning on.	Call Customer Service at 800-343-9463
Compressor is not turning on.	Call Customer Service at 800-343-9463
Compressor keeps cycling on overload	Make sure all fans are working and there are no airflow obstruction.
Poor seal around door.	Make sure there are no air gaps around the door. If door seal is damaged, replace it.
Controller set too high	Lower the set point.
Evaporator coil is frosted or iced up	Observe ice formation pattern. If only part way up the coil face, unit could be low on refrigerant. If so, call Customer Service at 855-235-5271

TROUBLESHOOTING GUIDE

Unit leaks water	
Possible Cause	Solution
Unit is not level	Unit should be level in wall to prevent leaking
Drain line clogged or kinked	Check drain line to make sure water can flow freely.
Drain is clogged preventing water from escaping	Disconnect drain and clear out
Drain line does not have a downward slope	Fix Drain line so there is a downward slope from the unit to the drain.
Coil is iced causing drain pan ice and water overflowing	Melt ice with blow drier. Soak up with a towel
Unit runs but does not cool	
Possible Cause	Solution
Lack of air flow	Make sure fan is unobstructed; clean evaporator if necessary
Compressor not running	Call Customer Service at 800-343-9463
Unit undersized	Call Customer Service at 800-343-9463
Fans run but compressor does not.	Compressor may have overheated. Shut unit off for 1 hour to allow compressor to cool. Turn back on and check for cooler air flow out. If compressor runs, check for and clean condenser coil as possible cause of compressor overheating. If problem repeats, call customer service.
Evaporator fan runs but compressor does not	
Possible Cause	Solution
Compressor and/or starting components faulty	Call Customer Service at 800-343-9463
Fans run but compressor does not.	Compressor may have overheated. Shut unit off for 1 hour to allow compressor to cool. Turn back on and check for cooler air flow out. If compressor runs, check for and clean condenser coil as possible cause of compressor overheating. If problem repeats, call customer service.
Compressor runs; evaporator fan does not	
Possible Cause	Solution
Faulty fan motor	Call Customer Service at 800-343-9463
Faulty fan relay	Call Customer Service at 800-343-9463
Compressor short cycles	
Possible Cause	Solution
Evaporator fans blow on bottle probe	Move bottle probe to a more central location.
Unit low on refrigerant charge	Call Customer Service at 800-343-9463
Condensing fan motor/capacitor faulty	Call Customer Service at 800-343-9463
Compressor and /or starting components faulty	Call Customer Service at 800-343-9463
Humidity in cellar too high	
Possible Cause	Solution
Cellar vapor barrier not sufficient	Install proper vapor barrier

TECHNICAL ASSISTANCE

WhisperKOOL Customer Service is available Monday through Friday from 6:00 a.m. to 4:00 p.m. Pacific Time.

The customer service representative will be able to assist you with your questions and warranty information more effectively if you provide them with the following:

- The model and serial number of your WhisperKOOL Series Unit.
- Location of unit and installation details, such as ventilation, ducting, construction of your wine cellar, and room size.

Contact WhisperKOOL Customer Service

1738 E. Alpine Avenue

Stockton, CA 95205

www.whisperkool.com

Email: support@whisperkool.com

Phone: (209) 466-9463

US Toll Free (800) 343-9463

Fax (209) 466-4606

ACCESSORIES FOR COOLING UNITS

WhisperKOOL offers accessories to enhance and customize your Slimline wine cooling unit.

ThruWall Room to Room Fan

The ThruWall™ Room to Room Fan balances temperatures in adjoining rooms by transferring warm air out of exhaust room quietly and efficiently. Simple to install in any frame wall from 3-1/2" to 6-3/4" thick. A high quality Thermally Protected motor with balanced fan blade moves up to 200 CFM. Move heated or cooled air between rooms.

Condensate Pump Kit

The condensate pump kit is designed as an automatic condensate removal pump for water dripping out of our cooling units' drain line. The pump is controlled by a float/switch mechanism that turns the pump on when approximately 2-1/4" of water collects in the tank, and automatically switches off when the tank drains to approximately 1-1/4". The condensate pump kit allows the excess condensate to be pumped up to 20ft away from the unit.

Accessories can be purchase at www.whisperkool.com

**WhisperKOOL Product Terms and Conditions
Including Product Limited Warranty And Product Installation Requirements
For WhisperKOOL Extreme Series**

ATTENTION: PLEASE READ THESE TERMS OF USE CAREFULLY BEFORE INSTALLING YOUR WHISPERKOOL COOLING SYSTEM. INSTALLING YOUR WHISPERKOOL COOLING SYSTEM INDICATES THAT YOU ACCEPT AND AGREE TO EACH OF THE TERMS AND CONDITIONS SET FORTH HEREIN ("TERMS OF USE"). IF YOU DO NOT ACCEPT THESE TERMS OF USE, YOU RISK VOIDING YOUR WARRANTY AND ASSUMING ADDITIONAL REPAIR AND REPLACEMENT COSTS.

1. Purchase of a WhisperKOOL Cooling System assumes that the Purchaser ("End User") fully accepts and agrees to the Terms and Conditions set forth in this document. The Terms and Conditions of Sale and Owner's Manual are shipped with each unit and, if another copy is needed, replacement copies can be downloaded from the company website (whisperkool.com) or by contacting WhisperKOOL directly for a new copy. WhisperKOOL reserves the right, in its sole discretion, to change its Terms and Conditions at any time, for any reason, without notice.

2. WhisperKOOL Product Limited Warranty:

A. Two (2) Year Limited Warranty: For the period of TWO (2) YEARS (the "Limited Warranty Period") from the date of original sale of a Product by WhisperKOOL, if a WhisperKOOL Product is found to be defective in material or workmanship after undergoing WhisperKOOL's Customer Service troubleshooting, then, subject to the WhisperKOOL Product Limited Warranty Limitations and Exclusions as well as the other Terms and Conditions stated herein, WhisperKOOL will do the following, as appropriate, for the end user ("End User") who has installed and is actually using the Product, with regard to LABOR, PARTS and FREIGHT:

1. **LABOR** — Repair or replace (at WhisperKOOL's sole option) the Product to the End User; and
2. **PARTS** — Supply to the End User, new or rebuilt replacement parts for the Product in exchange for the return of defective parts; and
3. **FREIGHT** — Cover normal ground freight charges for parts, and, in the event the Product is not repairable in the field, cover normal ground freight charges (within the continental United States) for the repair or replacement of the Product.

B. Five (5) Year Compressor Limited Warranty: WhisperKOOL Products' compressor only will be covered for five (5) years from date of purchase. Labor and freight of the compressor is the End Users responsibility.

C. Product Warranty Limitations and Exclusions:

1. This limited warranty does not cover cosmetic damage caused during installation, damage due to acts of God, commercial use, accident, misuse, abuse, negligence, or modification to any part of the Product. Delivery and installation of the Product, any additional parts required, as well as removal of the Product if warranty work is required, are all at the sole cost, risk and obligation of the End User.
2. This limited warranty does not cover damage due to improper installation or operation or lack of proper maintenance of the Product, connection of the Product to improper voltage supply, or attempted repair of the Product by anyone other than a technician approved by WhisperKOOL to service the Product.
3. This limited warranty does not cover any Product sold "AS IS" or "WITH ALL FAULTS."
4. Product that has been replaced during warranty period does not extend the warranty period past the original date of purchase.
5. (5) This limited warranty is valid only in the continental United States. Sales elsewhere are excluded from this warranty.
6. Proof of purchase of the Product in the form of a bill of sale, receipted invoice or serial number, which is evidence that the Product is within the Limited Warranty Period, must be presented by the End User to WhisperKOOL in order to obtain limited warranty service.
7. This limited warranty is void if the factory applied serial number has been altered or removed from the Product.

8. This limited warranty is voided if installed in an enclosure of insufficient design that does not follow the Product installation requirements stated herein and in the Owner's Manual.
9. Removing the rivets from the Product's unit housing without prior authorization from WhisperKOOL voids this limited warranty.
10. The End User must first contact WhisperKOOL Customer Service by telephone (at 1-800-343-9463) prior to attempting service on any Product still under the limited warranty; else the limited warranty is voided.
11. This limited warranty does not cover Product being concealed by, but not limited to; vegetation, fabric, shelving, mud, snow, or dirt. Product must not be painted or limited warranty will be void.
12. This limited warranty does not cover exposure to corroding environments such as, but not limited to; petroleum and gasoline products, cleaning solvents, caustic pool chemicals, and marine air.
13. This limited warranty does not cover any cause not relating to Product defect.
14. THE REPAIR OR REPLACEMENT OF THE PRODUCT AS PROVIDED UNDER THIS LIMITED WARRANTY IS THE EXCLUSIVE REMEDY OF YOU, THE END USER, AS WELL AS ANYONE ELSE IN THE CHAIN OF TITLE OF THE PRODUCT, DOES NOT START A NEW LIMITED WARRANTY TIME PERIOD, AND IS IN LIEU OF ALL OTHER WARRANTIES (EXPRESS OR IMPLIED) WITH REGARD TO THE PRODUCT. IN NO EVENT SHALL WHISPERKOOL BE LIABLE FOR INCIDENTAL, CONSEQUENTIAL, SPECIAL OR CONTINGENT DAMAGES FOR BREACH OF ANY EXPRESS OR IMPLIED WARRANTY ON THIS PRODUCT. THE IMPLIED WARRANTIES OF MERCHANTABILITY AND FITNESS FOR A PARTICULAR PURPOSE ARE HEREBY EXPRESSLY DISCLAIMED. Some states do not allow the exclusion or limitation of incidental or consequential damages, or allow limitations on how long an implied warranty lasts, so the above limitations or exclusions may not apply to you. This limited warranty gives you specific legal rights, and you may have other rights, which vary from state to state.
15. Failure of the End User to comply with all of the Product Installation Requirements, Maintenance Requirements and End User Requirements may, at WhisperKOOL's sole discretion, void this limited warranty.
16. No one has any authority to add to or vary the limited warranty on this Product.

3. Product Installation Requirements:

- A. Prior to installing a WhisperKOOL Product, the End User must read the WhisperKOOL Owner's Manual and thereafter the End User must follow the required installation, use and maintenance procedures set forth by WhisperKOOL in WhisperKOOL's Owner's Manual. The Owner's Manual is shipped with each Product and if another copy is needed, replacement copies can be downloaded from WhisperKOOL's website (www.whisperkool.com) or by contacting WhisperKOOL directly for a new copy of the Owner's Manual.
- B. It is highly recommended that the End User obtain the assistance of a wine storage professional.
- C. Failing to address all of the variables associated with proper installation will cause the Product to operate incorrectly and limit both the Product's ability to cool and the longevity of the Product itself.
- D. The End User is responsible for all risks and costs of installation of the Product, including but not limited to all labor costs as well as cost of any additional parts required for the proper and complete installation of the Product. The End User is responsible for all risks and costs of removing the Product if limited warranty work is required.
- E. The Product cannot operate at its optimum capacity if airflow is constricted by ducting or venting the exhaust side of the Product into a location with inadequate ventilation.

4. Maintenance Requirements

It is the End User's responsibility to clean off any accumulated dust, lint, or other debris from the front and rear intake grills. Failure to do this on a regular basis will restrict the airflow and may affect the Product's ability to function properly. Periodically cleaning the Product's vents will help assure maximum cooling efficiency. The drain line tube must also be checked and kept clean and free of debris and mold to maintain proper performance.

Mold is a natural living organism in the environment. It exists in the air in the form of microscopic spores that move in and out of buildings through doors, windows, vents, HVAC systems and anywhere else that air enters. Once it is discovered, mold must be addressed quickly and appropriately. Delayed or improper treatment of mold issues can result in costly and reoccurring repairs. If the End User suspects a mold problem, it is always best to hire a qualified and experienced mold remediation specialist.

5. Additional End User Costs And Responsibilities

The following items are not covered under any warranty and are the sole responsibility of the End User:

- A. End Users should satisfy themselves that the Product they are purchasing is suitable for their particular needs and requirements, and thus no responsibility will be placed with WhisperKOOL for the End User's decisions in this regard.
- B. It is the End User's responsibility to secure safe haven/storage for ANY AND ALL items that are being kept and stored in the End User's wine cellar, including any Product. WhisperKOOL takes no responsibility for the safety and preservation of the aforementioned items in the event that the environment becomes unsuitable to maintain a proper storage environment.
- C. End User is responsible for initial installation costs, including, but not limited to, labor costs and the cost of any additional parts necessary to complete the installation.
- D. End User is responsible for all costs incurred for the installation and/or removal of the Product, or any part thereof, unless such cost has been agreed by WhisperKOOL to be a warranty repair prior to the work being performed.

6. Sales and Use Tax

WhisperKOOL only collects California sales tax for orders shipped within the State of California. WhisperKOOL does not collect sales tax for orders shipped to other states. However, the Purchaser and the End User may be liable to the taxing authority in their state for sales tax and/or use tax on the Product. The Purchaser and the End User should each check with their state's taxing authority for sales and use tax regulations.

7. Customer Service and Troubleshooting

WhisperKOOL's Customer Service department is available to answer any questions or inquiries for End Users regarding a WhisperKOOL Product, as well as to assist in performing basic troubleshooting, Monday through Friday, from 6:00 a.m. to 4:00 p.m. (PST), at 1-800-343-9463. WhisperKOOL Corporation is located at 1738 East Alpine Avenue, Stockton, California 95205.

8. Miscellaneous Terms and Conditions

- A. Return Policy: All return inquiries must be made within thirty (30) calendar days of the original purchase of a Product and are subject to a twenty five percent (25%) restocking fee. Shipping costs are not refundable and the Purchaser is responsible for all return shipping costs (including customs fees and duties, if applicable).
- B. Security Interest: WhisperKOOL retains a security interest in each Product until payment in full.
- C. Construction and Severability: Every provision of these Terms and Conditions shall be construed, to the extent possible, so as to be valid and enforceable. If any provision of these Terms and Conditions is held by a court of competent jurisdiction to be invalid, illegal or otherwise unenforceable, such provision will, to the extent so held, be deemed severed from the contract of sale between Purchaser and WhisperKOOL, and all of the other non-severed provisions will remain in full force and effect.
- D. Governing Law/Choice of Forum: The laws of the State of California (without regard for conflicts of law) shall govern the construction and enforcement of the these Terms and Conditions of Sale (Sections 1 through 9 inclusive, including Product Limited Warranty And Product Installation Requirements), and further these Terms and Conditions of Sale shall be interpreted as though drafted jointly by WhisperKOOL and Purchaser. Any dispute will be resolved by the courts in and for the County of San Joaquin, State of California, and all parties, WhisperKOOL, Purchaser and End User, hereby irrevocably submit to the personal jurisdiction of such courts for that purpose. No waiver by WhisperKOOL of any breach or default of the contract of sale (including these Terms and Conditions of Sale) concerning a Product will be deemed to be a waiver of any preceding or subsequent breach or default.
- E. Correction of Errors and Inaccuracies: These Terms and Conditions may contain typographical errors or other errors or inaccuracies. WhisperKOOL reserves the right to correct any errors, inaccuracies or omissions, and to change or update these Terms and Conditions, at any time without prior notice.

9. Questions, Additional Information And Technical Assistance

A. Questions: If you have any questions regarding these Terms and Conditions or wish to obtain additional information, contact us via phone at 1-800-343-9463 or please send a letter via U.S. Mail to:

Customer Service
WhisperKOOL Corporation
1738 E Alpine Ave
Stockton, CA 95205

E-mail: support@whisperkool.com
Web: www.whisperkool.com

B. Technical Assistance: WhisperKOOL Customer Service is available Monday through Friday from 6:00 a.m. to 4:00 p.m. (PST). The Customer Service representative will be able to assist you with your questions and warranty information more effectively if you provide them with the following:

1. The model and serial number of your WhisperKOOL UNIT.
2. The location of the system and installation details, such as ventilation, construction of your wine cellar, and room size.

Model _____ **Serial Number** _____

Installed by _____ **Date** _____

NOTES

*Whisper***KOOL™**

WhisperKOOL
1738 E. Alpine Ave
Stockton, CA 95205
1(800) 343-9463
www.whisperkool.com