

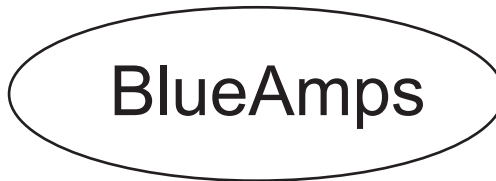

&



Users MANUAL

Camplifier 360

2 x180W stereo add on power amplifier module

for the Kemper Profiling Amplifier

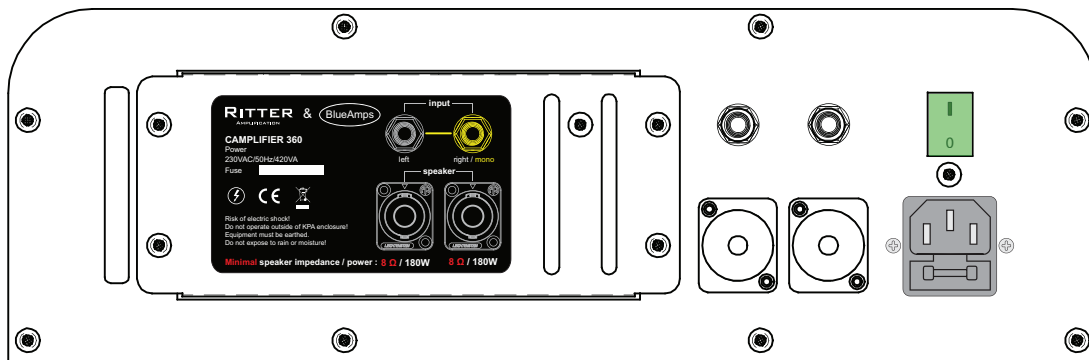

Keep this manual for future needs!



Table of Contents

Chapter	Page
1. Introduction	3
2. Safety Instructions	3 - 6
3. Legal Instructions	6
4. Operating Determinations	8
5. Description	9 - 10
6. Installation	11 - 13
7. Connections	14
8. Operation	19
9. Protective Circuits	20
10. Trouble Shooting	20
11. Cleaning and Maintenance	21
12. Technical Specifications	22

USER MANUAL



CAUTION!

Keep this device away from rain and moisture!
Unplug mains lead before opening the housing!

For your own safety, please read this user manual carefully before you initially start-up.

Every person involved with the installation, operation and maintenance of this device has to

- be qualified
- follow the instructions of this manual
- consider this manual to be part of the total product
- keep this manual for the entire service life of the product
- pass this manual on to every further owner or user of the product
- download the latest version of the user manual from the Internet

1 INTRODUCTION

Thank you for having chosen a CAMPLIFIER 360 add on amplifier module. If you follow the instructions given in this manual, we can assure you that you will enjoy this device for many years. Unpack your amplifier.

2 SAFETY INSTRUCTIONS



CAUTION!

Be careful with your operations. With a dangerous voltage you can suffer a dangerous electric shock when touching the wires!

This device has left our premises in absolutely perfect condition. In order to maintain this condition and to ensure a safe operation, it is absolutely necessary for the user to follow the safety instructions and warning notes written in this user manual.

Important:

Damages caused by the disregard of this user manual are not subject to warranty. The dealer will not accept liability for any resulting defects or problems.

If the device has been exposed to drastic temperature fluctuation (e.g. after transportation), do not switch it on immediately. The arising condensation water might damage your device. Leave the device switched off until it has reached room temperature.

English

Please make sure that there are no obvious transport damages. Should you notice any damages on the A/C connection cable or on the casing, do not take the device into operation and immediately consult your local dealer.

This device falls under protection-class I. The power plug must only be plugged into a protection class I outlet. The voltage and frequency must exactly be the same as stated on the device. Wrong voltages or power outlets can lead to the destruction of the device and to mortal electrical shock.

Always plug in the power plug least. The power plug must always be inserted without force. Make sure that the plug is tightly connected with the outlet.

Never let the power cord come into contact with other cables! Handle the power cord and all connections with the mains with particular caution! Never touch them with wet hands, as this could lead to mortal electrical shock.

Never modify, bend, strain mechanically, put pressure on, pull or heat up the power cord. Never operate next to sources of heat or cold. Disregard can lead to power cord damages, fire or mortal electrical shock.

The cable insert or the female part in the device must never be strained. There must always be sufficient cable to the device. Otherwise, the cable may be damaged which may lead to mortal damage.

Make sure that the power cord is never crimped or damaged by sharp edges. Check the device and the power cord from time to time.

If extension cords are used, make sure that the core diameter is sufficient for the required power consumption of the device. All warnings concerning the power cords are also valid for possible extension cords.

Always disconnect from the mains, when the device is not in use or before cleaning it. Only handle the power cord by the plug. Never pull out the plug by tugging the power-cord. Otherwise, the cable or plug can be damaged leading to mortal electrical shock. If the power plug or the power switch is not accessible, the device must be disconnected via the mains.

If the power plug or the device is dusty, the device must be taken out of operation, disconnected and then be cleaned with a dry cloth. Dust can reduce the insulation which may lead to mortal electrical shock. More severe dirt in and at the device should only be removed by a specialist.

There must never enter any liquid into power outlets, extension cords or any holes in the housing of the device. If you suppose that also a minimal amount of liquid may have entered the device, it must immediately be disconnected. This is also valid, if the device was exposed to high humidity. Also if the device is still running, the device must be checked by a specialist if the liquid has reduced any insulation. Reduced insulation can cause mortal electrical shock.

There must never be any objects entering into the device. This is especially valid for metal parts. If any metal parts like staples or coarse metal chips enter into the device, the device must be taken out of operation and disconnected immediately. Malfunction or short-circuits caused by metal parts may cause mortal injuries.

The device and all connections have to be lightning protected.

English

Only connect the device when the power switch is off.

Never connect the inputs or outputs to any power source (batteries, etc.)

Never connect output to output.

Before the device is switched on all faders and volume controls have to be set to "0" or "min" position.

Never connect the Speaker OUT of the CAMPLIFIER 360 to the signal OUT of the Kemper Profiling Amplifier!!

This would cause damage to the Kemper Profiling Amplifiers and the CAMPLIFIER 360!

English

CAUTION: Turn the amplifier on last and off first!

Please note that damages caused by manual modifications on the device or unauthorized operation by unqualified persons are not subject to warranty.

Keep away children and amateurs!



HEALTH HAZARD!

By operating an amplifying system, you can produce excessive sound pressure levels that may lead to permanent hearing loss.

There are no serviceable parts inside the device.

Maintenance and service operations are only to be carried out by authorized dealers.

3 LEGAL INSTRUCTIONS

Operating a guitar amplification system can produce extremely high noise levels that may cause a permanent hearing loss. The legal instructions for using an amplification system vary from country to country. The user must always inform himself on the legal instructions valid in his country and apply them to his situation.

Always monitor the sound pressure level when operating an amplification system in discotheques, concerts etc. Never exceed the permissible noise level exposures as specified by your authorities. The monitoring of the noise levels must be documented in an appropriate way.

In Germany, the following instructions are binding:

Strafgesetzbuch § 223 ff: bundesrecht.juris.de/bundesrecht/stgb

TA Lärm: www.umweltdaten.de

DIN 15905-5: www.din.de

Arbeitsstättenverordnung § 15: www.lgl.bayern.de/arbeitsschutz

Berufsgenossenschaftliche Vorschrift BGV B3: www.pr-o.info

VDI-Richtlinie: VDI 2058 Blatt 2: www.vdi.de

Hearing damage caused by high noise levels can be treated as physical injury and persecuted by law.

Please note that the organizer is responsible for keeping to a specified noise level. If this noise level will be exceeded, the event may be cancelled immediately.

If the organizer does not fulfil his safety duties, he is liable by civil law for any damages occurred, e.g.:

Pay the treatment costs of the damaged person.

Pay a smart money to the damaged person.

Economic damage caused can be demanded from the operator of the amplification system.

If hired persons work with amplification systems: the noise levels of music events are almost always too high. This is why the entrepreneur has to set up warning signs and provide hearing protectors. The staff has to use these.

Please note: Tilman Ritter / RITTER Amplification / Marco Wendel / BlueAmps and KPA-Solutions cannot be made liable for damages caused by incorrect installations and excessive noise levels!

3.1 Information on hearing loss

More and more young people suffer from hearing loss of 25 decibel or more, mainly caused by loud music from portable music players, discotheques, rock concerts or band rehearsals. Everybody operating amplification systems should know to what sound pressure levels he exposes his or the audience's hearing. As an average levels between 75 and 105 dB(A) in the discotheque or 95 and 115 dB(A) at a rock concert are reached. Individual peaks can exceed the pain level at 130 dB(A). Such levels are typical for motor chainsaws or jack hammers.

Overview on the different noise levels	
10 dB Heartbeat	80 dB Heavy traffic or telephone ringing
20 - 30 dB Whisper	90 dB Pneumatic drill
40 dB Average home	100 dB Power mower
50 dB Light traffic	120 dB Boom box in car
60 dB Normal conversation	130 dB Pain level
70 dB Vacuum cleaner	140 dB Jet plane 30 meters overhead

It is important to know that doubling the power increases the noise level by 3 dB. The human hearing does only recognize a doubling of the sound level when the noise level is increased by 10 dB. Damaging the hearing does not depend on the sound level but on the noise level and starts way before the pain level.

Many people deceive themselves by thinking that noise is something they can get accustomed to. It is possible that a positive opinion of a certain noise can reduce the physiological reaction, but the slow impacts on the inner hearing must not be neglected: over stimulation and continuous elimination of the Cortic organ's hair cells.

The reason why some people have got accustomed to a certain noise level and are no longer disturbed is that they have already suffered a hearing damage. This damage make the insensitive to those frequencies forming the loudest part of the noise. Getting accustomed to noise does not mean anything other than trying to get along with the hearing loss in everyday life. The hearing loss itself cannot be healed, it can only be compensated by hearing aids.

Subjectively, the hearing loss feels like dampened ears. This effect weakens with the time, but a loss in hearing sensitivity often remains.

In order to relax the hearing sufficiently, the noise level should not exceed 70 dB(A) for 10 hours. Higher noise levels during this relaxing period can prevent the relaxation and promote a permanent hearing damage (Tinnitus) or hearing loss.

Therefore: Whoever wants to maintain his hearing should use hearing protectors!

4 OPERATING DETERMINATIONS

The CAMPLIFIER 360 add on amplifier module has been specially designed for the operation mounted INSIDE of the Kemper Profiling Amplifier (KPA).

Any operation of the CAMPLIFIER 360 outside of the KPA is forbidden!

The CAMPLIFIER 360 may be used to provide power amplification to speaker cabinets. The signal source must be the Kemper Profiling Amplifier (KPA).

Please note that the speaker systems connected to the Camplifier must provide a **minimal** impedance of **8 ohms** and must be capable of handling at least **180W**rms.

Speaker system impedances bellow 8 ohms might damage the CAMPLIFIER 360!

Speaker systems with a specified max. power handling capacity of less than 180W might be damaged by the CAMPLIFIERS high power output!

This product is allowed to be operated with an alternating current of 230 V, 50 Hz and was designed for indoor use only.

This device is designed for mobile use and for permanent installations.

By operating amplifying systems, you can produce excessive sound pressure levels that may lead to permanent hearing loss. Please refer to the explanations under “Legal instructions”.

Please note: operating an amplification system in public or industrial areas, a series of safety instructions have to be followed that this manual can only give in part. The operator must therefore inform himself on the current safety instructions and consider them.

Do not shake the device. Avoid brute force when installing or operating the device.

When choosing the installation-spot, please make sure that the device is not exposed to extreme heat, moisture or dust. There should not be any cables lying around. You endanger your own and the safety of others!

This device must never be operated or stockpiled in surroundings where splash water, rain, moisture or fog may harm the device. Moisture or very high humidity can reduce the insulation and lead to mortal electrical shocks. When using smoke machines, make sure that the device is never exposed to the direct smoke jet and is installed in a distance of 0.5 meters between smoke machine and device.

The ambient temperature must always be between -5° C and +45° C. Keep away from direct insulation (particularly in cars) and heaters.

The relative humidity must not exceed 50 % with an ambient temperature of 45° C.

This device must only be operated in an altitude between -20 and 2000 m over NN.

The ambient contamination must never exceed level 1 and must not be conducting, only dry.

Never use the device during thunderstorms. Over voltage could destroy the device. Always disconnect the device during thunderstorms.

Operate the device only after having familiarized with its functions. Do not permit operation by persons not qualified for operating the device. Most damages are the result of unprofessional operation!

Never use solvents or aggressive detergents in order to clean the device! Rather use a soft and damp cloth.

Please use the original packaging if the device is to be transported.

Never remove the serial barcode from the device as this would make the guarantee void. Please consider that unauthorized modifications on the speaker system are forbidden due to safety reasons!

If this device will be operated in any way different to the one described in this manual, the product may suffer damages and the guarantee becomes void. Furthermore, any other operation may lead to dangers like short-circuit, burns, electric shock, hearing loss etc.

5 DESCRIPTION

5.1 Features

Stereo add on amplifier module for the Kemper Profiling Amplifier

- Complete protection set against short-circuit, overheat, over voltage, overload
- Fan cooling
- Signal inputs via 6.3 mm mounting jacks
- Speaker outputs via lockable Speakon sockets
- Designed to fit into the open space at the KPAs back side

5.2 Operating elements and connections

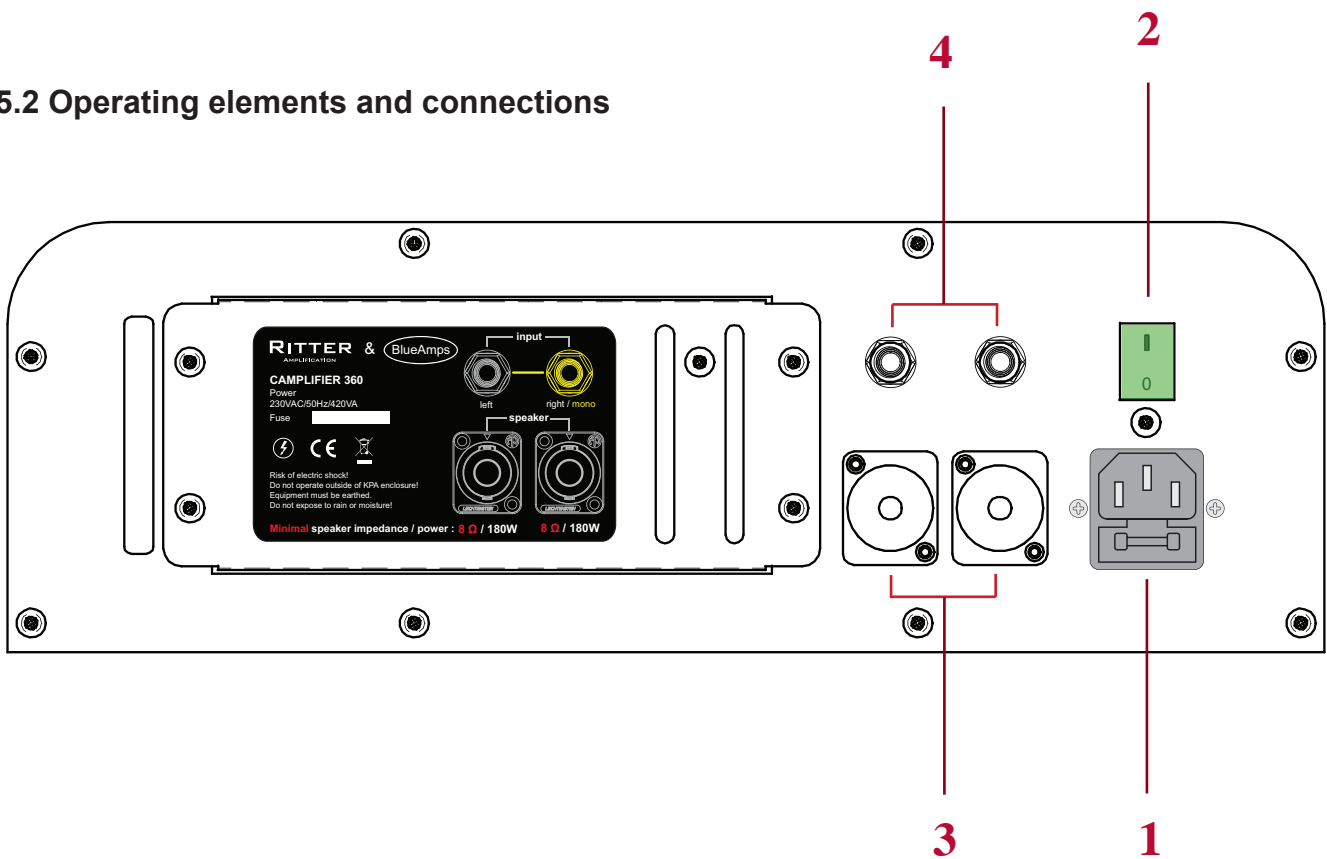

1 AC input with fuse holder Used to plug the supplied power cord in. Only replace the fuse when the device is disconnected from mains. Only use fuses of the same rating and power (2AT). The correct fuse value is specified on the rear panel.

2 Power on/off switch

3 Speaker connectors Speaker jacks for stereo operation and mono operation using the signal supplied to the right signal 6,3mm jack input only.

4 Input jacks for the right and left channel for stereo operation. The right input jack provides signal to both speaker outputs if the left input jack is not used.

6. Installation / Assembly

Preface :

The CAMPLIFIER 360 is designed to operate as an add on module inside the Kemper Profiling Amplifier.

Any operation outside of the Kemper Profiling Amplifier can cause damage to equipment and cause mortal electrical shock.

Should you experience any difficulties when installing the CAMPLIFIER 360 into the Kemper Profiling Amplifier , please contact our technical support at :

Tilman Ritter
RITTER Amplification
Veteranenstrasse 3
01139 Dresden
Tel. : 0351 160 51 982
info@kpa-solutions.com

Please do **NEVER** connect the power cord to the CAMPLIFIER 360 when the unit has not been assembled into the Kemper Profiling Amplifier correctly!

6.1 Preparation prior Installation

Check the upper chamber at the back side of the Kemper Profiling Amplifier (KPA) for objects such as cables, paper, guitar picks, guitar strings etcetera. Remove all objects from this chamber!

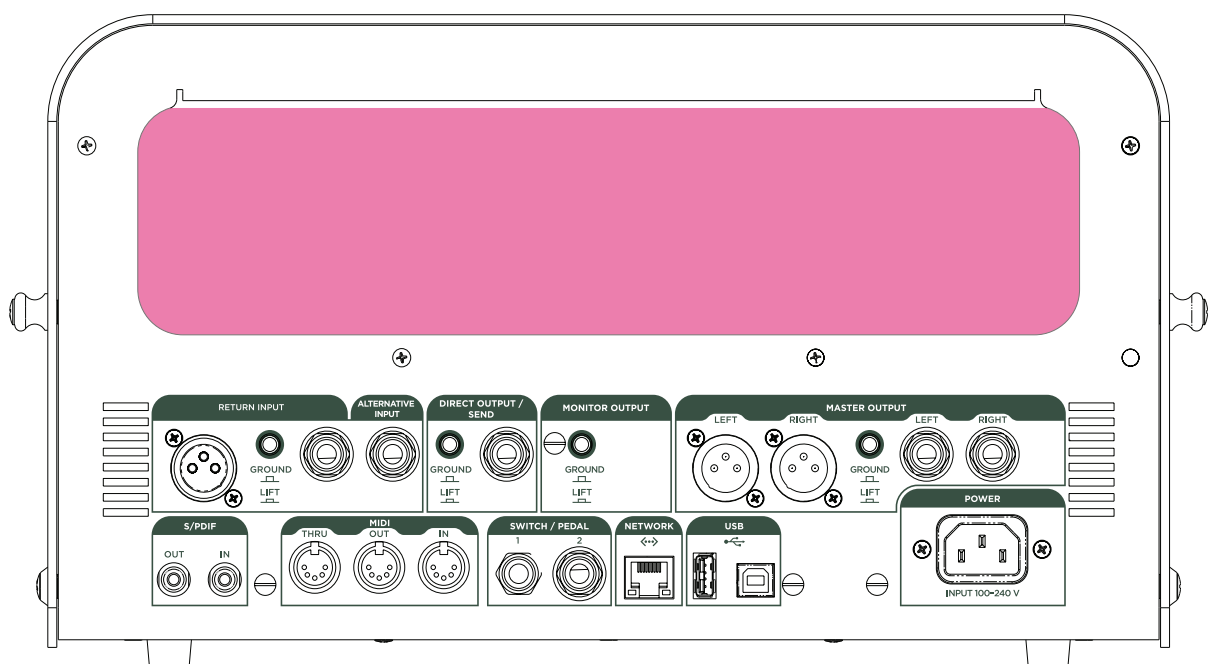

English

Remove all 8 screws that surround the KPAs back chamber. You will need a TORX 10 screwdriver to do that.

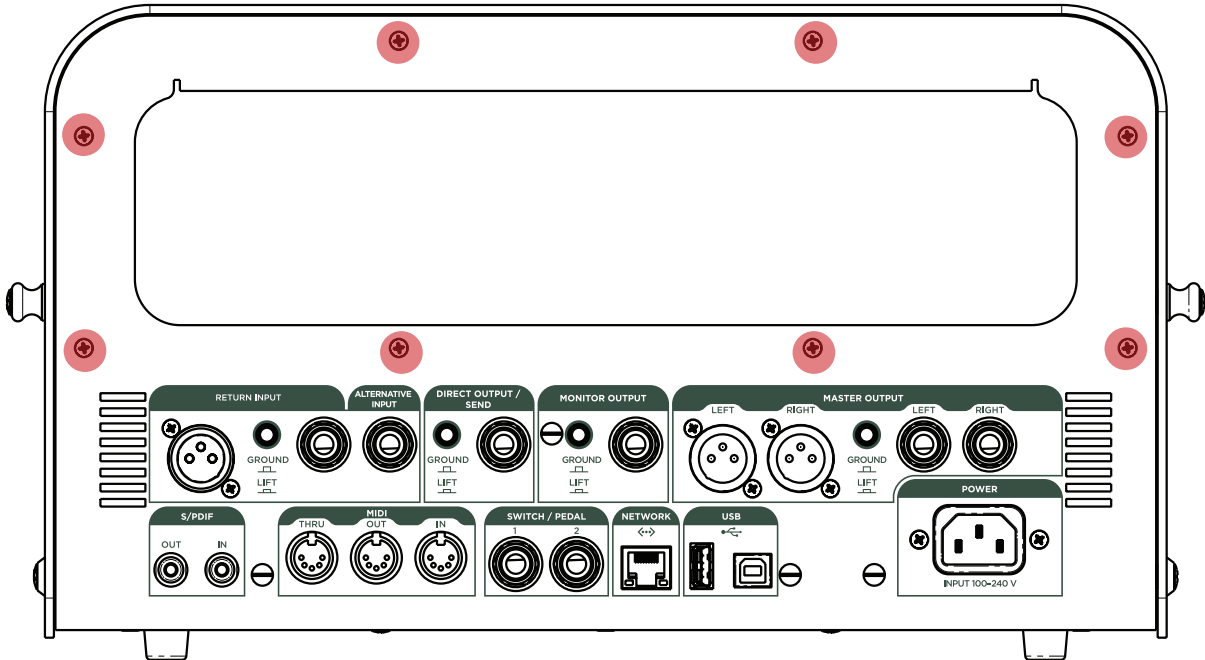

Additionally to the power cord that has been delivered with your CAMPLIFIER 360, 8 small screws have been delivered with it too. Please find them and consign them close to your KPA together with a Phillips screwdriver apposite to those 8 screws.

Consign the CAMPLIFIER 360 handy. Make sure no objects such as packing material, tape, paper etcetera are attached to the CAMPLIFIER 360 any more. The CAMPLIFIERS fan wheel should turn freely and must not be blocked by any objects.

6.2 Installation

Insert the CAMPLIFIER 360 slowly and carefully into the back chamber of the KPA.
It might be helpful to put the KPA carefully on its operation side for this.

Please make sure the CAMPLIFIER can be inserted smoothly and without any tension.

Align the 8 mounting holes of the CAMPLIFIER 360 as good as possible to the threaded holes at the back sheet metal of the KPA.

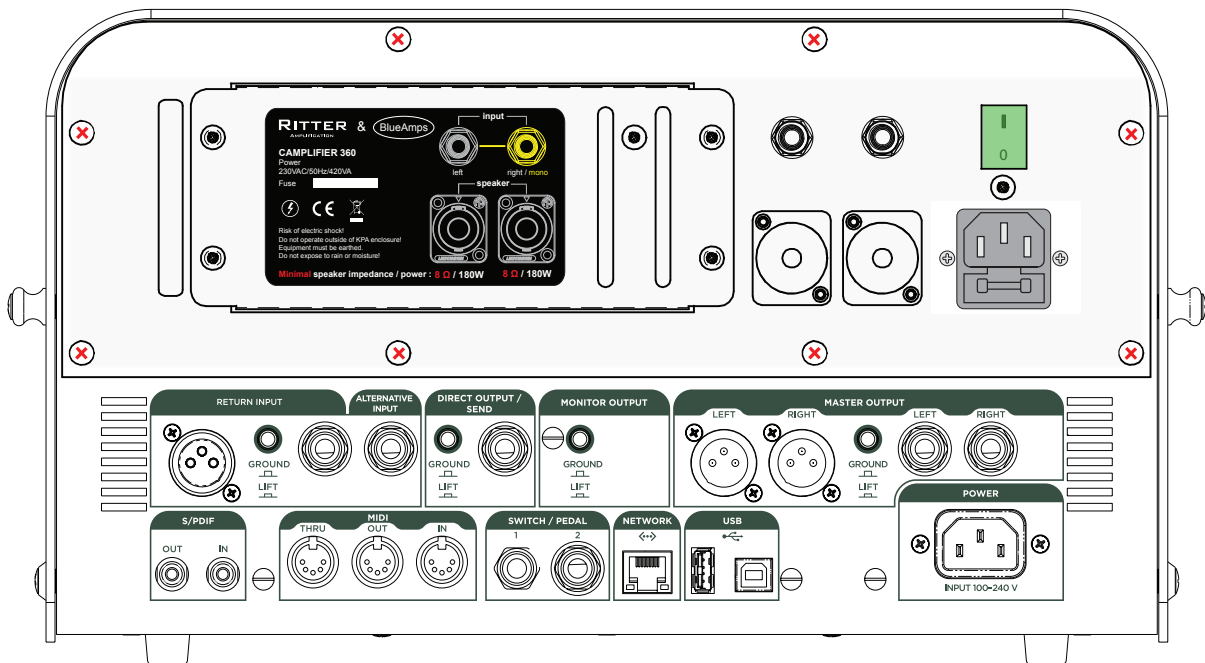

Screw the Camplifier onto the KPA with the 8 screws that have been delivered with the Camplifier.

Congratulations! You have successfully installed the CAMPLIFIER 360!

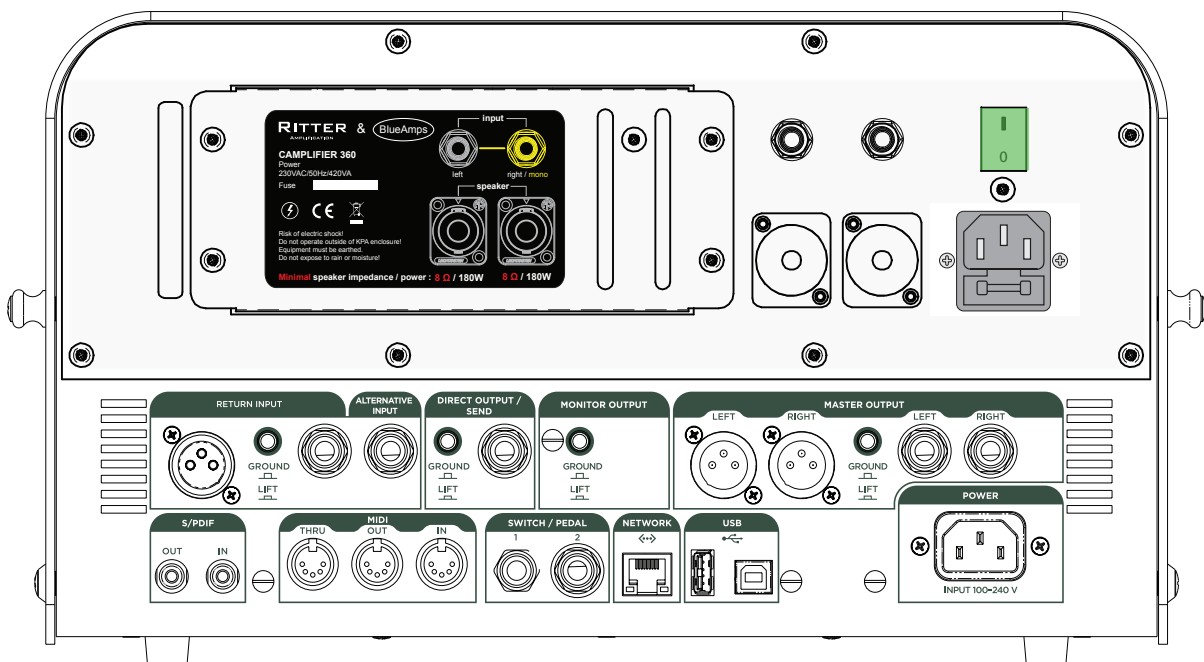

7 CONNECTIONS

All connections have to be made or changed only if the amplifier is switched off!

7.1 Inputs

Connect the output of the KPA to one of the jacks to the Amplifiers INPUT sockets.
The input signal should have line level.

Information on installing speaker cables

Input cables should be short and direct, since high frequencies will mostly be absorbed if the cables are unnecessarily long. Besides that a longer cable may lead to humming and noise trouble. If long cable runs are unavoidable, you should use balanced cables.

Occupation jack plug:

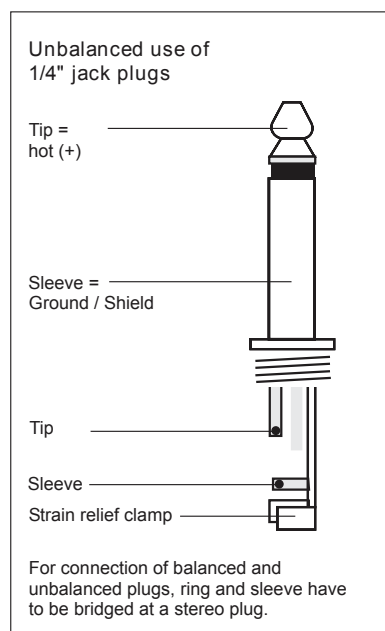

7.2 Speaker outputs

In stereo mode, the amplifier can operate two speakers or two speaker groups.

For connecting speakers, Speaker jacks are provided. When using the Speaker jacks, turn each plug to the right until it locks into place. For unlocking, pull the unlock button and turn the plug to the left.

- **Occupation Speaker socket:**

PIN		
1 +	2 +	+
1 -	2 -	-

Example for the calculation number of speakers/impedance

Number of Speakers	Impedance
1 Speaker at 8 ohms	8 ohms
2 Speakers at 8 ohms	4 ohms parallel wired
2 Speakers at 8 ohms	16 ohms connected in series
1 Speaker at 16 ohms	16 ohms
2 Speakers at 16 ohms	8 ohms parallel wired
2 Speakers at 16 ohms	32 ohms connected in series

The Speakers Impedance must be greater than 8 ohms / channel at all times !

Information on choosing appropriate connection cables

- Speaker systems must only be connected via sufficiently dimensioned cables. Too thin cables lead to cable heat up or enormous power loss and loss in sound quality.
- For all speaker systems up to 400 Watts, we recommend a cable diameter of 2.5 mm², for all other speaker cables 4 mm².
- A high damping factor of your amplifier supplies a clear sound reproduction. Unnecessarily long and thin cables will influence the damping factor and thus the low frequencies in a negative way. In order to safeguard good sound quality, the damping factor should lie around 50. The longer a cable has to be, the thicker it should be. In this respect, a damping factor of 200 will be reduced to 47 (8 ohms) when using a 10 m long, 2.5 mm² speaker cable. The power loss at 8 ohms is 1.63 %, at 4 ohms 3.25 % and at 2 ohms even 6.5 %.
- The maximum cable length is 30 meters!

Information on installing speaker cables

- Always treat cables carefully and protect them from damages during transportation.
- Install cables always in a structured way and protect them from damage.
- Cables must be installed in a way that no person can stumble over them. Always fix cables with an appropriate tape.
- Both cables should be of the same kind.
- Both cables should have the same length.
- Both cables should be installed directly (no loops, S-shaped over lengths)
- Always install the cables far away from power cables (never closely parallel)
- Never put heavy objects like speaker systems, flight cases etc. on cables.
- Never wind up cables tightly around the elbow, but rather sleek with an interior diameter of 20 to 30 cm.

7.2.1 Stereo Operation

The most frequently used operating mode of the Camplifier 360 might be stereo operation, where both channels are operated independent of each other. The highest output power during stereo operation is achieved by connecting 8 ohms speakers. With 16 ohms speakers the output power will be slightly reduced. For stereo operation, use both speaker pairs at the speaker output sockets and insert signal jacks into both input sockets at the Camplifier 360.

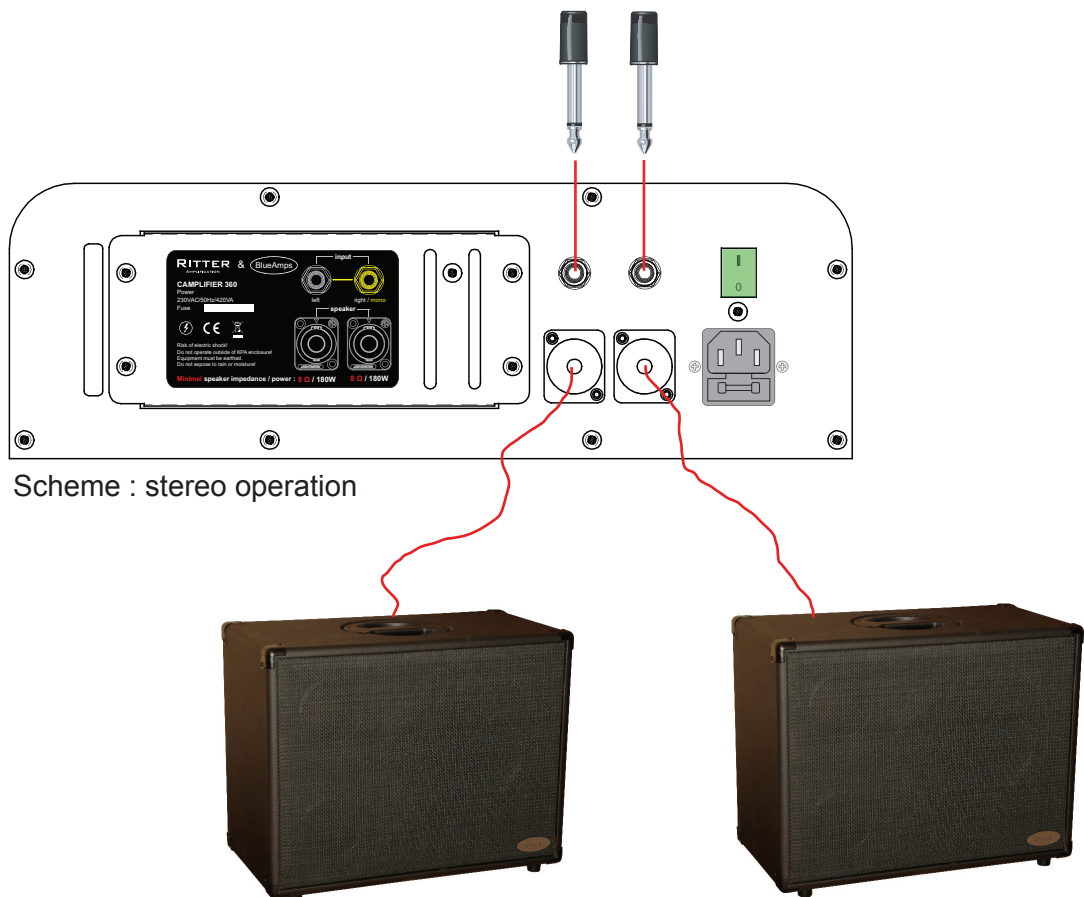

7.2.2 Mono Operation (both speakers operate)

Both speaker outputs will be driven by the same input signal. This input signal is fed to the RIGHT signal input socket (marked yellow at the connection scheme at the Camplifier).

The highest output power during stereo operation is achieved by connecting 8 ohms speakers. With 16 ohms speakers the output power will be slightly reduced.

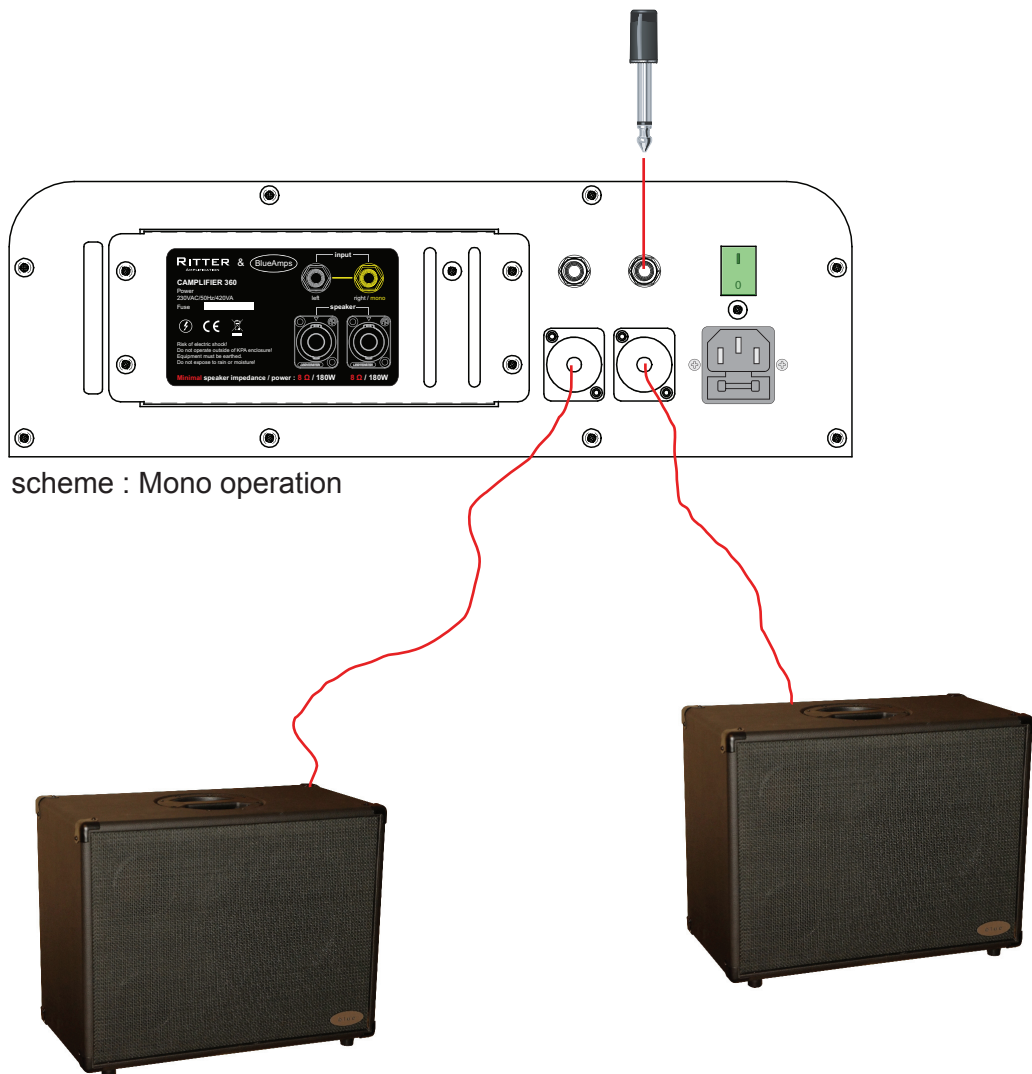

7.2.3 Single channel operation

Only a single speaker is connected to one of the speaker output sockets.

Only one channel is operating, the other one is on idle mode.

For this operation mode, please use the LEFT channel.

Hence connect the signal input to the LEFT channels input socket and the speaker cabinet to the LEFT speaker output socket of the Amplifier.

Doing so will ensure the idle mode of the right channel.

The highest output power during stereo operation is achieved by connecting 8 ohms speakers. With 16 ohms speakers the output power will be slightly reduced.

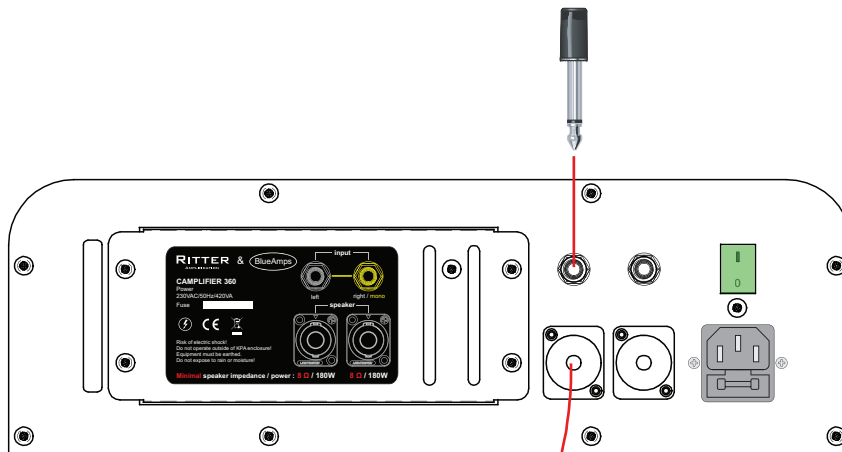

scheme : single channel mode



7.3 Connection with the mains

Finally connect the device to the mains with the supplied mains cable. The occupation of the connection cables is as follows:

brown wire - live wire - L
blue wire - neutral - N
yellow/green wire - protective earth

The earth has to be connected! If the device will be directly connected with the local power supply network, a disconnection switch with a minimum opening of 3 mm at every pole has to be included in the permanent electrical installation. The device must only be connected with an electric installation carried out in compliance with the IEC standards. The electric installation must be equipped with a Residual Current Device (RCD) with a maximum fault current of 30 mA.

8. OPERATION

8.1 Selecting the operating mode

Connect the signal inputs and the speaker connections apposite to the operation mode you want to choose.

- Stereo (refer to 7.2.1)
- Mono (refer 7.2.1)
- Single (refer to 7.2.3)

8.2 Switching on/off

To prevent loud switching noise, always switch on all other units of the amplifier system before switching on the power amplifier. After operation, switch off the power amplifier first. Prior to switching on set the level controls at the KPA to minimum. Then switch on the Camplifier with the power switch. The power switch will be light green. If it does not, check if the amplifier is connected to the mains correctly.

8.3 Adjusting the level

Carefully increase the volume by turning the volume control at the KPA higher slowly until you reach your desired volume level. There should be no loud humming. Should humming persist, check the connection cables between the Camplifier and the KPA (switch off components before).

Additional information on the operation

When operating the amplifying system, please make sure that the loudspeakers always sound well. When distortions can be heard, either the amplifier or the loudspeaker is overloaded. Overloads can quickly lead to amplifier or speaker damage. In order to avoid damage, please reduce the volume immediately when distortions can be heard. When speaker systems are destroyed by overload, the guarantee becomes void. Always check the sound pressure level with a meter in order to keep to the threshold.

9. PROTECTIVE CIRCUITS

The integrated protective circuits prevent damage to the speakers and the amplifier. If activated, the Camplifier will shut down its power amplifier section.

The protection will be activated if:

- the amplifiers temperature is too high
- a short circuit and therefore a too high current in the speakers output occurs

If the Camplifier shuts down during operation, the amplifier has to be switched off and the cause of the fault has to be removed.

The cause could be a damaged speaker cable, speaker plug, broken speaker chassis, a too low speaker impedance or an insufficient ventilation at the back of the Camplifier.

10. Trouble Shooting

Problem	Cause	Remedy
No Power.	The power cord is not connected.	Check the power cord and any extension cables.
No Sound.	The power cord of the respective device is not connected properly or not connected at all. The connection socket or the plug is dirty.	Check the power cord and if the plugs are tightly connected with the sockets. Clean the socket and/or the plug.
Fan does not work, Power switch does not light up.	The power cord is not connected. Fuse is broken.	Please check if the power is available. Check the fuse
Camplifier shuts down during operation	Speaker impedance is < 8 ohms. The ventilation openings at the Camplifiers back plate are blocked - no ventilation.	Check the speakers impedance. Remove all objects from the KPAs back and move the KPA at least 20cm away from walls and curtains.

11. CLEANING AND MAINTENANCE



DANGER TO LIFE!

Disconnect from mains before starting maintenance operation!

We recommend a frequent cleaning of the device. Please use a soft lint-free and moistened cloth. Never use alcohol or solvents!

There are no serviceable parts inside the device except for the fuse. Maintenance and service operations are only to be carried out by authorized dealers.

11.1 Replacing the fuse

If the fine-wire fuse of the device fuses, only replace the fuse by a fuse of same type and rating.

Before replacing the fuse, unplug mains lead.

Procedure:

Step 1: Open the fuse holder on the rear panel with a fitting screwdriver.

Step 2: Remove the old fuse from the fuse holder.

Step 3: Install the new fuse in the fuse holder.

Step 4: Replace the fuse holder in the housing.

Should you need any spare parts, please use genuine parts.

If the power supply cable of this device becomes damaged, it has to be replaced by a special power supply cable available at your dealer.

Should you have further questions, please contact us or your dealer.

Contact information:

Tilman Ritter
RITTER Amplification
Veteranenstrasse 3
01139 Dresden
Tel. : 0351 160 51 982
Info@kpa-solutions.com

English

Power supply	230 V AC, 50 Hz ~
Power consumption	420W max.
Audio power output RMS at 2 x 8 ohms	2 x 178W
Frequency range	25Hz – 25kHz +/- 0.5dB
Damping factor	>350
Distortion factor	THD 1% bei max. RMS Leistung
Noise voltage	<40uVrms unweighted
Channel separation	79dB @ 1kHz and 1W
Input sensitivity	0,77V
Input voltage	max. 21 dBV/9V
Input impedance	20 kohms
Input sockets	2 x 1/4" unbalanced
Speaker output connection	2 x Speakon socket
Minimum speaker impedance	8 ohms
Control elements	Power switch
Protection circuits	Over current, Over voltage, Over temperature
Dimensions	350x85x77mm (13,8"x3,4"x3")
Weight	1kg (2,2 lbs)

Please note: Every information is subject to change without prior notice.