

molift[®]

PARTNER230E



CE

- a patient lifter from

molift[®]
designed for life

OPERATOR MANUAL

Table of Contents

General advice	3
<i>Explanation of symbols</i>	3
<i>Before using the patient lifter</i>	3
<i>Responsibility</i>	3
Safety precautions	4
<i>General</i>	4
<i>If defects or faults occur</i>	4
<i>Lift and transfer</i>	4
About the product	5
<i>Main parts</i>	5
<i>Safety devices</i>	5
Technical data	6
Assembly / disassembly	7
<i>Assembly and use of charger</i>	7
<i>Unpacking</i>	7
<i>Assembly</i>	7
<i>Checklist before use</i>	8
<i>Disassembly</i>	8
Operation	9
<i>Battery care and charging</i>	9
<i>Battery capacity</i>	9
<i>Operating the hand control</i>	9
<i>Emergency stop and lowering</i>	9
<i>Lift and transfer</i>	10
<i>Use of spread legs</i>	11
<i>Using lifting slings</i>	11
<i>Lift and movement to and from bed</i>	12
<i>Lift and transfer to and from floor</i>	13
<i>Lift and transfer to and from (wheel) chair</i>	14
<i>Bathing</i>	15
<i>Toileting</i>	16
Accessories	17
<i>Lifting sling</i>	17
Maintenance	19
<i>Daily maintenance</i>	19
<i>Monthly maintenance</i>	19
<i>Service / yearly maintenance</i>	19
<i>Troubleshooting</i>	20

IMPORTANT!

The patient lifter is only meant to be used by qualified personnel.

The manual shall not be handed over, or made available to, any unauthorised third party, without a prior written consent from Molift AS. Existing laws, conventions and agreements protects all documents. No extract of this documentation can be reproduced, used or transferred without prior written consent from Molift AS. Violation of these regulations may lead to judicial repercussions and economic responsibility. Industrial rights are reserved.

molift[®]
designed for life

Molift AS

Ole Deviksvei 44

0668 OSLO, Norway

Teleph:(+47) 40001004

Fax: (+47) 40001008

www.molift.com

info@molift.com

General advice

This user manual contains important safety instructions and information regarding the use of the lifter. Carefully read the manual before using the lifter in order to be familiar in the function and use of the lifter.

Explanation of symbols



This symbol is used to point out instructions and information related to work place safety where injury may occur if the information is disregarded or ignored. Follow these instructions, be careful and attentive at all times.



This symbol indicates important information regarding the use of the equipment. If not taken into consideration, it may lead to damage or functional defects to the lifter or other equipment.



This symbol indicates important and useful information. If taken into consideration, it will help the operator of the lifter to work efficiently. It may help simplify routines and to explain complicated facts.

Before using the patient lifter

Before using a patient lifter, the operator must be trained accordingly. Practice lifting a colleague, and be lifted by others. It is important not only to know how to move another person using the lifter, but also how it is to be lifted. Try out and practice using all the relevant slings for the different types of lifter and movement you may encounter. Before lifting a person, you should explain the procedure.

When using the lifter, it's also important to use the correct sling and accessories according to:

- type of disability
- size
- weight
- type of movement

Responsibility

Please read these operating instructions carefully before putting the product into operation. We assume no liability for damage or malfunctions resulting from failure to comply with the instructions. Warranty claims must be made immediately on detecting the defect. Remember to quote the serial number. Consumable parts are not subject to the warranty.

All technical information, data and instructions for operation contained in these operating instructions were up-to-date at time of print and are compiled on the basis of our experience and to the best of our knowledge. We reserve the right to incorporate technical modifications within the scope of further development of the product described in this manual. No claims can be derived from the information, illustrations or descriptions contained in these instructions. We assume no liability for any damage or malfunction caused by operating errors, non-compliance with these operating instructions or inappropriate maintenance. We expressly point out that only genuine Molift AS spare parts and accessories approved by us may be used. For safety reasons, the fitting and use of spare parts or accessories, which have not been approved, and unauthorised modification or conversion of the product, are not permitted. Molift AS will accept no liability for damages resulting from such acts.

With the exclusion of product liability, Molift AS is liable for faults or omissions on its part within the scope of the warranty obligations stated in the purchase contract. Claims for damages are excluded, irrespective of the legal reason from which such claims are derived. Only documentation belonging to the actual equipment is valid.

Any failure to comply with the safety regulations and precautionary measures stated in these operating instructions renders the declaration of conformity supplied with the system in accordance with Council Directive (93/42/EEC) concerning medical devices invalid.

Safety precautions

General

Before putting a Molift PARTNER 230E into operation, the operator must ensure that the lifter and accessories are in good working order, especially with regards to safety. All instruction and information in this manual regarding safety and general precautions must be read, understood and followed carefully. Any disregard to these precautions may result in personnel injury or damage to the equipment. The lifter must be taken out of service immediately, or not returned to use, if faults and/or irregularities that may have influence on the safety are discovered.

Safety devices and -equipment must not be removed, disabled or in any other way altered. A Molift PARTNER 230E shall only be used when all safety devices and equipment is in place and fully operational.

 *The lifter is designed for use in room temperature, +10 to +40 °C. This should be taken into consideration when transporting the lifter, and therefore keeping it in a temperate part of the vehicle. Alternatively, the lifter must rest in a temperate room until the equipment has achieved proper working temperature.*

If defects or faults occur

The lifter must be switched off immediately if one of the following conditions occur;

- damage to electrical devices or cables, or damage to parts of electrical insulation
- damage or failure on safety devices

 *If the lifting movement does not start when the corresponding button is pressed, please consult the fault finding table in the maintenance chapter to locate the fault.*

Injury to personnel or equipment may occur if Molift PARTNER 230E is used in an incorrect manner and if:

- covers are removed by unauthorised personnel
- used incorrectly
- insufficient maintenance

- load exceeds maximum limit. The maximum load stated in this manual and on the lifter is the maximum load
- unauthorised repair of electrical devices or cables

Lift and transfer



The patient lifter may tip over if used incorrectly! Ignorance of warnings and instructions may lead to personnel injury. Read instructions carefully before attempting to lift anyone.



The Molift PARTNER 230E has a Safe Working Load on 230 kg, meaning that it is tested and approved for lifting of patients up to 230 kg.

Several factors have to be considered during movement of the lifter:

- the user shall sit as low as possible facing the lifting column
- the user should rest their feet on the chassis

Stand to the side of the user when lifting. Ensure that arms and legs are clear of the lift, chair, bed etc. Try to maintain eye contact with the user - this will help the user feel safe and comfortable.



Pay close attention to your actions. Ensure that all four loops of the sling are securely fastened to avoid the user slipping or falling



Use the drive handles when manouvring the lifter, do not push or pull the patient, suspension or lifting arm.



Do not touch the underside of chassis or between chassis and legs when monouvring the legs.



Molift slings shall ONLY be used to lift persons. NEVER use the sling to lift and/or move objects of any kind.

About the product

Molift Partner 230E is a mobile lifter intended for lifting and transferring persons. The lifter is made out of light materials, it has castors, electrical adjustable legs and a battery. It is therefore ideal for use in institutional care.

Main parts

The lifter is built around a chassis unit comprising a lifting column fixing unit, rear castors and spreading mechanism for legs. The adjustable legs are operated by an electrical motor and gives the operator a possibility to adjust the width of the lifter to different needs and situations. On the lifting column there is a drive handle and a battery holder. On the battery holder there is a connection for the hand control and an emergency stop button.

On the lifting column there is a trolley on which the lifting arm is attached. The suspension is attached to the lifting arm, and the suspension rotates freely, allowing the Molift PARTNER 230E to be used at any angle.

Safety devices

Molift PARTNER 230E is equipped with several safety devices, which are intended to prevent damage to personnel and equipment in the case of incorrect use.

- The lifter has an overload sensor preventing the lifter to be operated with more than 230 kg.
- The lifting arm is hinged to prevent the arm and suspension from squeezing the patient if it is lowered too much. The lifting arm will not produce any force when moving downwards.
- The suspension has safety hooks to prevent the sling loops to fall off.
- When activating the emergency stop button, the power supply will be disconnected, and the lifter will stop.
- If an error occurs on the lifter, it is possible to lower the lifting arm electrically on the battery holder or manually by operating the emergency lowering switch on top of the column.
- The lifter has a service lamp which gives a signal when the lifter needs service.

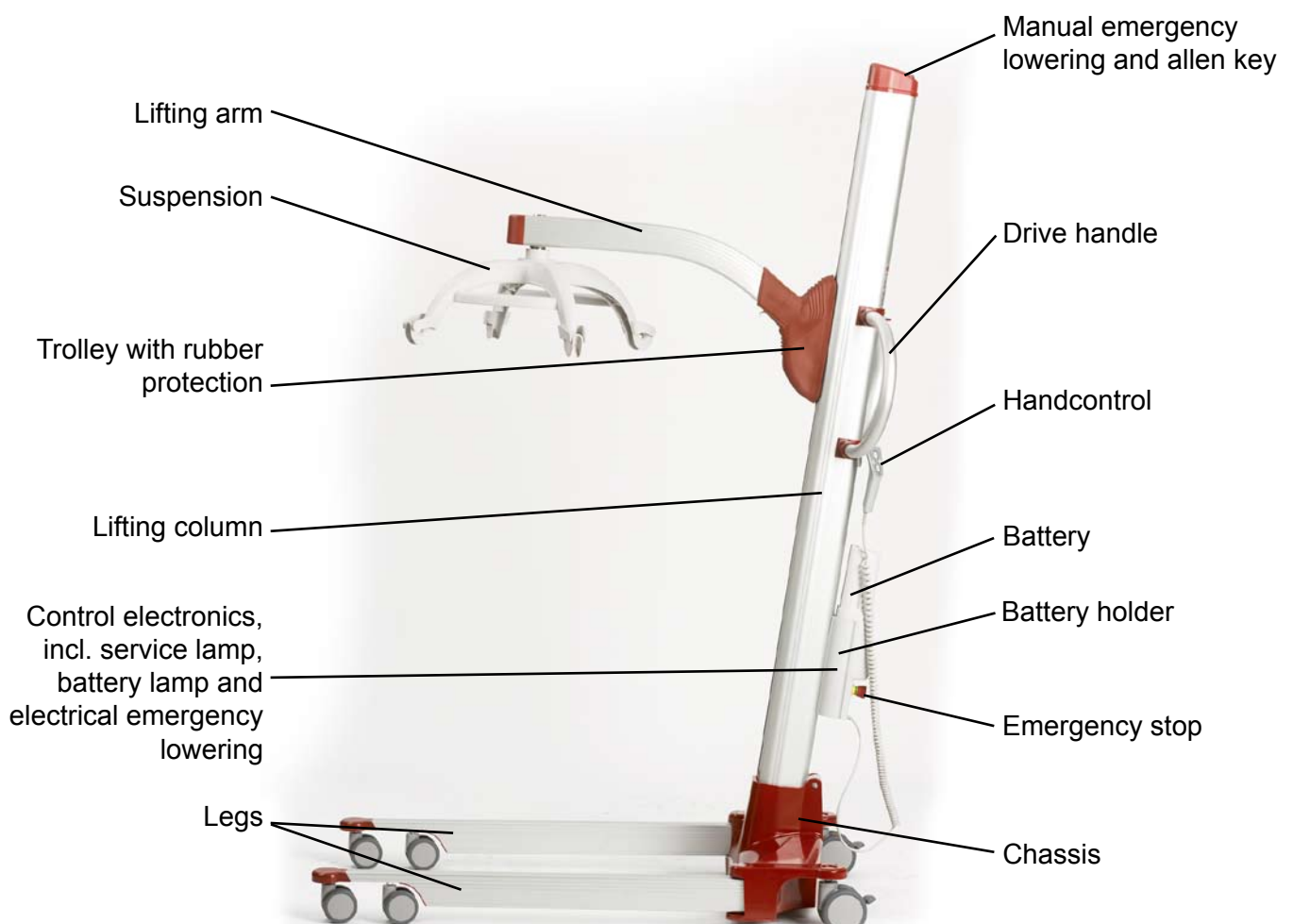

Technical data

Weight, totally:

excl. battery; 40 kg / incl. battery: 41,5 kg

Material:

Steel, aluminium and composite plastic

Motor:

24 V DC

Battery:

26,4 V NiCd 1,9 Ah
Molift PowerPac

Number of lift with fully charged battery:

75 lifts (75 kg, 50 cm)

Safe Working Load (SWL):

230 kg

Lifting height:

1275 mm

Lifting speed:

30 mm/sec (75 kg)

Height of legs:

110 mm

Measurements:

1175 x 700 x 1902 mm (LxBxH)

Measurements in illustrations below are in millimetres.

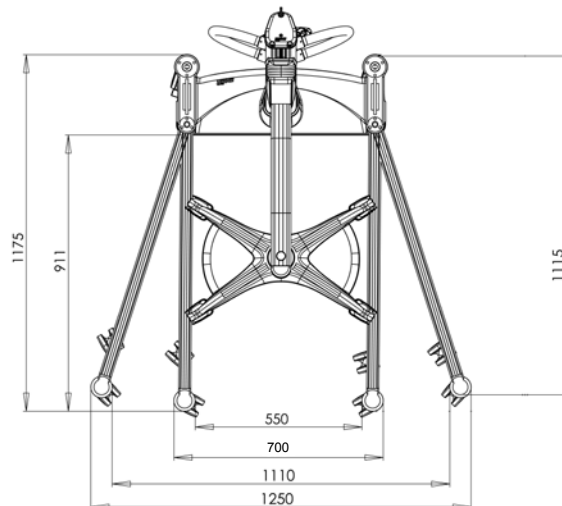
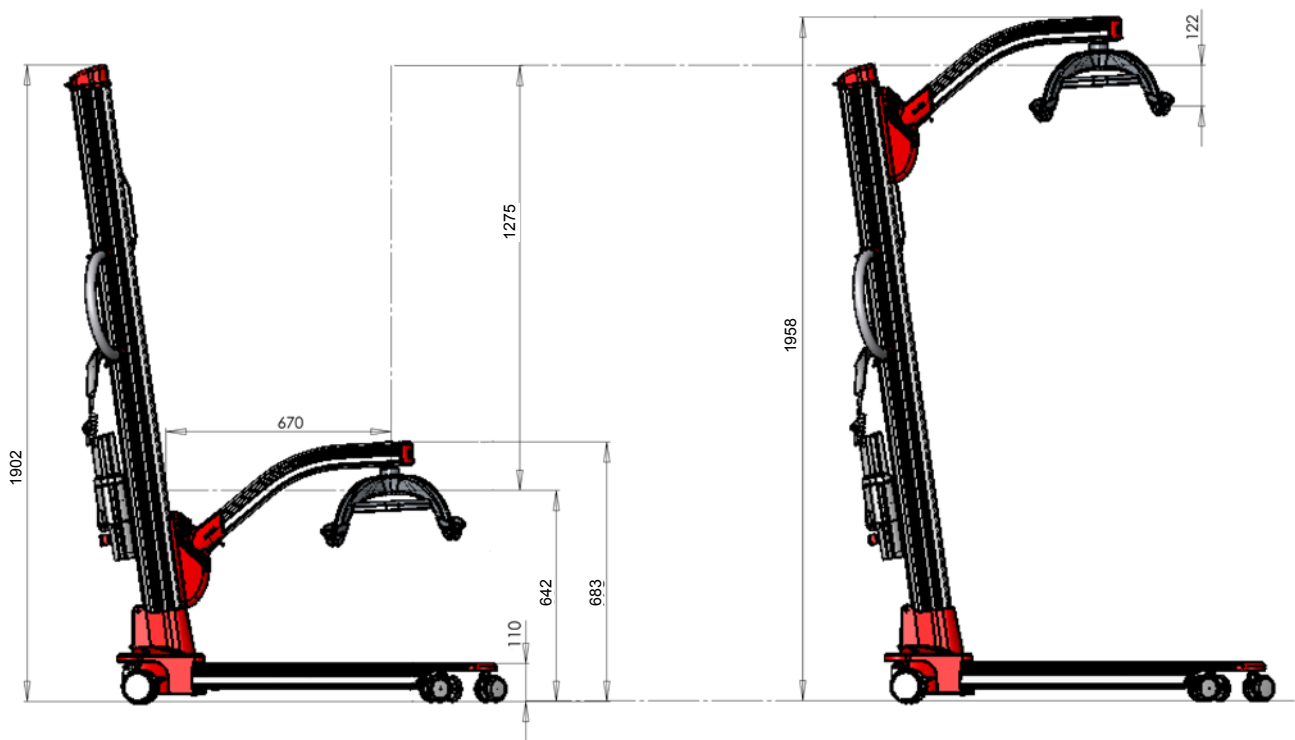

Assembly / disassembly

To be able to operate the Molift Partner 230E, the operator must have good knowledge of the lift, including assembly, disassembly and preparation before use.

Assembly and use of charger

The charger shall be connected to the power outlet at all times. It is possible to mount the charger on a wall surface or place it on a table.

 *Molift AS tests and charges all batteries before packing and shipment. However, all batteries must be charged before use.*

Unpacking

- The lifter comes in one cardboard box. Verify that the box has no apparent damage. If damaged, - check the content and contact your dealer for assistance if components are damaged.
- The box contains chassis, lifting column, lifting arm with suspension, drive handle, hand control, battery and battery charger.

Assembly

- The chassis should be rolled out of the box.

 *The battery must not be in the battery holder during assembly!*

- Place the column in the attachment on the chassis, and the column will find the correct position. If the column does not place itself correctly, rotate the drive with the unbraco key on the top and try again until the column has found the correct position.
- Make sure that the red arrow on the lower part of the column corresponds with the edge on the chassis. Fix the column with the lock handle.

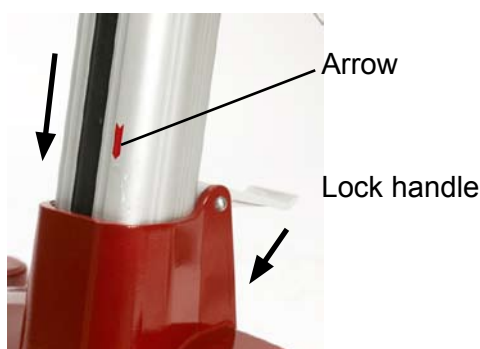

- Mount the lifting arm with suspension and rubber protection on the trolley on the lifting column.



- Slide the rubber protection up on the arm and guide the lifting arm on the trolley. Push the arm down until the locking handle makes a clear click when the lifting arm is fixed correctly.

 *Be careful not to put fingers or similar under the lifting arm between arm and trolley. Danger of personal injury.*

- Slide the rubber protection back to cover the trolley, and pull it over the top and bottom edge.
- Connect the hand control cable to the contact on the battery holder. The hand control has a hook that makes it possible to hang it on the drive handle or the plastic hooks on the column.
- Place the battery in the holder with the connectors facing down. Release the emergency stop and run each function of the lifter a couple of times without load to verify proper function.

 *Molift AS tests all lifters with and without load before shipment. The control is an extra precaution to uncover any shipment damage and/or incorrect assembly.*

Checklist before use

- Check that the lifter has no apparent damage or other faults, especially that the suspension has no damage or cracks.
- Ensure that the lifting arm and lifting column are properly fixed and that there is no loose parts on the lifter.
- Check that the emergency button is deactivated and that the lifter works.
- Check that you have sufficiently charged batteries to complete the task you have planned.
- Check that the servicelamp gives a green light indicating it is ready for use. If the servicelamp gives a yellow or red light, the lifter needs service.



Make sure that the suspension has no damage or cracks, and that the lifting arm and column is properly fixed before use!

Disassembly

- Remove the battery.
- Remove the lifting arm with rubber protection by pulling the locking handle up and forwards while lifting the lifting arm.
- Release the lock handle on the chassis, and then lift off the lifting column.



It is recommended that the emergency stop is activated during storage for safety reasons.

Operation

Battery care and charging

Molift Partner 230E is supplied with a battery with a 26,4 V cell unit that is placed in the battery holder on the lift. A charger is also supplied to charge the battery whenever needed. The charger can be mounted on a wall surface or placed on a table.

The charger has a LED (Light Emitting Diode) indicating the status of the battery as described below:

LED	Mode
Yellow	No battery
Yellow	Initiation (10 sec)
Orange	Fast charge
Green/yellow	Top-off charge
Green	Trickle charge
Orange/green	Error



Place the battery in the charger. After a few seconds the LED will change from yellow to orange, indicating that the battery is charging. When the LED gives a constant green light the battery is fully charged.

Battery capacity

A Battery LED is situated on the battery holder on the lift. If the voltage of the battery falls below a certain level, the diode will change to orange, indicating the need for charging. There is still enough capacity to perform 3-5 lift cycles (75 kg) at this point.

i If the battery is discharged during a lift, it is always enough power to lower the user down again.

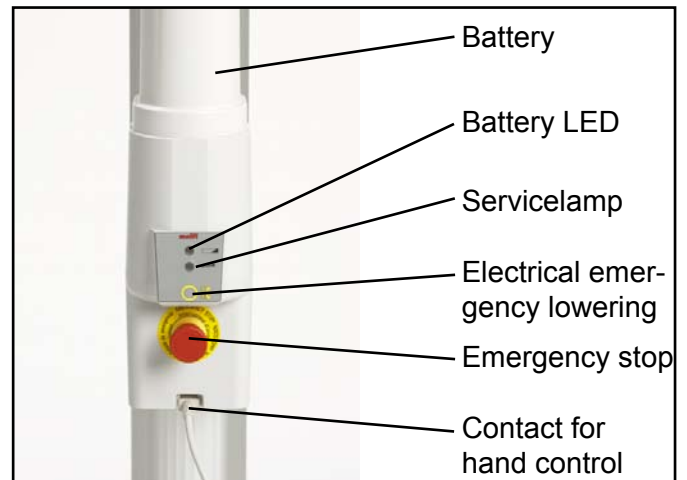

Operating the hand control

The hand control to Molift Partner 230E has four buttons, two buttons for up and down, and two buttons for adjusting the adjustable legs. In addition there is a green diode which illuminates when the battery needs charging.

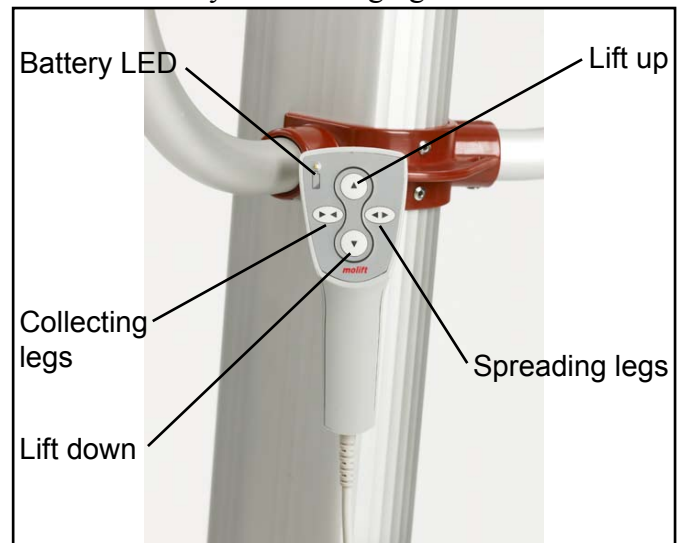

Emergency stop and lowering

Emergency stop

All of the Molift patient lifts are equipped with emergency stop and lowering. The emergency stop button is situated on the battery holder. Push the red button to cut the power to the motor. Turn the button clockwise until it pops up to reset the emergency stop.

Emergency lowering

It is possible to perform an emergency lowering in case of a general malfunction. Molift Partner 230E has both an electrical and manual emergency lowering.



Electrical emergency lowering is placed on the battery holder. Push the button and hold until the patient is lowered.

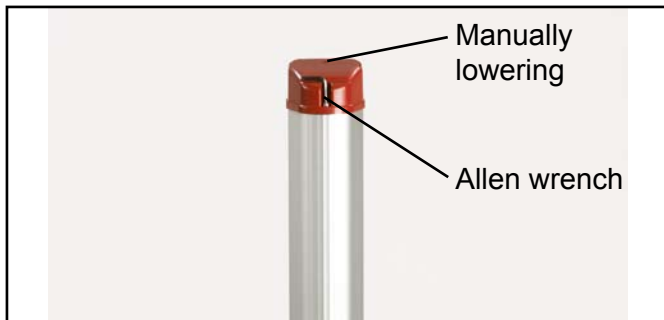



There is an allen wrench situated on the top of the column for the purpose of manually lowering. Push the allen wrench through the hole on the top of the column, and turn until the patient is lowered down.

 *Contact the Molift service partner if the reason for the failure causing an emergency lowering is unknown or if it is a result of failed components or parts.*

Lift and transfer

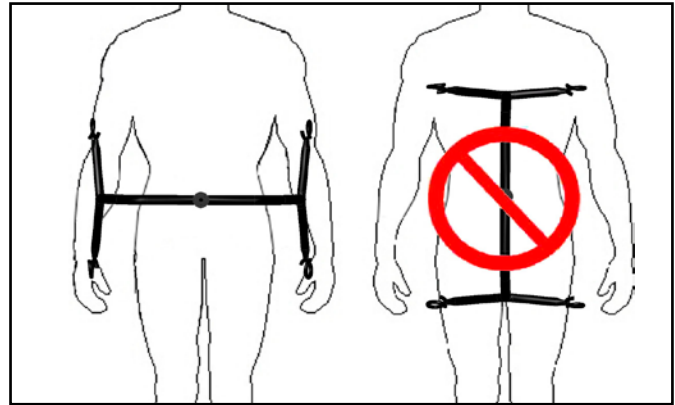
The suspension shall always be positioned across the user as shown left in the illustration below.



 *When using slings intended for two point suspension, the suspension shall be used diagonally, i.e. loops from the sling shall be fastened on hooks diagonally opposite.*

 *Pay close attention to your actions. Ensure that all four loops of the sling are securely fastened to avoid the user slipping or falling.*

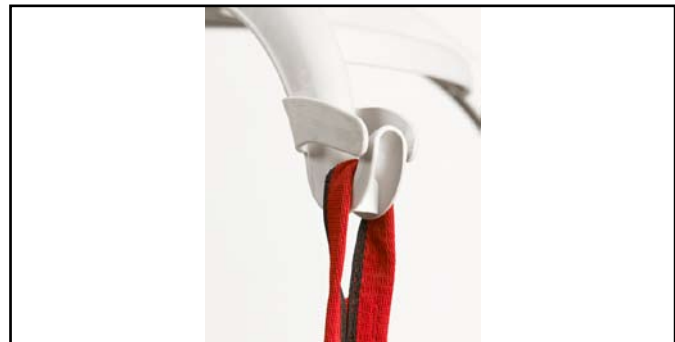

Try to position the user as low as possible (preferably resting the feet on the chassis) when transferring the lifter with a suspended user. In this way, the centre of gravity will be as low as possible and therefore reducing the risk of instability. The lifter should be manoeuvred with spread legs in outer position to achieve the highest possible stability.

Be careful during movement - the suspended user may swing somewhat during turns, stops and starts. Be particularly careful when manoeuvring close to furniture to prevent the suspended user from colliding with these objects.

 *The lifter shall not be used to lift or move users on sloping surfaces.*

 *Please read the user manual that comes with the sling for specific user instructions.*

Avoid deep pile carpets, high thresholds, uneven surfaces or other obstacles that may block the castors. The lifter may become unstable if forced over such obstacles increasing the risk of tipping over.

Sling without head support

 *The lifter shall only be used for movement over short distances. It is not a replacement for wheelchair or similar.*

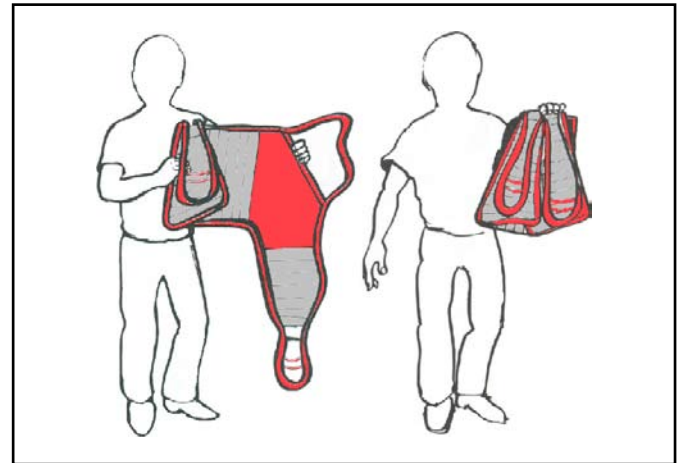

Use of spread legs

Use wide legs wherever appropriate, for instance to position the lifter around wheelchairs, toilets etc.

Using lifting slings

The Easy lifting slings are, as the name indicates, easy to use. They are washable at 80° C and autoclave at 85 °C for 30 minutes.

Sling with head support

 *It is recommended to use Molift slings. Slings from other manufacturers may have other specifications leading to unexpected instability and possible personal injury.*

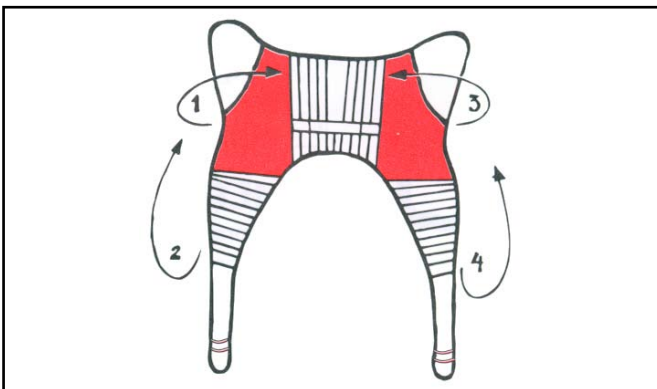
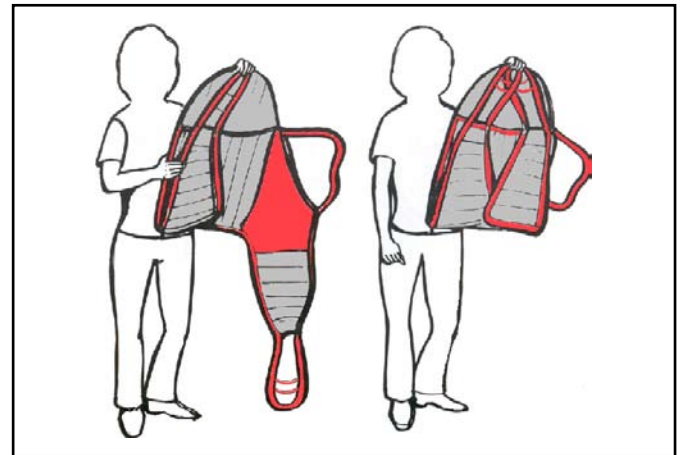

Fold the sling as indicated above before use. The grey side should be facing away from the user when putting the sling in place. The sling should be held by one hand, leaving the other free to move and support the user.

 *Torn, cut, frayed or broken slings can fail, resulting in serious injury to the user. Use slings in good condition only. Destroy and discard old, unusable slings.*

Lift and movement to and from bed

Lift from bed



Roll user onto her side. Put the folded sling behind her back. The centre of the sling should be parallel with the users spine. Roll her then onto her back.

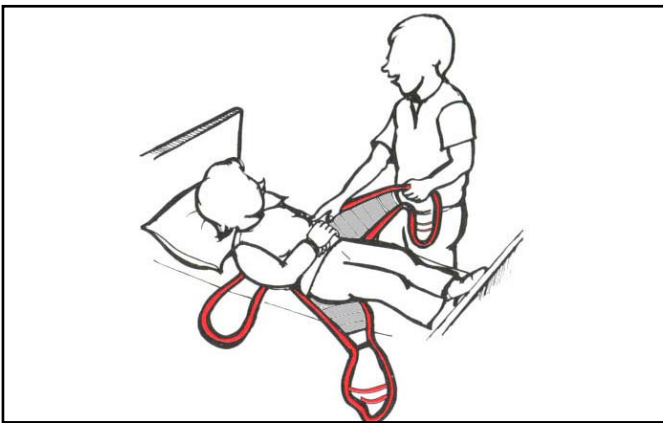

Pull the leg loops forward and under the thighs as shown in illustration above.

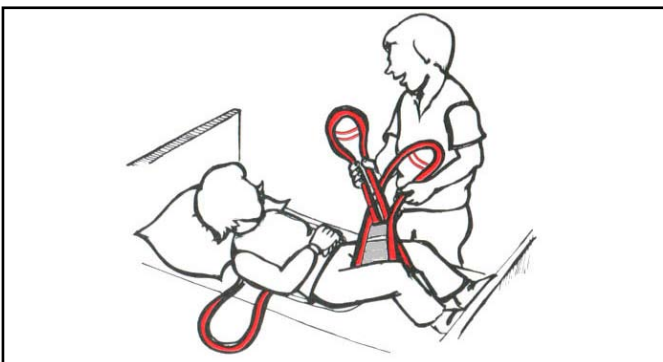

Cross the loops one through the other.

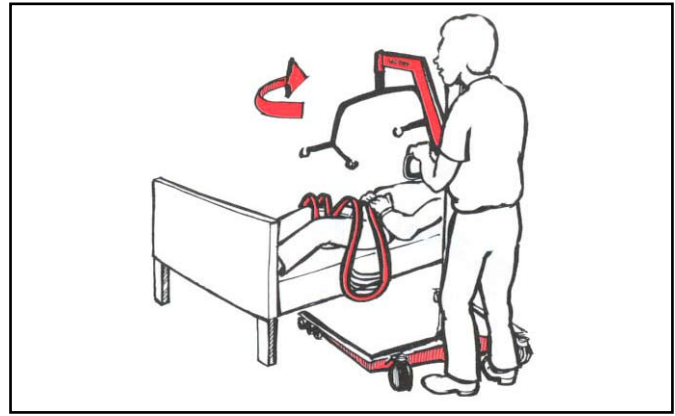

i If the user has a bed which enables raising and lowering, it should be lowered before the lifting starts.

Position the legs under the bed with the suspension over the user. Be careful not to lower the suspension too low touching the user. Make sure that the suspension is centred over the user before you start the lifting. Remember - the castors should not be locked.



When all four loops are hooked onto the suspension, raise the user carefully.

! Pay close attention to your actions. Ensure that all four loops of the sling are securely fastened to avoid the user slipping or falling

i If the user is in a hospital bed, it will help to raise the head of the bed

Repositioning of the user may be needed to ensure that a safe and comfortable sitting position is attained as the user is raised. Reposition using the handle on the back of the sling.

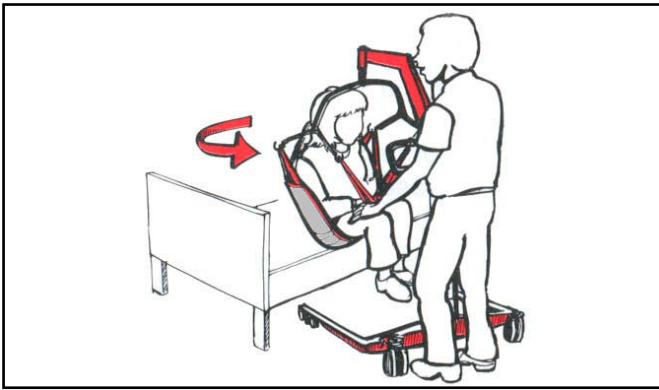

Raise the user until the buttocks are just above the mattress. Lift the user's legs and turn her so she faces the lifting column. When clear of bed, and if practical, lower the user so that her feet rest on the chassis. If possible, lower the bed before lifting. Move the lifter away from bed.

 *Beware of obstructions under the bed that can cause castors to stop or tip.*

Lift to bed



Raise the user until the buttocks are just above the mattress. Position the lifter under the bed.

 *Beware of obstructions under the bed that can cause castors to stop or tip. Take care not to squeeze the users legs.*

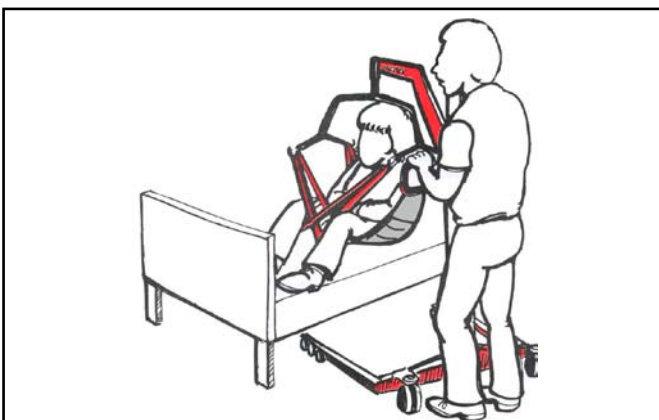

Centre the user over the bed and turn her/him so that the feet point to the end of the bed. Lower the user carefully. Remove the loops from the suspension.

Removing the sling

Gently pull the leg section to the side, out from the user's thighs and towards yourself. Pull the shoulder section under the neck of the user and roll her gently onto her side. Pull the sling away and roll her onto her back.

 *Be careful when rolling the user onto her side. Make sure you have control over the movement to prevent her from rolling completely over and out of the bed.*

Lift and transfer to and from floor

Lift and transfer from the floor is almost identical to a lift and transfer from bed - please read this section. There are two ways to lift from the floor.

Alternative lift 1

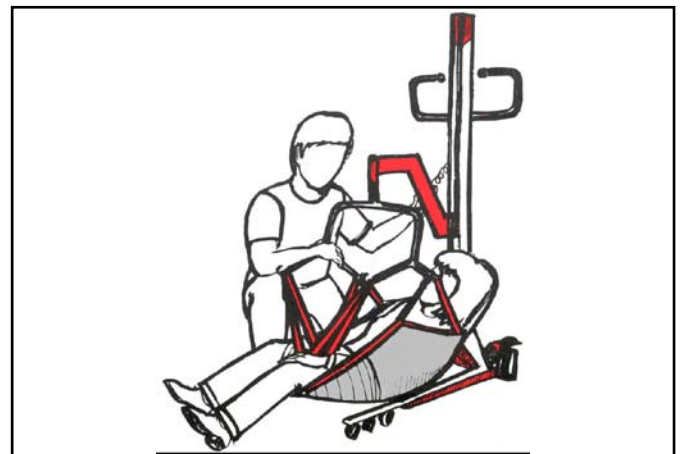

Place the users head on the chassis. Use a pillow if appropriate to protect the head and neck of the user. The suspension shall be centred over the user.

Lower the suspension enough to allow the sling loops to be hooked up.

Raise the user from the floor. Position user in the sling by pulling the handle on the back of the sling. Turn the user to face the lifting column, and place the feet on the chassis.

Alternative lift 2

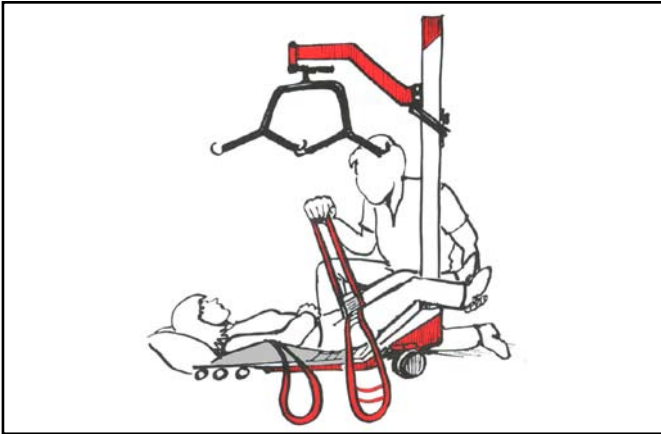

A floor based lift can also be performed by positioning the lifting column between the legs of the user as shown above. Otherwise as alternative 1.

Lowering to floor



Place a pillow on the chassis or on the floor to protect the users head and neck (not necessary if you are using a sling with head support). Otherwise as described above.

Lift and transfer to and from (wheel) chair

Lift and transfer from (wheel) chair

Fold the sling as described in “Using lifting slings”. The gray side should be turned away from the user when placing the sling.



i If the users physique and ability allows it, the user should be encouraged to take active part in fitting the sling. The user can lean forward, lift her thighs and help placing the leg section.

Lean the user forward gently, but ensure you continue to support her. Place the folded sling behind the user’s back and push it down until it touches the **seat of the chair**.

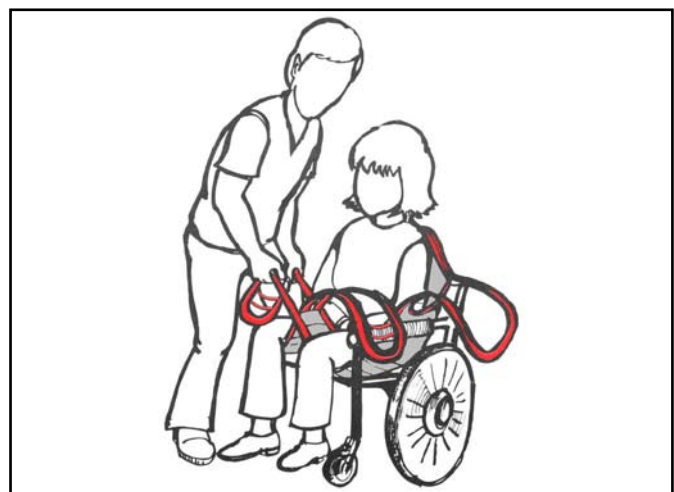

The leg sections of the sling are pulled forward and beneath the user’s thighs by the loops. The loops are then crossed, one through the other, as shown.

 *Pay close attention to your actions. Ensure that all four loops of the sling are securely fastened to avoid the user slipping or falling*



Move the lifter around the chair, and let the user rest her feet on the chassis.

 *If the transfer is from a wheelchair, the brakes must be locked to prevent the wheelchair from rolling away.*

Lift/raise the user above seat height, and perform the transfer. It is not necessary to lift the person very high.

Lift and transfer to (wheel) chair

Manoeuvre the lifter so that the user is as far back in the (wheel) chair as possible.

 *If the transfer is from a wheelchair, the brakes must be locked to prevent the wheelchair from rolling away.*

When lowering, you can use the following techniques or a combination of them to position and get the user seated far back in the chair:

- push gently on the knees
- pull the loop on the back of the sling
- tilt the chair slightly backwards

Lower the user into the chair, unhook sling from suspension and remove the lifter.

Removal of sling

Gently pull leg section to the side, out from the user's thighs. Standing by the side of the user, lean her forward - supporting with one hand. Pull sling up from behind her back.



 *Pulling sharply on sling may cause user to fall forward resulting an injury. Always support the user by keeping one arm around the user's shoulder when fitting or removing the sling (see illustration).*

 *If the users physique and ability allows it, the user should be encouraged to take active part in fitting the sling. The user can lean forward, lift her tights and help placing the leg section.*

Bathing

The procedure for lifting to/from the bath is in principle the same as for to/from bed. A special bathing sling is used for this purpose. This sling dries quickly and may be washed at 80 °C.

Toileting

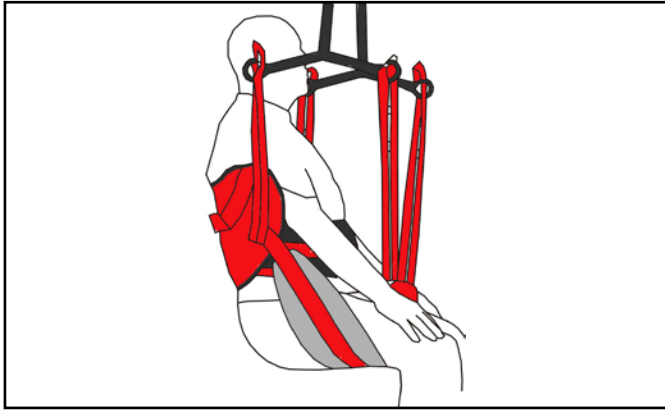

The Easy Toilet Sling is used with the standard 4-point suspensions.

i *Easy Toilet sling is a toilet sling with a thicker and wider upholstery. It is also available with head-support. The Molift Easy Toilet Comfort sling is easier to fit in narrow environments, and is available with a separate head support*

The toilet sling can be washed at 80 °C, and is fitted as follows:

- Insert the sling behind the users back with the grey side away from user.
- Fasten the belt firmly around the user's body.
- Place the leg section under the front part of the thighs and pull the loops up between the thighs. On Molift Easy Toilet Comfort, place the leg section over and down between the thighs and pull outwards from the inner part of the thighs.



i *The leg sections of Molift Easy Toilet Comfort Sling are fitted to separate the legs, therefore they should not be crossed as the other Easy slings.*

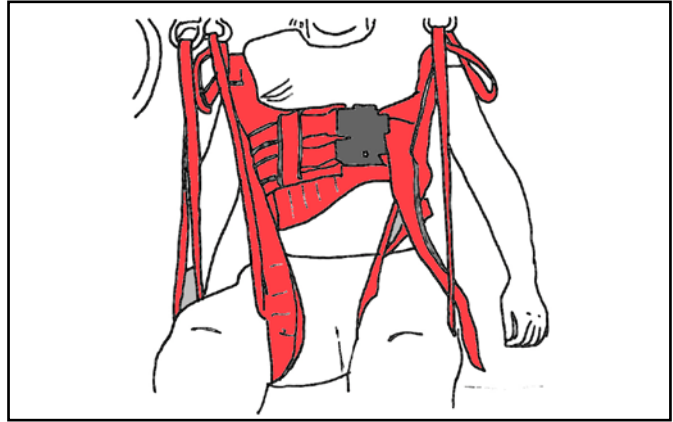

- Hook the four loops on the suspension as for other slings.
- Position the lifter around the toilet and lower the user.
- Pull the leg sections out of the way. The sling can be left on during bathroom use.

Alternative

i *By pulling the leg sections from the outside and in, you will achieve a wider leg position.*

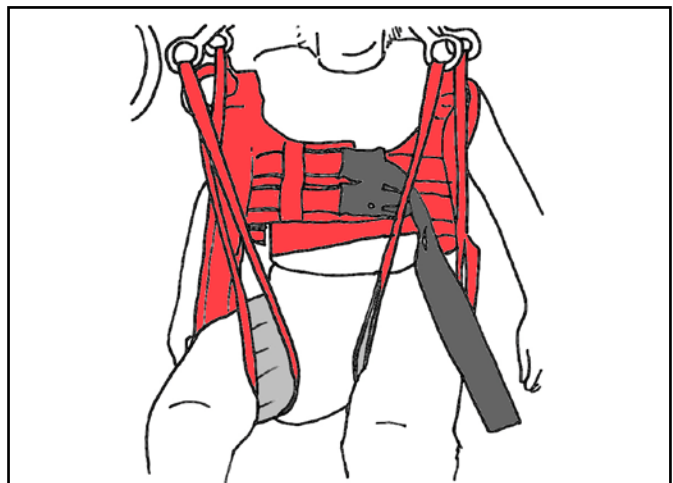

Accessories

Lifting sling

Molift Easy Paediatric Sling

Size	No head support	With head support
XXS	Art. no 3005050	Art. no 3006050
XS	Art. no 3005000	Art. no 3006000

Easy Toilet Sling and Basic Bathing Sling for kids, see the tables below, size XXS and XS.

Molift Easy Sling

Size	No head support	With head support
XS	Art. no 3025000	Art. no 3026000
S	Art. no 3025100	Art. no 3026100
M	Art. no 3025200	Art. no 3026200
L	Art. no 3025300	Art. no 3026300
XL	Art. no 3025400	Art. no 3026400
XXL	Art. no 3025500	Art. no 3026500

Molift Basic Sling

Size	No head support	With head support
XXS	Art. no 3021050	Art. no 3022050
XS	Art. no 3021000	Art. no 3022000
S	Art. no 3021100	Art. no 3022100
M	Art. no 3021200	Art. no 3022200
L	Art. no 3021300	Art. no 3022300
XL	Art. no 3021400	Art. no 3022400
XXL	Art. no 3021500	Art. no 3022500

Molift Basic Bathing Sling

Size	No head support	With head support
XXS	Art. no 3023050	Art. no 3024050
XS	Art. no 3023000	Art. no 3024000
S	Art. no 3023100	Art. no 3024100
M	Art. no 3023200	Art. no 3024200
L	Art. no 3023300	Art. no 3024300
XL	Art. no 3023400	Art. no 3024400
XXL	Art. no 3023500	Art. no 3024500

Molift Easy Toilet Sling

Size	No head support	With head support
XXS	Art. no 3032050	Art. no 3033050
XS	Art. no 3032000	Art. no 3033000
S	Art. no 3032100	Art. no 3033100
M	Art. no 3032200	Art. no 3033200
L	Art. no 3032300	Art. no 3033300
XL	Art. no 3032400	Art. no 3033400
XXL	Art. no 3032500	Art. no 3033500

Molift Easy Toilet Sling Comfort

Size	No head support	Separate head support
XXS	Art. no 3016050	Art. no 3016055
XS	Art. no 3016000	Art. no 3016001
S	Art. no 3016100	Art. no 3016111
M	Art. no 3016200	Art. no 3016222
L	Art. no 3016300	Art. no 3016333
XL	Art. no 3016400	Art. no 3016444
XXL	Art. no 3016500	Art. no 3016555

Molift Easy Amputee Sling

Size	No head support	With head support
XXS	Art. no 3027050	Art. no 3028050
XS	Art. no 3027000	Art. no 3028000
S	Art. no 3027100	Art. no 3028100
M	Art. no 3027200	Art. no 3028200
L	Art. no 3027300	Art. no 3028300
XL	Art. no 3027400	Art. no 3028400
XXL	Art. no 3027500	Art. no 3028500

Sling size guide

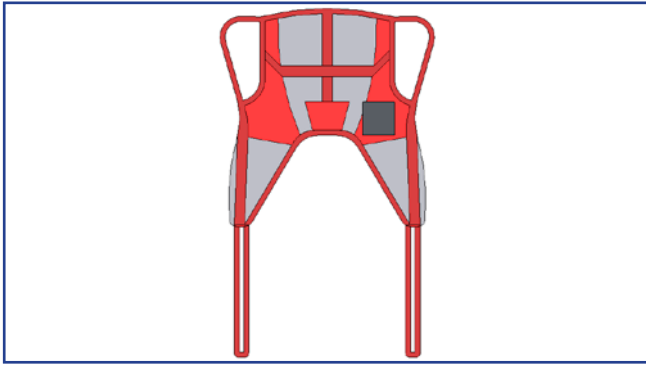

Easy and Basic Slings

Size	Color code	Recomm. weight (Kg)	A (cm)	B (cm)	C (cm)
XXL	White	230-300	86	130	68
XL	Blue	160-240	76	115	66
L	Green	90-160	66	100	64
M	Yellow	45-95	56	85	62
S	Red	25-50	51	75	60
XS	Light blue	17-25	46	65	58
XXS	Pink	12-17	41	55	56

Choice of sling size depends on both user weight and shape/size of user.

Bag for slings - Part. no 3048000

Padding for suspension - Part no 1330114

Maintenance

Daily maintenance

 *Detergents must be pH-neutral. Do not use solvents or strong liquids - this may damage surfaces on the lifter and change the quality of the material. For disinfection when needed; use isopropyl alcohol. Avoid abrasive or etching cleaning products.*

Clean surfaces with a damp cloth using an appropriate detergent.

 *Make sure that there is no damage or cracks on supporting parts. The suspension shall not be used if there are any visible damages or cracks as it may cause personal injury or damage to the lifter.*

Monthly maintenance

- Check the lifter, and the suspension especially, for damage. Make sure there is no loose parts on the lifter
- Remove hair and pile from the castors and verify that the castors rotates without abnormal friction
- Verify that the contacts of the hand control is firmly in place, and that the battery fits correctly in the battery holder.
- Clean contact and hand control with spirit or similar to remove grease and dirt
- Verify that the cables for the hand control and charger are intact
- Run the lifter up and down, and legs in and out to verify that it runs normally and without any abnormal noise.

Service / yearly maintenance

Molift Partner 230E has a LED on the battery holder indicating if the lifter needs service. The LED gives a green light when the lifter is ready for use.

The electronics has a power save-function which makes the system sleep after a while with no activity. All lights will go out. Activate the system by pushing one of the buttons on the hand control.

The electronics logs how much the lifter is being used, and the load it is used with. After a given time of usage there will be given a signal that the lifter needs service to the service LED. The LED will first give a yellow light, then red. Take contact with your local service representative and order service. If there is a sound together with the light, it means the lifter needs service immediately.

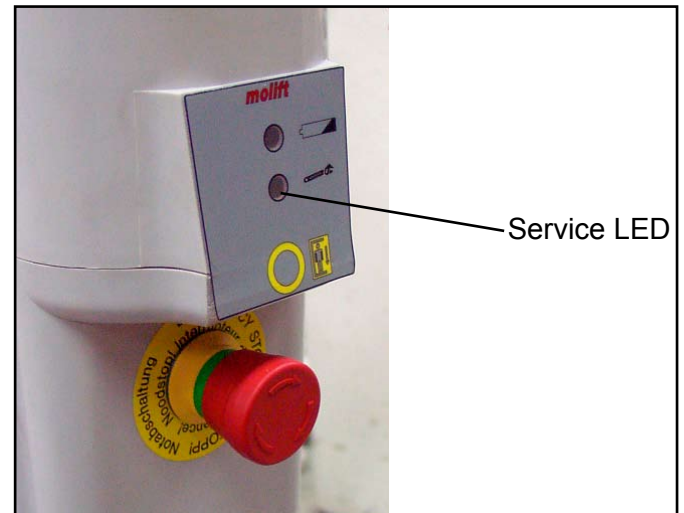

Service lamp	Status
No light	Power save
Green	Ready for use
Yellow	Order service, lifter still works
Red	Perform service
Red + sound	Perform service immediately
Flashing yellow	Overheating

If the lifter is run up and down constantly for a longer period, the electronics may be overheated and the lifter will stop. The service LED will flash until the lifter is cooled down enough for further use. The service LED will go out when the lifter is ready for use.

If you are not able to solve the fault or problems by yourself using this manual, please contact local authorised service representative. If you do not know whom to contact locally, please contact your dealer or Molift AS to get help.

Molift recommends yearly service on the lifter. Service is done by an authorised service representative according to procedures in the technical manual. The service partner uses the Molift Service Tool to read the data from the lifter, and for logging service and resetting the service LED. The owner is responsible to ensure proper logging and written verification performed by authorised service partner.

Troubleshooting

If you have access to other similar lifters, it might be an advantage to “switch parts” in order to locate the error. See the table for troubleshooting:

Symptom	Possible cause/action
The lifting column is wobbly.	The lock handle is not locked properly or the lifting column is out of position in chassis / <i>verify position of lifting column and tighten the lock</i>
The lifter only moves in one direction/ adjustable legs only moves in one direction	Hand control has failed / <i>test with another hand control and change if defective.</i>
	The control electronics has failed / <i>change control electronics / contact local representative for service</i>
The lifter moves uncontrolled / adjustable legs moves uncontrolled	Short circuit between hand control and lifter / <i>clean the contact to hand control with spirit to remove grease</i>
	Hand control has failed / <i>change hand control / contact local representative for service</i>
	Defective control electronics / <i>change control electronics / contact local representative for service</i>

The lifting arm does not move / adjustable legs does not move	Emergency stop activated (button is pressed in) / <i>turn button counter clockwise to reset</i>
	Battery is empty / <i>change to a new battery or charge battery</i>
	The motor connection is not in contact / <i>Reposition the lifting column, use the allen wrench on top of column and check the arrow towards chassis (see page 7), clean contact points on column and chassis</i>
	The cable/contact to hand control has disconnected / <i>reconnect contact</i>
	Hand control has failed / <i>test with another hand control and change if defective / contact local representative for service</i>
	Defective control electronics / <i>change control electronics / contact local representative for service</i>
	Motor is defective / <i>change motor / contact local representative for service</i>

molift[®]

WARRANTY

Molift AS hereby declares that this product is awarded up to 5 - five - year extended manufacturer's warranty.

It is very important to our customers and to Molift AS that our products meet all relevant quality and safety requirements according to both customer and authority demands. Molift AS develops and manufactures products with high standards of safety, quality and design, and we are continuously in a process of keeping our products in position among the market leaders.

To make our products quality level more explicit Molift AS have introduced extended warranty time on all of our patient lifters. A 5 - five - year* warranty against defects which might be traced back to manufacturing is offered. The extended warranty period is offered under the condition that the regulations described here are completely fulfilled and that the product has been used according to its intentions. The extended warranty is valid for a period of 5 - five - years starting at the date of purchase limited to 3 months after the production year/week. The extended warranty is offered in addition to the local sale of goods act. It is mandatory that the product undergoes safety control and maintenance performed by an authorised service partner at least every 12 months according to this service manual made by Molift AS.

- Yearly maintenance and safety control must be performed within a maximum interval of 12 months and for the first time maximum 12 months after date of purchase or maximum 15 months after year/ week of production.
- Molift AS will cover the cost of spare parts and labour in the warranty period for all necessary repairs caused by product defects that can be traced back to manufacturing. The repair must be performed by an authorised service partner or at Molift AS' own workshop during the warranty period.
- All warranty repairs must be approved by your Molift supplier or by Molift AS prior to the repair.
- The owner of the product is responsible for establishing the service agreement, and the cost for the annual safety control and maintenance.
- The service manual has one page for every 12 months containing checkpoints for maintenance and safety control. The extended warranty is valid only with signature and/or stamp by authorised service partner including service partner's signed label with authorisation no. on product.

* Normal warranty is 12 months. This still applies for slings, hand control, batteries and paint.

Gjøvik 28.08.2006

Molift AS



Geir Olav Farstad
Managing Director

molift®

DECLARATION OF CONFORMITY



Molift AS
Ole Deviksvei 44
0668 OSLO
NORWAY
Telephone: + 47 40 00 10 04

hereby declare that:

Molift PARTNER 230E patient lifter
and that the accessoires used only together with this product

Year: 2006

are in conformity with:

- The Council Directive concerning medical devices (93/42/EØF)
and according to this classified as **medical equipment class 1**

Molift PARTNER 230E is manufactured in conformity with the following national or international standards that also might implement a harmonised standard:

- ISO10535 Hoists for the transfer of disabled persons - Requirements and test methods
 - ISO 14971 Medical equipment - Risik analysis

Notified fody:

Title: Managing Director
Name: Geir Olav Farstad
Company: Molift AS

28.08.2006

Date

Signature



At times with increasing demand for efficiency in the healthcare sector and growing focus on patients needs, it is easy to neglect the needs of the carer. The need to give better help and caring avoiding heavy lifting situations, avoiding putting your own back at risk, without being completely exhausted after work and still have some surplus energy when the workday is over.

This is the insight that drives us at Molift. The company was started 20 years ago by a man who through his own experience saw the need for lifting and moving patients in an effective and comfortable way - for both patient and carer.

We have since then delivered products that compliment the natural movements of the body, that is both simple and intuitive to use. Products designed to give the patient a better life in addition to providing the carer with real support and optimum work enjoyment.

This is the true meaning of; Molift - designed for life

Molift AS

Ole Deviksvei 44

N - 0668 OSLO

Norway

Telephone: (+47) 4000 1004

Fax: (+47) 4000 1008

www.molift.com

info@molift.com

molift[®]
designed for life