

Model:
SL-350TRS-CE-D

Installers Guide

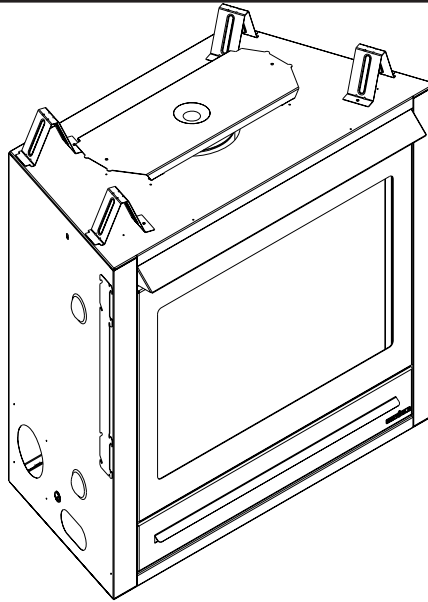

WARNING:
IF THE INFORMATION IN THESE INSTRUCTIONS IS NOT FOLLOWED EXACTLY, A FIRE OR EXPLOSION MAY RESULT CAUSING PROPERTY DAMAGE, PERSONAL INJURY, OR DEATH.

- Do not store or use petrol or other flammable vapors and liquids in the vicinity of this or any other appliance.
- **What to do if you smell gas**
 - Do not try to light any appliance.
 - Do not touch any electrical switch.
 - Do not use any phone in your building.
 - Immediately call your gas supplier from a neighbor's phone. Follow the gas supplier's instructions
 - If you cannot reach your gas supplier, call the fire department.
- Installation and service must be performed by a qualified installer or competent person.

READ THIS MANUAL BEFORE INSTALLING OR OPERATING THIS APPLIANCE. THIS *INSTALLERS GUIDE* MUST BE LEFT WITH APPLIANCE FOR FUTURE REFERENCE.

WARNING: IMPROPER INSTALLATION, ADJUSTMENT, ALTERATION, SERVICE OR MAINTENANCE CAN CAUSE INJURY OR PROPERTY DAMAGE. REFER TO THIS MANUAL. FOR ASSISTANCE OR ADDITIONAL INFORMATION CONSULT A QUALIFIED INSTALLER OR COMPETENT PERSON.

These instructions are only valid if the following country symbol is on the appliance. If this symbol is not present on the appliance, it is necessary to refer to the technical instructions which will provide the necessary information concerning the modification of the appliance to the conditions of use for the country.

These instructions are valid for the following countries: GB, IE

Printed in U.S.A. Copyright 2007
Heat & Glo, a brand of Hearth & Home Technologies Inc.
20802 Kensington Blvd., Lakeville, MN 55044

Please contact your Heat & Glo dealer with any questions or concerns. For the number of your nearest Heat & Glo dealer, please call 1-888-427-3973.

This product is covered by one or more of the following patents: (United States) 4,112,913; 4,408,594; 4,422,426; 4,424,792; 4,520,791; 4,793,322; 4,852,548; 4,875,464; 5,000,162; 5,016,609; 5,076,254 5,191,877; 5,218,953; 5,328,356; 5,429,495; 5,452,708; 5,542,407; 5,613,487; (Australia) 543790; 586383; (Canada) 1,123,296; 1,297,746; 2,195,264; (Mexico) 97-0457; (New Zealand) 200265; or other U.S. and foreign patents pending.

SAFETY AND WARNING INFORMATION



READ and **UNDERSTAND** all instructions carefully before starting the installation. **FAILURE TO FOLLOW** these installation instructions may result in a possible fire hazard and will void the warranty.



Prior to the first firing of the stove, **READ** the Using Your Fireplace section of the *Users Guide*.



DO NOT USE this appliance if any part has been under water. Immediately **CALL** a qualified service technician to inspect the unit and to replace any part of the control system and any gas control which has been under water.



THIS UNIT IS NOT FOR USE WITH SOLID FUEL.



Installation and repair should be **PERFORMED** by a qualified service person. The appliance and flue system should be **INSPECTED** before initial use and at least annually by a professional service person.



Always **KEEP** the appliance clear and free from combustible materials, petrol, and other flammable vapors and liquids.



NEVER OBSTRUCT the flow of combustion and ventilation air. Keep the front of the appliance **CLEAR** of all obstacles and materials for servicing and proper operations.



Due to the high temperature, the appliance should be **LOCATED** out of traffic areas and away from furniture and draperies. Clothing or flammable material **SHOULD NOT BE PLACED** on or near the appliance.



Children and adults should be **ALERTED** to the hazards of high surface temperature and should **STAY AWAY** to avoid burns or clothing ignition. Young children should be **CAREFULLY SUPERVISED** when they are in the same room as the appliance.



These units **MUST** use one of the fluing systems described in the Installing the Fireplace section of the *Installers Guide*. **NO OTHER** flue systems or components **MAY BE USED**.



This gas stove and flue assembly **MUST** be vented directly to the outside and **MUST NEVER** be attached to a chimney serving a separate solid fuel burning appliance. Each gas appliance **MUST USE** a separate flue system. Common flue systems are **PROHIBITED**.



INSPECT the external terminal cap on a regular basis to make sure that no debris is interfering with the air flow.



The glass door assembly **MUST** be in place and sealed, and the trim door assembly **MUST** be in place on the stove before the unit can be placed into safe operation.



DO NOT OPERATE this appliance with the glass door removed, cracked, or broken. Replacement of the glass door should be performed by a licensed or qualified service person. **DO NOT** strike or slam the glass door.



The glass door assembly **SHALL ONLY** be replaced as a complete unit, as supplied by the gas stove manufacturer. **NO SUBSTITUTE** material may be used.



DO NOT USE abrasive cleaners on the glass door assembly. **DO NOT ATTEMPT** to clean the glass door when it is hot.



Turn off the gas before servicing this appliance. It is recommended that a qualified service technician perform an appliance check-up at the beginning of each heating season.



Any safety screen or guard removed for servicing must be replaced before operating this appliance.



This appliance is intended for use on a gas installation with a governed meter.

Table of Contents

Safety and Warning Information	2
Service Parts List	4
Section 1: Approvals and Regulations	7
Appliance Certification	7
Installation Regulations	7
Section 2: Getting Started	8
Introducing the Heat & Glo Gas Fireplaces	8
Pre-installation Preparation	8
Section 3: Installing the Fireplace	10
Step 1 Locating the Fireplace	10
Step 2 Framing the Fireplace	11
Step 3 Installing the Flue System	12
A. Flue System Approvals	12
B. Installing Flue Components.....	23
C. Flue Termination	26
Step 4 Positioning, Leveling and Securing the Fireplace	31
Step 5 The Gas Control Systems	31
Step 6 The Gas Supply Line	32
Step 7 Gas Pressure Requirements	33
Step 8 Wiring the Fireplace	33
Step 9 Finishing	34
Step 10 Installing Trim, Logs & Ember Material	35
Installing the Trim	35
Positioning the Logs	36
Placing the Ember Material	38
Step 11 Before Lighting the Fireplace	39
Step 12 Lighting the Fireplace	39
After the Installation	39
Section 4: Maintaining and Servicing Your Fireplace	40
Section 5: Troubleshooting	42

➔ = Contains updated information.

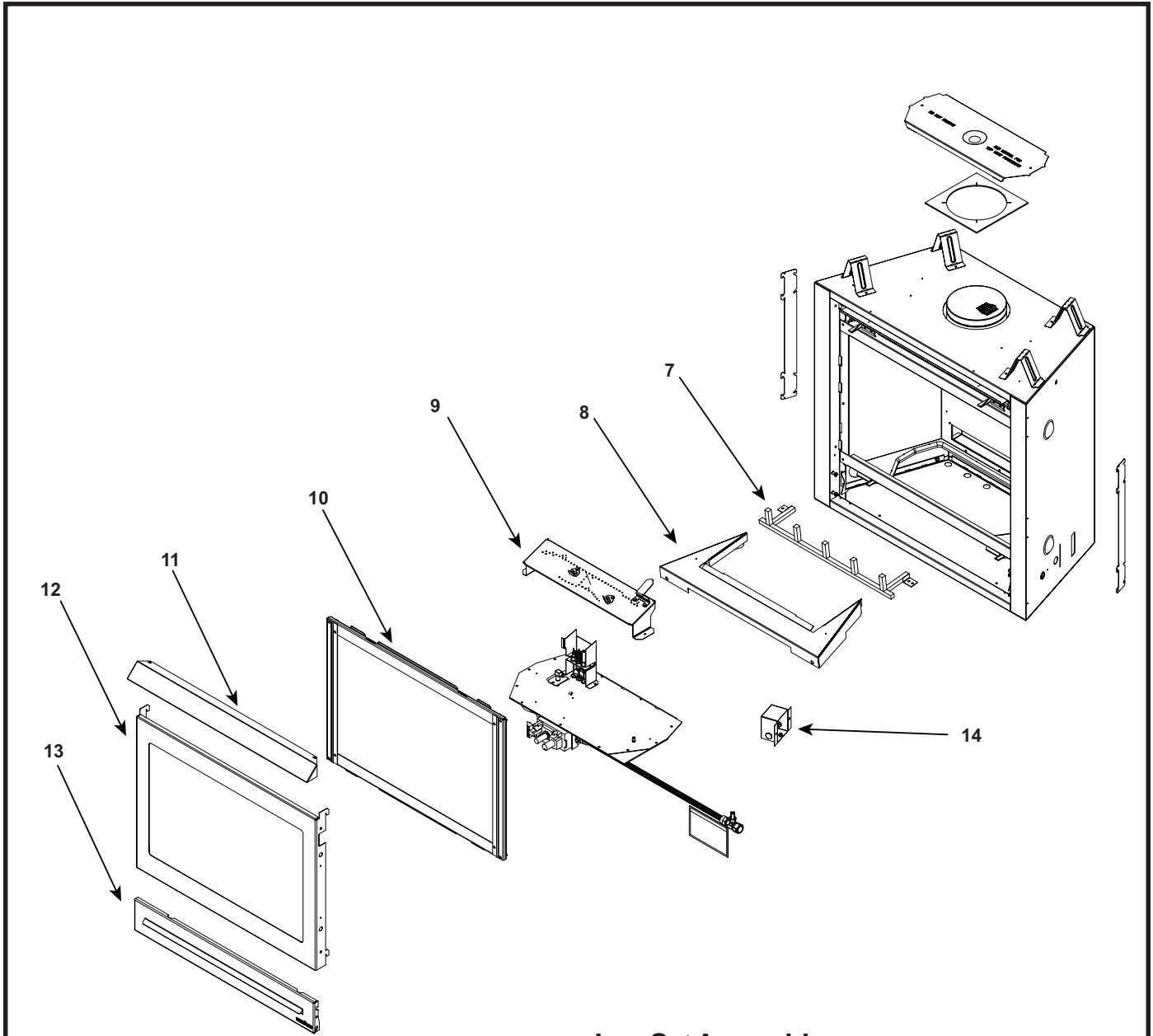

Log Set Assembly



Part number list on following page.

(NG, LP) Service Parts List**SL-350TRS-CE-D**

IMPORTANT THIS IS DATED INFORMATION. When Requesting service or replacement parts for your appliance, please provide model number and serial number. All parts listed in this manual may be ordered from an authorized dealer.

ITEM	DESCRIPTION	SERIAL #	PART NUMBER
	Log Set Assembly		LOGS-350CE-D
1	Log 1		SRV327-701
2	Log 2		SRV2033-701
3	Log 3		SRV705-703
4	Log 4		SRV530-716
5	Log 5		SRV438-724
6	Log 6		SRV540-704
7	Grate Assembly		2033-013
8	Base Pan		2033-105
9	Burner N	Pre Sept 2007	2033-007
		Post Sept 2007	2033-027
	Burner P	Pre Sept 2007	2033-008
		Post Sept 2007	2033-028
	Burner B	Pre Sept 2007	2033-009
		Post Sept 2007	2033-029
10	Glass Door Assembly	Pre 0021061383	GLA-350TRS
		Post 0021061383	GLA-3504TRS
11	Hood		SRV540-174
12	Door Assembly	Pre 00295123	540-382A
		Post 00295123	2033-020
13	Door Assembly, Lower	Post 00295123	2033-021
14	Junction Box		546-250A
	Louver, Upper	Pre 00295123	540-256A
	Louver, Lower	Pre 00295123	540-257A
	Glass Latch Assembly		386-122A
	Exhaust Baffle		530-299
	Mineral Wool		050-721
	Gasket Assembly		2113-080
	Includes: Burner Neck, Shutter Bracket, Vent, Seal Cap, Valve		
	Plate, and Air Passage Gaskets		
	Touch Up Paint		TUP-GBK-12
	Wall Switch (off White)		WSK-21
	Wall Switch (White)		WSK-21-W
	Conversion Kit N		NGK-350TRSCE-D
	Conversion Kit P		LPK-350TRSCE-D
	Conversion Kit B		BGK-350TRSCE-D
	Pilot Orifice N		529-512
	Pilot Orifice P/ B		200-2630
	Regulator N		230-1570
	Regulator P/B		230-1520

Additional service part numbers may appear on following page.

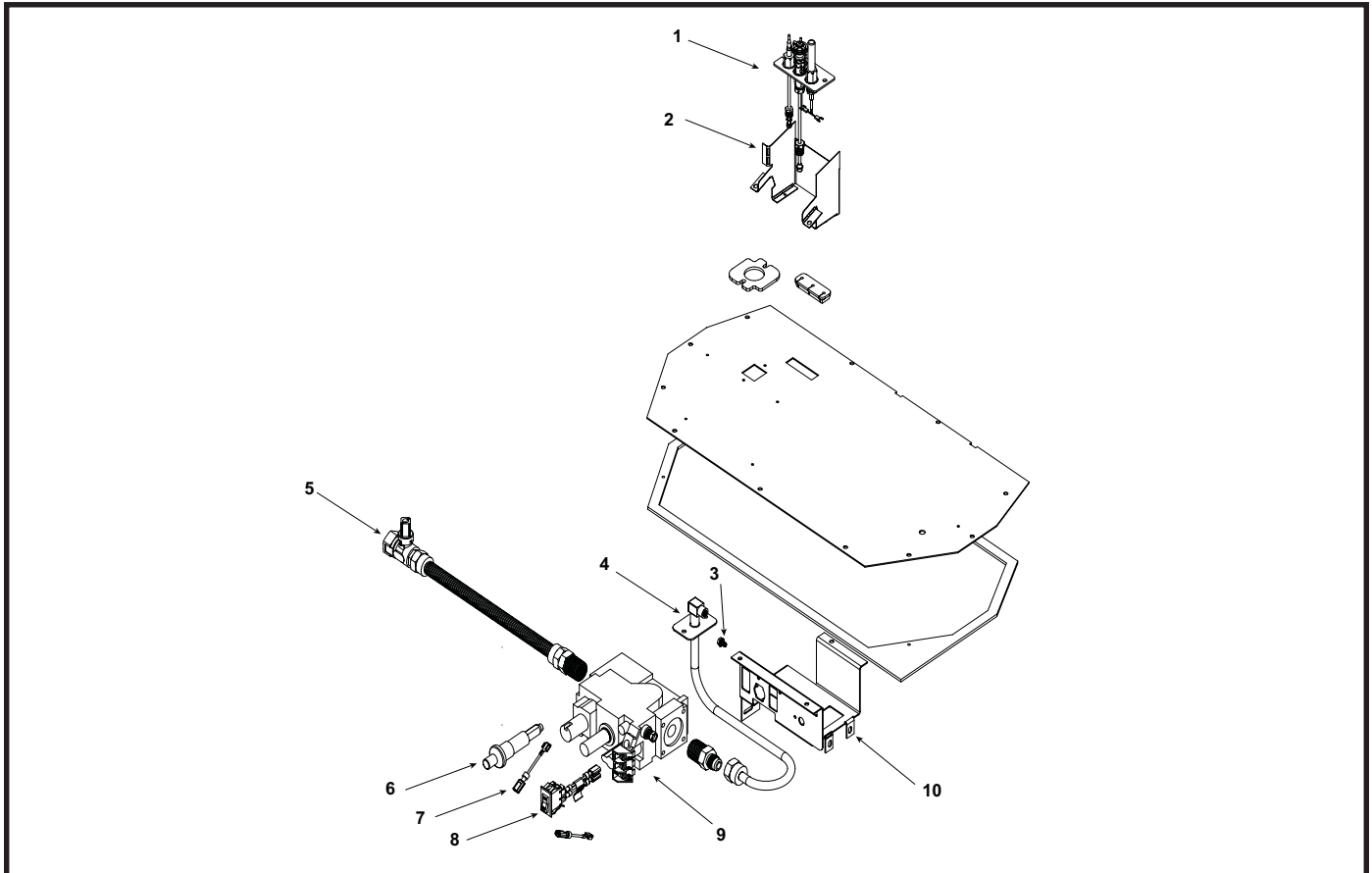

IMPORTANT THIS IS DATED INFORMATION. When Requesting service or replacement parts for your appliance, please provide model number and serial number. All parts listed in this manual may be ordered from an authorized dealer.

ITEM	DESCRIPTION	SERIAL #	PART NUMBER
1	Pilot Assembly N		529-540A
	Pilot Assembly P		529-541A
2	Pilot Bracket	Pre Sept 2007	2033-103
		Post Sept 2007	2033-133
3	Orifice N (#44C)		582-844
	Orifice B (# 56C)		582-856
	Orifice P (#55C)		582-855
4	Flexible Gas Connector		383-302A
5	Flex Ball Valve Assembly		2078-022
6	Piezo Ignitor		291-513
7	Wire Assembly		049-552A
8	On/Off Switch Assembly		060-521A
9	Valve N		060-524
	Valve P		060-526
10	Valve Bracket	Pre Sept 2007	529-169
		Post Sept 2007	2118-104



1

Approvals and Regulations

Appliance Certification

The Heat & Glo fireplace models discussed in this *Installers Guide* have been tested to certification standards and listed by the applicable laboratories.

MODEL	LABORATORY	TYPE	CERTIFICATION STANDARD
SL-350TRS-CE-D	Advantica	Gas Fireplace	90/396/EEC

Installation Regulations

Before installation check that local distribution conditions, nature of gas and pressure, and adjustment of the appliance are compatible.

This appliance must be installed with the rules in force, and used only in a sufficiently ventilated space. Consult instructions before installation and use of this appliance.

Introducing the Heat & Glo Gas Fireplaces

Heat & Glo direct flue gas fireplaces are designed to operate with all combustion air siphoned from outside of the building and all exhaust gases expelled to the outside.

The information contained in this *Installers Guide*, unless noted otherwise, applies to all models and gas control systems.

Gas fireplace diagrams, including the dimensions, are shown in this section.

Pre-installation Preparation

This gas fireplace and its components are tested and safe when installed in accordance with this *Installers Guide*. Report to your dealer any parts damaged in shipment, particularly the condition of the glass. **Do not install any unit with damaged, incomplete, or substitute parts.**

The flue system components and trim doors are shipped in separate packages. The gas logs are packaged separately and must be field installed. **Read all of the instructions before starting the installation. Follow these instructions carefully during the installation to ensure maximum safety and benefit. Failure to follow these instructions will void the owner's warranty and may present a fire hazard.**

The Heat & Glo Fireplace Products, Inc. Warranty will be voided by, and Heat & Glo Fireplace Products, Inc. disclaims any responsibility for, the following actions:

- Installation of any damaged fireplace or flue system component.
- Modification of the fireplace or direct flue system.
- Installation other than as instructed by Heat & Glo Fireplace Products, Inc.
- Improper positioning of the gas logs or the glass door.
- Installation and/or use of any component part not manufactured and approved by Heat & Glo Fireplace Products, Inc., not withstanding any independent testing laboratory or other party approval of such component part or accessory.

ANY SUCH ACTION MAY POSSIBLY CAUSE A FIRE HAZARD.

2

Getting Started

When planning a fireplace installation, it's necessary to determine:

- Where the unit is to be installed.
- The flue system configuration to be used.
- Gas supply piping.
- Electrical wiring.
- Framing and finishing details.
- Whether optional accessories—devices such as a fan, wall switch, or remote control—are desired.

If the fireplace is to be installed on carpeting or tile, or on any combustible material other than wood flooring, the fireplace should be installed on a metal or wood panel that extends the full width and depth of the fireplace.

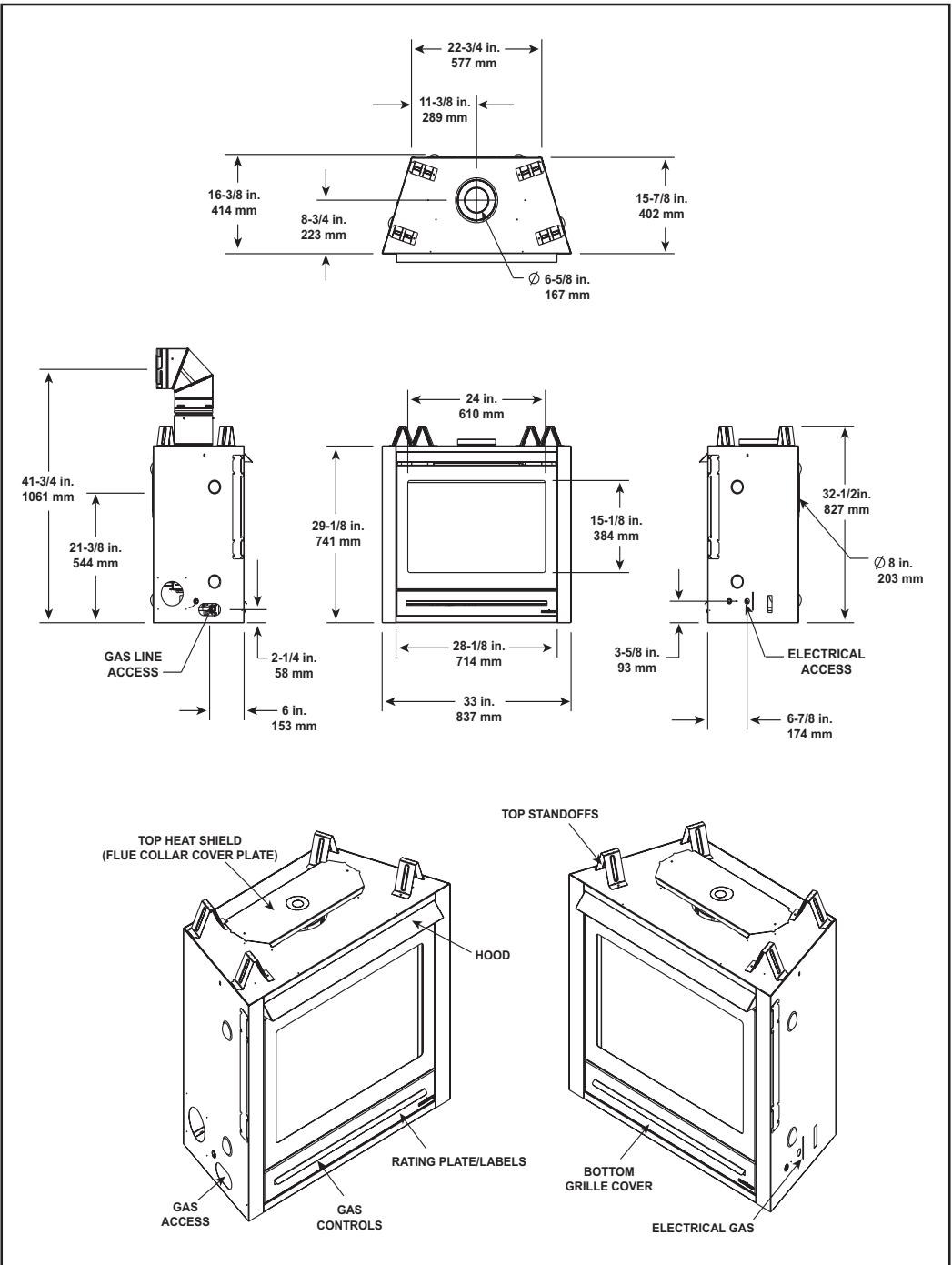

Figure 1. Diagram of the SL-350TRS-CE-D

3

Installing the Fireplace

Step 1 Locating the Fireplace

The diagram below shows space and clearance requirements for locating a fireplace within a room.

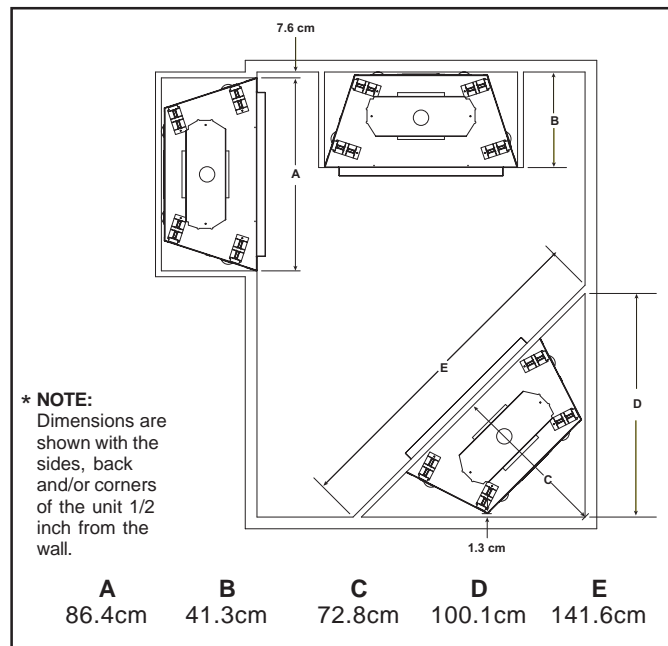

Figure 2. Fireplace Dimensions, Locations, and Space Requirements

Clearance Requirements

The top and back of the fireplace are defined by stand-offs.

The heat shield must be attached as shown if combustible materials are placed directly on top standoffs (Figure 3).

The minimum clearance to a perpendicular wall extending past the face of the fireplace is 7.62cm.

The back of the fireplaces may be recessed into combustible construction, as shown below.

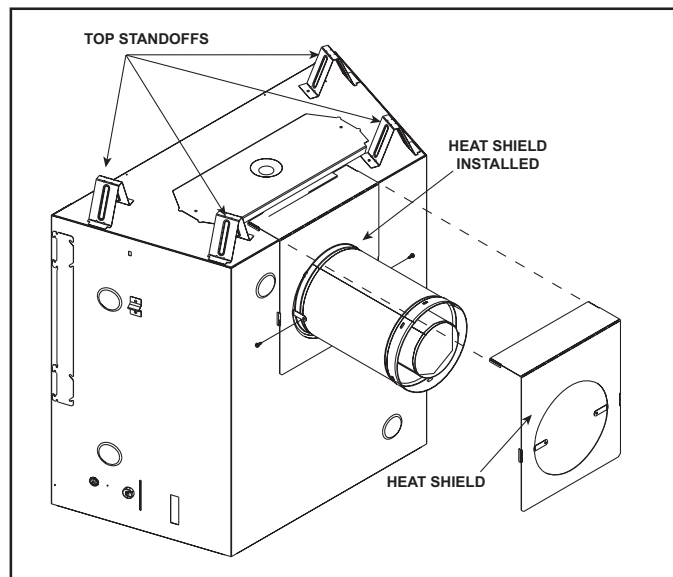

Figure 3. Heat Shield

MODEL: SL-350TRS-CE-D

RECESSED DEPTH: 41.3cm

Minimum Clearances from the Fireplace to Combustible Materials					
<i>Glass Front</i>	<i>Floor</i>	<i>Back of Fireplace</i>	<i>Sides of Fireplace</i>	<i>Top of Fireplace</i>	<i>Ceiling</i>
91.4cm	0	1.3cm	1.3cm	3.8cm	79cm

Minimum Clearances from the Flue Pipe to Combustible Materials						
For Horizontal Sections			For Vertical Sections	At Wall Firestops		
Top	Bottom	Sides	2.54 cm	Top	Bottom	Sides
7.6 cm	2.54 cm	2.54 cm		6.4 cm	1.3 cm	2.54 cm

Step 2 Framing the Fireplace

Fireplace framing can be built before or after the fireplace is set in place. Framing should be positioned to accommodate wall coverings and fireplace facing material. The diagram below shows framing reference dimensions.

CAUTION

MEASURE FIREPLACE DIMENSIONS, AND VERIFY FRAMING METHODS AND WALL COVERING DETAILS, BEFORE FRAMING CONSTRUCTION BEGINS.

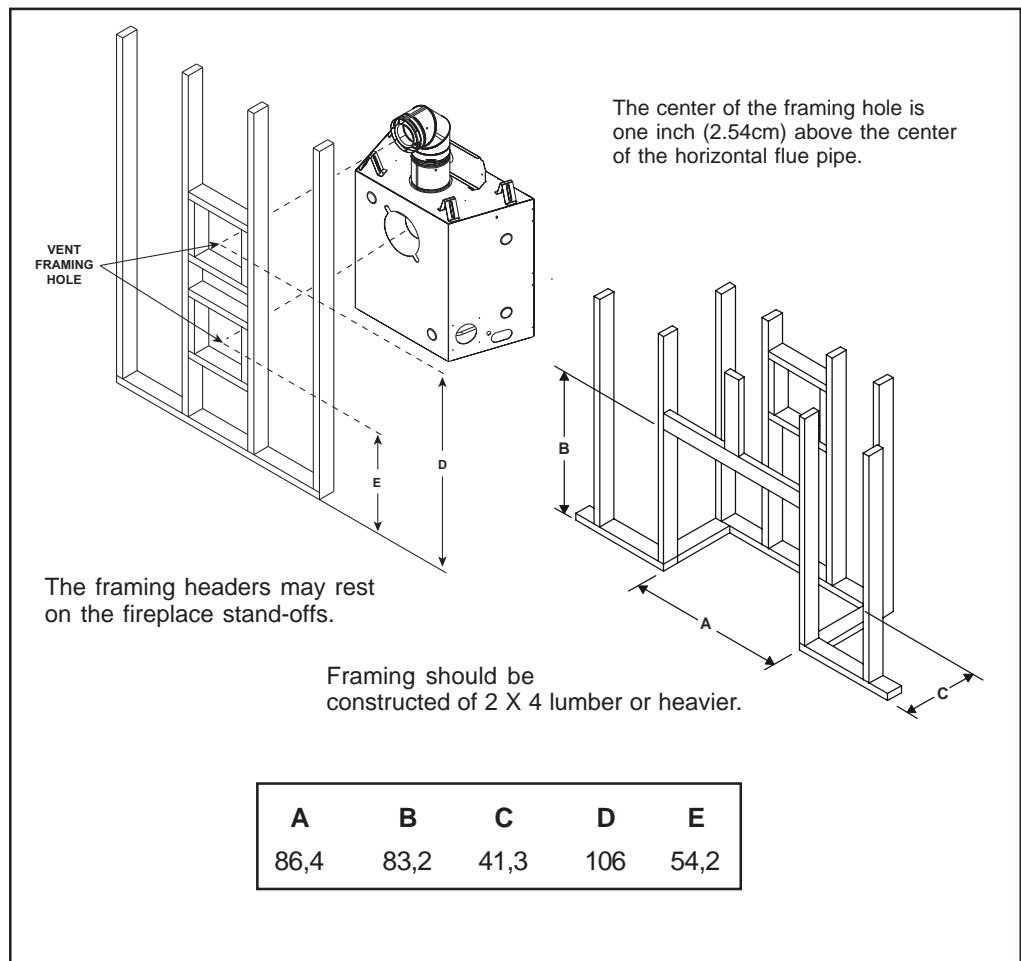

Figure 4. Framing Dimensions

Step 3 Installing the Flue System

A. Flue System Approvals

These models have flue starting collars on both the top and the back of the unit. Depending upon the installation, decide which ONE set of starting collars will be used to attached the flue system. The starting collar sealing cap must remain on the starting collar NOT used.

These models use SL-D-series, direct flue components when using the **TOP** flue collars and DVP-series direct flue components when using the **REAR** flue collars.



WARNING: YOU MUST NOT MIX DVP-SERIES AND SL D-SERIES COMPONENTS IN ANY FLUE SYSTEM CONFIGURATION.

Approved flue system components are labeled for identification. **NO OTHER FLUEING SYSTEMS OR COMPONENTS MAY BE USED.** Detailed installation instructions are included with each flue termination kit and should be used in conjunction with this *Installers Guide*. Figure 4 shows flue system components and terminations.

Identifying Flue Components

The flue systems installed on this gas fireplace may include one, two, or three 90° elbow assemblies. The relationships of vertical rise to horizontal run in flue configurations using 90° elbows **MUST BE** strictly adhered to. The rise to run relationships are shown in the flueing drawings and tables on the next several pages.

NOTE: Two 45° elbows may be used in place of one 90° elbow. You **MUST** always maintain the **MAXIMUM** and **MINIMUM** rise-to-run ratios in the flue system when using 45° elbows.

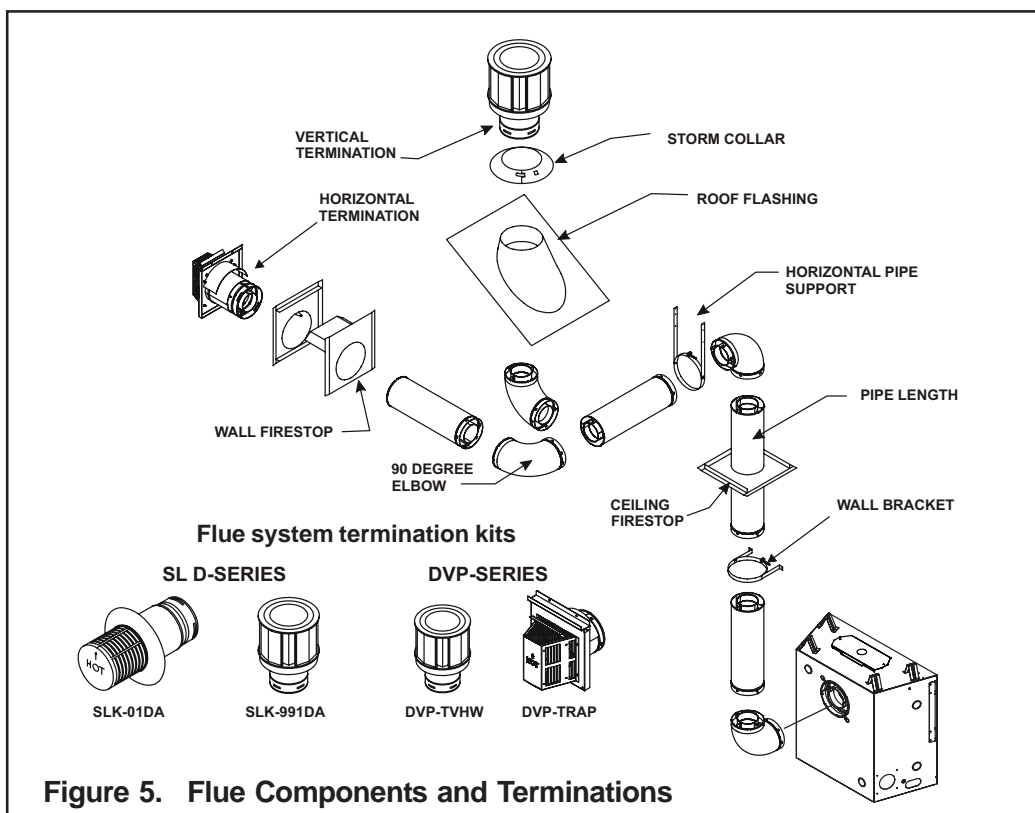

Figure 5. Flue Components and Terminations

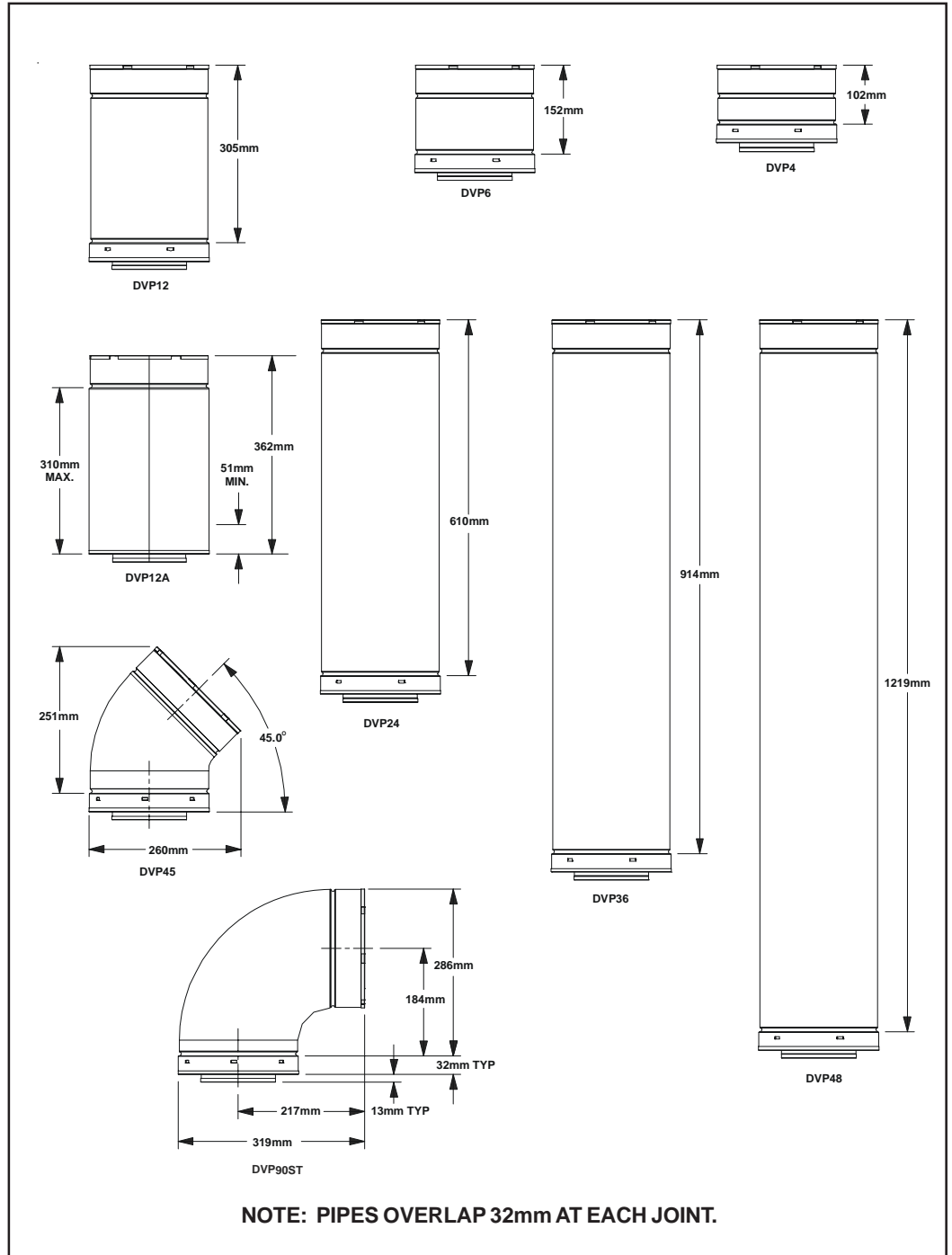
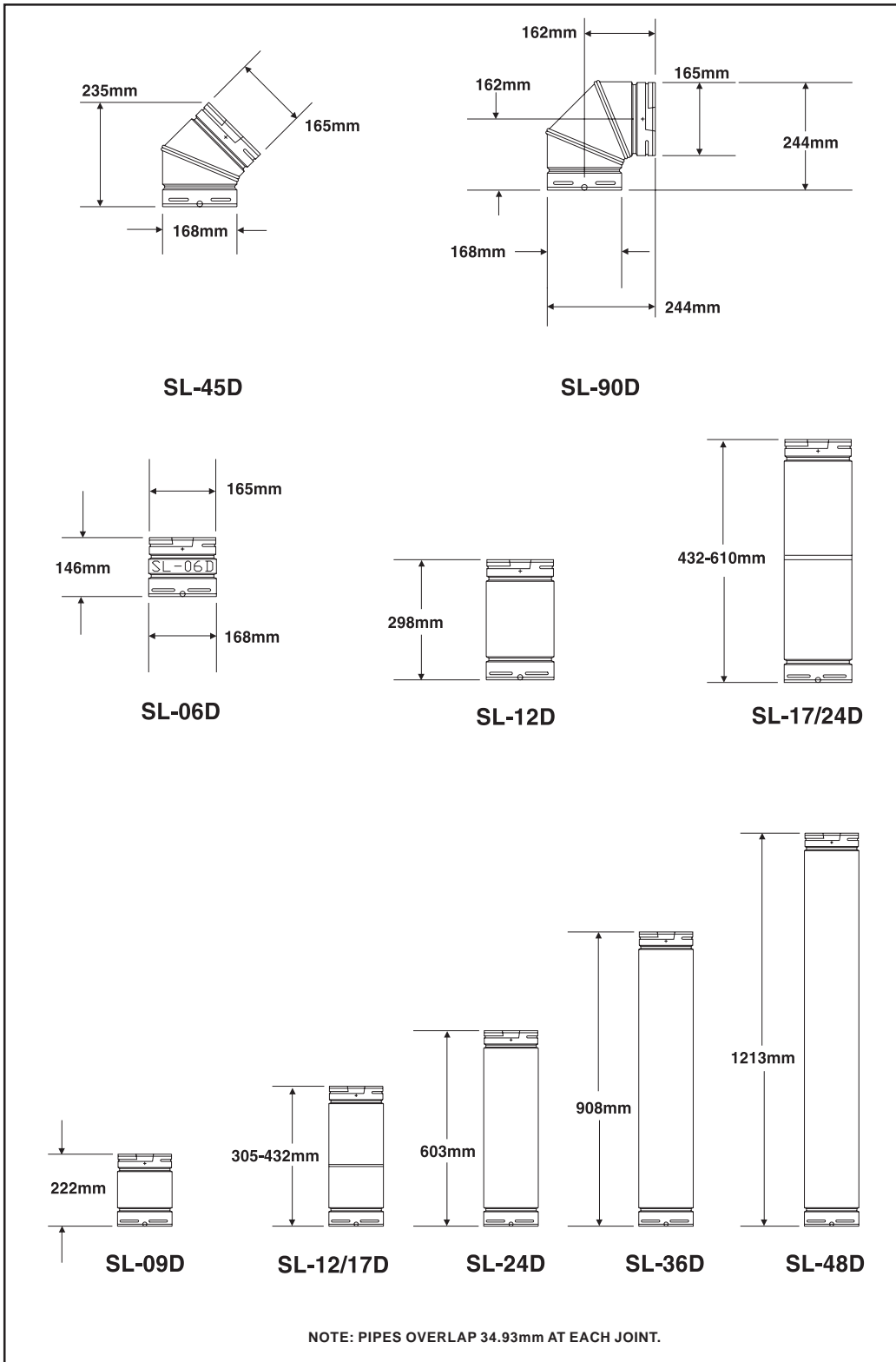
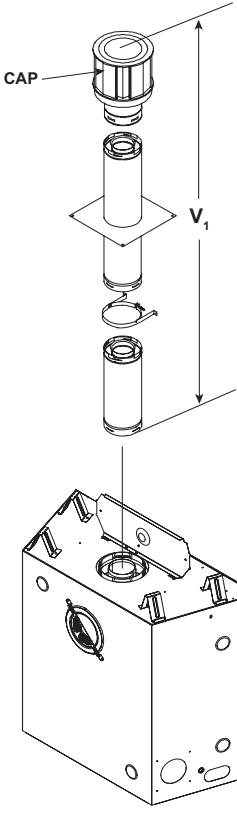

FIGURE 6. DVP-Series Balanced Flue Component Specifications (127mm inner pipe / 203mm outer pipe)



**Figure 7. SL D-Series Flue Component Specifications
(102mm inner pipe/168mm outer pipe)**

**STRAIGHT UP
VERTICAL FLUE**
V
11.8m MAX.



**Use SL D-Series
components only.**

Figure 8. Straight up Vertical Flue

**STRAIGHT OUT HORIZONTAL
FLUE**
H
Max. Run
610mm

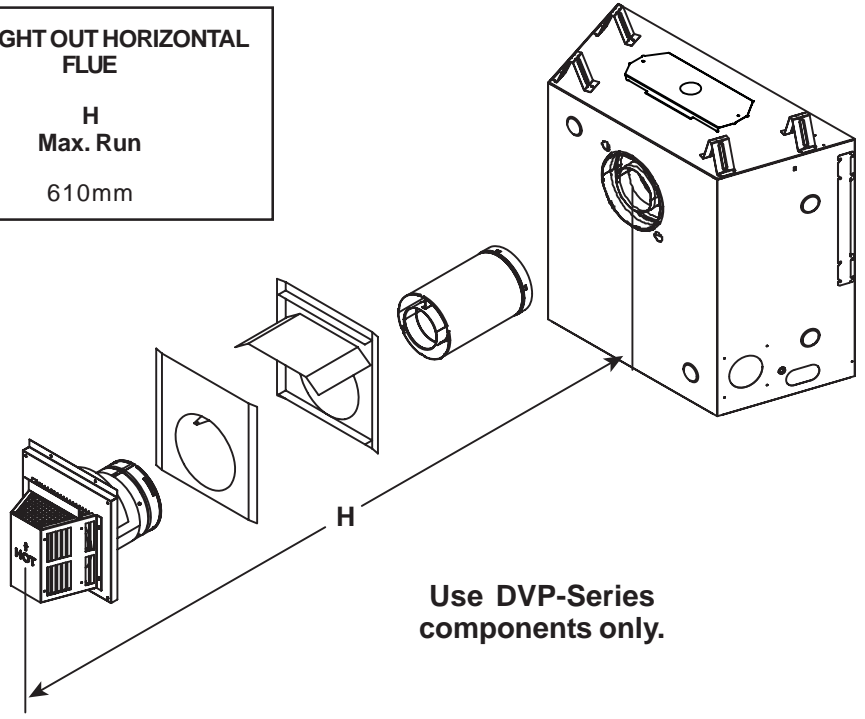

**Use DVP-Series
components only.**

Figure 9. Straight Out Horizontal Flue

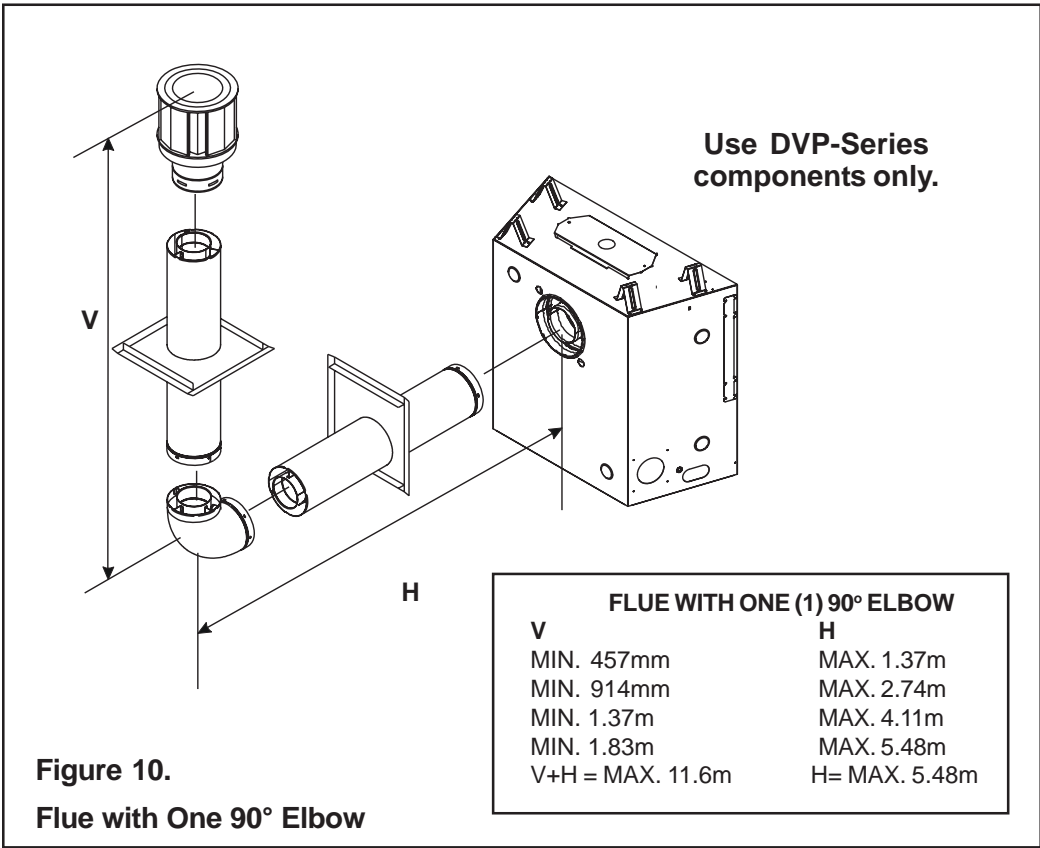

FLUE WITH ONE (1) 90° ELBOW	
V	H
MIN. 381mm	MAX. 1.43m
MIN. 762mm	MAX. 2.29m
MIN. 1.14m	MAX. 3.43m
MIN. 1.52m	MAX. 4.57m
V + H = MAX 11.6m	H = MAX. 4.57m

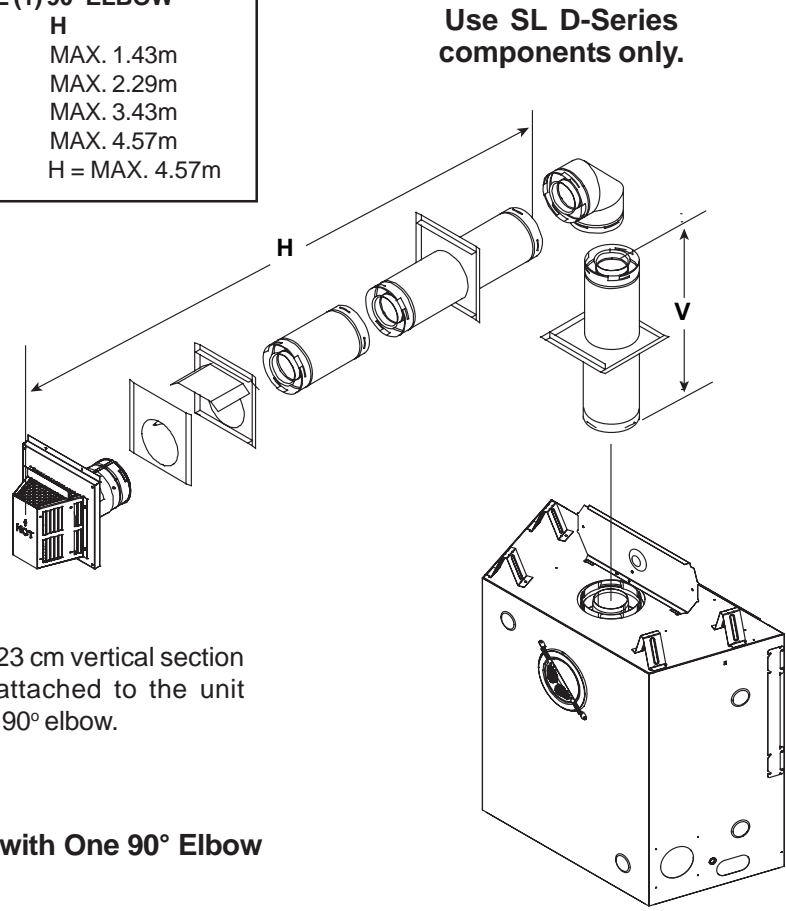

FLUE WITH TWO (2) 90° ELBOWS

V	H	H + H ₁
MIN. 305 mm	MAX. 610 mm	MAX. 1.22 m
MIN. 610 mm	MAX. 1.22 m	MAX. 2.4 m
MIN. 914 mm	MAX. 1.86 m	MAX. 3.6 m
MIN. 1.22 m	MAX. 2.48 m	MAX. 4.8 m
H = MAX. 2.48 m		H + H ₁ = MAX. 4.8m
V + H + H ₁ = 11.6m MAX.		

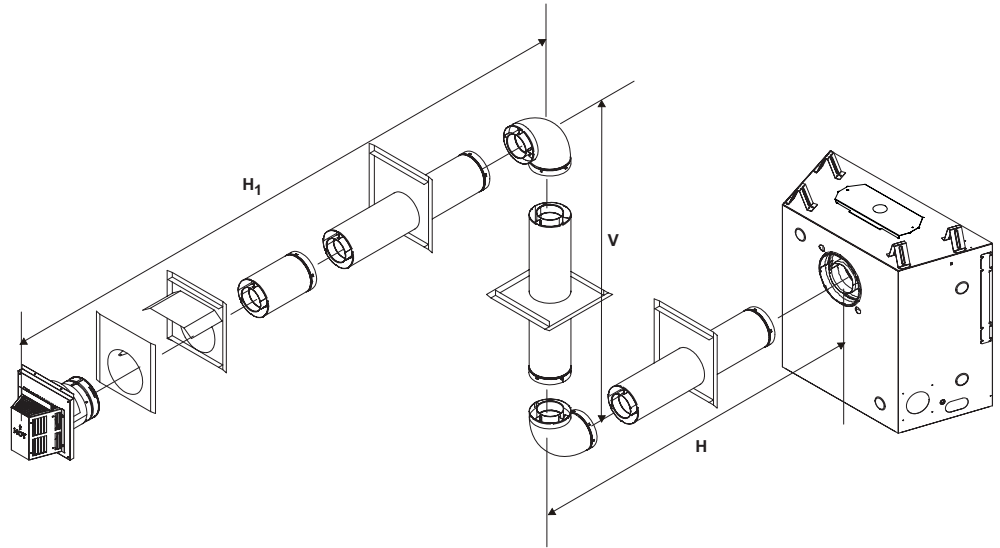

Use DVP-Series components only.

FLUE WITH TWO (2) 90° ELBOWS

V	H + H ₁
MIN. 305 mm	MAX. 610 mm
MIN. 610 mm	MAX. 1.22 m
MIN. 914 mm	MAX. 1.86 m
MIN. 1.22 m	MAX. 2.48 m
H + H ₁ = MAX. 2.48 m	
V + H + H ₁ = 11.6m MAX.	

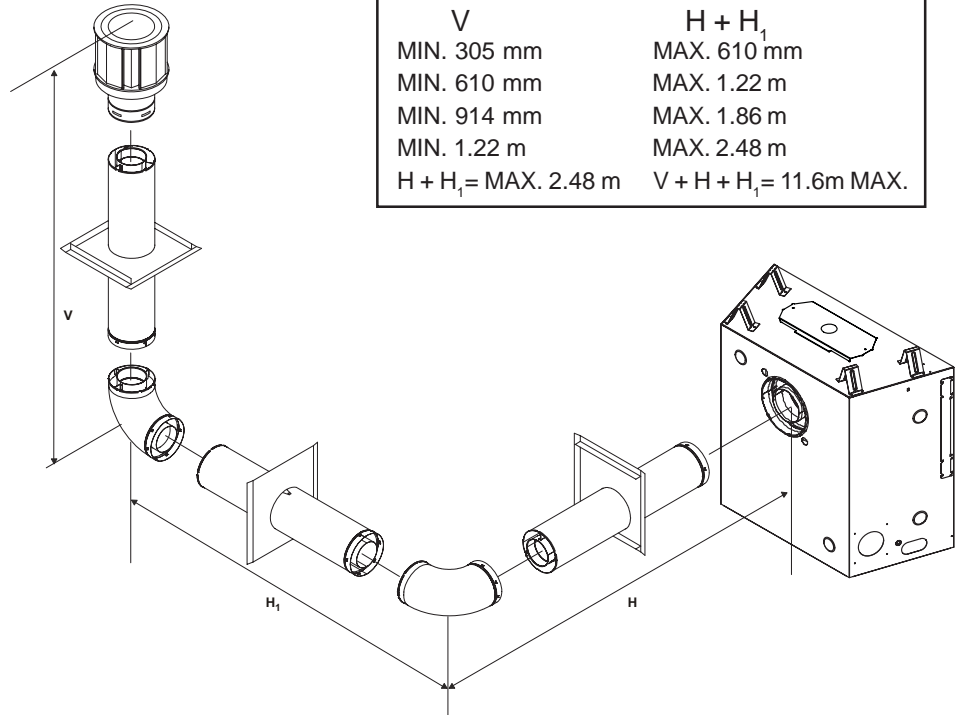

Figure 12. Flue with Two 90° Elbows

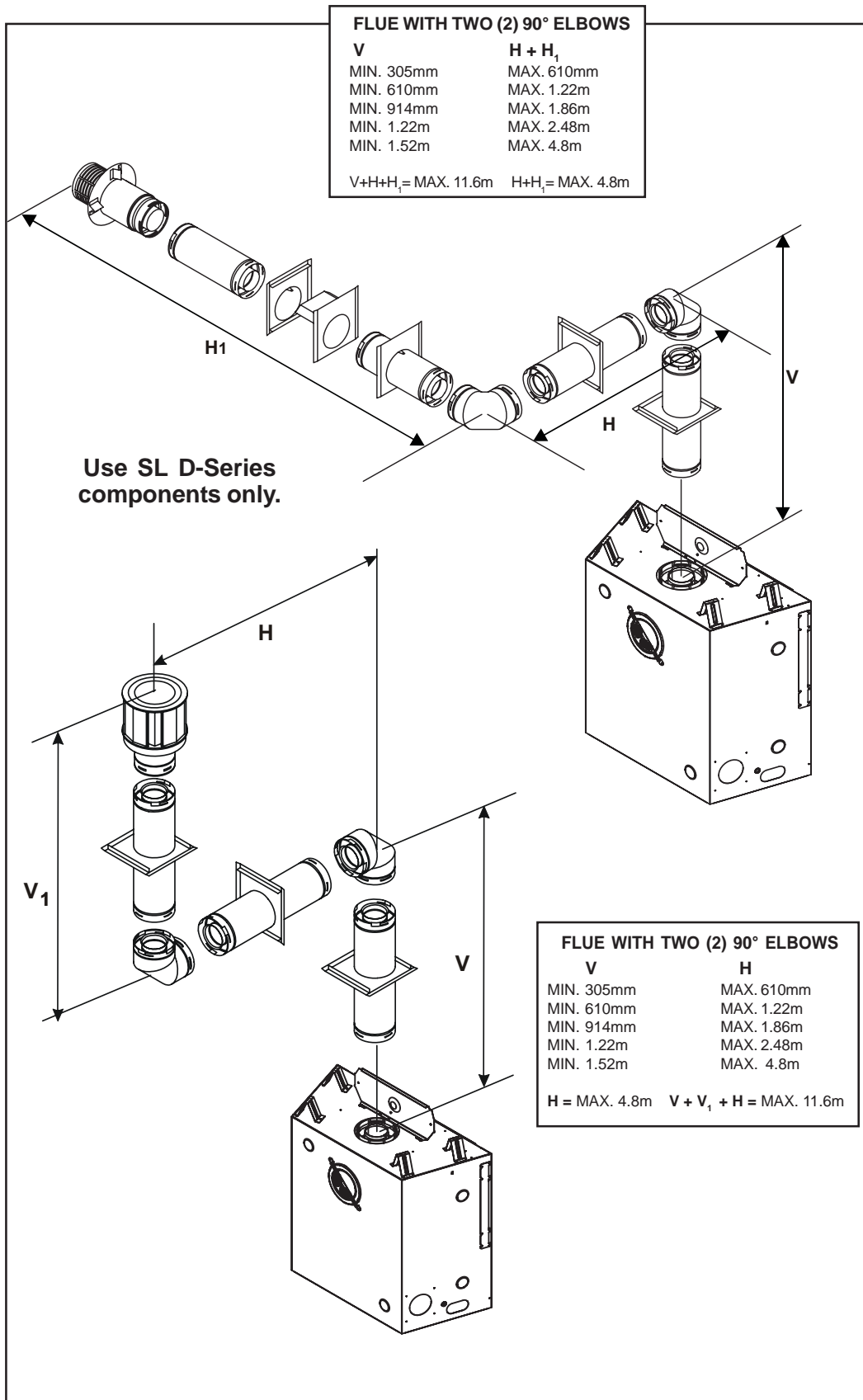

Figure 13. Flue with Two 90° Elbows

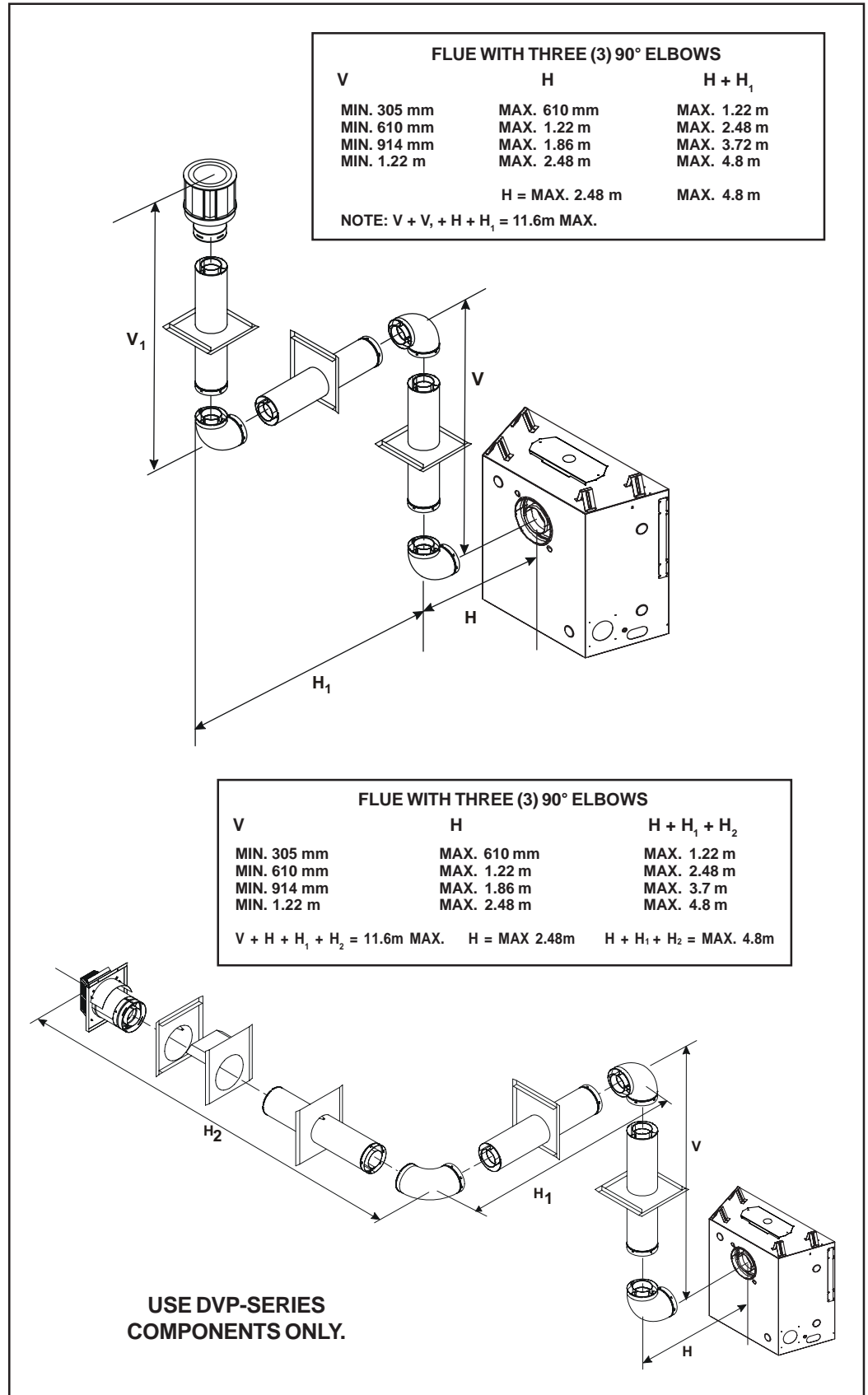
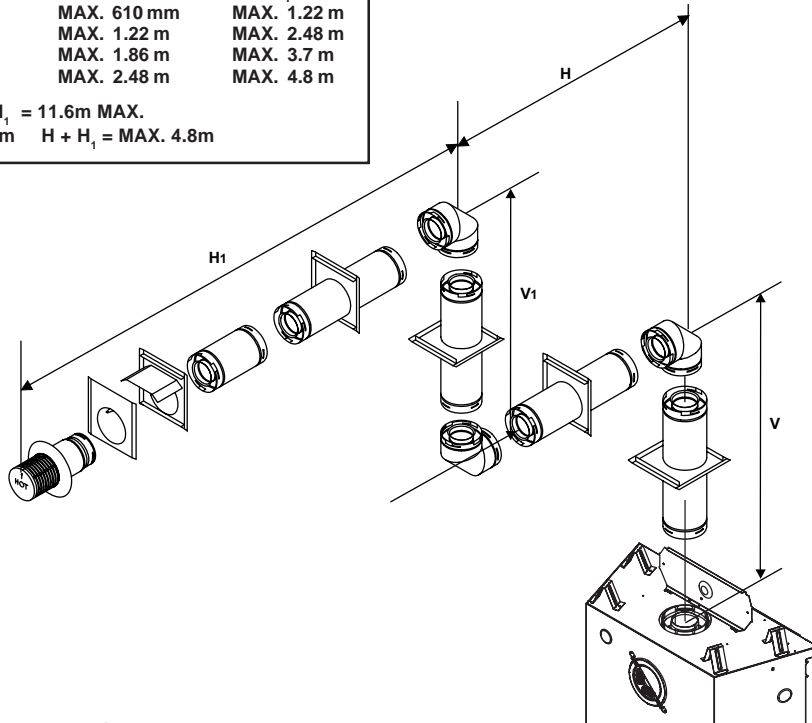

Figure 14. Flue with three 90° elbows

FLUE WITH THREE (3) 90° ELBOWS

V	H	H + H ₁
MIN. 305 mm	MAX. 610 mm	MAX. 1.22 m
MIN. 610 mm	MAX. 1.22 m	MAX. 2.48 m
MIN. 914 mm	MAX. 1.86 m	MAX. 3.7 m
MIN. 1.22 m	MAX. 2.48 m	MAX. 4.8 m

V + V₁ + H + H₁ = 11.6m MAX.
 H = MAX 2.48m H + H₁ = MAX. 4.8m



**USE SL D-SERIES
 COMPONENTS ONLY.**

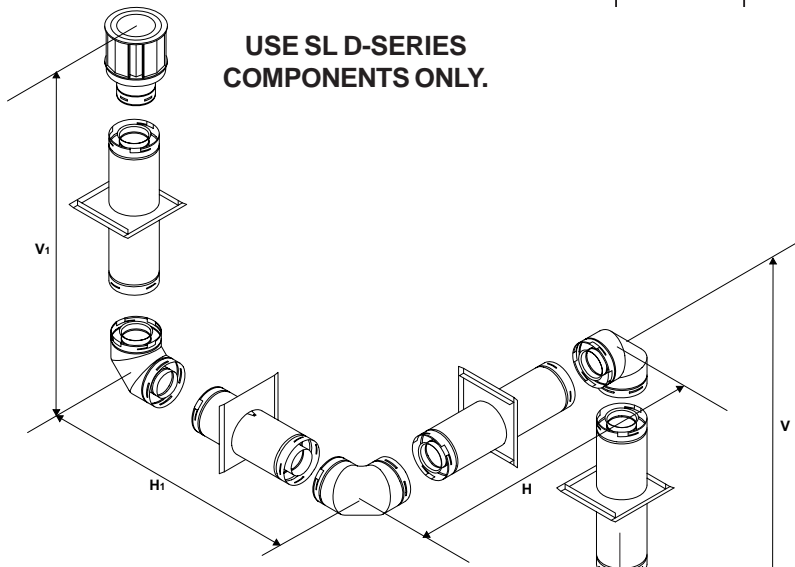

FLUE WITH THREE (3) 90° ELBOWS

V	H	H + H ₁
MIN. 305 mm	MAX. 610 mm	MAX. 1.22 m
MIN. 610 mm	MAX. 1.22 m	MAX. 2.48 m
MIN. 914 mm	MAX. 1.86 m	MAX. 3.7 m
MIN. 1.22 m	MAX. 2.48 m	MAX. 4.8 m

V + V₁ + H + H₁ = 11.6m MAX.
 H = MAX 2.48m H + H₁ = MAX. 4.8m

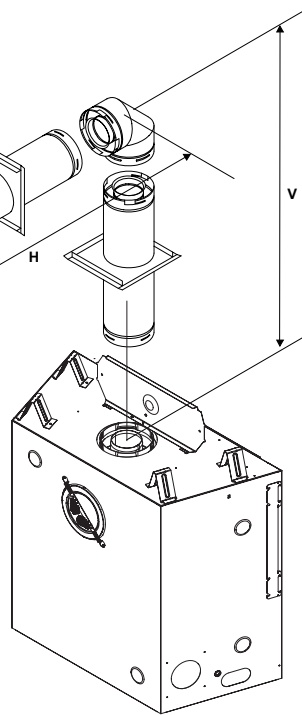

Figure 15. Flue with three 90° elbows

Appliance Preparation

After determining which set of starting collars will be used (top or rear), follow flueing instructions accordingly.



WARNING: FAILURE TO REMOVE INSULATION IN THE SET OF COLLARS YOU ARE USING COULD CAUSE A FIRE.



WARNING: YOU MUST LEAVE THE INSULATION AND FLUE CAP IN PLACE IN THE SET OF COLLARS YOU ARE NOT USING.



WARNING: FIRE RISK ONCE APPLIANCE IS SETUP FOR TOP OR REAR FLUEING, IT CANNOT BE CHANGED AT A LATER TIME. IF FLUE CAP AND COMPONENTS PREVIOUSLY REMOVED ARE IMPROPERLY REINSTALLED, A FIRE MAY RESULT.

CAUTION

Sharp edges-Wear protective gloves and safety glasses during installation.

Top Flue



Figure 16. For top flue, remove the two screws holding the top heat shield in place. For rear flue, see next page.



WARNING: FIRE RISK DO NOT REMOVE HEAT SHIELD. ELEVATED HEADER TEMPERATURES MAY CAUSE A FIRE.



Figure 17. Rotate the top heat shield to the vertical position as shown above. The heat shield must remain in the vertical position.

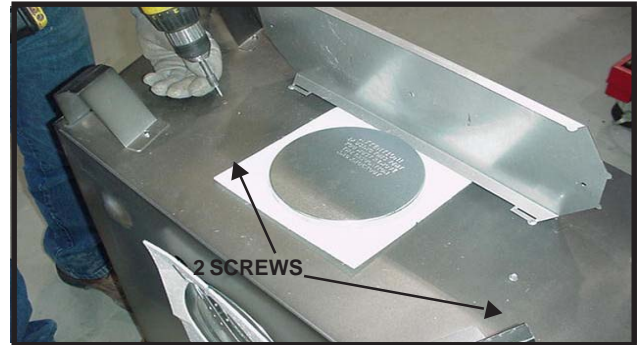

Figure 18. Replace the two screws as shown.

Note: Actual unit may look different than the fireplace shown in this section.



Figure 19. Remove the flue cap.



Figure 20. Remove the insulation basket and white insulation from the center flue pipe.



Figure 21. Remove the insulation from the outer flue pipe.

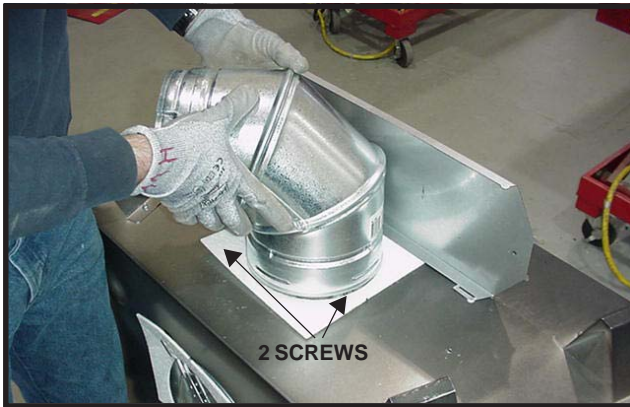

Figure 22. To attach the first section of vent pipe, make sure to use the fiberglass gasket to seal between the first vent component and the outer fireplace wrap. Use 2 self tapping screws to secure the gasket to the outer wrap.

Note: Once the flue cap has been removed, it cannot be reattached.

Rear Flue

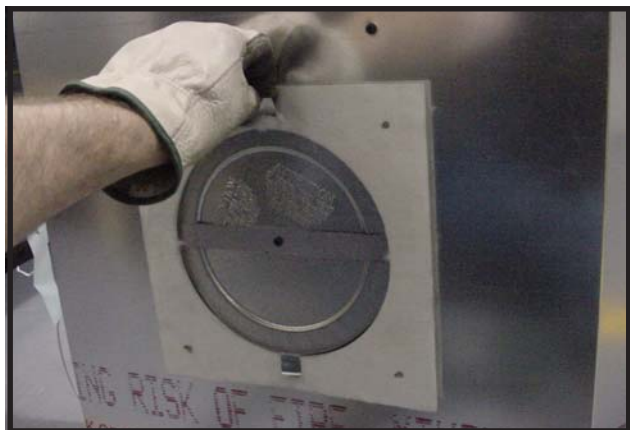

Figure 23. Remove the insulation from the outer flue pipe.



Figure 24. Cut the metal retaining band and fold the sides out.



Figure 25. Fold the center parts of the retaining band out and use to remove the flue cap.



Figure 26. Discard the flue cap, remove and discard the insulation basket. Note: Once the flue cap has been removed it CANNOT be reattached.



Figure 27. Attach the first flue section (it will snap into place). Slide the insulation gasket onto the flue section, up against the appliance and over the tabs. Use two self-tapping screws to secure gasket to outer wrap.

B. Installing Flue Components

1. Attaching the First Flue Component to the Starting Collars:

A. On the REAR of the heater

- To attach the first flue component to the starting collars on the rear of the heater make sure that the heater gasket supplied with the heater seals between the first flue component and the outer heater wrap.
- Slide the male end of the inner flue of the pipe section over the inner collar on the heater. At the same time, slide the outer flue over the outer collar on the heater. Push the flue section into the appliance collar until all the lances (see Figure 28) have snapped in place. Tug slightly on the flue to confirm that it has completely locked into place.
- The first 90° elbow installed in the flue system of a rear flueing heater **MUST BE** in a vertical position.

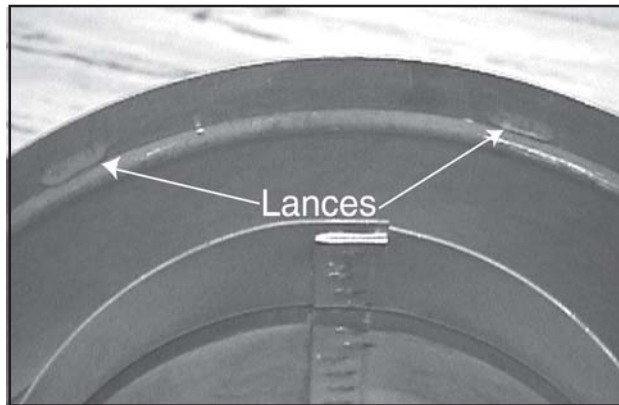

FIGURE 28.

B. On the TOP of the heater

To attach the first flue component to the starting collars on the top of the heater:

- Lock the flue components into place by sliding the concentric pipe sections with four (4) equally spaced interior beads into the heater collar or previously installed component end with four (4) equally spaced indented sections.
- When the internal beads of each outer pipe line up, rotate the pipe section clockwise about one quarter (1/4) turn. The flue pipe is now locked together.
- Slide the ceramic fiber pad over the first flue section and place it flush to the fireplace. Continue to add vent components.

WARNING: ENSURE THAT THE HEATER GASKET SUPPLIED WITH THE HEATER SEALS BETWEEN THE FIRST FLUE COMPONENT AND THE OUTER HEATER WRAP.

C. Continue Adding Flue Components

To continue adding flue components in accordance with the pre-planned flue system configuration:

- Ensure that each succeeding flue component is securely fitted and locked into the preceding component in the flue system. **NOTE:** Make sure that seams are **NOT** aligned to prevent unintentional disconnection.
- For elbows that are changing the flue direction, two screws minimum should be put in the outer flue at the joint to prevent the elbow from rotating.

3. Install Support Brackets

For Horizontal Runs - The flue system must be supported every five (5) feet (1.5m) of horizontal run by a horizontal pipe support.

To install support brackets for horizontal runs:

- Place the pipe supports around the flue pipe.
- Nail the pipe supports to the framing members.

For Vertical Runs - The flue system must be supported every 2.4 m above the heater flue outlet by wall brackets.

To install support brackets for vertical runs:

- Attach wall brackets to the flue pipe and secure the wall bracket to the framing members with nails or screws.

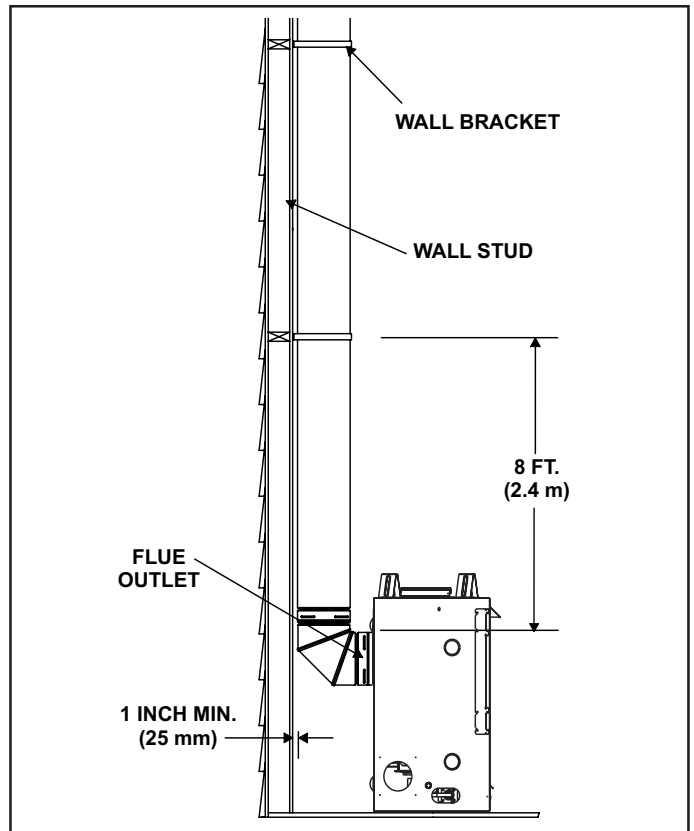

Figure 29. Installing Support Brackets

4. Install Firestops

For Horizontal Runs - Firestops are **REQUIRED** on both sides of a combustible wall through which the flue passes.

To install firestops (heat shield) for horizontal runs that pass through either interior or exterior walls:

- Cut a 10-inch by 12-inch (254 mm X 305 mm) hole through the wall.
- Position the firestops on both sides of the hole previously cut and secure the firestops with nails or screws.
- The pipe opening of the firestops **MUST BE** placed towards the bottom of the firestop.
- Continue the flue run through the firestop.

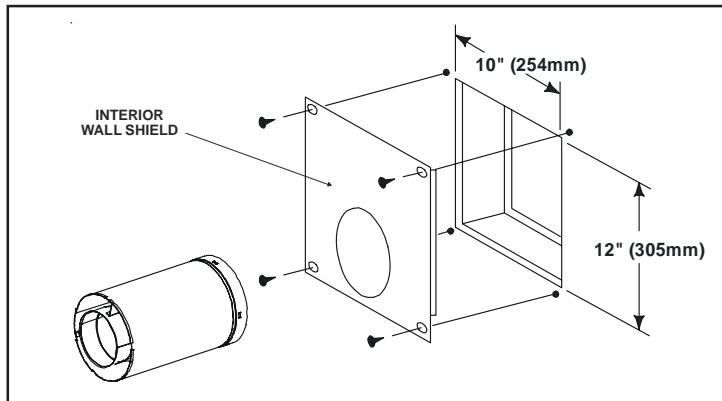

FIGURE 30. Flue Pipe & Firestop

For Vertical Runs - One firestop is **REQUIRED** at the hole in each ceiling through which the flue passes.

To install firestops for vertical runs that pass through ceilings:

- Position a plumb bob directly over the center of the vertical flue component.
- Mark the ceiling to establish the centerpoint of the flue.
- Drill a hole or drive a nail through this center point.
- Check the floor above for any obstructions, such as wiring or plumbing runs.
- Reposition the heater and flue system, if necessary, to accommodate the ceiling joists and/or obstructions.
- Cut a 10-inch X 10-inch (254mm X 305mm) hole through the ceiling, using the firestop pipe opening as a guide.
- Frame the hole with framing lumber the same size as the ceiling joists.

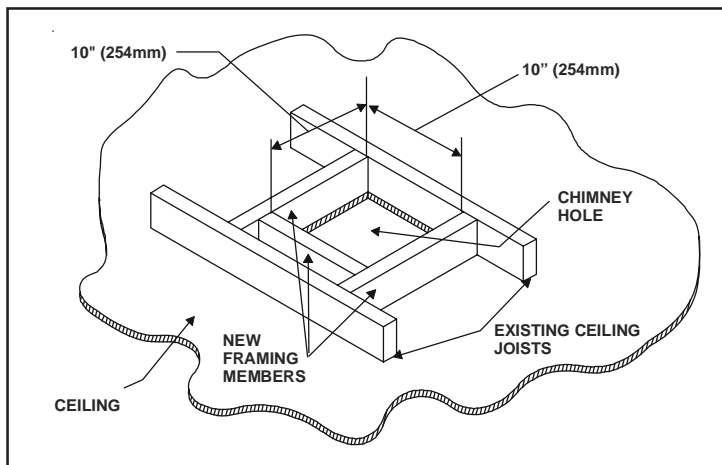

FIGURE 31. Hole and New Framing Members

If the area above the ceiling is **NOT** an attic, position and secure the ceiling firestop on the ceiling side of the previously cut and framed hole.

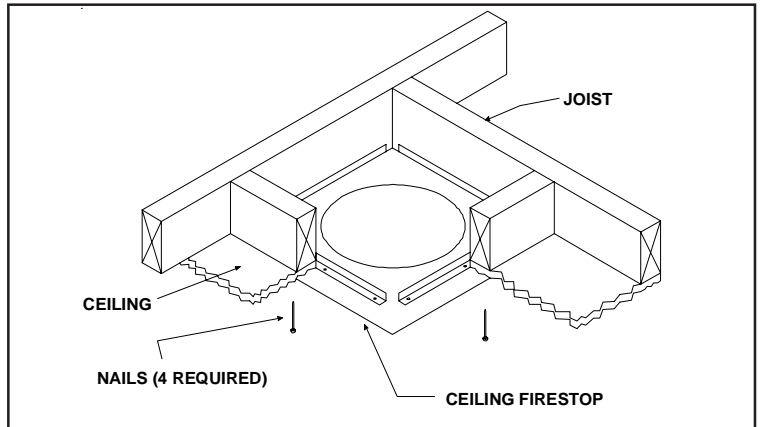

FIGURE 32. Ceiling Firestop (Ceiling Side)

If the area above the ceiling **IS** an attic, position and secure the firestop on top of the previously framed hole.

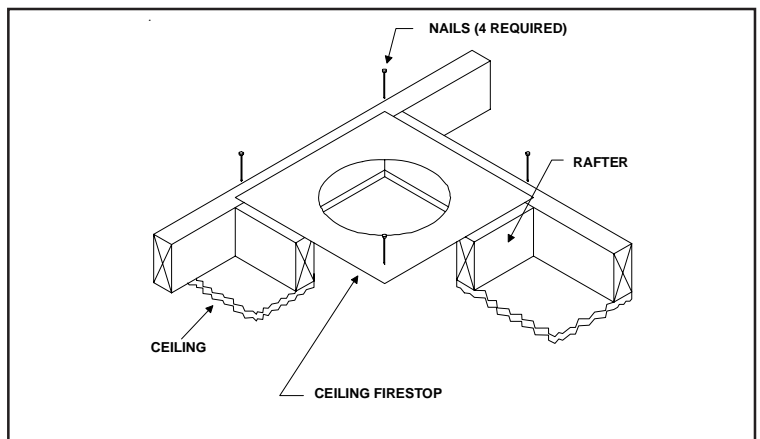

FIGURE 33. Attic Firestop

C. Flue Termination

CAUTION:

IF EXTERIOR WALLS ARE FINISHED WITH VINYL SIDING, IT IS NECESSARY TO INSTALL THE VINYL PROTECTOR KIT (VPK-DV) TO THE TOP OF THE EXTERIOR FIRESTOP FOR ALL ROUND TERMINATION CAPS).

For Horizontal Terminations using the DVP-TRAP

To attach and secure the termination to the last section of horizontal flue:

- The rear flue heat shield **MUST** be placed one inch above the top of the flue between the wall shield and the base of the termination cap.
- One section of the heat shield is attached to the wall shield. The other is attached to the termination cap in the same manner (see Figure 34).

- The heat shield sections will overlap to match the wall thickness (depth). The small leg in the shield rests on top of the flue to properly space it from the pipe section (see Figure 34).

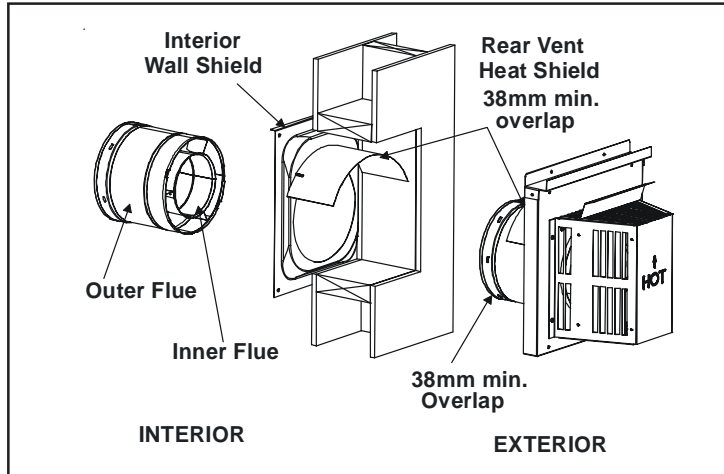

FIGURE 34. Venting through the Wall

- The termination kit should pass through the wall firestops from the exterior of the building.
- Adjust the termination cap to its final exterior position on the building and interlock the flue sections.



WARNING: THE TERMINATION CAP MUST BE POSITIONED SO THAT THE ARROW IS POINTING UP.

- Use a high-temperature sealant gasket to seal between the pipe and exterior firestop.

For Horizontal Terminations using the SLK-01DA

To attach and secure the termination to the last section of horizontal flue:

- Rotate and interlock the ends as described at the beginning of the Installing Flue Components section.
- The termination kit should pass through the wall firestops from the exterior of the building.
- Adjust the termination cap to its final exterior position on the building.



WARNING: THE TERMINATION CAP MUST BE POSITIONED SO THAT THE ARROW IS POINTING UP.

- Use the exterior pipelock hole provided on the round flange of the wall firestop to secure the flue pipe in place.
- Use a high-temperature sealant or fiberglass rope gasket to seal between the pipe and exterior firestop.
- See Figure 37 for flue termination clearances.

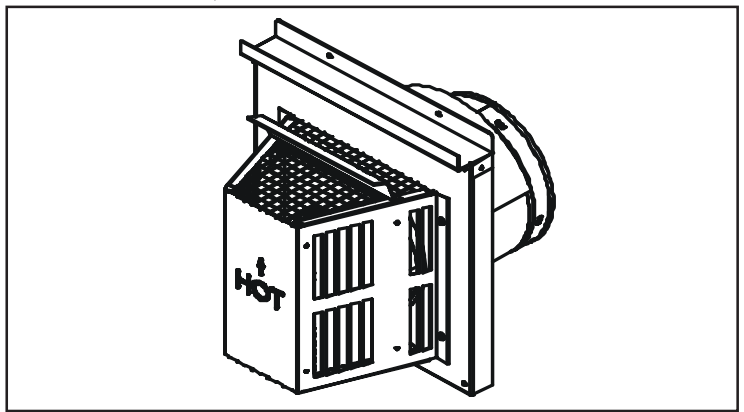

Figure 35. Termination cap

For Vertical Terminations - To locate the flue and install the flue sections:

- Locate and mark the flue centerpoint on the underside of the roof, and drive a nail through the centerpoint.
- Make the outline of the roof hole around the centerpoint nail.
- The size of the roof hole framing dimensions depend on the pitch of the roof. There **MUST BE** a 1-inch (25mm) clearance from the vertical flue pipe to combustible materials.
- Mark the roof hole accordingly.
- Cover the opening of the installed flue pipes.
- Cut and frame the roof hole.
- Use framing lumber the same size as the roof rafters and install the frame securely. Flashing anchored to the frame must withstand heavy winds.
- Continue to install concentric flue sections up through the roof hole and up past the roof line until you reach the appropriate distance above the roof.

To seal the roof hole, and to divert rain and snow from the flue system:

- Attach a flashing to the roof using nails, and use a non-hardening mastic around the edges of the flashing base where it meets the roof.
- Attach a storm collar over the flashing joint to form a water-tight seal. Place non-hardening mastic around the joint, between the storm collar and the vertical pipe.
- Slide the termination cap over the end of the flue pipe and rotate the pipe clockwise 1/4 turn (for SL-D Series) or snap into place (for DVP Series).



WARNING:
FOLLOW NATIONAL REGULATIONS
AND CODES OF PRACTICE FOR
MINIMUM CLEARANCES FROM GAS
TERMINALS, AND PLACEMENT OF GAS
TERMINAL.

NOTE

This also pertains to vertical flue systems installed on the outside of the building.

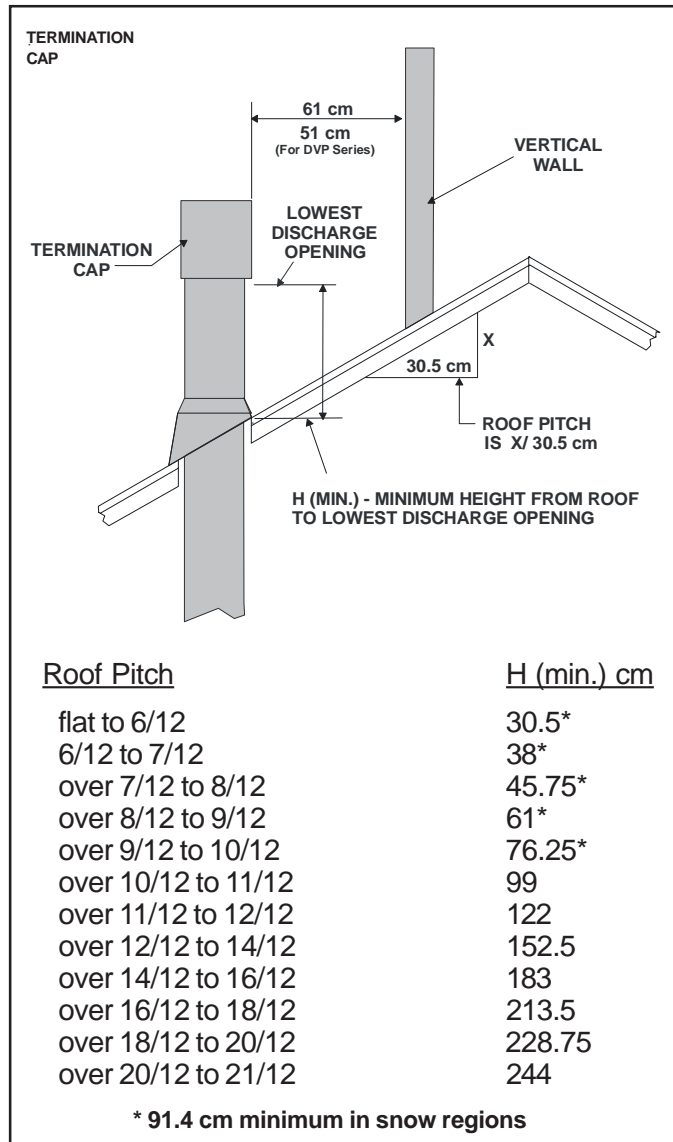
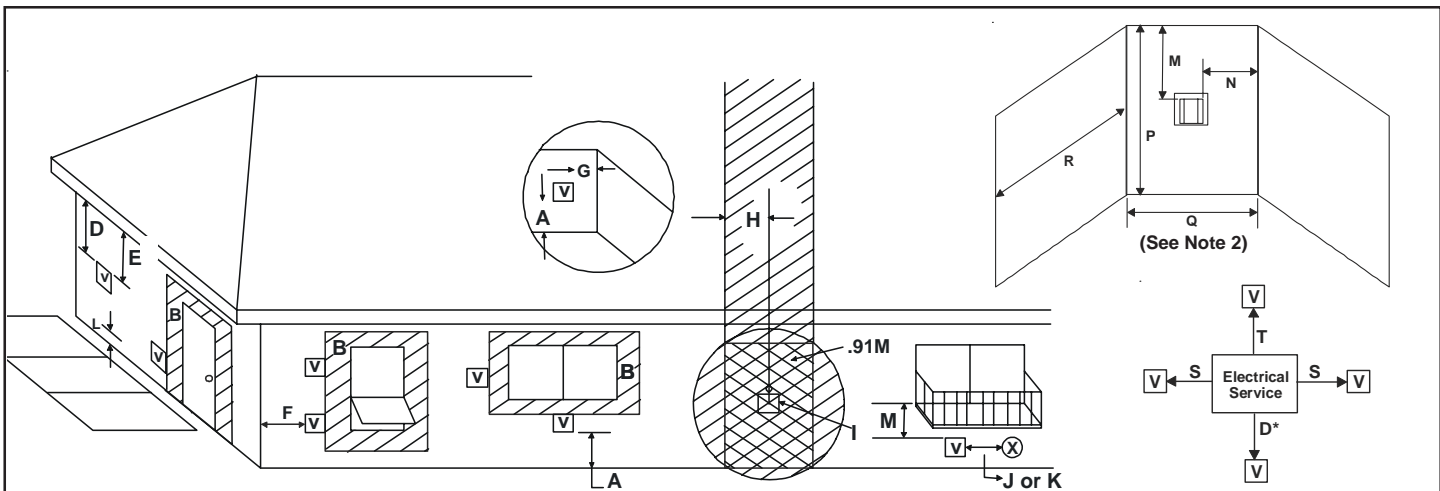

Figure 36. Minimum Height from Roof to Lowest Discharge Opening



V = VENT TERMINAL **X** = AIR SUPPLY INLET = AREA WHERE TERMINAL IS NOT PERMITTED

- A = 30.5 cm clearances above grade, veranda, porch, deck or balcony (See Note 1)
- B = 30.5 cm clearances to window or door that may be opened, or to permanently closed window. (Glass)
- D* = 45.8 cm vertical clearance to unventilated soffit or to ventilated soffit located above the terminal
*76.2 cm for vinyl clad soffits and below electrical service
- F = 22.9 cm clearance to outside corner
- G = 15.3 cm clearance to inside corner
- H = 91.4 cm not to be installed above a gas meter/regulator assembly within 91.4 cm horizontally from the center-line of the regulator
- I = 91.4 cm clearance to gas service regulator vent outlet
- J = 22.9 cm clearance to non-mechanical air supply inlet to building or the combustion air inlet to any other appliance
- K = 91.4 cm clearance to a mechanical (powered) air supply inlet

- L = 2.1 M clearance above paved sidewalk or a paved driveway located on **public** property (See Note 1)
- M** = 45.8 cm clearance under veranda, porch, deck, balcony or overhang
106.7 cm vinyl

Alcove Applications

- N = 15.3 cm non-vinyl sidewalls
30.5 cm vinyl sidewalls
- P = 2.4 M

	Q_{MIN}	R_{MAX}
1 cap	91.4 cm	2 x Q _{ACTUAL}
2 caps	1.8 M	1 x Q _{ACTUAL}
3 caps	2.7 M	2/3 x Q _{ACTUAL}
4 caps	3.7 M	1/2 x Q _{ACTUAL}
Q_{MIN} = # termination caps x 3 R_{MAX} = (2 / # termination caps) x Q_{ACTUAL}		

- S = 15.3 cm clearance from sides of electrical service (See Note 5)
- T = 30.5 cm clearance above electrical service (See Note 5)

** only permitted if veranda, porch, deck or balcony is fully open on a minimum of 2 sides beneath the floor, or meets Note 2.

NOTE 1: On private property where termination is less than 2.1 M above a sidewalk, driveway, deck, porch, veranda or balcony, use of a listed cap shield is suggested. (See vents components page)

NOTE 2: Termination in an alcove space (spaces open only on one side and with an overhang) are permitted with the dimensions specified for vinyl or non-vinyl siding and soffits. **1.** There must be 91.4 cm minimum between termination caps. **2.** All mechanical air intakes within 3.0 M of a termination cap must be a minimum of 91.4 cm below the termination cap. **3.** All gravity air intakes within 91.4 cm of a termination cap must be a minimum of 30.5 cm below the termination cap.

Figure 37 Vent Termination Minimum Clearances

NOTE 3: Local codes or regulations may require different clearances.

NOTE 4: Termination caps may be hot. Consider their proximity to doors or other traffic areas.

NOTE 5: Location of the vent termination must not interfere with access to the electrical service.

NOTE: Vent system termination is permitted in porch areas with two or more sides open. You must follow all side walls, overhang and ground clearances as stated in the instructions.

Heat & Glo assumes no responsibility for the improper performance of the appliance when the venting system does not meet these requirements.

CAUTION: IF EXTERIOR WALLS ARE FINISHED WITH VINYL SIDING, IT IS SUGGESTED THAT A VINYL PROTECTOR KIT BE INSTALLED.

Step 4 Positioning, Leveling, and Securing the Fireplace

1. Place the fireplace into position.
2. Level the fireplace from side to side and from front to back.
3. Shim the fireplace with non-combustible material, such as sheet metal, as necessary.
4. Secure the fireplace to the framing by nailing or screwing.

The diagram below shows how to properly position, level, and secure the fireplace.

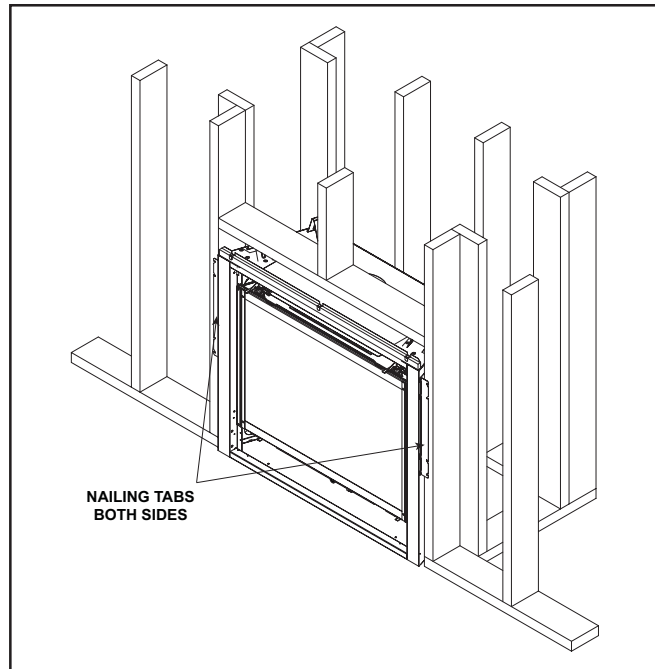

Figure 38. Proper Positioning, Leveling, and Securing of a Fireplace

Step 5 The Gas Control System



WARNING: THIS UNIT IS NOT FOR USE WITH SOLID FUEL.

Standing Pilot Ignition System

This system includes millivolt control valve, standing pilot, thermopile/thermocouple flame sensor, and piezo ignitor.



WARNING: 230 VAC MUST NEVER BE CONNECTED TO A CONTROL VALVE IN A MILLIVOLT SYSTEM.

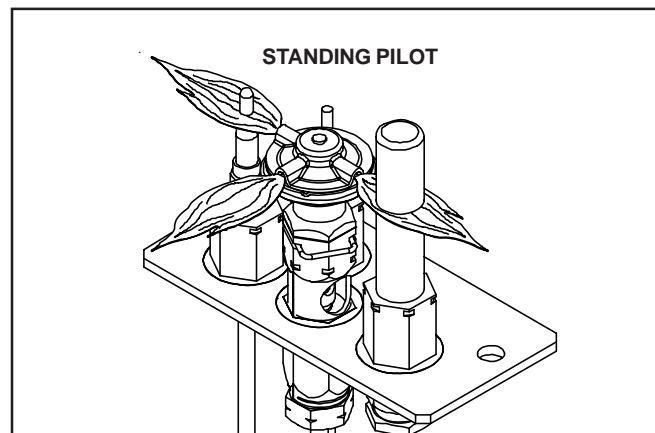

Figure 39. Gas Control System

Step 6 The Gas Supply Line

NOTE: Have the gas supply line installed by a qualified service technician in accordance with all building regulations.

NOTE: Before the first firing of the stove, the gas supply line should be purged of any trapped air.

NOTE: Consult local building regulations to properly size the gas supply line leading to the (Rp 1/2") hook-up at the unit.

This gas inlet connection is ISO 7-Rp 1/2 (BSP Rp 1/2).

To install the gas supply line:

- When attaching the pipe, support the control so that the lines are not bent or torn.
- After the gas line installation is complete, use a soap solution to carefully check all gas connections for leaks.

! WARNING:
DO NOT USE AN OPEN FLAME TO CHECK FOR GAS LEAKS.

- At the gas line access hole, use insulation to repack the space around the gas pipe.
- Insert insulation from the outside of the fireplace and pack the insulation tightly to totally seal between the pipe and the outer casing.

The gas line should be installed by a qualified service technician.

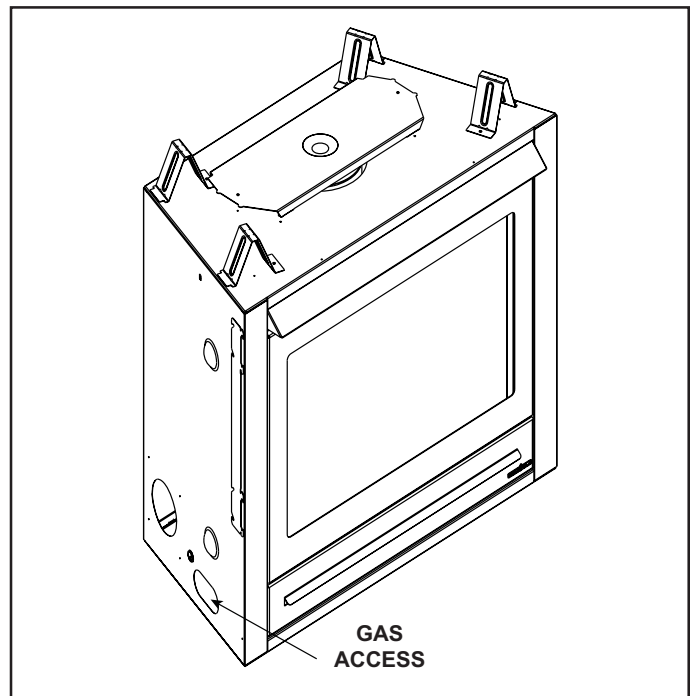

Figure 40

Step 7 Gas Pressure Requirements

Pressure requirements for Heat & Glo gas fireplaces are shown in the table below.

	Natural Gas (G20)	Propane (G31)	Butane (G30)	Natural Gas (G25)
Inlet Pressure	20mbar	37 or 50mbar	30 or 50mbar	25mbar
Manifold Pressure	4-8.7mbar	15.7-25mbar	15.7-25mbar	4-8.7mbar
Gas Rate	.54 m ³ /h	.24 m ³ /h	.16 m ³ /h	.54 m ³ /h
Max.Input(NETCV)	6.0 kW	5.4 kW	5.2kW	5.0 kW
Burner Injector	DMS 44	DMS 55	DMS 56	DMS 42
Pilot Injector	51	30	30	51

A tap is provided on the outlet side of the gas control for a test gauge connection to measure the manifold pressure. To measure inlet pressure, provisions must be made to attach a test gauge to the tap immediately upstream of the gas supply connection to the stove.

The stove and its individual shut-off valve must be disconnected from the gas supply piping system during any pressure testing of the system at test pressures in excess of 60 mbar.

If the stove must be isolated from the gas supply piping system by closing an individual shut-off valve, it must be of the handle-less type.

Step 8 Wiring the Fireplace

NOTE: Electrical wiring must be installed by a competent electrician.

For Standing Pilot Ignition Wiring Appliance Requirements

- This appliance **DOES NOT** require 230 VAC to operate.



WARNING: DO NOT CONNECT 230 VAC TO THE GAS CONTROL VALVE OR THE APPLIANCE WILL MALFUNCTION AND THE VALVE WILL BE DESTROYED.

Optional Accessories

Optional remote control kits require that 230 VAC be wired to the factory installed junction box before the fireplace is permanently installed.

Wall Switch

Position the wall switch in the desired position on a wall. Run a maximum of 7.8 m or less length of 1.02 mm diameter minimum wire and connect it to the stove ON/OFF switch pigtails.



WARNING: DO NOT CONNECT 230 VAC TO THE WALL SWITCH OR THE CONTROL VALVE WILL BE DESTROYED.

CAUTION

LABEL ALL WIRES PRIOR TO DISCONNECTION WHEN SERVICING CONTROLS. WIRING ERRORS CAN CAUSE IMPROPER AND DANGEROUS OPERATION. VERIFY PROPER OPERATION AFTER SERVICING.

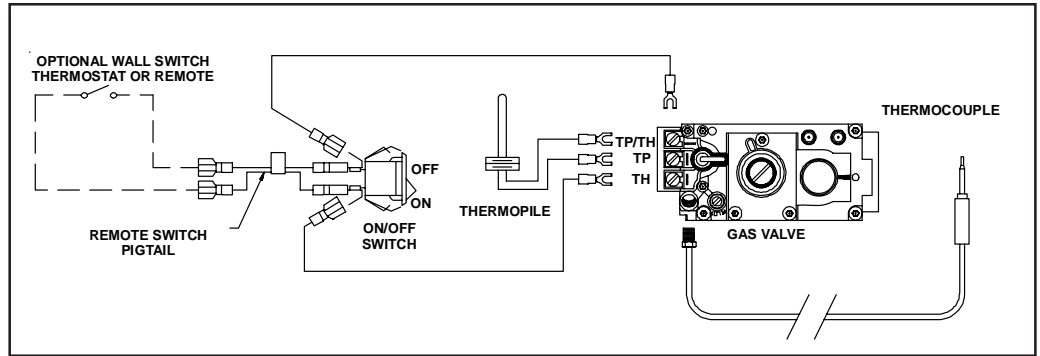

Figure 41. Standing Pilot Ignition Wiring Diagram

**Step 9
Finishing**

The following diagram shows the minimum vertical and corresponding maximum horizontal dimensions of fireplace mantels or other combustible projections above the top front edge of the fireplace. See Figures 2 , 3 and 4 for other fireplace clearances.

Only non-combustible materials may be used to cover the black fireplace front.

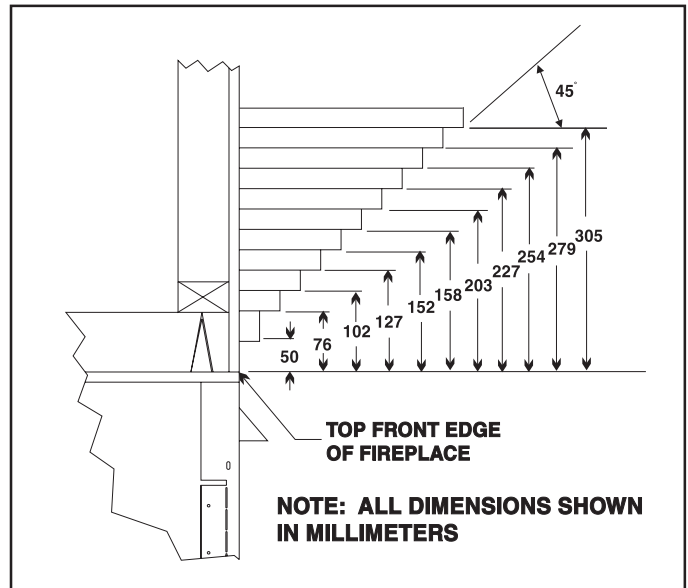

Figure 42. Minimum Vertical and Maximum Horizontal Dimensions of Combustibles above Fireplace



WARNING: WHEN FINISHING THE FIREPLACE, NEVER OBSTRUCT OR MODIFY THE AIR INLET/OUTLET GRILLES IN ANY MANNER.

CAUTION

IF JOINTS BETWEEN THE FINISHED WALLS AND THE FIREPLACE SURROUND (TOP AND SIDES) ARE SEALED, A 150° C. MINIMUM SEALANT MATERIAL MUST BE USED. THESE JOINTS ARE NOT REQUIRED TO BE SEALED. ONLY NONCOMBUSTIBLE MATERIAL (USING 150° C. MINIMUM ADHESIVE, IF NEEDED) CAN BE APPLIED AS FACING TO THE FIREPLACE SURROUND. SEE THE DIAGRAM SHOWN BELOW.

1. Apply only non-combustible facing material to the fireplace surround.

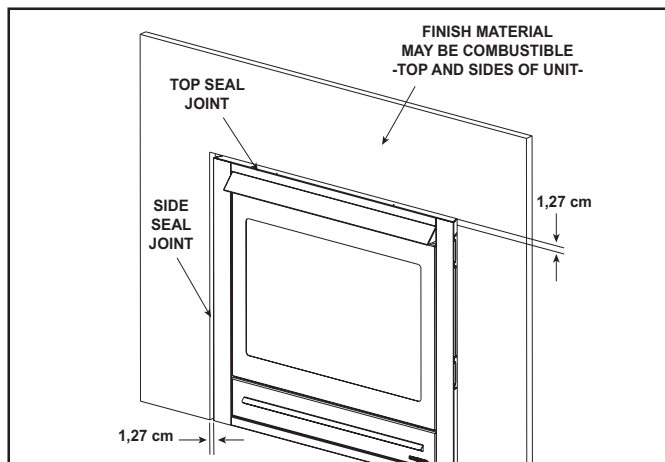

Figure 43. Sealant Material

Step 10 Installing Trim, Logs, and Ember Material

Installing the Trim

Combustible materials may be brought up to the specified clearances on the side and top front edges of the fireplace, but **MUST NEVER** overlap onto the front face. The joints between the finished wall and the fireplace top and sides can only be sealed with a 150° C minimum sealant.

Install optional marble and brass trim surround kits as desired. Marble, brass, brick, tile, or other noncombustible materials can be used to cover up the gap between the sheet rock and the fireplace.

Do not obstruct or modify the air inlet/outlet grilles. When overlapping on both sides, leave enough space so that the bottom grille can be opened and the trim door removed.



WARNING: CHILDREN AND ADULTS SHOULD BE ALERTED TO THE HAZARDS OF HIGH TEMPERATURES OF WORKING SURFACES ON THESE HEATERS. WORKING SURFACES INCLUDE ALL GLASS PANELS AND DECORATIVE DOORS. YOUNG CHILDREN SHOULD BE CAREFULLY SUPERVISED WHEN THEY ARE IN THE SAME ROOM AS THE APPLIANCE.

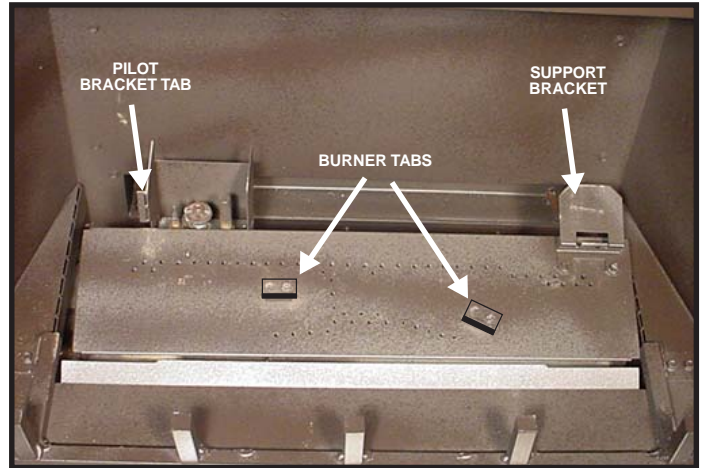

Carefully remove the logs from the packaging. **CAUTION:** Logs are fragile!



LOG #1 (SRV327-701): Place log #1 at the rear of the unit, with the left edge behind the tab on the pilot bracket. The right side sits behind the tab on the support bracket.



LOG #2 (SRV2033-701): Locate the bottom groove of log #2 over the left most grate bar and align over the burner by placing the log slot over the burner tab as shown.



LOG #3 (SRV705-703): Rest log #3 against the right front grate corner and place its slot over the right burner tab.



LOG #4 (SRV530-716): Place the left end of log #4 in the groove on log #2 and the right end on log #1 as shown.



LOG #5 (SRV438-724): Locate the top of log #5 onto log #1 and place the bottom on the right side of the fourth log grate.



LOG #6 (SRV540-704): Place log #6 against the second and third grate bars.

If sooting occurs, the logs might need to be repositioned slightly to avoid excessive flame impingement.

Placing the Ember Material

Ember material is shipped with this gas fireplace. The bag labeled Glowing Ember (050-721) is standard glowing ember material. To place the ember material:

- Remove latches and tension springs around the glass door.
- Remove the glass door from the unit (Figure 44).
- Place small pieces of ember material on burner top around burner ports (Figure 33). Do NOT press embers into burner ports. Cover the top of the burner with a single layer of ember material. Do NOT place embers behind the rear port row as noted in Figure 45.
- Save the remaining ember materials for use during fireplace servicing.
- Replace the glass door and a front trim door on the unit (see Replacement Parts Section of the manual.)
- Replace the latches and tension springs.

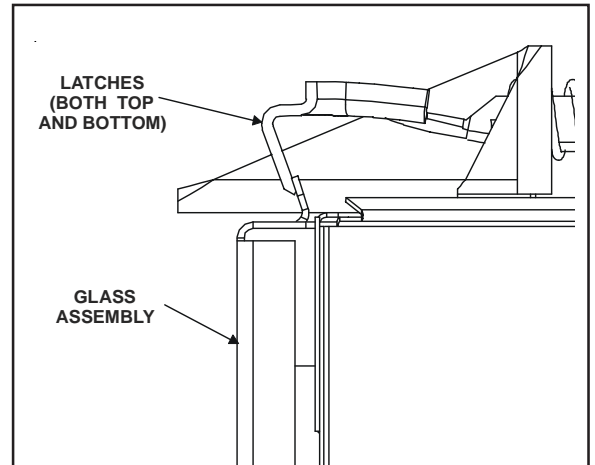

Figure 44. Glass Assembly

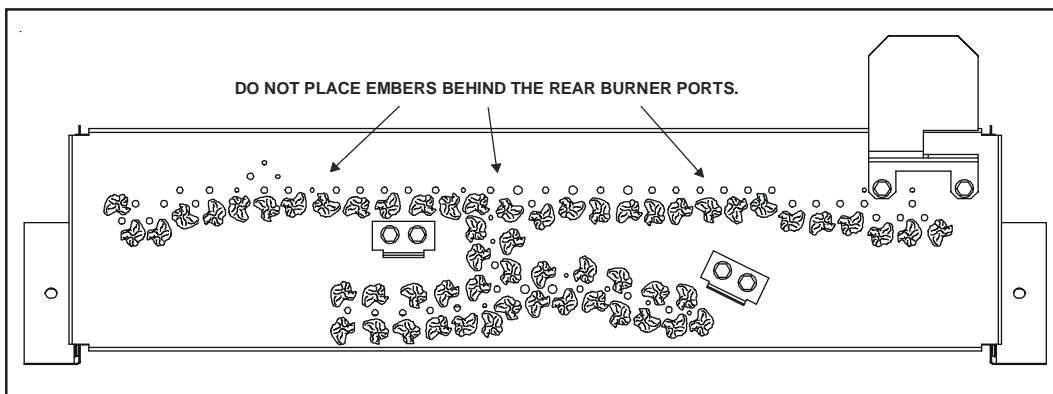

Figure 45. Placement of the Ember Material

Step 11 Before Lighting the Fireplace

Before lighting the fireplace, be sure to do the following:

Review safety warnings and cautions

- Read the **Safety and Warning Information** section at the beginning of this *Installers Guide*.

Double-check for gas leaks

- Before lighting the fireplace, double-check the unit for possible gas leaks.

Double-check flue terminations and front grilles for obstructions.

- Before lighting the fireplace, double-check the unit for possible obstructions that could be blocking the flue terminations or the front grilles.

Double-check for faulty components

- Any component that is found to be faulty **MUST BE** replaced with an approved component. Tampering with the fireplace components is **DANGEROUS** and voids all warranties.

A small amount of air will be in the gas supply lines. When first lighting the fireplace, it will take a few minutes for the lines to purge themselves of this air. Once the purging is complete, the fireplace will light and will operate normally.

Subsequent lightings of the fireplace will not require this purging of air from the gas supply lines, **unless the gas valve has been turned to the OFF position**, in which case the air would have to be purged.

NOTE: The fireplace should be run for 3 to 4 hours on the initial start-up. Turn it off and let it cool completely. Remove and clean the glass. Replace the glass and run the fireplace for an additional 8 hours. This will help to cure the products used in the paint and logs.

During this break-in period it is recommended that some windows in the house be opened for air circulation. This will help avoid setting off smoke detectors, and help eliminate any odors associated with the fireplace's initial burning.

Step 12 Lighting the Fireplace

You've reviewed all safety warnings, you've checked the fireplace for gas leaks, you know the flue system is unobstructed, and you've checked for faulty components. Now you're ready to light the fireplace.



WARNING: PLEASE REFER TO THE USER'S MANUAL FOR ALL CAUTIONS, SAFETY, AND WARNING INFORMATION PERTAINING TO THE LIGHTING AND OPERATION OF THE FIREPLACE.

After the Installation

LEAVE THIS INSTALLATION MANUAL WITH THE APPLIANCE FOR FUTURE REFERENCE.

4

Maintaining and Servicing Your Fireplace

Fireplace Maintenance

Although the frequency of your appliance servicing and maintenance will depend on use and the type of installation, you should have a qualified service technician perform an appliance checkup at the beginning of each heating season. See the table below for specific guidelines regarding each fireplace maintenance task.

IMPORTANT

TURN OFF THE GAS BEFORE SERVICING YOUR FIREPLACE.

Type of Fireplace Maintenance	Frequency	By	Stove Maintenance Task To Be Completed
Replacing Old Ember Material	Once annually, during the annual checkup	Qualified Service Technician	Brush away loose ember material near the burner. Replace old ember material with new 10mm thin pieces Glowing Ember (050-721). New ember material should be placed on top of the burner. Save the remaining ember material and repeat this procedure at your next servicing. For more information, see Placing Ember Material in the INSTALLERS GUIDE .
Cleaning Burner & Controls	Once annually	Qualified Service Technician	Brush or vacuum the control compartment, and burner areas surrounding the logs.
Checking Flame Patterns, Flame Height	Periodically	Qualified Service Technician/ Owner	Make a visual check of your stove's flame patterns. Make sure the flames are steady — not lifting or floating. See the picture in Figure 35. The thermopile/thermocouple tips should be covered with flame. See the picture in Figure 36.
Checking Flue System	Before initial use and at least annually thereafter, more frequently if possible	Qualified Service Technician/ Owner	Inspect the external terminal cap on a regular basis to ensure that no debris is interfering with the flow of air. Inspect entire flue system for proper function.
Cleaning Glass Door	After the first 3-4 hours of use. As necessary after initial cleaning.	Qualified Service Technician	Remove and clean glass after the first 3 to 4 hours of use. After the initial cleaning, clean as necessary, particularly after adding new ember material. Film deposits on the inside of the glass door should be cleaned off using a household glass cleaner. NOTE: DO NOT handle or attempt to clean the door when it is hot and DO NOT use abrasive cleaners.

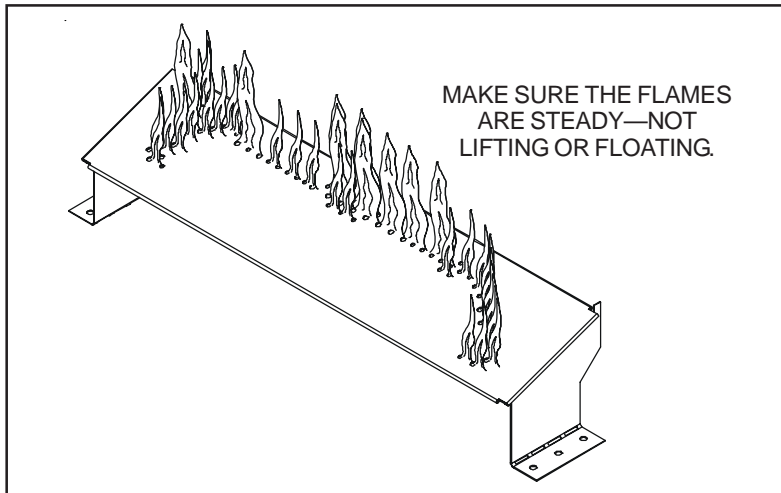

Figure 46. Burner Flame Patterns

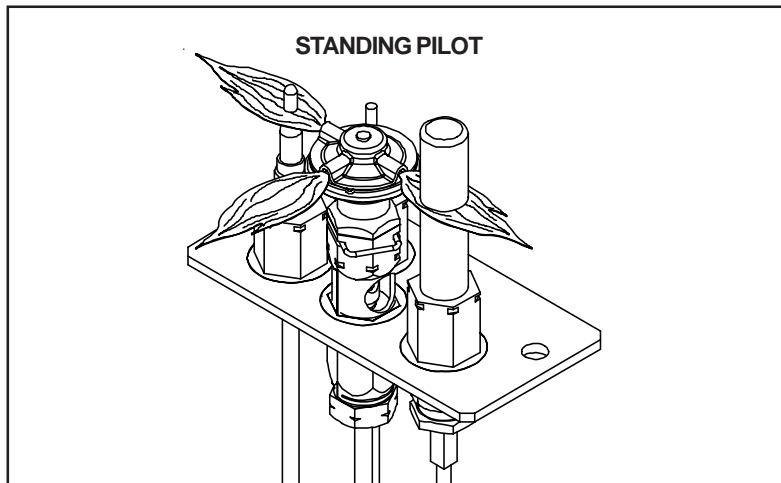

Figure 47. Pilot Flame Patterns

5

Trouble-shooting

With proper installation, operation, and maintenance your gas fireplace will provide years of trouble-free service. If you do experience a problem, this troubleshooting guide will assist a qualified service person in the diagnosis of a problem and the corrective action to be taken. This troubleshooting guide can only be used by a qualified service technician.

Standing Pilot Troubleshooting

Symptom	Possible Cause	Corrective Action
1. After repeated triggering of the red or black piezo button, the spark ignitor will not light the pilot.	<p>a. Defective ignitor</p> <p>b. Defective pilot or misaligned electrode (spark at electrode)</p> <p>c. No gas or low gas pressure</p> <p>d. No LP in the tank</p>	<p>Check the spark at the electrode and pilot. If no spark and electrode wire is properly connected, replace the ignitor.</p> <p>Using a match, light the pilot. If the pilot lights, turn off the pilot and trigger the red or black piezo button again. If the pilot lights, an improper gas/air mixture caused the bad lighting and a longer purge period is recommended. If the pilot will not light, ensure that the gap at the electrode and pilot is 3 mm to have a strong spark. If the gap is OK, replace the pilot.</p> <p>Check the remote shut-off valves from the fireplace. Usually, there is a valve near the gas main. There can be more than one (1) valve between the fireplace and the main.</p> <p>Check the LP (propane) tank. You may be out of fuel.</p>
2. The pilot will not stay lit after carefully following the lighting instructions.	<p>a. Defective thermocouple</p> <p>b. Defective valve</p>	<p>Check that the pilot flame impinges on the thermocouple. Clean and/or adjust the pilot for maximum flame impingement.</p> <p>Ensure that the thermocouple connection at the gas valve is fully inserted and tight (hand tighten plus 1/4 turn).</p> <p>Disconnect the thermocouple from the valve, place one millivolt meter lead wire on the tip of the thermocouple and the other meter lead wire on the thermocouple copper lead. Start the pilot and hold the valve knob in. If the millivolt reading is less than 15mV, replace the thermocouple.</p> <p>If thermocouple is producing more than 15 millivolts, replace faulty valve.</p>
3. The pilot is burning, there is no gas burner, the valve knob is in the ON position, and the ON/OFF switch is in the ON position.	<p>a. ON/OFF switch or wires defective</p> <p>b. Thermopile may not be generating sufficient millivoltage</p>	<p>Check the ON/OFF switch and wires for proper connections. Place the jumper wires across the terminals at the switch. If the burner comes on, replace the defective switch. If the switch is OK, place the jumper wires across the switch wires at the gas valve. If the burner comes on, the wires are faulty or connections are bad.</p> <p>If the pilot flame is not close enough physically to the thermopile, adjust the pilot flame.</p> <p>Be sure the wire connections from the thermopile at the gas valve terminals are tight and that the thermopile is fully inserted into the pilot bracket.</p>

Symptom	Possible Cause	Corrective Action
3. (Continued)	<p>c. Defective valve</p> <p>d. Plugged burner orifice</p> <p>e. Wall switch or wires are defective</p>	<p>Check the thermopile with a millivolt meter. Take the reading at TH-TP&TP terminals of the gas valve. The meter should read 325 millivolts minimum, while holding the valve knob depressed in the pilot position, with the pilot lit, and the ON/OFF switch in the OFF position. Replace the faulty thermopile if the reading is below the specified minimum.</p> <p>With the pilot in the ON position, disconnect the thermopile leads from the valve. Take a reading at the thermopile leads. The reading should be 325 millivolts minimum. Replace the thermopile if the reading is below the minimum.</p> <p>Turn the valve knob to the ON position. Place the ON/OFF switch in the ON position. Check the millivolt meter at the thermopile terminals. The millivolt meter should read greater than 125mV. If the reading is acceptable, and if the burner does not come on, replace the gas valve.</p> <p>Check the burner orifice for stoppage. Remove stoppage.</p> <p>Follow the corrective action in Symptom and Possible Cause 1. a. above. Check the switch and wiring. Replace where defective.</p>
4. Frequent pilot outage problem.	<p>a. Pilot flame may be too high or too low, or blowing (high), causing pilot safety to drop out</p>	<p>Clean and adjust the pilot flame for maximum flame impingement on thermocouple. Follow lighting instructions carefully.</p>

Symptom	Possible Cause	Corrective Action
5. The pilot and main burner extinguish while in operation.	<ul style="list-style-type: none"> a. No LP in the tank b. Inner flue pipe leaking exhaust gases back into the system c. Horizontal flue improperly pitched d. Glass too loose and air tight packet leaks in corners after usage e. Bad thermopile or thermocouple f. Improper flue cap installation 	<p>Check the LP (propane) tank. Refill the fuel tank.</p> <p>Check for gas leaks.</p> <p>The horizontal flue cap should slope down only enough to prevent any water from entering the unit. The maximum downward slope is 6 mm.</p> <p>Tighten the corner.</p> <p>Replace if necessary.</p> <p>Check for proper installation and freedom from debris or blockage.</p>
6. Glass soots.	<ul style="list-style-type: none"> a. Flame impingement b. Improper venturi setting c. Debris around venturi 	<p>Adjust the log set so that the flame does not excessively impinge on it.</p> <p>Adjust the air shutter at the base of the burner.</p> <p>Inspect the opening at the base of the burner. NO MATERIAL SHOULD BE PLACED IN THIS OPENING.</p>
7. Flame burns blue and lifts off burner.	<ul style="list-style-type: none"> a. Insufficient oxygen being supplied 	<p>Ensure that the flue cap is installed properly and free of debris. Ensure that the flue system joints are tight and have no leaks.</p> <p>Ensure that no debris has been placed in the area at the base of, or in the area of, the air holes in the center of the base pan beneath the burner.</p> <p>Ensure that the glass is tightened properly on the unit, particularly on top corners.</p>