

BOMANN®

User Manual

HOUSEHOLD- COOLING BOX WITH ICE BOX

KB 289

Please read this manual carefully and keep for future reference!



TABLE OF CONTENT

OVERVIEW	2
DISPOSAL OF USED DEVICES	2
IMPORTANT USE AND SAFETY INSTRUCTIONS	3
General safety precautions	3
Risk of injury	3
Coolant	3
Intended use	3
Unpacking	3
PRODUCT DESCRIPTION	4
Delivery scope	4
Specifications	4
INSTALLATION	5
Location	5
Electrical connection	5
REVERSE THE DOOR OPENING	5
STARTUP / OPERATION	6
Prior to first use	6
Turning on	6
Storing food	6
Defrosting	7
Operating noise	7
Turning off	7
TIPS FOR SAVING ENERGY	7
MAINTENANCE AND CLEANING	8
Cleaning and care	8
Repairs	8

OVERVIEW



Please read this user manual thoroughly before first time operation. It includes important information with regard to installation, operation and maintenance of the device. Improper use may cause hazardous situations, especially for children.

Keep this manual for future reference. Pass it on to any future owner of this product. In case of any doubt regarding questions or topics which are not extensively described in this manual, please contact your distributor or a authorized technician.

DISPOSAL OF USED DEVICES



This product is marked in accordance with the European waste regulation 2002 / 96 / EC - WEEE

It regulates the proper disposal of the product. Environmentally friendly disposal will prevent possible negative consequences to health caused by improper disposal.

This symbol on the product or its packaging indicates that this product must not be disposed of with the regular household waste. The user has to return the product to a collection point for the recycling of electric and electronic equipment.

The disposal must comply with the local regulations in place.

For further information please contact your local authorities or waste collection service.

Disable waste equipment before disposal:

- Disconnect the mains plug from the wall socket.
- Disconnect the plug from the mains cable.
- Remove or disable any existing spring or latch locks.
This will prevent children from locking themselves (risk of suffocation!) or from getting into perilous situations. Children might not understand the risks that arise from handling household devices. Therefore, observe children and make sure they do not play with the device.

IMPORTANT USE AND SAFETY INSTRUCTIONS

General safety precautions

All safety information in this user manual are marked with a warning symbol. They indicate possible dangers precociously. It is imperative to read and follow these information.

- Do not touch the plug at the mains cable with wet or moist hands when connecting or disconnecting. Risk of death by electric shock!
- In case of emergency, unplug the device immediately.
- Hold the plug when disconnecting the mains cable; do not pull the cable.
- Disconnect the plug before cleaning or servicing.
- Regularly check the device and cable for signs of damage. Do not continue to operate the device in case of damage.
- A damaged mains cable must be replaced by the manufacturer or a technician and without any delay. Do not use the device with a damaged cable or plug.
- Do not repair the device by yourself. Please contact authorized personnel. In order to avoid hazards. A damaged mains cable must be replaced with an equivalent cable by the manufacturer or qualified specialist.
- Except for cleaning and maintenance work described in this manual, no other alterations of this device must be executed.
- Do not place vases or other containers filled with liquids on the device.

Risk of injury!

- So that you can disconnect the appliance quickly in event of an emergency, do not use extension cables.
- This device may not be operated by children or persons with physical, sensory or mental abilities or lack of experience and knowledge, unless they are supervised or guided.
- Children should be supervised to ensure that they do not play with the device.
- Transport the unit never with content.

WARNING:

- Packaging materials (e.g. plastic bags, polystyrene) are dangerous for children. Risk of suffocation! Keep packaging materials out of reach of children.
- Containers with flammable gases or liquids can leak due to cold ambient temperatures. Risk of explosion! Do not store combustible materials such as aerosol cans or refill cartridges for lighters in your device.

Coolant

 **CAUTION:** The coolant circuit of this device contains the refrigerant Isobutane (R600a), a natural gas that is flammable and of high environmental compatibility. Make sure no parts of the Coolant circuit gets damaged during transport and installation of the device.

If the coolant circuit is damaged:

- it is imperative to avoid any open flames or ignition source.
- thoroughly air the room in which the device is installed.

Intended use

- This device is intended for private use. It is suitable for cooling food.
- The manufacturer is not reliable for any damage resulting from improper or other than intended use.
- For safety reasons, alterations or modifications of the device are prohibited.
- Please keep in mind that the manufacturer is not reliable for any damage resulting from commercial or any other use than cooling food.

Unpacking

The packaging must be undamaged. Check the device for any possible transport damage. Do not install a damaged device. In case of damage, please contact your distributor.

Packaging material

The packaging for transportation of the device and individual parts is produced of recyclable materials.

- corrugated cardboard / paperboard (mainly of waste paper)
- form part of PS (foamed, CFC-free polystyrene)

- Films and bags of PE (polyethylene)
- Strapping strips of PP (polypropylene)

⚠ IMPORTANT: Make sure you dispose of packaging materials environmentally friendly.

Removing the transport protection

The device and parts of the interior are protected for transport. Remove all adhesive tapes from the right and left side of the door. You may remove adhesive residue with a cleaning solvent. Also remove any adhesive tapes and packaging materials from the inside of the device.

PRODUCT DESCRIPTION

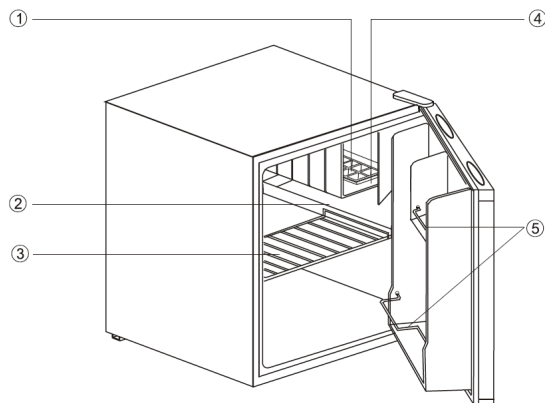

- 1 Ice-cube tray
- 2 Water drip pan
- 3 Removable grid shelf
- 4 Ice box
- 5 Door storage rack

Delivery scope

Removable grid shelf, ice-cube tray, water drip pan, user manual (D, GB)

Specifications

BOMANN Model No.	KB 289
Energy Efficiency class ⁽¹⁾	A+
Climate class ⁽²⁾	N-ST
Gross/net capacity, total	43/42 l
Net capacity fridge/freezer	36/6 l
Energy consumption ⁽³⁾	0.308 kWh/24h - 112 kWh/year
Connection voltage	220-240 V, 50 Hz
Connection power	70 W
Operating noise	43 dB(A)
Sizes H x W x D	51.0 x 43.9 x 47.0 cm
Gross / net weight	15.5 / 13.5 kg
Coolant	R600a

⁽¹⁾ A+++ (highest Efficiency) up to G (lowest Efficiency)

⁽²⁾ Climate class SN (Subnormal): ambient temperature of +10 °C up to +32 °C

Climate class N (Normal): ambient temperature of +16 °C up to +32 °C

Climate class ST (Subtropics): ambient temperature of +16 °C up to +38 °C

Climate class T (Tropics): ambient temperature of +16 °C up to +43 °C

⁽³⁾ The actual energy consumption depends on the use and installation of the device.

All device-specific data of the energy label have been determined by the manufacturer under laboratory conditions in accordance with pan-European standardized measuring methods. These are regulated by ISO EN 15502. The actual energy consumption depends on the usage and might therefore also be above the values determined by the manufacturer under standard conditions.

An expert knows these relations and will execute the tests with special measurement instruments in accordance with the regulations in place.

MANUFACTURER DATA: Product is subject to changes and improvements.

INSTALLATION

Location

Sufficient ventilation around the device is necessary in order for the heat to dissipate properly and to guarantee efficient cooling operation at low power consumption. For this purpose, leave sufficient space around the device.

- Minimum clearance of 7.5 cm between rear side and wall,
- at least 10 cm on both sides and 10 cm on top of the device.
- Leave proper space in front of the device in order to open the door at an angle of 160°.

IMPORTANT

- Do not expose the device to direct sunlight.
- Do not place near heaters, next to a stove or any other heat sources.
- Do not use the device outdoors.
- Only install at a location with an ambient temperature suitable for the climate class of the device. For information on the climate class, please refer to chapter "Specifications" or to the rating label located in the interior or on the rear side of the device.
- Avoid installation at locations with high humidity (e.g. outdoors, bathroom), as metal parts would be susceptible to corrosion under such circumstances.
- Do not place the device near volatile or combustible materials (e.g. gas, fuel, alcohol, paint, etc.) and in rooms which may have poor air circulation (e.g. garages).
- Only place on a steady and safe surface.
- If the device is not horizontally leveled, adjust the feet accordingly.

Electrical connection

The kind of current (AC) and the voltage must be conform with the data of the rating label, located inside or outside on the back of the unit. In case of heavy voltage fluctuations, it is recommended to use an automatic alternating current regulator.

The plug, together with the grounding conductor, must fit into the wall socket. The mains plug must be freely accessible.

Mains cable

- Do not extend or roll up the cable during operation.
- Also, the cable must not be near the compressor on the rear side, since latter one gets hot during operation. In case of any contact, the isolation would be damaged resulting in electric leakage.
- The use of extension cables is not recommended.
- Do not connect the device to the mains with wet hands.
- Install the device for the wall socket to be freely accessible.

REVERSE THE DOOR OPENING

If required, the door opening can be moved from the right (supplied condition) to the left side.

 **WARNING:** When replacing the door stop, the device must be disconnected from the power supply. Always unplug the device first.

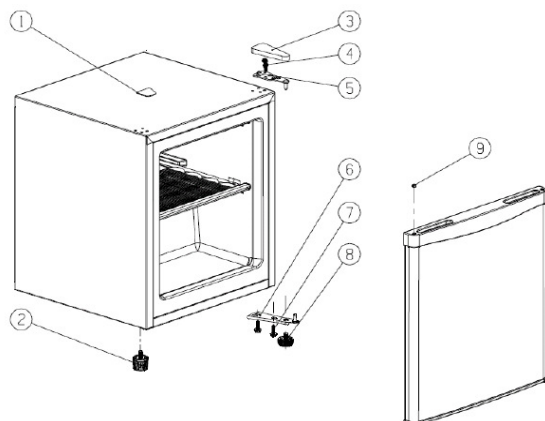

- (1) Blind plug
- (2) Separate Foot
- (3) Hinge cover
- (4) Screws
- (5) Upper door hinge
- (6) Lower door hinge
- (7) Screws
- (8) Foot
- (9) Blind plug

- Use a screw-driver to remove the hinge cover (3) and the blind plug (1).
- Tilt the device slightly backwards and block it in this position.

- Dismount the upper door hinge (5) by unscrewing the screws (4).
- Open the door a little and take it carefully from the lower door hinge (6).
- Remove the blind plug (9), put it at the uncovered hole at the opposite side and place the door on a padded surface to prevent it from scratches.
- Take off the separate foot (2) and dismount the lower door hinge (6) incl. foot (8) by unscrewing the screws (7).
- Move the lower hinge (6) incl. foot (8) to the opposite device side and fix it with the screws (7).
- Screw the separate foot (2) on the corresponding opposite side again.
- Replace the device in the upright position again. Insert the device door on the pin of the lower door hinge (6) and fix the door to the property position.
- Attach the upper door hinge (5) by using the screws (4) to the corresponding opposite side.
- Put the at the beginning removed blind plug (1) to the uncovered hole on the opposite side and clip the hinge cover (3) on again.

Check if the door is arranged vertical as well as horizontal, so that a smooth opening and closing of the door is ensured.

STARTUP / OPERATION

Prior to first use

⚠ ATTENTION: After transport, the device should be left standing for 4 hours in order for the oil to be collected in the compressor. Nonobservance could cause damage to the compressor and hence result in failure of the device. This would void your warranty claim.

- Clean the interior of the device including all accessory parts located inside.

Connect the device to the mains supply

⚠ IMPORTANT:

- The device must be earthed properly. For this purpose the plug of the mains cable has been fitted with the intended lead.
- Contact an electrician if the plug does not fit in the wall socket.
- In case you disconnect the device or in case of power failure: Wait for 5 minutes before restarting the device.

Turning on

Turn on the device by connecting the plug to a wall socket and turning the temperature control, which is located in the interior. Please also refer to chapter "Settings".

Settings

Setting 0 indicates the device is turned off. Turn the temperature control clockwise, starting from this setting; the device will turn on automatically. The Settings 1 MIN – 5 MAX regulate the inside temperature.

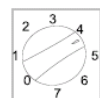

Setting 0	=	Off
Setting 1 (or MIN)	=	lowest setting (warmest inside temperature)
Setting 7 (or MAX)	=	highest setting (coldest inside temperature)

Turning the temperature control clockwise will lower the inside temperature. Please keep in mind that the temperature changes with the ambient temperature (of the location), with the frequency of opening the door and the amount of food in the device.

During initial operation, turn the temperature control to the highest setting first, until the device has reached the desired operating temperature. Afterwards It is recommended to turn the control back to a medium setting, correcting the temperature at a later point would then be easier.

Storing food

Note: Always store food covered or packed in order to prevent drying-out and transfer of odor or taste onto other food items.

You may pack the food with:

- Polyethylene plastic bags or foil
- Plastic containers with a lid
- Special elasticated plastic covers
- Aluminum foil

The following safety precautions are recommended

- The device is suitable for storing fresh food and drinks.
- Store fresh packed items on the glass shelves and fresh fruits and vegetables in the vegetable box.
- Place bottles in the shelf of the door.
- Store meat well packed and only for 2 to 3 days. Avoid contact with cooked dishes.
- Let warm food cool down before putting it in the device.

Ice Box

The ice box allows you to store already frozen food at a temperature up to -4°C short term. Pls. also refer to the recommended storage data on the packaging of the frozen food. But the freezing box is especially provided for the preparation of ice cubes.

Defrosting

To achieve better cooling and to save energy, defrost the device regularly. To start the defrosting process turn the temperature control to the position 0 – OFF and disconnect the plug. Remove the food items and keep covered at a cool location. When the ice has melted, pour the condensate away and dry the interior of the device. You may then restart the device by connecting the plug and turning the temperature control.

 **WARNING:** Never use metal objects (e.g. knives) for removing ice from the vaporizer. The vaporizer could be damaged. A defect vaporizer could cause serious damages.

Operating noise

	TYPE OF SOUND	CAUSE/ SOLUTION
NORMAL NOISE	Mumbling	Caused by the compressor during its operation. This is stronger when it turns on or off.
	Liquid sounds	Caused by the circulation of the refrigerant in the device.
	Click sounds	The temperature control turns the compressor on or off.
	Disturbing noises	Vibration of the shelves or cooling coils – check if those are securely fastened.

Turning off

Turn the temperature to setting 0 – OFF in order to turn off the device.

If the device will not be operated for a longer period of time:

- Remove the entire food from the device.
- Turn the temperature control to setting 0 – OFF.
- Disconnect the plug or turn off / unscrew the fuse.
- Thoroughly clean the device (refer to chapter of “Cleaning and Care”).
- Keep the door open in order to prevent bad odors.

TIPS FOR ENERGY SAVING

- Disconnect the plug if you do not use the device.
- Do not install the device near stoves, heaters or other heat sources. In case of higher ambient temperatures, the compressor will run more frequently and longer.
- Ensure sufficient ventilation at the bottom and rear side of the device. Never block any ventilation openings.
- Allow warm dishes to cool down before putting them in the device.
- Do not open the door longer than necessary.
- Only set the temperature as low as needed. The ideal temperature is 7°C.
- The device should be defrosted regularly.
- Make sure the door sealing is in good order for the door to close properly.

MAINTENANCE AND CLEANING

Cleaning and Care

For hygienic reasons, clean the interior and accessory parts regularly.

WARNING:

- Always disconnect the plug or turn off/ unscrew the fuse before cleaning. Pull the plug and not the cable.
- Do not use steam cleaners for cleaning the device; moisture could enter electrical components. Risk of electric shock! Hot steam could damage the plastic parts. The device must be dry before restarting operation.
- Essential oils and organic solvents, such as the juice of lemon or orange skin, butanoic acid or cleaning agents containing acetic acid can damage plastic parts. Prevent contact of any part with such substances. Do not use abrasive cleaning agents.

Pls. do as follows:

- Remove all food and keep covered at a cool location.
- Use warm water and a mild detergent for cleaning the interior (including rear side and bottom).
- After thorough drying, restart operation.

WARNING

- Do not bend the cooling coils.
- Do not use arenaceous abrasives.

Repairs

 **WARNING:** Servicing of electric devices must be conducted by qualified experts only. Incorrect or improper repairs constitute a risk for the user and will void the warranty!

What if . . . Troubleshooting

The design of the device ensures a trouble-free operation as well as a long life cycle. Nevertheless, if any defect occurs during operation, please check if it is caused by improper operation.

The following problems can be solved by you by checking for the possible cause.

PROBLEM	POSSIBLE CAUSE	SOLUTION
The device is not working properly or at all	Is the plug securely connected to the mains? Has the safety mechanism of the wall socket been triggered? Is the temperature control properly set? Is the place unqualified? Do food items or shelves and/or drawers prevent the door from closing properly? Is the ventilation of the device hedged?	Connect the plug properly to the socket, turn on the fuse, and contact a technician if necessary. Check the settings. Check the ambient temperature. Arrange the food or shelves and/or drawers properly. Clear the ventilation slits, install the device freely
Loud noise during operation	Does the device not stand vertical or horizontal?	Adjust the feet accordingly. Liquid flow sounds in the cooling circuit are normal.
Water on the bottom	Is the temperature control set properly?	Check the temperature settings.

Note. On days of high humidity, condensation might occur on the outer surface of the device. This is no malfunction; you may simply wipe the water off.

If a problem still persists after following the steps above, please contact your distributor or a technician.

Are you interested in other Bomann products? Please visit our website:

www.bomann.de