

PicoLAS

FOCUSSING POWER TO THE POINT

User Manual - preliminary - Rev. 12.09

LDP-C 80-20

LDP-CW 80-20

LDP-C 80-40

LDP-CW 80-40

LDP-C 120-20

LDP-CW 120-20

LDP-C 120-40

LDP-CW 120-40

This manual is for all pulsed C and continuous current CW driver units above.

Please note the specifications are different for different units. In case of doubt please refer to the corresponding data sheet.

Before powering on your unit, read this manual and make sure you understood it fully. Please pay attention to all safety warnings.

If you have any doubt or suggestion, please do not hesitate to contact us!

PicoLAS GmbH

Company for Innovative Power Electronics und Laser Technology

Kaiserstraße 100
52134 Herzogenrath

Tel: +49(0)2407-563 58-0
Fax: +49(0)2407-563 58-29
E-Mail: info@picolas.de
Web: www.picolas.de



Table of Contents

Table of Contents 2
 Specifications 3
 Description of Connections and Jumpers 5
 Interface Specification 6
 Timing Diagram 8
 Dos and Don'ts 10
 Functional Description 11
 Test Load 12
 Power Supply 12
 Cooling 12
 Over Temperature Shutdown 13
 Soft Start 13
 Mechanical Dimensions 13
 Power on self test 15
 Controlling the driver 16
 Trigger Modes 16
 Controlling the LDP-C 120-20 using a PLB-21 18
 Controlling the LDP-C 120-20 via USB 20
 Register description 32

Specifications

LDP-C 80-20

Output current	2 .. 80 A
Max. compliance voltage	20 V
Max. output power	1600 W
Min. Pulsewidth	< 4 μ s **
Max. Pulsewidth	CW
Risetime	1 .. 5 μ s **
Max. Reprate	> 80 kHz **
Current ripple	< 1 A
Current overshoot	< 5 %
Current settling time	< 1 ms
Current setting input	
Current monitor	0 .. 2.0 V external (50 A/V)
Voltage monitor	50 A/V **
Connectivity	0.1 V/V ** LDP-C BOB PLB-21
Supply voltage	USB 2.0 4 .. 26 V DC (at least 2 V above compl. voltage)
Dimensions in mm	
Operating temperature	100 x 180 x 100
Weight	0 to + 55 °C Ca. 1.2 kg

LDP-C 120-20 specs to be corrected

Output current	10 .. 120 A
Max. compliance voltage	20 V
Max. output power	2400 W
Current ripple	< 1 %
Current overshoot	< 1 %
Analog modulation (100 A _{pp})	< 4 kHz **
Current settling time (full-scale)	< 100 μ s
Current setting input	0 .. 2.4 V external (50 A/V)
Current monitor	50 A/V **
Voltage monitor	0.05 V/V **
Connectivity	LDP-C BOB PLB-21 USB 2.0
Supply voltage	24 V DC (at least 3 V above diode laser voltage)
Power dissipation @ 120 A / 12 V diode voltage	150 W
Dimensions in mm	103 x 180 x 69
Weight	850 g
Operating temperature	0 to + 55 °C

LDP-C 80-40 specs to be corrected

Output current	2 .. 80 A
Max. compliance voltage	20 V
Max. output power	1600 W
Min. Pulsewidth	< 4 μ s **
Max. Pulsewidth	CW
Risetime	1 .. 5 μ s **
Max. Reprate	> 80 kHz **
Current ripple	< 1 A
Current overshoot	< 5 %
Current settling time	< 1 ms
Current setting input	
Current monitor	0 .. 2.0 V external (50 A/V)
Voltage monitor	50 A/V **
Connectivity	0.1 V/V ** LDP-C BOB PLB-21
Supply voltage	USB 2.0 4 .. 26 V DC (at least 2 V above compl. voltage)
Dimensions in mm	
Operating temperature	100 x 180 x 100
Weight	0 to + 55 °C Ca. 1.2 kg

LDP-C 120-40 specs to be corrected

Output current	10 .. 120 A
Max. compliance voltage	20 V
Max. output power	2400 W
Current ripple	< 1 %
Current overshoot	< 1 %
Analog modulation (100 A _{pp})	< 4 kHz **
Current settling time (full-scale)	< 100 μ s
Current setting input	0 .. 2.4 V external (50 A/V)
Current monitor	50 A/V **
Voltage monitor	0.05 V/V **
Connectivity	LDP-C BOB PLB-21 USB 2.0
Supply voltage	24 V DC (at least 3 V above diode laser voltage)
Power dissipation @ 120 A / 12 V diode voltage	150 W
Dimensions in mm	103 x 180 x 69
Weight	850 g
Operating temperature	0 to + 55 °C



LDP-CW 80-20

Output current	2 .. 120 A
Max. compliance voltage	20 V
Simmercurrent	0 .. 120 A **
Max. output power	2400 W
Current ripple	< 1 A
Current overshoot	< 1 %
Analog modulation (100 A _{pp})	< 4 kHz **
Current settling time (full-scale)	< 100 µs
Current setting input	0 .. 2.4 V external (50 A/V)
Current monitor	50 A/V **
Voltage monitor	0.1 V/V **
Connectivity	LDP-C BOB PLB-21 USB 2.0
Supply voltage	15 .. 26 V DC (at least 1 V above compl. voltage)
Power dissipation @ 120 A / 12 V	150 W
Dimensions in mm	100 x 180 x 58
Weight	760 g
Operating temperature	0 to + 55 °C

LDP-CW 120-20

Output current	2 .. 80 A
Max. compliance voltage	20 V
Simmercurrent	2 .. 80 A **
Max. output power	1600 W
Current ripple	< 1 A
Current overshoot	< 1 %
Analog modulation (60 A _{pp})	> 2 kHz **
Current settling time (full-scale)	< 150 µs
Current setting input	0 .. 1.6 V external (50 A/V)
Current monitor	50 A/V **
Voltage monitor	0.1 V/V **
Connectivity	LDP-C BOB PLB-21 USB 2.0
Supply voltage	4 .. 26 V DC (at least 1 V above compl. voltage)
Power dissipation @ 80 A / 12 V	90 W
Dimensions in mm	100 x 180 x 58
Weight	760 g
Operating temperature	0 to + 55 °C

LDP-CW 80-40 specs to be corrected

Output current	2 .. 80 A
Max. compliance voltage	20 V
Simmercurrent	2 .. 80 A **
Max. output power	1600 W
Current ripple	< 1 A
Current overshoot	< 1 %
Analog modulation (60 A _{pp})	> 2 kHz **
Current settling time (full-scale)	< 150 µs
Current setting input	0 .. 1.6 V external (50 A/V)
Current monitor	50 A/V **
Voltage monitor	0.1 V/V **
Connectivity	LDP-C BOB PLB-21 USB 2.0
Supply voltage	4 .. 26 V DC (at least 1 V above compl. voltage)
Power dissipation @ 80 A / 12 V	90 W
Dimensions in mm	100 x 180 x 58
Weight	760 g
Operating temperature	0 to + 55 °C

LDP-CW 120-40 specs to be corrected

Output current	2 .. 120 A
Max. compliance voltage	20 V
Simmercurrent	0 .. 120 A **
Max. output power	2400 W
Current ripple	< 1 A
Current overshoot	< 1 %
Analog modulation (100 A _{pp})	< 4 kHz **
Current settling time (full-scale)	< 100 µs
Current setting input	0 .. 2.4 V external (50 A/V)
Current monitor	50 A/V **
Voltage monitor	0.1 V/V **
Connectivity	LDP-C BOB PLB-21 USB 2.0
Supply voltage	15 .. 26 V DC (at least 1 V above compl. voltage)
Power dissipation @ 120 A / 12 V	150 W
Dimensions in mm	100 x 180 x 58
Weight	760 g
Operating temperature	0 to + 55 °C

Connecting and Interfacing

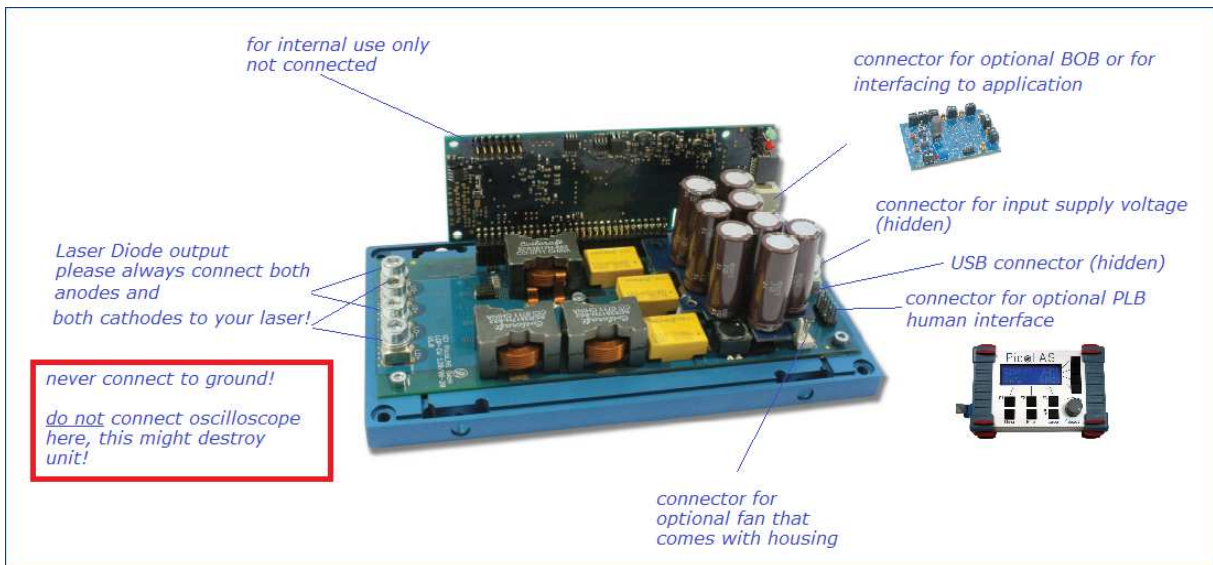

The above picture might differ in some minor details from your model.

The following drawing shows all connections which are available to the user.

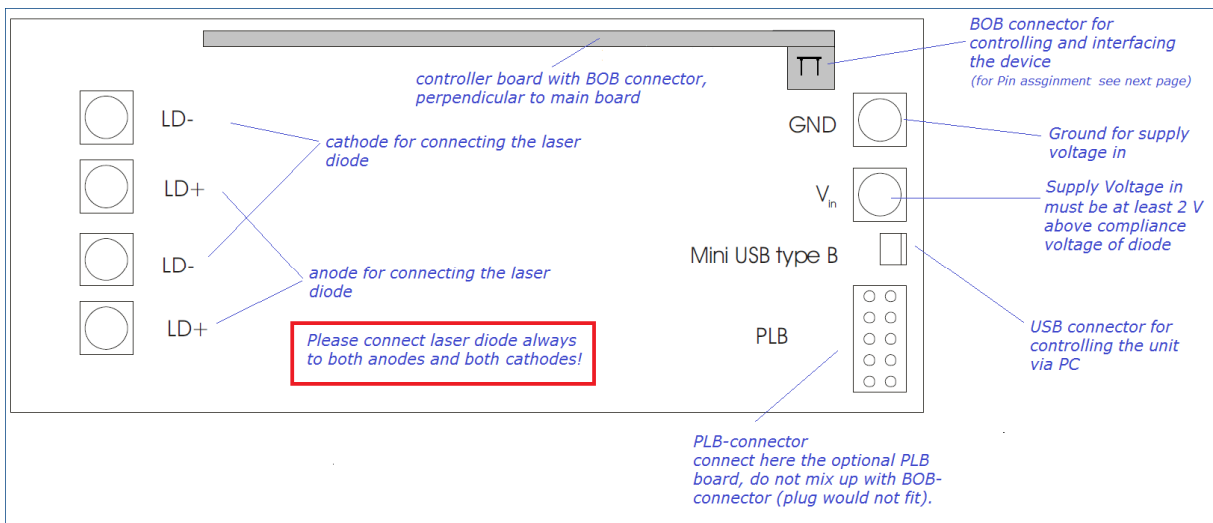

LDP-C BOB Connector	See section interface specifications for detailed information. (Break-Out-Board connector.)
PLB	Connector for PLB-21 human interface (protected against polarity reversal)
V_{in}	Supply voltage (5..24V) must be 2 V above laser diode compliance voltage
GND	Supply ground
LD+	Positive laser diode output (anode). It is highly recommended to use both connectors parallel, especially for high currents.
LD-	Negative laser diode output (cathode). Do not connect to ground It is highly recommended to use both connectors parallel, especially for high currents.
Mini USB	Mini USB connector for linking the driver to a computer.

For a more convenient use of the driver (e.g. in laboratory use) we recommend the optional available product accessory LDP-C-BOB or the PLB-21. Please see LDP-C-BOB and PLB-21 manual for further details.

Interface Specifications

The following figure shows the input and output signals of the external analogue BOB connector. This connector can be found on the perpendicular circuit board on the right side as shown on the previous page.

The BOB (Break Out Board) is recommended for easy testing of the driver. It will be replaced in the application by your machine interface. The PLB-21 is a human interface that allows for full control of all relevant device parameters.

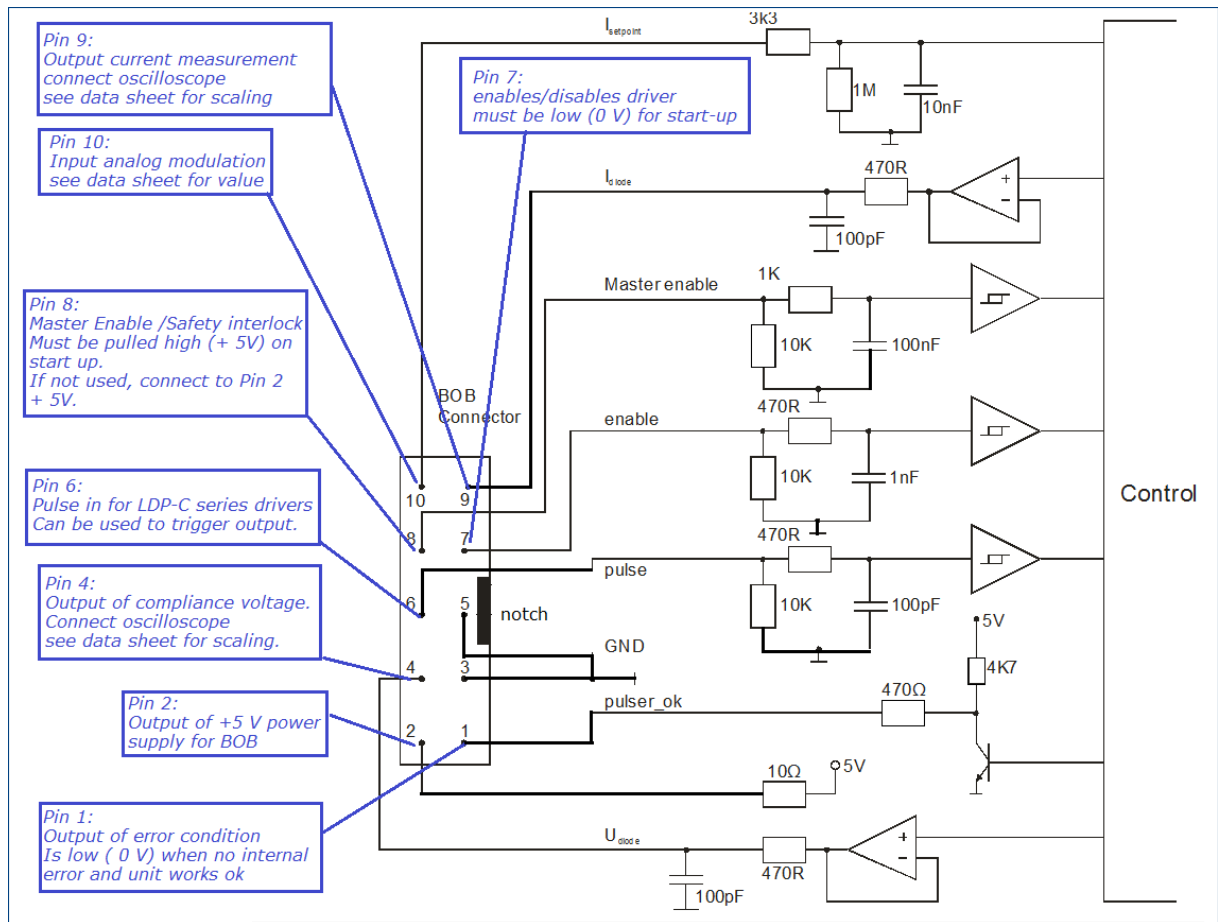

Functional Description of BOB-Connector Interface

Settings and Readings

I_{setpoint} (Pin 10) **to be completed**

This input signal is used to provide an **analogue setpoint value (amplitude modulation)**. In order to use the analogue setpoint, it must be configured in the PC via USB or the PLB. Please apply a voltage corresponding to the desired current settings according to the following table:

LDP-C 80-20 : 50 A/V, range 0 - 2.0 V	LDP-CW 80-20 : 50 A/V, range 0 - 1.6 V
LDP-C 80-40 : 50 A/V, range 0 - 1.6 V tbd	LDP-CW 80-40 : 50 A/V, range 0 - 1.6 V tbd
LDP-C 120-20 : 50 A/V, range 0 - 1.6 V tbd	LDP-CW 120-20: 50 A/V, range 0 - 2.4 V
LDP-C 120-40 : 50 A/V, range 0 - 1.6 V tbd	LDP-CW 120-40: 50 A/V, range 0 - 2.4 V

I_{diode} (Pin 9)

This signal is used as an output signal of the internal **current** shunt. It provides near real-time measurement of the output current. Connect your scope and take into account the following scaling:

50 A/V

U_{diode} (Pin 4)

This signal is used to determine the compliance **voltage** of the connected load. It provides near real-time measurement. Connect your scope and take into account the following scaling:

0.1 V/V

Master Enable (MEN) (Pin 8)

The Master Enable provides a safety interlock which disables the driver when pulled low.

This signal must be pulled high by the user for the driver to start up. If the signal is low when the driver is powered on, it will not work properly.

It is recommended that the user also disables the ENABLE after disabling MEN. Otherwise there will be a current overshoot on the connected load.

When no safety interlock is needed this signal can be connected to pin 2 of the BOB connector.

Enable (Pin 7)

The ENABLE signal enables / disables the driver during normal operation. The ENABLE signal must be pulled low by the user in order for the driver to start up. If the signal is high when the driver is powered on it will not work properly.

After the user applies the ENABLE signal, the internal current regulator ramps the current flow to the configured setpoint in a configured amount of time (soft start).

Pulse (Pin 6)

This signal is only used by the LDP-C. It provides fast access to the output stage and can be used to pulse the output current. Its actual usage depends on the configured trigger mode. Please see chapter "Trigger modes" for more details.

Pulser OK (Pin 1)

This signal informs the user about any error condition. It is pulled low by the driver when no internal error is detected.

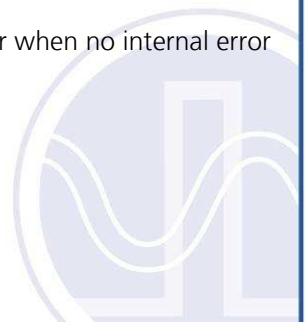

Timing Diagram

The following diagram shows the effect of the MEN, ENABLE and PULSE input signals to the internal end external current flow:

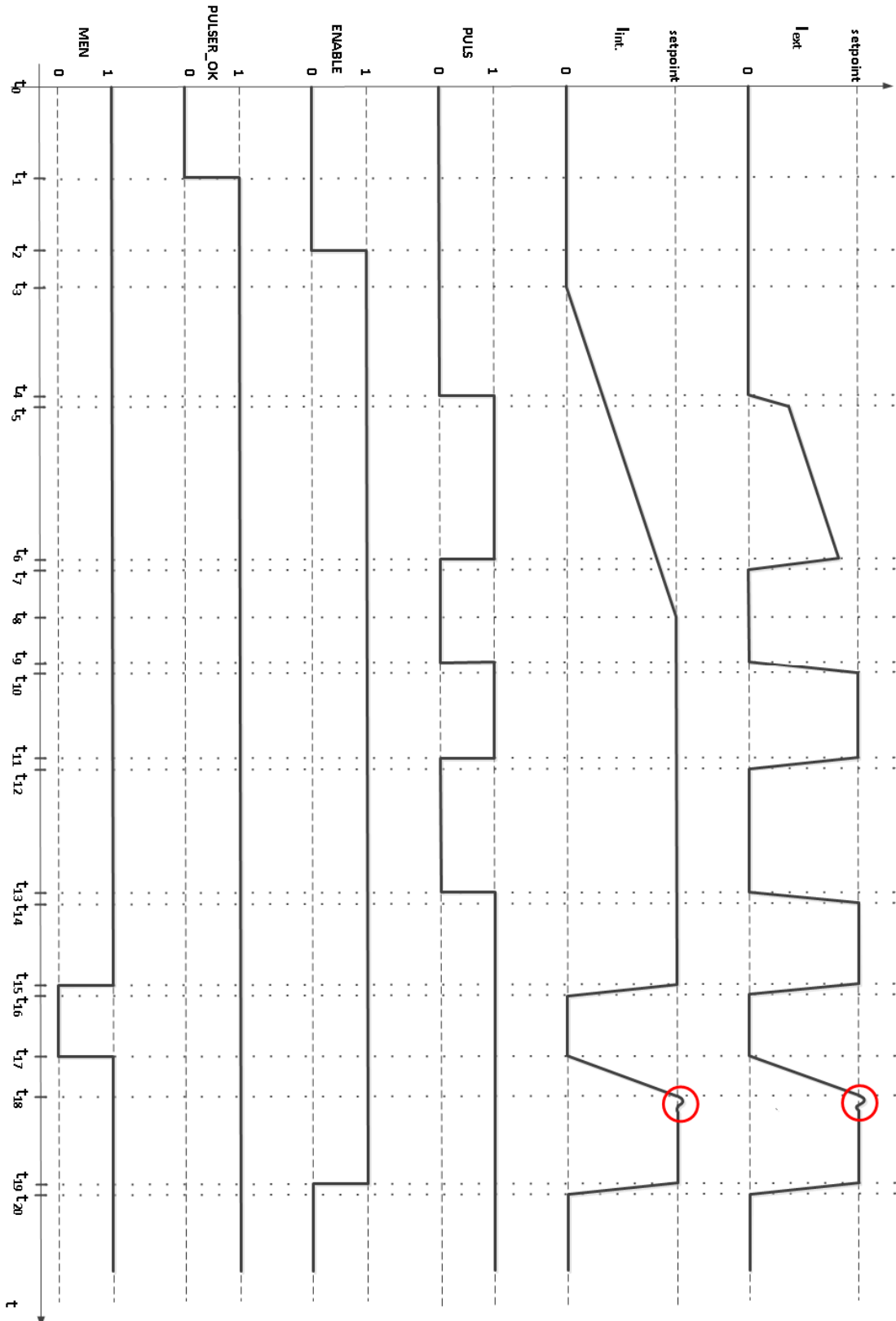

	meaning	min	max	avg.	notes
$t_0 - t_1$	Power on self test	2.5s	14s	4s	
$t_2 - t_3$	ENABLE delay	650us	5.5ms		
$t_3 - t_8$	soft start	166us	4.3ms		user configurable
$t_4 - t_5$ $t_9 - t_{10}$ $t_{13} - t_{14}$	rise time	1us			depends on the inductance of the connected load
$t_6 - t_7$ $t_{11} - t_{12}$ $t_{15} - t_{16}$ $t_{19} - t_{20}$	fall time				depends on the inductance of the connected load
$t_{17} - t_{18}$	rise time after MEN toggle				depends on the inductance of the connected load



Dos and Don'ts

Never ground any output connector. This may result in an incorrect current regulation!

Never use any grounded probes at the output. **Do not** connect your oscilloscope to the output! This will immediately destroy the driver and the probe!
For measuring current and voltage you connect the scope to Pin 9 or Pin 4 respectively.

Never make a short at the output. This will not do any harm to the laser driver but will result in an incorrect current measurement.

Keep connecting cables between power supply and driver as well as the connection between driver and laser diode as short as possible.

Mount the driver on an appropriate heat sink!



Do never connect the oscilloscope to the output connectors !!!

Functional Description

The driver operates with three parallel buck converters (S_1, S_2, D_1, D_2, L_1 ; S_3, S_4, D_3, D_4, L_2 ; S_5, S_6, D_5, D_6, L_3). Every single converter has an independent control loop with a current sensor (I_{meas1} , I_{meas2} and I_{meas3}). The set point current that is defined by the user is evenly spread over all three converters. The current through the laser diode is measured directly at the output pins with the help of a shunt resistor.

Inductor current (additional current of all three phases), laser diode current and compliance voltage are pre-processed and then fed into to the external BOB-connector. An enable-input as well as a status output are available.

Several security features protect the laser diode and driver from damage. D_8 protects the laser diode from reverse currents, S_7 could short the output pins and the bypass diode D_7 protects the driver in case of a load failure. To protect the laser diode during start-up of the driver, S_0 remains opened until the supply voltage has reached a stable level. In case of a failure, the control unit disables the driver. A soft-start mechanism slowly rises the current after an over temperature shutdown or at start-up.

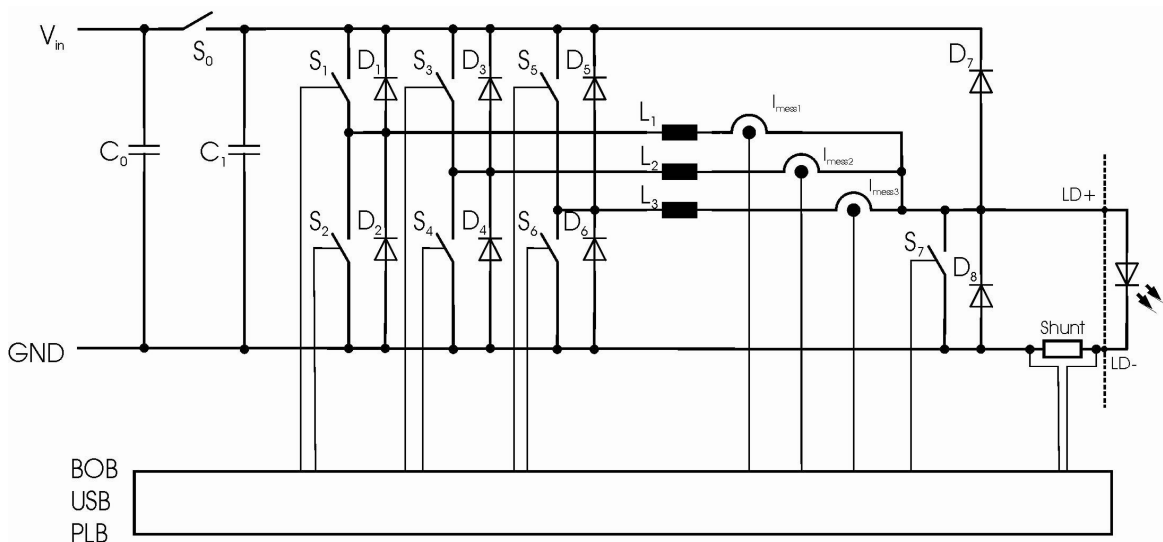

Operation Principle of LDP-C 120-20 driver

Element	Function
S_0	Security Switch
$C_1, S_1, S_2, S_3, S_4, S_5, S_6, D_1, D_2, D_3, D_4, D_5, D_6, L_1, L_2, L_3$	Buck Converter
C_0	Input Buffer Capacitor
S_7	Shunt MosFETs Short Output
D_7, D_8	Laser diode and driver protection diodes
Shunt	LD-current monitor

Test Load

A common method to test the driver is to connect a regular silicon rectifier diode to the driver output. Attention has to be paid to the junction capacitance of the diode. Only fast recovery diodes (or similar) have as low a parasitic capacitance as laser diodes have. To achieve reasonable test results, the parasitic elements of the test diode and the connection must be very similar to a laser diode. Regular silicon rectifier diodes have a junction capacitance of several microfarads and are not a suitable test load! The use of these diodes will result in incorrect current measurement at the pulse edges!

Power Supply

To obtain a good pulsing performance with the driver, it requires an appropriate power supply unit (PSU). The PSU has to supply not only the power that is delivered to the laser diode but also the power to compensate for the losses in the driver itself. Please take into account that the laser diode power varies strongly when the output current is modulated. Although the driver is equipped with a large input capacitance of 12 mF to buffer these power peaks, the power supply has to deliver the required power fast enough to avoid input voltage drops. For excessive modulation of the output current, the PSU output impedance as well as the line impedance between PSU and diode driver has to be as low as possible.

When the input voltage drops below 11.5 V the driver shuts down automatically. To remove this condition the enable line has to be toggled (switched off and on again).

Cooling

The driver produces up to 130 W of losses. Thus the base plate has to be mounted on a heat sink to ensure proper operation and prevent an over temperature shutdown. If working with high currents above 90 A it is recommended to cool the power inductors as well. This can be achieved easily by placing the diode driver with its heat sink in the air flow of a fan.

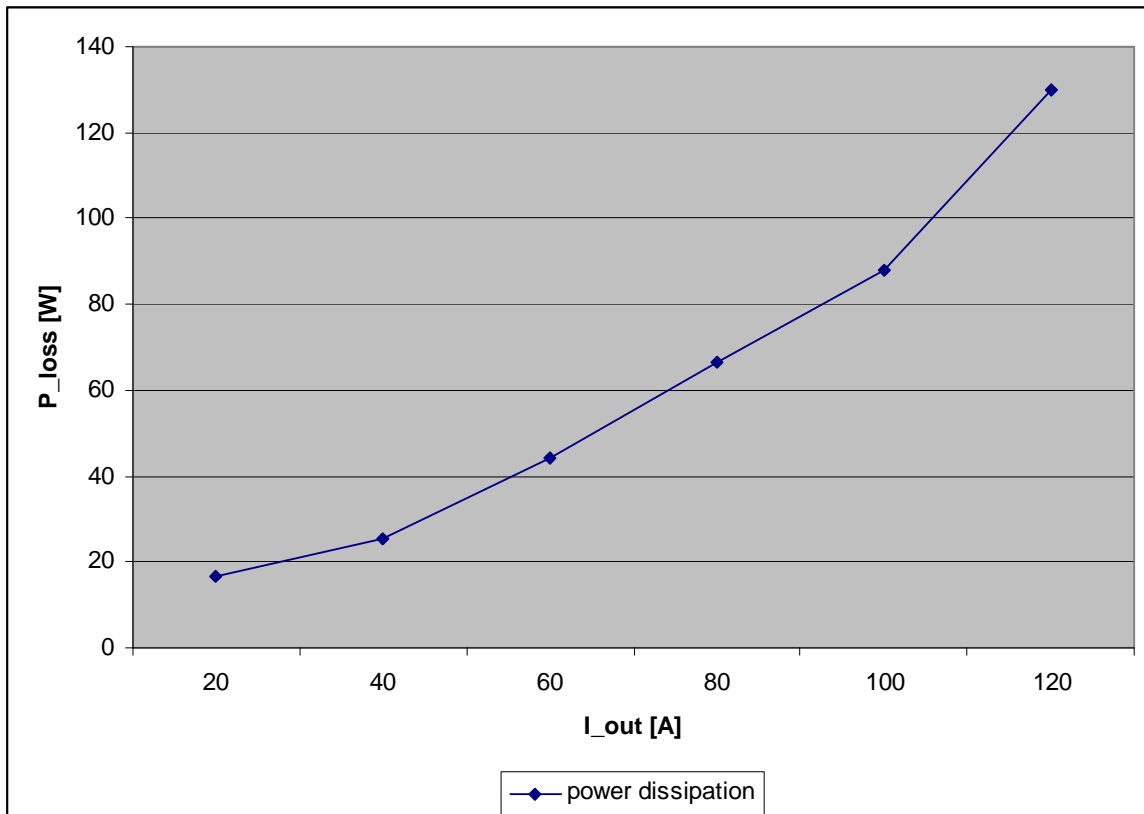

Power dissipation as a function of output current

Over Temperature Shutdown

To protect the laser diode and the driver itself, the unit automatically disables itself if its temperature rises above the configured shutdown temperature. This condition is latched and the diode driver will not start working until temperature drops five degrees below the shutdown temperature and the ENABLE-pin is toggled. During the over temperature shutdown, the PULSER_OK output (Pin 1 of the BOB-Connector) is pulled low. The shutdown temperature can be modified using a PLB-21 or via the USB connector.

Soft Start

The driver implements a soft start mechanism, which is activated every time the output is enabled via the ENABLE pin or the L_ON bit in the LSTAT register. This mechanism ramps up the current output from zero the setpoint in a configurable amount of time.

LED blink codes

The driver has two status LEDs located above the BOB connector. The green LED indicates the readiness; the red LED an error condition of the driver. The following table shows the meaning of the different blink codes:

Nr	green LED	red LED	meaning	solution
1	on	off	normal operation	--
2	blink 1x	off	stand by	--
3	blink 2x	off	power on self test	--
4	off	off	driver has no power supply	switch power on
5	off	on	when self test has been completed: power self test failed	contact your distributor
6	off	on	when driver was on before: over temperature shutdown	set ENABLE low and wait until the driver cooled down
7	off	blink 1x	temperature warning	
8	off	blink 2x	crowbar defect	contact your distributor
9	off	blink 3x	VCC too high	decrease VCC to normal levels
10	off	blink 4x	VCC too low	increase VCC to normal levels
11	off	blink 5x	VCC drops during operation	make sure the power supply provides enough current
12	off	blink 6x	either a shortcut or open clamps on the output detected (if enabled by the user)	remove shortcut on the output and check the connected load
13	off	blink 7x	safety switch S_0 failed	contact your distributor

Mechanical Dimensions

Over all height: 69,0 mm
All dimensions in mm

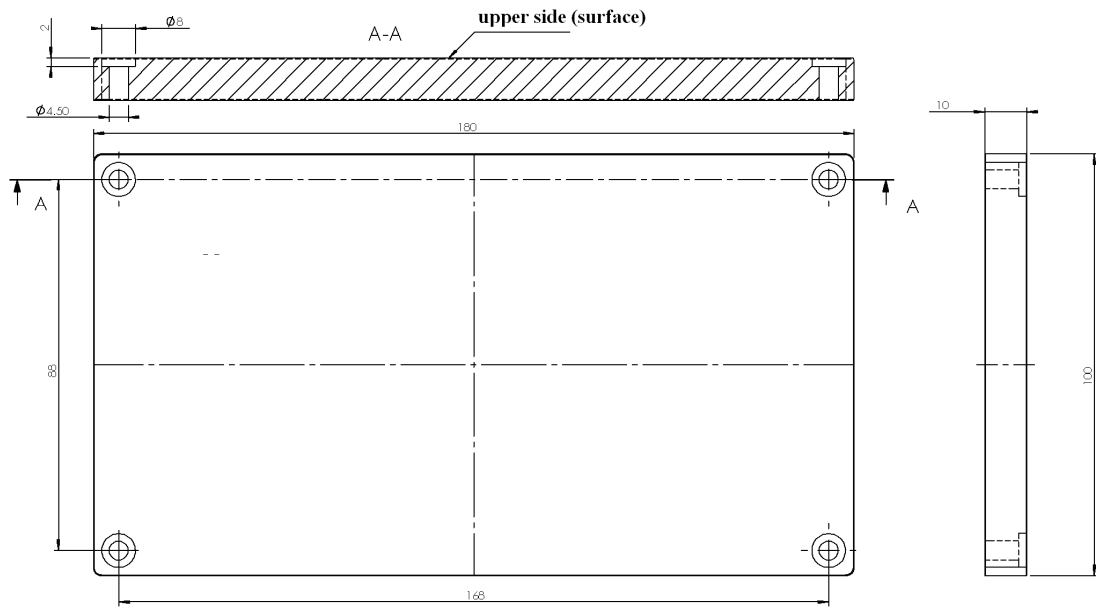

Power on self test

Each time the driver is powered on it performs a test of its internal safety features. **The MEN pin has to be HIGH, while the ENABLE pin has to be LOW for the self test to work properly.** Changing either of the signals during the self test will result in a failure. The driver cannot be enabled until a self test has been performed successfully. The PULSER_OK signal will be pulled high when the test has been successful.

The test will take less than 5 seconds, but can take up to 15 seconds due to internal time-outs if any failure is detected.

The following diagram shows the individual tests and the approximate time it will take:

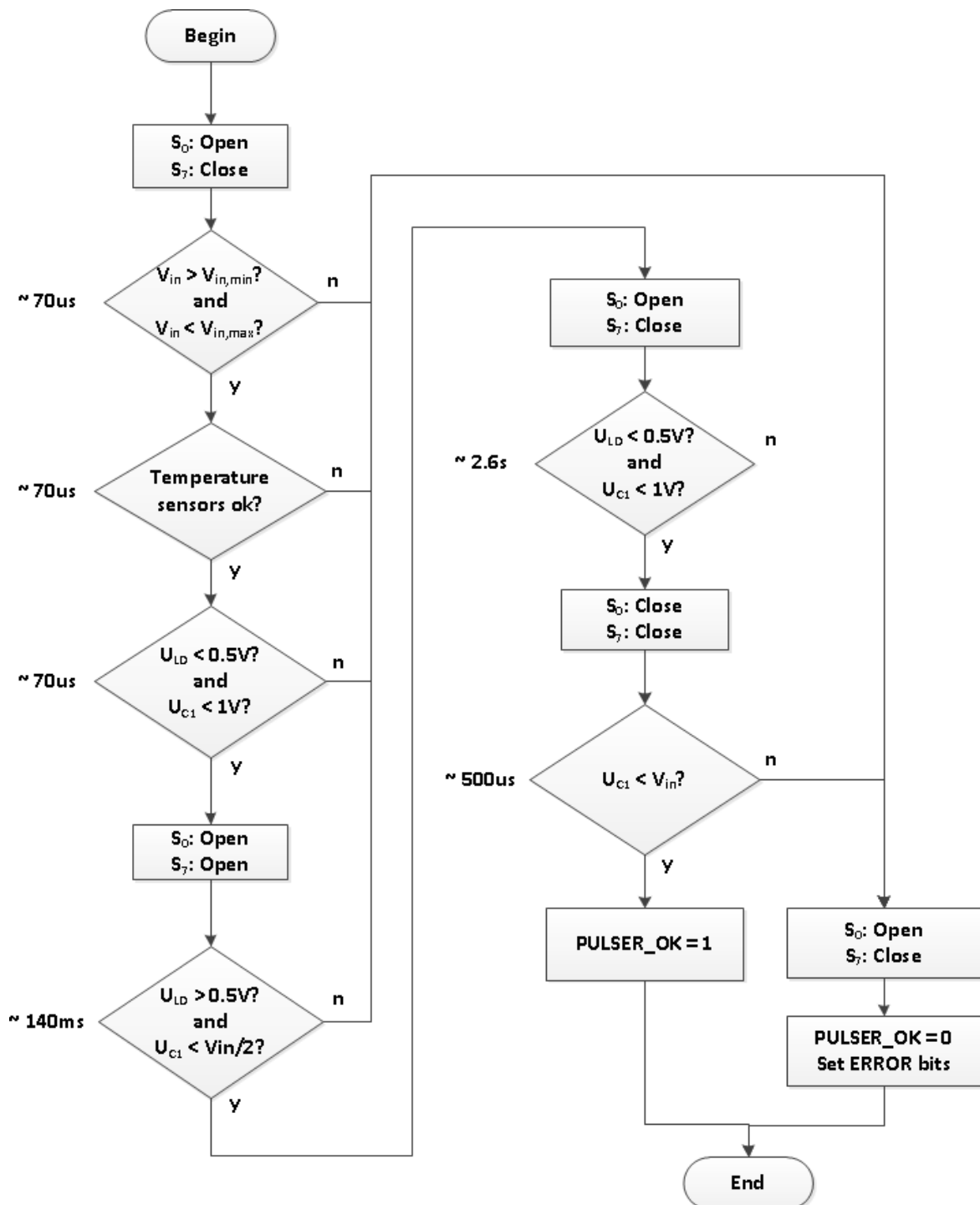

Controlling the driver

The driver can be operated stand alone, with a PLB-21 or by a PC connected to it via USB. It remembers all settings from the last time it was powered on, unless it is configured to load default values on power-on. In latter case it loads pre-configured settings each time the power is toggled – switched off and on again). Connecting a digital control to the driver does not alter the internal settings.

No digital control (factory default)

If no digital control (PLB-21 or USB) is attached, you may use the BOB-Connector to control the driver. If so configured, pin 10 at the BOB connector (“ I_{setpoint} ”) can be used to control the setpoint current. To enable the output pin7 at the BOB connector (“ENABLE”) must be set HIGH.

If an error occurs (e.g. over temperature), the driver will be disabled and the pin 1 of the BOB connector (“PULSER_OK”) is pulled low.

The “enable” pin has to be toggled (set low and high again) in order to enable the driver again.

When using the LDP-C series the ENABLE pin enables the driver but not the current output.

Pin6 of the BOB connector (“PULSE”) directly controls the current output in that case.

The PULSE input does not trigger a soft start. Hence the configured setpoint current applies as fast as possible to the output.

PLB-21

If a PLB-21 is attached to the driver, it can be used to control the behavior of the driver. The PLB-21 may ask for a driver to download. This must be confirmed with “yes” in order for the PLB-21 to work properly. This must always be done when the PLB-21 was connected to any other PicoLAS product. After the download all operating parameters can be accessed using the PLB-21. For a detailed description see chapter PLB-21 below.

USB

If the driver is connected to a PC using an USB cable, all operating parameters can be accessed via a serial RS232 terminal program or the PicoLAS protocol. The PLB-21 is automatically disabled if a USB connection is established. For a detailed description of the serial text protocol and the PicoLAS protocol see below.

Trigger Modes

LDP-CW

The LDP-CW series has no different trigger modes. The PULSE input signal is not used. The output stage as well as the current regulator is controlled by the ENABLE signal and the L_ON bit in the LSTAT register.

Every time the output is enabled the driver performs a soft start and ramps up the output current. Please see the chapters “Soft start” and “Timing Diagram” for more details

LDP-C

The LDP-C series can be configured by the user for internal, external or CW trigger.

CW

When the CW mode is configured the LDP-C behaves like the LDP-CW series. See above for more details.

External

The output stage is controlled by the PULSE signal. Like the CW mode, the current regulator is controlled by the ENABLE signal and L_ON bit, but the output stage is controlled separately. Hence the user can enable the internal current flow, but wait for the soft start to be finished before enabling the output stage. This will lead to a very low rise time compared to the soft start. The actual rise time can be configured using the digital control.

Please see the chapters "Soft start" and "Timing Diagram" for more details

Internal

The output stage is controlled by an internal pulse generator which can be enabled / disabled using the L_ON bit in the LSTAT register. The PULS input is not used. The values for pulse width and repetition rate can be configured via USB or the PLB-21.

Please see the chapters "Soft start" and "Timing Diagram" for more details.



Controlling the driver using a PLB-21

To control the driver with a PLB-21 it must be connected via the enclosed cable. The PLB-21 will not work if the USB and the PLB-21 are connected at the same time. When the PLB-21 is connected the first time to the driver the user is asked to download a new driver. This must be confirmed with "yes" for working the PLB-21 properly.

Menu Structure

The following diagram shows the structure of the PLB-21 menu which affects the driver. All entries are described in detail. All other menu entries are described in the PLB-21 manual. For detailed instructions see the PLB-21 manual.

Menu root

- Pulseparameter
 - o Width
 - o Reprate
 - o Cur(int/ext)
 - o Simmer

- Trigger
 - o Mode
 - o Edge

- Config
 - o Occur(not in HW version 1.2)
 - o Scut
 - o Noload
 - o SStart

- Defaults
 - o Def. pwron
 - o Load defaults
 - o Save defaults

- Temperature
 - o Dev. Off
 - o Temp 1
 - o Temp 2
 - o Temp 3

- Measurement
 - o Uin
 - o Udiod
 - o IDiod

Pulse parameter

In this menu point can be modified the setpoint current and simmer current. See the device specific datasheet for detailed information.

Width

This value defines the width of the pulses generated by the internal pulse generator if the internal trigger is used. It is measured in steps of 0.1us.

Reprate

This value defines the repetition rate of the pulses generated by the internal pulse generator if the internal trigger is used. It is measured in steps of 1 Hz.

Cur (int/ext)

This value defines the setpoint current. It can be switched between internal (int) and external (ext) setpoint by pressing the F1 key.

When using the internal setpoint, the value can be modified by the user.

When using the external setpoint, the value shown is measured value supplied at Pin 10 of the BOB connector. The display is updated every few seconds, so it is not accurate when using analogue modulation.

Simmer

A Simmer current is not available with a LDP-C series when using trigger modes internal or external.

Trigger

The LDP-C supports various trigger modes. These are selected in this Submenu.

Trigger

Possible values are "internal", "external" and "cw". Please note that any change disables the output.

Edge

This value defines the speed of the rising edge. Possible ranges from 0 to 255. The smaller the value is, the smaller is the rise time. It is not used in CW mode.

Config

The LDP-C has some additional safety features which can be user enabled. This is done within this Submenu.

Occur (not in HW version 1.2)

Using the F1 key an additional over current protection can be enabled. If enabled, the LDP-C disables automatically if the output current rises below the given maximum value. The display shows the actual value and it can be modified using the jogdial. If disabled, the display will just read "disabled".

Scut

If enabled, the LDP-C disables automatically if a shortcut on the output clamps during operation is detected. Please note that this feature will not operate properly when the setpoint current is modulated or a compliance voltage below 1 volt is used.

Noload

If enabled, the LDP-C disables automatically if the load has been disconnected during operation. Please note that this feature will not operate properly if the setpoint current is modulated.

SStart

The value shown here is the time span in which the LDP-C raises its output current to the given setpoint when enabled.

Config

The driver can load a default setting each time it powers up or the user commands it to do so. This is done within this Submenu.

Def. pwron

When enabled, the driver loads the saved settings each time it powers up.

Load

When activated via turning the Jogdial or the ENTER key all internal registers are changed to the previously saved values. The output stage has to be re-enabled via the L_ON bit or the FIRE Key afterwards

Save

When activated via turning the Jogdial or the ENTER key all internal registers are stored into an internal EEprom for later usage.

Temperature

The LDP-C 120-20 is equipped with several temperature sensors. In this submenu, the actual and shutdown temperatures can be read and modified. All values are in °C.

Dev. Off

This shows the user defined shutdown temperature. If the LDP-C 120-20 reaches this temperature during operation, the output will be disabled and an error message is displayed. It can be modified within 40...80°C.

Temp 1...3

This shows the actual temperatures measured by the sensors of the LDP-C 120-20.

Measurement

This submenu holds some runtime measurement information.

Uin

This shows the measured value of the supply voltage.

Udiode

This shows the measured value of the compliance voltage of the connected load. The output must be enabled for a correct result. Please note that this is not a real-time measurement. If the Setpoint is modulated, the display may show incorrect values. In that case use the signal of the analogue current monitor at pin 9 on the BOB connector with appropriate measurement equipment.

Idiode

This shows the measured value of the current flow through the connected load.

If an Error Occurs

If an error occurs during operation the pulse output is switched off, the "pulser_ok_ext" signal on the BOB connector is pulled low and a message is displayed on the PLB-21. If no other action is described on the display, a toggle of the ENABLE pin resets the error condition and re-enables the driver.

Controlling the driver via USB

Introduction

In addition to the PLB-21, the driver also has a USB interface to communicate with a computer/laptop. This interface allows communications over a serial text interface as well as using the PicoLAS protocol. While the text interface is designed for communication with a terminal program, the PicoLAS protocol is designed as a system interact protocol.

The switching between the two protocols occurs automatically as soon as the driver receives a certain sequence. The corresponding commands are:

- **PING** for the PicoLAS protocol
- **"init"** followed by <Enter> for the text interface

If the LDP-C 120-20 and the USB interface are both connected at the same time then only the USB interface can be used. As soon as the USB connection is connected to a computer then the LDP-C 120-20 switches automatically over to this.

Description of the USB Interface

The USB connection of the driver emulates a virtual COM port under Windows. The necessary drivers can be downloaded free of charge under <http://www.ftdichip.com/Drivers/VCP.htm>, or they are already included in the current Linux kernels. The virtual COM port created by this can be addressed like a regular one. The connection settings are:

Baud rate	115200
Data bits	8
Stop bits	1
Parity	even

The Serial Text Interface

The following section describes the structure and commands of the text interface.

Structure

Every command that is sent to the driver must be completed with a CR (Enter). It consists of a command word followed by a parameter. If the command was successfully executed a "0" is sent, otherwise a "1". If there is an error pending, the response will be "10", otherwise "11". If the command requires an answer parameter, this parameter is sent before the confirmation is given.

Example:

The user would like to read out the actual setpoint current:

User input: gcurrent<Enter>

Output of the LDP-CW: 12.2<CR><LF>
0<CR><LF>

Example 2:

The user would like to set a new setpoint current:

User input: scurrent 25.7<Enter>

Output of the LDP-CW: 25.7<CR><LF>
0<CR><LF>

Input is done in ASCII code and is case sensitive. Every terminal can be used that supports this standard.

Commands for the LDP-C / CW

The following table contains a command reference for the LDP-CW series. These commands are also implemented in the LDP-C series

Command	Parameter	Answer	Description
scurrent	Current in A	--	Sets the pulse current to the indicated value. A dot is used as decimal point. No more than one decimal place is used! (12.22 is the same as 12.2)
gcurrent	--	Current in A	Outputs the present output current
gcurrentmin	--	Current in A	Outputs the minimum output current
gcurrentmax	--	Current in A	Outputs the maximum output current
gsimmermin	--	Current in A	Outputs the minimum simmer current
gsimmermax	--	Current in A	Outputs the maximum simmer current
ssimmer	Current in A	--	Sets the output current to the indicated value
gsimmer	--	Current in A	Outputs the present simmer current

Command	Parameter	Answer	Description
lon	--	--	Activates the output
loff	--	--	Deactivates the output
slstat	32 bit number	--	Sets the LSTAT register to the value
glstat	--	32 bit number	Outputs the LSTAT register
gerror	--	32 bit number	Outputs the ERROR register
gerrtxt	--	error text	description of every pending error
stempoff	Temperature in °C	--	Changes the shutdown temperature to the passed value
gtempoff	--	Temperature in °C	Outputs the current shutdown temperature
gtempoffmin	--	Temperature in °C	Outputs the minimum shutdown temperature
gtempoffmax	--	Temperature in °C	Outputs the maximum shutdown temperature
curext	--	--	use external current setpoint
curint	--	--	use internal current setpoint
gserial	--	serial number	Returns the device serial number
ps	--	current settings	Prints out an overview of all settings
loaddefault	--	--	loads previously saved settings
savedefault	--	--	saves the current settings as defaults
ghwver	--	hardware version	prints out the hardware version
gswver	--	software version	prints out the software version
gpver	--	parameter version	prints out the parameter version
shortcut	1 / 0	--	1: Enables the shortcut protection 0: Disables the shortcut protection
overcurrent	1 / 0	--	1: Enables the over current protection 0: Disables the over current protection
noload	1 / 0	--	1: Automatically disabled the output if no load is detected (see text for more details) 0: Leave the driver enabled if load fails
ssoftstart	32 bit number	32 bit number	sets the soft start time to the given number multiplied by 166us
gsoftstart	--	32 bit number	returns the current soft start time in steps of 166us



The following table contains all commands for the LDP-C 120-20 series. These are not implemented within the LDP-CW 120-20

Command	Parameter	Answer	Description
spulse	pulse width in us	pulse width in us	Sets the pulse width to the indicated value. A dot is used as decimal point. No more then on decimal place is used!
gpulse	--	pulse width in us	Outputs the present pulse width
gpulsemin	--	pulse width in us	Outputs the minimum pulse width
gpulsemax	--	pulse width in us	Outputs the maximum pulse width
sreprate	repetition rate in Hz	repetition rate in Hz	Sets the repetition rate to the indicated value.
greprate	--	repetition rate in Hz	Outputs the present repetition rate
grepratemin	--	repetition rate in Hz	Outputs the min. repetition rate
grepratemax	--	repetition rate in Hz	Outputs the max. repetition rate
strgmode	0 ... 2	0 ... 2	Sets the trigger mode to the indicated value: 0: external trigger input 1: internal trigger 2: CW mode
gtrgmode	--	0...2	Outputs the current trigger mode
sedge	0 ... 255	0 ... 255	modifies the rise time of the leading edge (smaller is faster)
gedge	--	0 ... 255	Outputs the current rise time

If an Error Occurs

If an error occurs during operation the pulse output is switched off and the return value of a command is no longer "0" or "1" but "10" or "11". Errors have to be acknowledged with a toggle of the ENABLE signal, otherwise switching on again of pulse output is not possible. For more details see the description of the ERROR register.

To retrieve the error, use the **gerror** command for the content of the ERROR register or the **gerrtxt** command for a human readable form.

The PicoLAS Protocol

The following section describes the structure and possible commands of the PicoLAS protocol.

Structure

Each transmission consists of 12 bytes – called a frame as follows – which must be sent consecutively. Otherwise the system times out and the transmission must start again from the beginning.

A frame has a fixed structure. The first two bytes describe the command, the following eight bytes the parameters, followed by one reserved byte and one checksum byte. The checksum is calculated out of the first 11 bytes which are linked by a bitwise XOR.

Thus a frame has the following structure:

Byte	Meaning
1	Bit 8-15 of the command
2	Bit 0-7 of the command
3	Bit 56-63 of the parameter
4	Bit 48-55 of the parameter
5	Bit 40-47 of the parameter
6	Bit 32-39 of the parameter
7	Bit 24-31 of the parameter
8	Bit 16-23 of the parameter
9	Bit 8-15 of the parameter
10	Bit 0-7 of the parameter
11	Reserved, always 0x00
12	Checksum

A properly received frame must be acknowledged by the recipient with an answer, which is also a frame. If the acknowledgement does not occur then the command has not been processed and the sending procedure should be repeated.

If the recipient recognizes the command as valid, but not the parameters, then it will answer with a ILGLPARAM (0xFF12) as command.

In the case that the recipient receives an invalid command it will answer with UNCOM (0xFF13).

If a faulty checksum is recognized then the answer is RXERROR (0xFF10). If this error occurs often then the connection should be checked.

Using the REPEAT (0xFF11) command the recipient can instruct the sender to send the most recent frame again.

General Commands

The following list contains an overview of the general commands which are supported by every product from PicoLAS which makes use of this protocol. The explanation of the individual commands is given further below.

Command Name	Sent Frame		Answer Frame	
	Command	Parameter	Command	Parameter
PING	0xFE01	0	0xFF01	0
IDENT	0xFE02	0	0xFF02	ID
GETHARDVER	0xFE06	0	0xFF06	Version
GETSOFTVER	0xFE07	0	0xFF07	Version
GETSERIAL	0xFE08	0 ... 20	0xFF08	Refer to description
GETIDSTRING	0xFE09	0 ... 20	0xFF09	Refer to description

PING

This command is used to determine the presence of a connected driver and to initialize its interface. It does not change any registers. The command parameter is always 0, the answer parameter too.

IDENT

This command is used to determine the device ID of an attached recipient. It has no effect on the condition of the recipient. The parameter is always 0. The answer contains the ID.

GETHARDVER

Instructs the driver to send back the version number of its hardware. The parameter is always 0. The answer contains the hardware version number. The format of the answer is: 0x000000<major><minor><revision>. In other words, one byte for each of the three elements of the version number.

As example, version 1.2.3 has the parameter 0x000000010203.

GETSOFTVER

Instructs the driver to send back the version number of its firmware. The parameter is always 0. The answer contains the software version of the recipient. The format of the answer is:

0x000000<major><minor><revision>. In other words, one byte for each of the three elements of the version number.

As example, version 2.3.4 has the parameter 0x000000020304.

GETSERIAL

Instructs the driver to send back its serial number. If 0 is sent as parameter, the answer contains the number of (ASCII) digits of the serial number; otherwise the respective position of the serial number is sent in ASCII format.

GETIDSTRING

Instructs the driver to send back its name. If 0 is sent as parameter, the answer contains the number of digits of the string, otherwise the respective position of the serial number is sent in ASCII format.

Commands for the driver

The following table contains a list of the commands which the LDP-CW supports in addition to the generally applicable commands. An explanation of the individual commands and its parameters follows afterwards.

Command	Sent Frame		Received Frame	
	Command	Parameter	Command	Parameter
GETTEMPOFF	0x0001	0	0x0050	64 bit value
GETTEMPACT	0x0002	0	0x0050	64 bit value
SETTEMPOFF	0x0003	40...80 [°C]	0x0050	64 bit value
GETCUR	0x0010	0	0x0051	64 bit value
SETCUR	0x0011	Refer to description	0x0051	64 bit value
GETOCUR	0x0012	0	0x0051	64 bit value
SETOCUR	0x0013	Refer to description	0x0051	64 bit value
GETSIMMER	0x0014	0	0x0059	64 bit value
SETSIMMER	0x0015	Refer to description	0x0059	64 bit value
GETMESSIGNALS	0x0017	0	0x005C	64 bit value
GETLSTAT	0x0020	0	0x0052	32 bit value
GETERROR	0x0021	0	0x0055	32 bit value
GETREGS	0x0022	0	0x0057	64 bit value
SETLSTAT	0x0023	Refer to description	0x0052	32 bit value
SAVEDEFAULTS	0x0027	0	0x005E	0
LOADDEFAULTS	0x0028	0	0x005E	0
GETPREV	0x0029	0	0x005F	32 bit value
GETSOFTSTEP	0x003A	0	0x005B	32 bit value
SETSOFTSTEP	0x003B	Refer to description	0x005B	32 bit value

The following table contains additional commands which apply only to the LDP-C variants:

Command	Sent Frame		Received Frame	
	Command	Parameter	Command	Parameter
GETPULSEWIDTHMINMAX	0x0030	0	0x0053	64 bit value
GETPULSEWIDTH	0x0031	0	0x0053	32 bit value
SETPULSEWIDTH	0x0032	32 bit value	0x0053	32 bit value
GETREPRATEMINMAX	0x0033	0	0x0054	64 bit value
GETREPRATE	0x0034	0	0x0054	32 bit value
SETREPRATE	0x0035	32 bit value	0x0054	32 bit value
GETEDGE	0x0036	0	0x0058	8 bit value
SETEDGE	0x0037	8 bit value	0x0058	8 bit value

Description of the Individual Commands

GETTEMPOFF

The return value contains the average temperature as well as the individual values of all tree temperature sensors. The data format is:

bit	meaning	format
0 ... 15	average temperature [°C]	signed int16
16 ... 30	temperature sensor 1 [°C]	signed int16
31 ... 47	temperature sensor 2 [°C]	signed int16
48 ... 63	temperature sensor 3 [°C]	signed int16

GETTEMPACT

The return value contains the warning and cool down hysteresis values as well as the maximum, minimum and current value of the shutdown temperature. The values for warning and hysteresis are subtracted from the shutdown value to calculate the actual borders. The data format is:

bit	meaning	format
0 ... 7	warning threshold [°C]	signed int8
8 ... 15	hysteresis threshold [°C]	signed int8
16 ... 30	maximum shutdown temperature [°C]	signed int16
31 ... 47	minimum shutdown temperature [°C]	signed int16
48 ... 63	actual shutdown temperature [°C]	signed int16

SETTEMPOFF

This command sets the over temperature shutdown temperature to the given value. The value must be within the borders defined by the minimum and maximum temperature values given by the *GETTEMPACT* command.

The return value contains the same data as in the *GETTEMPOFF* command (see above).

GETCUR

The return value contains the minimum, maximum and actual setpoint value in steps of 0.1A. The data format is:

bit	meaning	format
0 ... 15	maximum current [0.1A]	unsigned int16
16 ... 30	minimum current [0.1A]	unsigned int16
31 ... 47	setpoint current [0.1A]	unsigned int16
48 ... 63	reserved	--

SETCUR

This command sets the current setpoint to the given value in steps of 0.1A. The value must be within the borders defined by the minimum and maximum current values given by the *GETCUR* command. The return value contains the same data as in the *GETCUR* command (see above).

GETOCUR

The return value contains the minimum, maximum and actual over current shutdown value in steps of 0.1A. Please note that this feature must be enabled in the LSTAT register. The data format is:

bit	meaning	format
0 ... 15	maximum current [0.1A]	unsigned int16
16 ... 30	minimum current [0.1A]	unsigned int16
31 ... 47	shutdown current [0.1A]	unsigned int16
48 ... 63	reserved	--

SETOCUR

This command sets the over current shutdown current to the given value in steps of 0.1A. The value must be within the borders defined by the minimum and maximum current values given by the *GETOCUR* command.

The return value contains the same data as in the *GETOCUR* command (see above).

GETSIMMER

The return value contains the minimum, maximum and actual setpoint value of the simmer current in steps of 0.1A. The data format is:

bit	meaning	format
0 ... 15	maximum simmer current [0.1A]	unsigned int16
16 ... 30	minimum simmer current [0.1A]	unsigned int16
31 ... 47	actual simmer current [0.1A]	unsigned int16
48 ... 63	reserved	--

SETSIMMER

This command sets the actual simmer current to the given value in steps of 0.1A. The value must be within the borders defined by the minimum and maximum simmer current values given by the *GETSIMMER* command.

The return value contains the same data as in the *GETSIMMER* command (see above).

GETMESSIGNALS

The return value contains the measurement values of the input voltage, output voltage and output current. The data format is:

bit	meaning	format
0 ... 15	input voltage [0.1V]	unsigned int16
16 ... 30	output voltage [0.1V]	unsigned int16
31 ... 47	output current [0.1A]	unsigned int16
48 ... 63	reserved	--

GETLSTAT

This command returns the value of the LSTAT register. For a complete description of this register see below.

GETERROR

This command returns the value of the ERROR register. For a complete description of this register see below.

GETREGS

This command returns the value of the LSTAT and ERROR register combined in a single 64bit value. The lower 32bit represents the LSTAT register, the upper 32bit the ERROR register.

SETLSTAT

This command sets the LSTAT register to the given value. The return value contains the new register value.

SAVEDEFAULTS

This command saves all settings to an internal EEPROM.

LOADDEFAULTS

This command loads previously saved settings into the driver.

SETPREV

This command returns the version of the current regulator parameters. The data format is:

bit	meaning	format
0 ... 15	revision minor	unsigned int16
16 ... 30	revision major	unsigned int16
31 ... 63	reserved	--

GETSOFTSTEPS

The return value contains the minimum, maximum and actual soft start delay in steps of 166us. The data format is:

bit	meaning	format
0 ... 15	maximum current [166us]	unsigned int16
16 ... 30	minimum current [166us]	unsigned int16
31 ... 47	setpoint current [166us]	unsigned int16
48 ... 63	reserved	--

SETSOFTSTEPS

This command sets the soft start delay to the given value in steps of 166us. The value must be within the borders defined by the minimum and maximum values given by the *GETSOFTSTEPS* command. The return value contains the same data as in the *GETSOFTSTEPS* command (see above).

GETPULSEWIDTHMINMAX

The return value contains the minimum and maximum pulse width of the internal pulse generator combined in a single 64bit value. The data format is:

bit	meaning	format
0 ... 31	minimum width [0.1us]	unsigned int32
32 ... 63	maximum width [0.1us]	unsigned int32

GETPULSEWIDTH

The return value contains the actual pulse width of the internal pulse generator in steps of 0.1us.

SETPULSEWIDTH

This command sets the pulse width of the internal pulse generator to the given value in steps of 0.1A. The value must be within the borders defined by the minimum and maximum values given by the *GETPULSEWIDTHMINMAX* command. The return value is the updated pulse width.

GETREPRATEWIDTHMINMAX

The return value contains the minimum and maximum repetition rate of the internal pulse generator combined in a single 64bit value. The data format is:

bit	meaning	format
0 ... 31	minimum rebrate [Hz]	unsigned int32
32 ... 63	maximum rebrate [Hz]	unsigned int32

GETREPRATE

The return value contains the actual repetition rate of the internal pulse generator in steps of 0.1 us.

SETREPRATE

This command sets the repetition rate of the internal pulse generator to the given value in Hz. The value must be within the borders defined by the minimum and maximum values given by the *GETREPRATEMINMAX* command. The return value is the updated repetition rate.

GETEDGE

The return value contains the actual value of the .

SETEDGE

This command sets .

Register description

Description of the LSTAT Register

The following list contains a description of the individual LSTAT bits. These can be read with GETLSTAT and written with SETLSTAT. With SETLSTAT a complete 32 bit word must always be written. Thus, to change individual bits, first the register must be read out with GETLSTAT, then the desired bits changed and then with SETLSTAT passed again to the LDP-CW.

Bit	Name	Read/Write	Meaning
0	L_ON	Read/write	Switch on/off the pulse output. Note: that this bit is automatically set high every time the driver is powered on.
1-2	TRG_MODE	Read/Write	Trigger mode: 0 : external pulse input 1 : internal pulse generator 2 : CW mode In case of a LDP-CW this is always read 2.
3	ISOLL_EXT	Read/Write	When "1" the external setpoint current is used
4	INIT_COMPLETE	Read	The power-on test is performed successfully
5	PULSER_OK	Read	Indicates that the driver is in no error condition
6	ENABLE_OK	Read	Indicates that the external enable is given
7	SHORTCUT_CHECK	Read/Write	When "1" the driver will check for an shortcut on the output clamps during operation
8	NOLOAD_CHECK	Read/Write	When "1" the driver will check for open output clamps during operation
9	OVERCURRENT_CHECK	Read/Write	When "1" the driver will check for an over current on the connected load during operation
10	CW_ONLY	Read	Indicates that only CW operation is possible (TRG_MODE 2)
11	MEN	Read	Indicates that the MEN is given
12	DEFAULT_ON_PWRON	Read/Write	When "1" the driver will load the default values at each power-up.
13-31	Reserved	Read	Reserved

Description of the ERROR Register

The following list contains a description of the individual bits of the ERROR register. A “1” as a bit leads to a deactivation of the drivers output. Bit 3 is excluded of this directive as it is just a warning. The Bits 1...6 and 10...12 are cleared every time the ENABLE pin is set low.

All other bits are cleared by toggling the main power. If any self test related error condition persists, a hardware failure is possible.

The bit 20 indicates that the ENABLE pin was set high during power on. It must remain low until the pulser_ok_ext signal or the related bit in the LSTAT register is set high.

The bit 21 indicates that the MEN pin was set low during power on. Is must set high during power on. Otherwise the self test will fail.

Bit	Name	R / W	Meaning
0	TEMP_SENSOR_FAIL	Read	One or more temperature sensors failed.
1	TEMP_OVERSTEPPED	Read	Maximum temperature overstepped
2	TEMP_HYSTERESIS	Read	Device is cooling down. Temperature needs to drop below (maximum – 10°)
3	TEMP_WARN	Read	Device temperature 5° before shutdown
4	LOAD_SHORT	Read	Shortcut on the output clamps detected
5	LOAD_NONE	Read	No connected load detected
6	OVERCURRENT	Read	Maximum current overstepped
7	PHASE_UNCAL	Read	Device is not properly calibrated. Please contact your distributor
8	SHUT_UNCAL	Read	Device is not properly calibrated. Please contact your distributor
9	I2C_FAIL	Read	Internal communication error. Please contact your distributor
10	VCC_LOW	Read	Supply voltage below minimum
11	VCC_HIGH	Read	Supply voltage above maximum
12	VCC_DROP	Read	Supply voltage drops during operation
13	CROWBAR_ALWAYS_OPEN	Read	Indicates a defect crowbar. Please contact your distributor
14	CROWBAR_ALWAYS_CLOSE	Read	Indicates a defect crowbar. Please contact your distributor
15	HST_ALWAYS_OPEN	Read	Indicates a defect safety switch. Please contact your distributor
16	HST_ALWAYS_CLOSE	Read	Indicates a defect safety switch. Please contact your distributor
17	Reserved	Read	Reserved
18	CFG_CHKSUM_FAIL	Read	Indicates an incorrect configuration. Please contact your distributor
19	AUTO_I_OFFSET_FAIL	Read	Indicates an internal error. Please contact your distributor
20	ENABLE_DURING_POWERUP_ENABLED	Read	Enable was high during power-on
21	MEN_DURING_POWERUP_DISABLED	Read	MEN was low during power-on
22	POST_FAILED	Read	Self test failed
23-31	Reserved	Read	Reserved