

FOCUS[®]

LED-SPOT 200

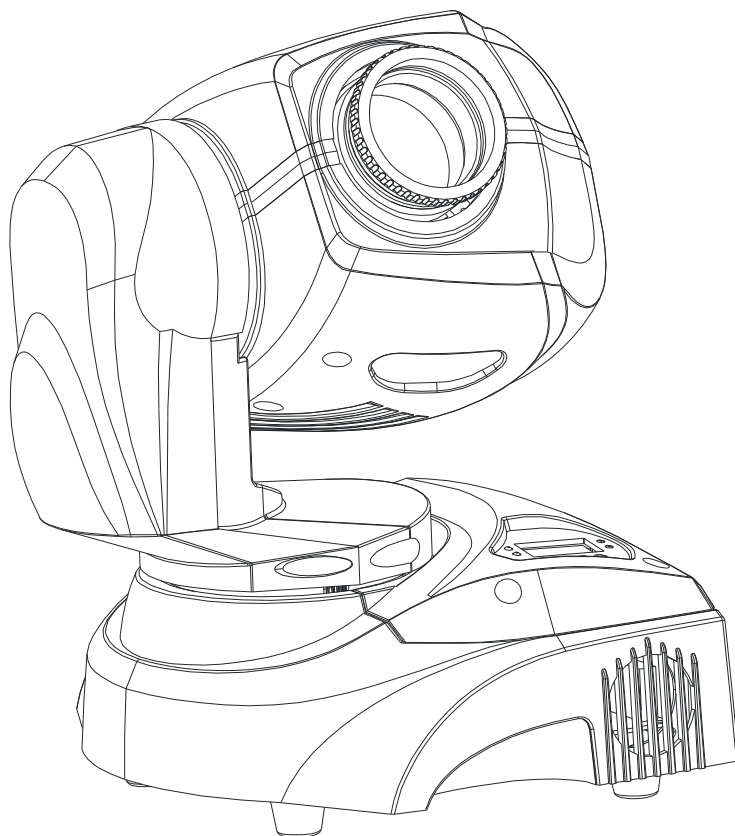

USER MANUAL

Please read the instruction carefully before use

CONTENTS

1. Safety Instructions.....	2
2. Technical Specifications	3
3. How To Control The Unit	4
3.1 Control Panel	4
3.2 Main Function	5
3.3 Home Position Adjust	10
4. How To Control The Unit	10
4.1 Master/Slave Built In Preprogrammed Function	11
4.2 Easy Controller	11
4.3 DMX Controller.....	12
4.4 DMX 512 Configuration	13
4.5 DMX512 Connection	14
5. Troubleshooting	15
6. Cleaning and Maintenance	16

1. Safety Instructions



Please read the instructions carefully which includes important information about the installation, operation and maintenance.

WARNING

- Please keep this User Guide for future consultation. If you sell the unit to another user, be sure that they also receive this instruction booklet.
- Unpack and check carefully there is no transportation damage before using the unit.
- Before operating, ensure that the voltage and frequency of power supply match the power requirements of the unit.
- It's important to ground the yellow/green conductor to earth in order to avoid electric shock.
- The unit is for indoor use only. Use only in a dry location.
- The unit must be installed in a location with adequate ventilation, at least 50cm from adjacent surfaces. Be sure that no ventilation slots are blocked.
- Disconnect main power before replacement or servicing.
- Make sure there are no flammable materials close to the unit while operating as it is fire hazard.
- Use safety cable when fixes this unit. Don't handle the unit by taking its head only, but always by taking its base.
- Maximum ambient temperature is T_a : 40°C. Don't operate it where the temperature is higher than this.
- Unit surface temperature may reach up to 85°C. Don't touch the housing bare-hand during its operation. Turn off the power and allow about 15 minutes for the unit to cool down before replacing or serving.
- In the event of serious operating problem, stop using the unit immediately. Never try to repair the unit by yourself. Repairs carried out by unskilled people can lead to damage or malfunction. Please contact the nearest authorized technical assistance center. Always use the same type spare parts.
- Do not touch any wire during operation as high voltage might be causing electric shock.

Warning

- To prevent or reduce the risk of electrical shock or fire, do not expose the unit to rain or

moisture.

- Do not open the unit within five minutes after switching off.
- The housing, the lenses, or the ultraviolet filter must be replaced if they are visibly damaged.

Caution

There are no user serviceable parts inside the unit. Do not open the housing or attempt any repairs yourself. In the unlikely event your unit may require service, please contact your nearest dealer.

Installation

The unit should be mounted via its screw holes on the bracket. Always ensure that the unit is firmly fixed to avoid vibration and slipping while operating. And make sure that the structure to which you are attaching the unit is secure and is able to support a weight of 10 times of the unit's weight. Also always use a safety cable that can hold 12 times of the weight of the unit when installing the fixture.

The equipment must be fixed by professionals. And it must be fixed at a place where is out of the touch of people and has no one pass by or under it

2. Technical Specifications

The unit is DMX 512 fixture. It features full DMX 512 control. It can be also linked together in master/slave connection, as many as required and run by built-in program chase sequences automatically or by sound activation through an internal microphone to create an intelligent effect.

- It can be operated by DMX 512 control or can be used as an individual unit without a controller.
- Features different preprogrammed chase patterns.
- Please use a cable when connecting units together.
- Accurate focusable optics system and ultra smooth stepping motors, Fan cooled.
- Pan: 540 deg. Tilt: 270 deg.
- Power Voltage : AC 230V~50Hz
- Power Consumption: 60W
- Light source: 1×25W LED

• Dimension: 248x 228 x 329mm

• Weight: 5.1 kg

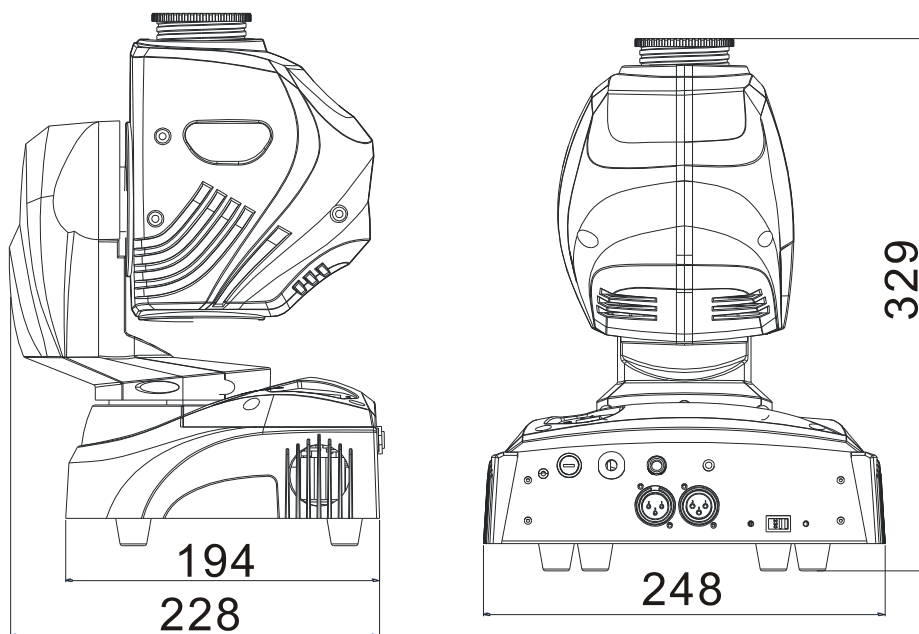

3. How To Control The Unit

3.1 Control Panel

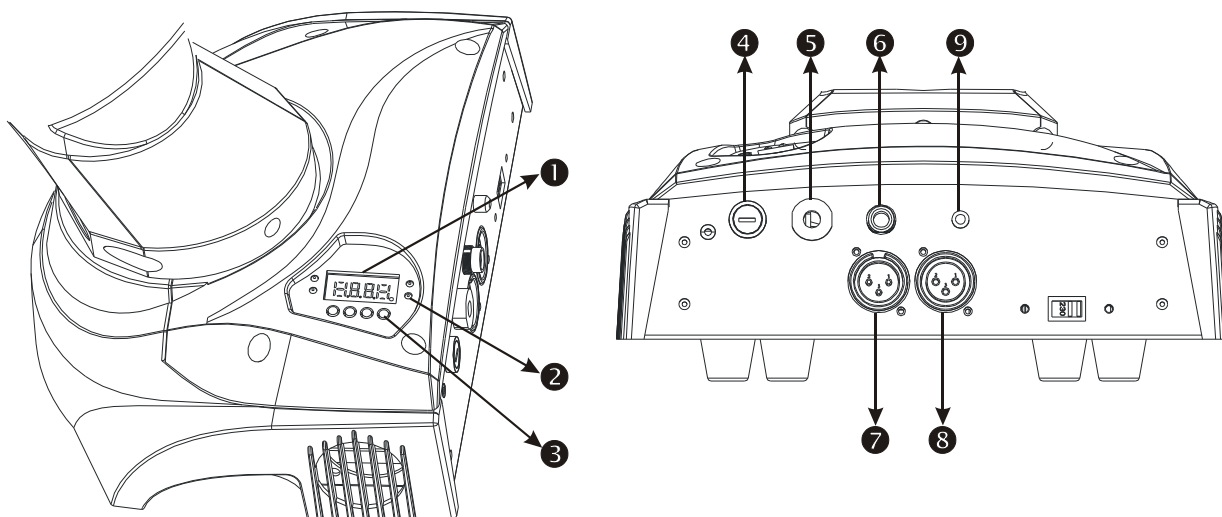

o,1 **Display:**

To show the various menus and the selected functions

o,2 **LED:**

DMX	On	DMX input present
MASTER	On	Master Mode
SLAVE	On	Slave Mode
SOUND	On	Sound Mode

o,3 **Button:**

MENU	To select the programming functions
DOWN	To go backward in the selected functions
UP	To go forward in the selected functions
ENTER	To confirm the selected functions

o,4 **Fuse (T 2A):**

Protect the unit from damage of over current

o,5 **Mains input:**

Connect to the power supply

o,6 **Only for remote control:**

Connecting whit CA-8 to control the unit for Stand by, Function and Mode function

o,7 **DMX input:**

For DMX512 link, use 5-pin XLR plug cable to input DMX signal

o,8 **DMX output:**

For DMX512 link, use 5-pin XLR plugs cable to link the next unit

o,9 **Sensitivity:**

Adjust the sensitivity

3.2 Main Function

To select any of the given functions, press the **MENU** button up to when the required one is showing on the display. Select the function by **ENTER** button and the display will blink. Use **DOWN** and **UP** button to change the mode. Once the required mode has been selected, press the **ENTER**

button to setup or it will automatically return to the main functions without any change after idling 8 seconds. To go back to the functions without any change press the **MENU** button. The main functions are showing below:

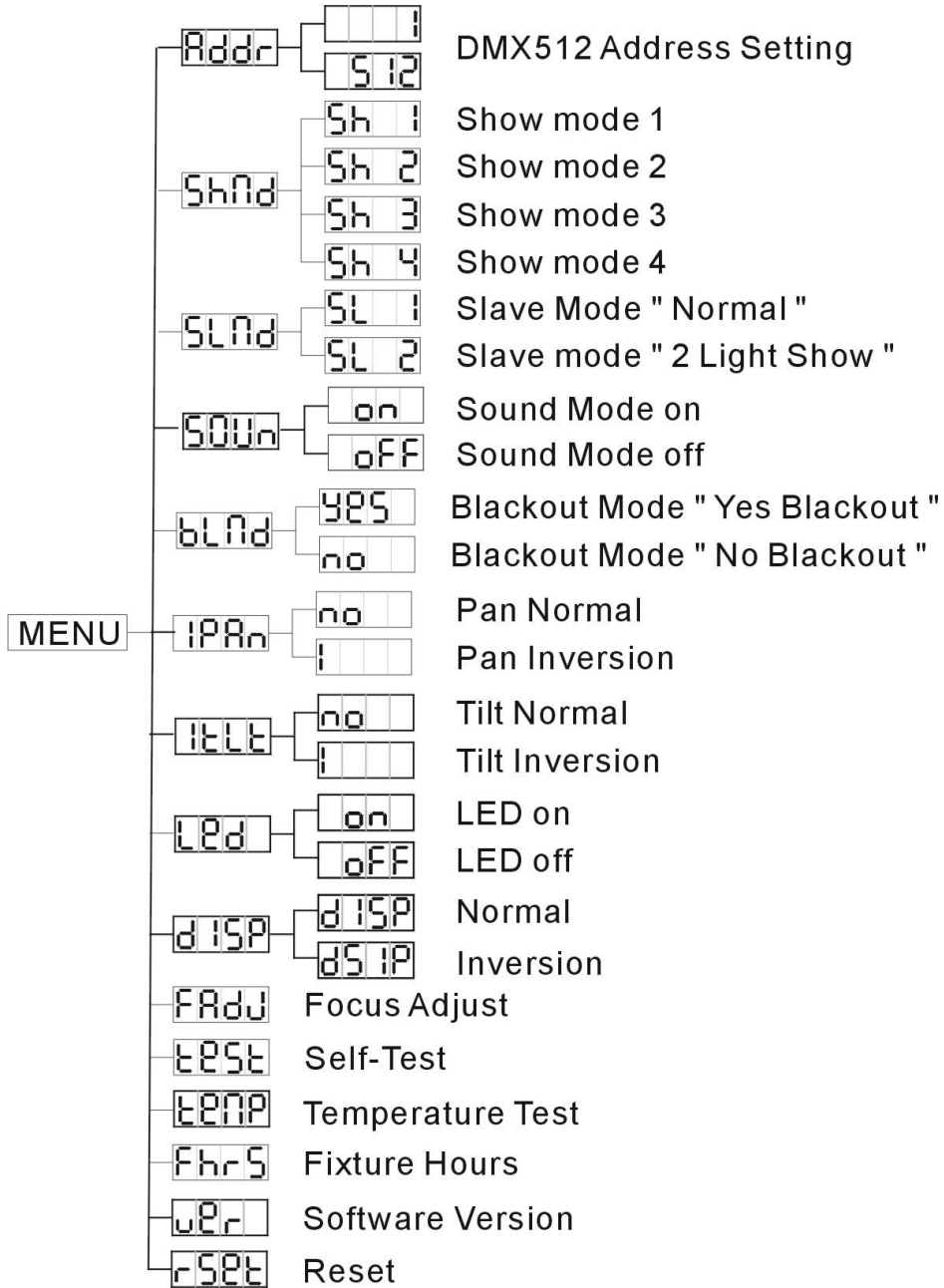

Addr DMX 512 Address Setting

Press the **MENU** button up to when the **Addr** is showing on the display. Pressing **ENTER** button and the display will blink. Use **DOWN** and **UP** button to change the DMX512 address. Once the address has been selected, press the **ENTER** button to setup or automatically return to the main functions without any change after 8 seconds. To go back to the functions without any change press the **MENU** button again.

Shnd Show Mode

Press the **MENU** button up to when the **Shnd** is showing on the display. Pressing **ENTER** button and the display will blink. Use **DOWN** and **UP** button to select the **Sh 1** (show 1) or **Sh 2** (show 2) or **Sh 3** (show 3) or **Sh 4** (show 4) mode. Once the mode has been selected, press the **ENTER** button to setup or automatically return to the main functions without any change after 8 seconds. To go back to the functions without any change press the **MENU** button again.

Sh 1 Show 1 mode - Fixture is placed on the floor. Tilt movement angle 210°.

Sh 2 Show 2 mode - Fixture is fixed under ceiling. Tilt movement angle 90°.

Sh 3 Show 3 mode - Fixture is placed on the speaker, the spot is always projecting to the audience's direction; i.e. in front of the stage. Pan movement angel (left to right to left): 160°. Tilt movement angel: 90° (60° above horizon; 30° below horizon.)

Sh 4 Show 4 mode - Fixture is fixed under ceiling. The spot is mainly projecting in front of the stage. Pan movement angel (left to right to left):160°. Tilt movement angel: 90° (vertically, front 75°; back 15°)

SLnd Slave Mode

Press the **MENU** button up to when the **SLnd** is showing on the display. Pressing **ENTER** button and the display will blink. Use **DOWN** and **UP** button to select the **SL 1** (normal) or **SL 2** (2 light show) mode. Once the mode has been selected, press the **ENTER** button to setup or automatically return to the main functions without any change after 8 seconds. To go back to the functions without any change press the **MENU** button again.

SOUN Sound Mode

Press the **MENU** button until the **SOUN** is showing on the display. Pressing **ENTER** button and the display will blink. Use **DOWN** and **UP** button to select the **on** (sound on) or **OFF** (sound off) mode. Once the mode has been selected, press the **ENTER** button to setup or automatically return to the main functions without any change after 8 seconds. To go back to the functions without any change press the **MENU** button again.

BLND Blackout Mode

Press the **MENU** button up to when the **BLND** is showing on the display. Pressing **ENTER** button and the display will blink. Use **DOWN** and **UP** button to select the **YES** (yes blackout) or **no** (no blackout) mode. Once the mode has been selected, press the **ENTER** button to setup or automatically return to the main functions without any change after 8 seconds. To go back to the functions without any change press the **MENU** button again.

IPAN Pan Inversion

Press the **MENU** button up to when the **IPAN** is showing on the display. Pressing **ENTER** button and the display will blink. Use **DOWN** and **UP** button to select the **no** (normal) or **i** (pan inversion) mode. Once the mode has been selected, press the **ENTER** button to setup or automatically return to the main functions without any change after 8 seconds. To go back to the functions without any change press the **MENU** button again.

TILT Tilt Inversion

Press the **MENU** button up to when the **TILT** is showing on the display. Pressing **ENTER** button and the display will blink. Use **DOWN** and **UP** button to select the **no** (normal) or **i** (tilt inversion) mode. Once the mode has been selected, press the **ENTER** button to setup or automatically return to the main functions without any change after 8 seconds. To go back to the functions without any change press the **MENU** button again.

LEd Led Display

Press the **MENU** button up to when the **LEd** is showing on the display. Pressing **ENTER** button and the display will blink. Use **DOWN** and **UP** button to select the **on** (Led on) or **off** (Led off) mode. Once the mode has been selected, press the **ENTER** button to setup or automatically return to the main functions without any change after 8 seconds. To go back to the functions without any change press the **MENU** button again.

dISP Display Inversion

It is good for you to install the unit on the floor or under ceiling. Press the **MENU** button up to when the **dISP** is blinking on the display. Use the **ENTER** button to change to the mode **dISP** (display normal), It will automatically store after 8 seconds. Or press the **ENTER** button again return to the mode **dSPiP** (display inversion). To go back to the functions press the **MENU** button.

dISP Display normal mode for the fixture putting on the floor.

dSPiP Display inversion mode for the fixture fixing under ceiling.

FAdJ Focus Adjust

Press the **MENU** button up to when the **FAdJ** is blinking on the display. Pressing **ENTER** button to change orientation of the light, then you can turn the plastic lens manually to adjust the focus of the unit. To go back to the functions press the **MENU** button again.

tEst Self-Test

Press the **MENU** button up to when the **tEst** is blinking on the display. Pressing **ENTER** button and the unit will run self-test by built-in program. To go back to the functions press the **MENU** button again.

tEMP Temperature Test

Press the **MENU** button up to when the **tEMP** is blinking on the display. Pressing **ENTER** button

and the display will show the temperature of the unit. To go back to the functions press the **MENU** button again.

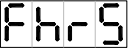
 Fixture Hours

Press the **MENU** button up to when the  is blinking on the display. Pressing **ENTER** button and the display will show the number of working hours of the unit. To go back to the functions press the **MENU** button again.

 Software version

Press the **MENU** button up to when the  is blinking on the display. Pressing **ENTER** button and the display will show the version of software of the unit. To go back to the functions press the **MENU** button again.

 Reset

Press the **MENU** button up to when the  is blinking on the display. Pressing **ENTER** button and all channels of the unit will return to their standard position. To go back to the functions without any change press the **MENU** button again.

3.3 Home Position Adjust

In the main functions, hold **Enter** button for at least 3 seconds into offset mode, when the  is shown on the display. Pressing **ENTER** button and the display will blink. Use **DOWN** and **UP** button to adjust the home position. Once the position has been selected, press the **ENTER** button to setup, hold the **MENU** button for about 3 seconds or wait for 8 seconds to back to the main functions without any change.

4. How To Control The Unit

You can operate the unit in three ways:

1. By master/slave built-in preprogram function
2. By easy controller

3. By universal DMX controller

No need to turn the unit off when you change the DMX address, as new DMX address setting will be affected at once. Every time you turn the unit on, it will show **0525** on the display and move all the motors to their 'home' position and you may hear some noises for about 20 seconds. After that the unit will be ready to receive DMX signal or run the built in programs.

4.1 Master/Slave Built In Preprogrammed Function

By linking the units in master/slave connection, the first unit will control the other units to give an automatic, sound activated, synchronized light show. This function is good when you want an instant show. You have to set the first unit in master mode **Sh0d** and select **Sh01** (show 1) or **Sh02** (show 2) or **Sh03** (show 3) or **Sh04** (show 4) mode. Its DMX input jack will have nothing plugged into it, and Its master LED will be constantly on and sound LED will flash to the music. The other units will have to set in slave mode **SL0d** and select **SL01** (normal) or **SL02** (2 light show) mode, Their DMX cables plugged into the DMX input jacks (daisy chain) and the slave led lights will constantly on.

2-light show

In **SL0d** (slave mode), **SL01** means the unit works normally and **SL02** means 2-light show. In order to create a great light show, you can set **SL02** on the second unit to get contrast movement to each other, even if you have two units only.

4.2 Easy Controller

The easy remote control is used only in master/slave mode. By connecting to the 1/4" microphone jack of the first unit, you will find that the remote control on the first unit will control all the other units functions press the MENU button again.

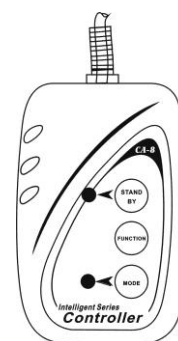

Stand By	Blackout the unit		
Function	1. Sync. Strobe 2. Async strobe 3. Sound Strobe	Show 1-4	1. Press to select color 2. Hold to select gobo
Mode	Sound (LED OFF)	Show (LED Slow Blinking)	LED ON











































4.3 DMX Controller

A universal DMX controller to control the units, you have to set DMX address from 1 to 512 channel so that the units can receive DMX signal.

Press the **MENU** button up to when the **Addr** is showing on the display. Pressing **ENTER** button and the display will blink. Use **DOWN** and **UP** button to change the DMX512 address. Once the address has been selected, press and keep **ENTER** button pressed up to when the display stops blinking or storing automatically 8 seconds later. To go back to the functions without any change press the **MENU** button again. If you use please refer to the following diagram to address your DMX512 channel for the first 4 units:



4.4 DMX 512 Configuration

DMX512 Configuration					
Ch1	Ch2	Ch3	Ch4	Ch5	Ch6
Pan	Tilt	Strobe	Gobo	Color	Dimmer
 540°	 270°	248-255 Open 240-247 Random Strobe 232-239 Open 190-231 Fast open slow close 182-189 Open 140-181 Slow open fast close 132-139 Open ⚡ 16-131 ⚡ ⚡ 8-15 Open 0-7 Blackout	255 Rotation Fast  128 Rotation Slow 122-127   115-121   108-114   101-107   093-100   086-092   079-085   072-078   064-071   058-063   051-057   044-050   037-043   029-036   022-028   015-021   008-014   000-007  	255 Rotation Fast  128 Rotation Slow  120-127 Blue 105-119 Yellow 090-104 Green 075-089 Light Blue 060-074 Orange 045-059 Pink 030-044 Light Yellow 015-029 Light Green 000-014 White	 255 100% 0 0%

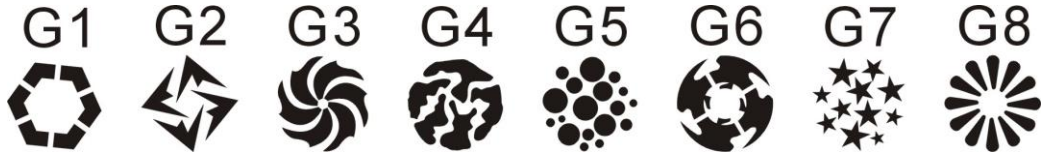

4.5 DMX512 Connection

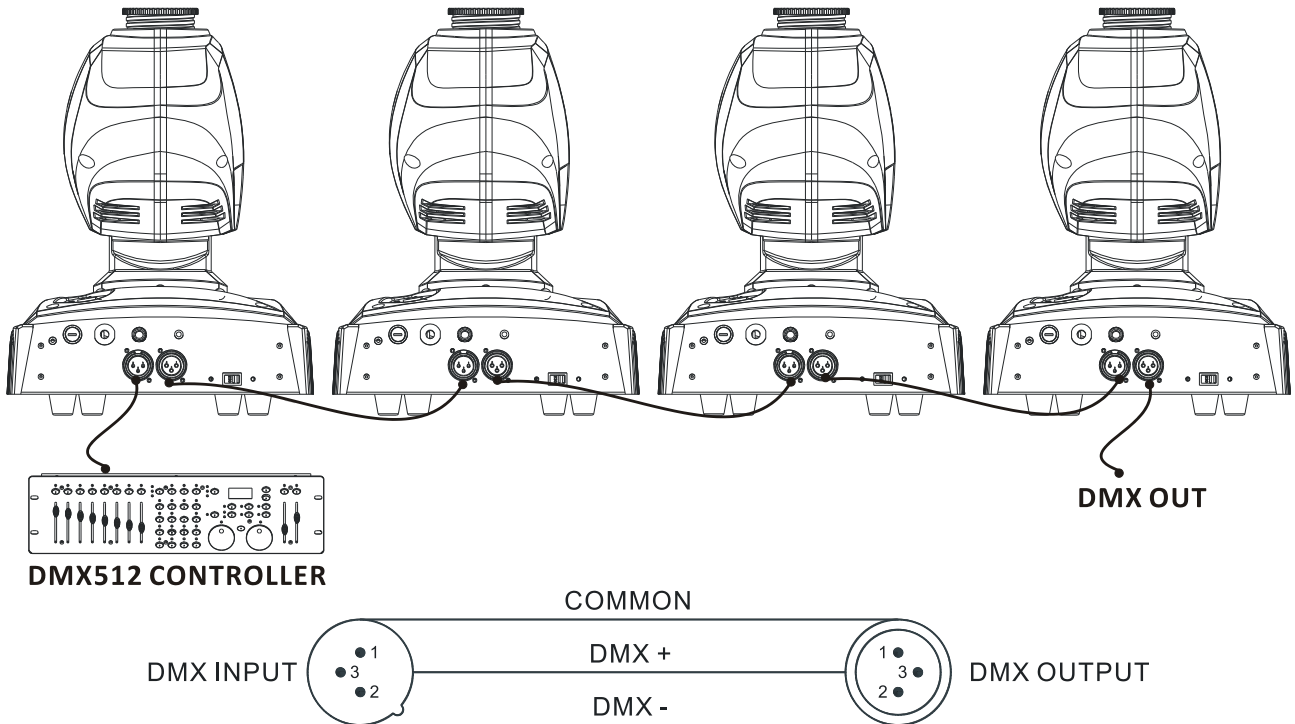

Termination reduces signal errors and to avoid signal transmission problems and interference. It is always advisable to connect a DMX terminal. (Resistance 120 ohm 1/4W) between pin2(DMX-) and pin3(DMX+) of the last fixture.

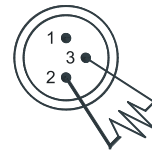

1. If you using a controller with 5 pins DMX output, you need to use a 5 to 3 pin adapter-cable.
2. At last unit, the DMX cable has to be terminated with a terminator. Solder a 120 ohm 1/4W resistor between pin 2(DMX-) and pin 3(DMX+) into a 3-pin XLR-plug and plug it in the DMX-output of the last unit.
3. Connect the unit together in a `daisy chain` by XLR plug from the output of the unit to the input of the next unit. The cable can not branched or split to a `Y` cable. DMX 512 is a very high-speed signal. Inadequate or damaged cables, soldered joints or corroded connectors can easily distort the signal and shut down the system.
4. The DMX output and input connectors are pass-through to maintain the DMX circuit, when one of the units' power is disconnected.
5. Each lighting unit needs to have an address set to receive the data sent by the controller. The address number is between 0-511 (usually 0 & 1 are equal to 1).

6. The end of the DMX 512 system should be terminated to reduce signal errors.
7. 3 pin XLR connectors are more popular than 5 pin XLR.
3 pin XLR: Pin 1: GND, Pin 2: Negative signal (-), Pin 3: Positive signal (+)
5 pin XLR: Pin 1: GND, Pin 2: Negative signal (-), Pin 3: Positive signal (+), Pin 4/Pin 5: Not used.

5. Troubleshooting

Following are a few common problems that may occur during operation. Here are some suggestions for easy troubleshooting:

A. The fixture does not work, no light

1. Check the connection of power and main fuse.
2. Measure the mains voltage on the main connector.

B. Not responding to DMX controller

1. DMX LED should be on. If not, check DMX connectors, cables to see if link properly.
2. If the DMX LED is on and no response to the channel, check the address settings and DMX polarity.
3. If you have intermittent DMX signal problems, check the pins on connectors or on PCB of the fixture or the previous one.
4. Try to use another DMX controller.
5. Check if the DMX cables run near or run alongside to high voltage cables that may cause damage or interference to DMX interface circuit.

C. Some fixtures don't respond to the easy controller

1. Check the LED for the response of the master/ slave mode signal.
2. Check if the unit is receiving DMX signal and cut it off.

D. No response to the sound

1. Make sure the fixture does not receive DMX signal.
2. Check microphone to see if it is good by tapping the microphone.

E. One of the channels is not working well

1. The stepper motor might be damaged or the cable connected to the PCB is broken.
2. The motor's drive IC on the PCB might be out of condition.

6. Cleaning and Maintenance

The cleaning must be carried out periodically to optimize light output. Cleaning frequency depends on the environment in which the fixture operates: moist, smoky or particularly dirty surrounding can cause greater accumulation of dirt on the fixture.

- Clean with lint-free cloth using normal glass cleaning liquid.
- Clean the surface at least every 30 days.
- Never use alcohol or solvents.

Declaration of Conformity

We declare that our products (lighting equipments) comply with the following specification and bears CE mark in accordance with the provision of the Electromagnetic Compatibility (EMC) Directive 2004/108/EC.

EN55103-1: 2009 ; EN55103-2: 2009;
EN61000-3-2: 2006 + A1:2009 + A2:2009; EN61000-3-3: 2008.

&

Harmonized Standard

EN 60598-1:2008 + All:2009; EN 60598-2-17:1989 + A2:1991;
EN 62471:2008; EN 62493: 2010
Safety of household and similar electrical appliances
Part 1: General requirements

Innovation, Quality, Performance