

Campagnolo®



ULTRA-TORQUE
CRANKSET
USER'S MANUAL

CONTENTS

1	GENERAL NOTES AND COMPATIBILITY	21
2	INFORMATION AND TECHNICAL SUPPORT	23
3	SAFETY RECOMMENDATIONS	26
4	BEFORE USING YOUR BICYCLE	27
5	USE	29
6	PERIODIC INSPECTIONS	31
7	MAINTENANCE/LUBRICATION/CLEANING	32
8	PERIODIC MAINTENANCE TABLE	34

1 - GENERAL NOTES AND COMPATIBILITY

**WARNING!**

Carefully read, follow and understand the instructions given in this manual. It is an essential part of the product, and you should keep it in a safe place for future reference.

MECHANIC QUALIFICATION - Please be advised that many bicycle service and repair tasks require specialized knowledge, tools and experience. General mechanical aptitude may not be sufficient to properly service or repair your bicycle. If you have any doubt whatsoever regarding your service/repair ability, please take your bicycle to a qualified repair shop.

"AN ACCIDENT" - Please note that throughout this manual, reference is made that "an accident" could occur. Any accident could result in damage to your bicycle, its components and, more importantly, could cause you or a bystander to sustain severe personal injury or even death.

INTENDED USE - This Campagnolo® product is designed and manufactured for use only on road racing style bicycles that are ridden only on smooth road or track surfaces. Any other use of this product, such as off-road or on trails is forbidden.

LIFESPAN - WEAR - INSPECTION REQUIREMENT - The lifespan of Campagnolo® components depends on many factors, such as rider size and riding conditions. Impacts, falls, improper use or harsh use in general may compromise the structural integrity of the components and significantly reduce their lifespan. Some components are also subject to wear over time. Please have your bicycle regularly inspected by a qualified mechanic for any cracks, deformation, signs of fatigue or wear (use of penetrating fluid or other visual enhancers to locate cracks on parts is recommended).

If the inspection reveals any deformation, cracks, impact marks or stress marks, no matter how slight, immediately replace the component; components that have experienced excessive wear also need immediate replacement. The frequency of inspection depends on many factors; check with your authorized Campagnolo® representative to select a schedule that is best for you.

If you weigh 82 kg/180 lbs or more, you must be especially vigilant and have your bicycle inspected more frequently (than someone weighting less than 82 kg/180 lbs) for any evidence of cracks, deformation, or other signs of fatigue or stress. Check with your mechanic to discuss whether the components you selected are suitable for your use, and to determine the frequency of inspections.

The components of Campagnolo® 11s transmissions, as well as the brakes, rims, pedals and all other Campagnolo® products are designed as a single integrated system. Not to affect safety, performance, longevity, functionality and the WARRANTY, use exclusively the parts and components supplied or specified by Campagnolo S.r.l., without interfacing or replacing them with products, parts or components manufactured by other companies.

The user of this Campagnolo® product expressly recognizes that there are risks inherent in bicycle riding, including but not limited to the risk that a component of the bicycle can fail, resulting in an accident, personal injury or death. By his purchase and use of this Campagnolo® product, the user expressly, voluntarily and knowingly accepts and/or assumes these risks, including but not limited to the risk of passive or active negligence of Campagnolo s.r.l. or hidden, latent or obvious defects in the product, and agrees to hold Campagnolo s.r.l. harmless to the fullest extent permitted by law against any resulting damages.

2 - INFORMATION AND TECHNICAL SUPPORT



Refer to the diagram on the following page when performing installation or adjustments or if you have a technical problem. Scan this QR CODE to access the search page to find your closest Campagnolo Pro Shop, or go to www.campagnolo.com.



Scan this QR CODE to access more detailed information and frequently asked questions at www.campagnolo.com

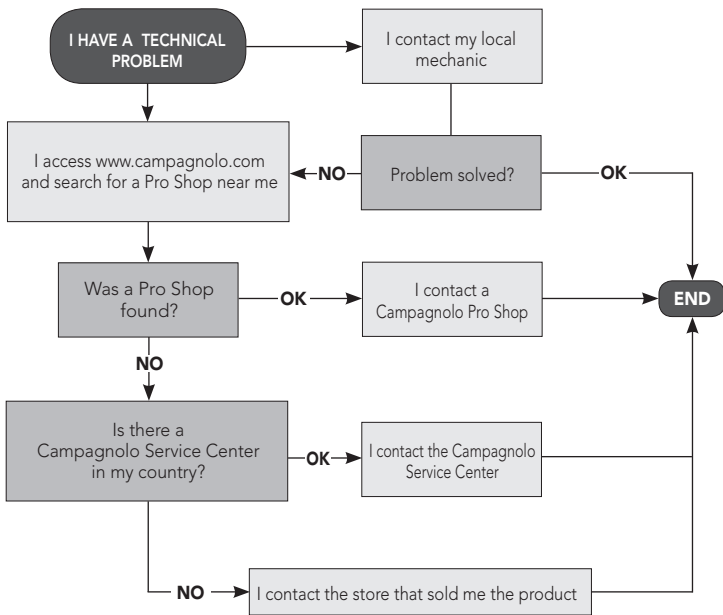

NOTE FOR SPECIALISED MECHANICS: Please remember that all assembly, disassembly, adjustment and maintenance procedures for the EPS drivetrain are described in the EPS technical manual, which is available in PDF format on our internet site www.campagnolo.com. Scan this QR CODE to directly access the main page

IMPORTANT

Always check the tables in the product technical manual to ensure compatibility with the previous Campagnolo ranges.

Note: Tools supplied by other manufacturers for components similar to Campagnolo® components, may not be compatible with Campagnolo® components. Likewise, tools supplied by Campagnolo s.r.l. may not be compatible with components supplied by other manufacturers. Always check with your mechanic or the tool manufacturer to insure compatibility before using tools supplied by one manufacturer on components supplied by another.

3 - SAFETY RECOMMENDATIONS

- Please be advised that if the maintenance and repair procedures provided in this manual are not properly performed, or if the other instructions in this manual are not followed, an accident could occur.
- Never make any modifications whatsoever to any component of any Campagnolo® product.
- Parts which have been bent or otherwise damaged in an accident or as a result of any other impact must not be re-straightened. They must be replaced immediately with original Campagnolo® parts.
- Wear clothes which are snug-fitting and which make you visible to traffic, such as neon fluorescent or other bright colors.
- Avoid biking at night because it is more difficult for you to be seen by traffic, and it is more difficult for you to see obstructions on the ground. If you do ride at night, you should equip your bicycle with and use a headlight and a tail light.
- Never use a bicycle or bicycle component unless you are thoroughly familiar with its use and maintenance history. "Used" equipment may have been misused and abused, and can unexpectedly fail resulting in an accident.
- When riding in wet conditions, remember that the stopping power of your brakes is greatly reduced and that the adherence of the tires on the ground is considerably reduced. This makes it harder to control and stop your bicycle. Extra care is required when riding your bicycle in wet conditions to avoid an accident.
- Always wear a properly fitted and fastened bicycle helmet that has been approved by ANSI or SNELL.

4 - BEFORE USING YOUR BICYCLE

DO NOT RIDE YOUR BICYCLE IF IT DOES NOT PASS THIS PRE-RIDE TEST CORRECT ANY CONDITION BEFORE YOUR RIDE.

- Be sure that all of the components of your bicycle, including but not limited to your brakes, pedals, handgrips, handlebars, frame and seating system, are in optimum condition and suitable for use.
- Be sure that none of the components of bicycle are bent, damaged or out of alignment.
- Check to be sure that all quick release fasteners, nuts and bolts are properly adjusted. Bounce the bicycle on the ground and listen and look for anything which may be loose.
- Be sure that your wheels are perfectly centred. Spin the wheels to be sure that they do not wobble up and down or from side to side, and that they do not make contact with the fork legs or brake pads while rotating.
- Check all reflectors to make sure that they are clean, straight and securely mounted.
- Check you brake pads and cables to be sure they are in good condition.
- Test your brakes in the beginning of your ride to make sure that they are operating properly.
- Learn and follow the local bicycle laws and regulations, and obey all traffic signals, signs and laws while you ride.

If you ever any comments, questions or concerns, please contact your nearest Campagnolo Service Center. A list of service centers may be found on our website at www.campagnolo.com.

IMPORTANT! COMPATIBILITY NOTE

The part you have is the result of numerous engineering operations carried out on various parts in order to improve the overall performance of the drivetrain unit.

The use of parts which do not belong to this range may significantly reduce the overall performance of the drivetrain, therefore we recommend not mixing parts from the old ranges with those from the new.

In order to help you and to enhance performance, Campagnolo has introduced a distinctive mark (a boxed letter as illustrated here) on the new Super Record, Record and Chorus unit parts in order to point out their compatibility. Therefore, please ensure that the letter in the parts that operate for shifting (right-hand ErgoPower or bar end and rear derailleur) and in the parts that operate for derailings (left-hand ErgoPower or bar end and front derailleur, crankset and bottom bracket cup) correspond.

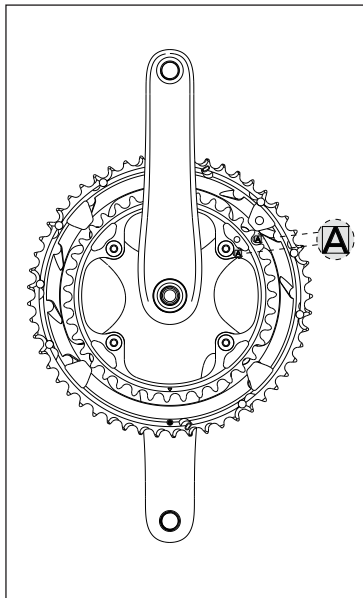

5 - USE

The crankset (Fig. 1) is the component of the bicycle's drivetrain that transfers the force applied via the pedals to the chain.

- A - hand crank
- B - chainrings
- C - bottom bracket
- D - hole for the pedal

The type of crankset is Ultra-Torque, with the semiaxles connected via a Hirth coupling, which is compatible with the most common bottom bracket shells, for which Campagnolo has implemented specific bottom bracket cups.

⚠ WARNING!

Do not put washers between the pedal axle and hand crank as they would give rise to abnormal tensions in the interface area. Such tensions could lead to premature breaks and be the cause of accidents, physical injuries or even death.

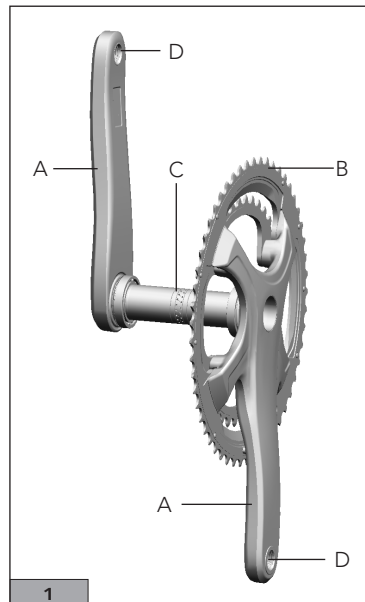

The threaded holes for the pedals located on the hand crank are type 9/16" x 20 TPI. The thread of the left hand crank is left-handed (Fig. 2), therefore turn the pivot of the pedal anticlockwise to fit the pedal, whereas the thread of the right hand crank is right-handed (Fig. 3), therefore turn the pivot of the pedal clockwise to fit the pedal. Observe the tightening torque indicated by the pedal manufacturer.

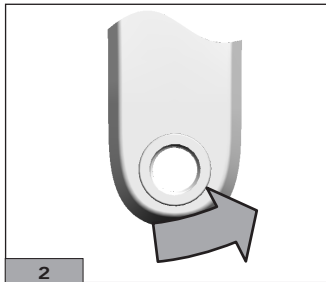

The chainrings of the crankset can be replaced by selecting combinations of chainrings that differ from the original. The available Campagnolo chainring pairs are: 50-34, 52-36, 53-39.

Contact your local mechanic to have the chainrings replaced. For maximum compatibility and efficiency, use only original Campagnolo components.

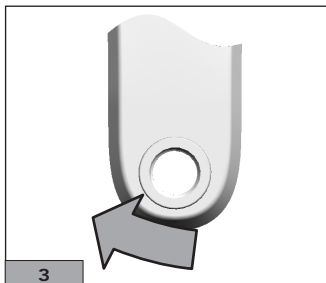

WARNING!

Campagnolo spare parts must only be installed by qualified personnel with specialised knowledge, suitable tools and sufficient experience and who carefully follow the installation instructions. Failure to comply with the above could result in product malfunctions, accidents, physical injury or death.

6 - PERIODIC INSPECTIONS

Before each use or after falling or bumping into external elements, make sure none of the following problems are present:

- abnormal noise coming from the crankset
- play when pushing or pulling the crankset laterally
- cracks or damage on the hand cranks
- bottom bracket cups not in the correct position
- chainrings with worn/damaged teeth
- chainring blocking screws damaged/not in position

Also make sure that the chain does not have any problems (oxidised, worn, damaged or jammed links).

If you find one or more of these problems or if you have doubts about the correct operation of the crankset, contact specialised personnel as indicated in the assembly/disassembly chapter.

7 - MAINTENANCE / LUBRICATION / CLEANING

- The duration of the components is variable based on the conditions of use, frequency and quality of maintenance. For proper component maintenance, it is necessary to frequently perform the cleaning and lubrication operations, especially under conditions of heavy use (e.g. each time after washing the bicycle, after use in wet conditions, on dusty or muddy roads etc.).
- Check chapter 8 to determine the frequency with which you should have maintenance performed on your components by a specialised mechanic: Period maintenance.
- Dirt seriously damages the bicycle and its components. Wash, clean and dry your bicycle carefully after use.
- Never spray your bicycle with water under pressure. Pressurized water, even from the nozzle of a small garden hose, can pass under seals and enter your Campagnolo components, thereby affecting its operation. Wash your bicycle and Campagnolo components by wiping them down with water and neutral soap.

 **WARNING!**

Salty environments (such as winter roads or roads near the sea) may lead to galvanic corrosion of most of the bicycle's exposed components. To prevent damage, malfunctions and accidents, rinse, dry and carefully re-lubricate all components which are subject to this phenomenon.

- Do not expose the products to high temperature, do not leave them closed in cars parked under the sun, do not keep them near radiators or other heat sources, do not leave carbon or plastic products in direct sunlight.

7.1 - PROCEDURE FOR CRANKSET CLEANING AND LUBRICATION

- Before lubricating, carefully clean the drivetrain (system, sprocket pack, chainrings and rear derailleur wheels) with a brush or cloth soaked in a specific degreaser/detergent. In the case of dust or mud, remove any residuals with specific plastic tools.
- Dry the drivetrain with a soft cloth: never use abrasive sponges or metal scouring pads.
- Carefully lubricate the components, using a specific chain lubricant.
- After application, turn the hand cranks using all the possible gear combinations in order to properly lubricate the entire drivetrain.
- Carefully clean any remaining lubricant remaining on the bicycle or the floor.
- At the end of the lubrication operations, CAREFULLY degrease the braking rim and the brake blocks.

 **WARNING!**

Residual lubricant on the rims and the brake blocks can reduce or cancel out the braking performance of your bicycle and be the cause of accidents, physical injury or death.

