

AXW
Magnetic Flowmeter
Remote Flowtube

IM 01E25D11-01EN

vigilantplant.®

AXW

Magnetic Flowmeter

Remote Flowtube

IM 01E25D11-01EN 2nd Edition

Contents

1.	INTRODUCTION.....	1-1
1.1	Using the Magnetic Flowmeter Safely	1-2
1.2	Warranty	1-3
1.3	Combination Remote Converters	1-3
2.	HANDLING PRECAUTIONS.....	2-1
2.1	Checking Model and Specifications	2-1
2.2	Storage Precautions	2-1
2.3	Installation Location Precautions	2-1
3.	INSTALLATION	3-1
3.1	Piping Design Precautions	3-1
3.2	Handling Precautions	3-3
3.2.1	General Precautions	3-3
3.2.2	Flowmeter Piping	3-4
3.3	Mounting Procedures	3-4
4.	WIRING	4-1
4.1	Wiring the Remote Flowtube	4-1
4.1.1	Wiring Precautions	4-1
4.1.2	Cables	4-2
4.1.3	Wiring Ports	4-3
4.1.4	Wiring Connections	4-4
5.	MAINTENANCE.....	5-1
5.1	Changing Direction of Electrical Connection	5-1
5.2	Regular Inspection Items	5-2
5.3	Excitation Coil and Insulation Resistance Check	5-2
5.4	Troubleshooting	5-3
5.4.1	No Indication	5-3
5.4.2	Unstable Zero	5-4
5.4.3	Disagreement Between Indication and Actual Flow	5-5
6.	OUTLINE.....	6-1
■	STANDARD SPECIFICATIONS	6-1
■	STANDARD PERFORMANCE	6-1
■	NORMAL OPERATING CONDITIONS.....	6-2
■	MODEL AND SUFFIX CODE	6-3

■	OPTIONAL SPECIFICATIONS	6-5
■	OPTIONAL SPECIFICATIONS (continued).....	6-6
■	DIMENSIONAL DRAWINGS	6-7
■	SIZING DATA.....	6-19
	Revision Information	i

1. INTRODUCTION

This instrument has been adjusted at the factory before shipment.

To ensure correct use of the instrument, please read this manual thoroughly and fully understand how to operate the instrument before operating it.



NOTE

The ADMAG AXW remote flowtube is used in combination with the AXFA11 remote converter. This manual describes the hardware configuration of the ADMAG AXW remote flowtube. For details of the AXFA11 remote converter, see IM 01E20C01-01E instruction manual.

When setting the parameter “C30” in the remote converter, select “ADMAG AXF” for ADMAG AXW remote flowtube.

■ Regarding This User’s Manual

- This manual should be provided to the end user.
- Before use, read this manual thoroughly to comprehend its contents.
- The contents of this manual may be changed without prior notice.
- All rights are reserved. No part of this manual may be reproduced in any form without Yokogawa’s written permission.
- Yokogawa makes no warranty of any kind with regard to this material, including, but not limited to, implied warranties of merchantability and suitability for a particular purpose.
- All reasonable effort has been made to ensure the accuracy of the contents of this manual. However, if any errors or omissions are found, please inform Yokogawa.
- Yokogawa assumes no responsibilities for this product except as stated in the warranty.
- Please note that this user’s manual may not be revised for any specification changes, construction changes or operating part changes that are not considered to affect function or performance.
- If the customer or any third party is harmed by the use of this product, Yokogawa assumes no responsibility for any such harm owing to any defects in the product which were not predictable, or for any indirect damages.

■ Safety and Modification Precautions

- The following general safety precautions must be observed during all phases of operation, service, and repair of this instrument. Failure to comply with these precautions or with specific WARNINGS given elsewhere in this manual violates safety standards of design, manufacture, and intended use of the instrument. Yokogawa assumes no liability for the customer’s failure to comply with these requirements. If this instrument is used in a manner not specified in this manual, the protection provided by this instrument may be impaired.
- Yokogawa will not be liable for malfunctions or damage resulting from any modification made to this instrument by the customer.
- The following safety symbol marks are used in this user’s manual and instrument.



WARNING

A WARNING sign denotes a hazard. It calls attention to procedure, practice, condition or the like, which, if not correctly performed or adhered to, could result in injury or death of personnel.



CAUTION

A CAUTION sign denotes a hazard. It calls attention to procedure, practice, condition or the like, which, if not correctly performed or adhered to, could result in damage to or destruction of part or all of the product.



IMPORTANT

An IMPORTANT sign denotes that attention is required to avoid damage to the instrument or system failure.



NOTE

A NOTE sign denotes information necessary for essential understanding of operation and features.

- ⊕ Protective grounding terminal
- ⊕ Functional grounding terminal
(This terminal should not be used as a protective grounding terminal.)
- ~ Alternating current
- Direct current

1.1 Using the Magnetic Flowmeter Safely

(1) Installation



WARNING

- Installation of the magnetic flowmeter must be performed by expert engineer or skilled personnel. No operator shall be permitted to perform procedures relating to installation.
- The magnetic flowmeter must be installed within the specification conditions.
- The magnetic flowmeter is a heavy instrument. Be careful that no damage is caused to personnel through accidentally dropping it, or by exerting excessive force on the magnetic flowmeter. When moving the magnetic flowmeter, always use a trolley, forklift, or crane and have at least two people carry it.
- When the magnetic flowmeter is processing hot fluids, the instrument itself may become extremely hot. Take sufficient care not to get burnt.
- Where the fluid being processed is a toxic substance, avoid contact with the fluid and avoid inhaling any residual gas, even after the instrument has been taken off the piping line for maintenance and so forth.
- Do not apply excessive weight, for example, a person stepping on the magnetic flowmeter.
- All procedures relating to installation must comply with the electrical code of the country where it is used.

(2) Wiring



WARNING

- The wiring of the magnetic flowmeter must be performed by expert engineer or skilled personnel. No operator shall be permitted to perform procedures relating to wiring.
- When connecting the wiring, check that the supply voltage to the converter is within the range of the voltage specified for this instrument before connecting the power cable. In addition, check that no voltage is applied to the power cable before connecting the wiring.
- The protective grounding must be connected securely at the terminal with the ⊕ mark to avoid danger to personnel.

(3) Operation



WARNING

- When opening the cover, wait for more than 10 minutes after turning off the power. Only expert engineer or skilled personnel are permitted to open the cover.
- Do not open the cover in wet weather or humid environment. When the cover is open, stated enclosure protection is not applicable.
- Be sure to set parameters as “Protect” on the write protect function after finish of parameter setting work.
Under extremely rare case, the infra-red switches may respond unexpectedly in such conditions as sticking ball of water or extraneous substances on the surface of display panel glass according to the principle of infra-red switch operation.
Its probability rises in such cases as sticking rain water by storm or other similar situation and washing up work near flowmeter installation place.
Either to illuminate or stop illuminating the infra-red switches by the flashlight may cause the mis-reaction.
Refer to the manual for converter on how to use the write protect function in detail.

(4) Maintenance

**WARNING**

- Maintenance of the magnetic flowmeter should be performed by the trained personnel having knowledge of safety standard. No operator shall be permitted to perform any operations relating to maintenance.
- When opening the cover, wait for more than 10 minutes after turning off the power.
- Do not open the cover in wet weather or humid environment. When the cover is open, stated enclosure protection is not applicable.
- Always conform to maintenance procedures outlined in this manual. If necessary, contact Yokogawa.
- Care should be taken to prevent the build up of dirt, dust or other substances on the display panel glass or data plate. If these surfaces do get dirty, wipe them clean with a soft dry cloth.

1.2 Warranty

- The terms of this instrument that are guaranteed are described in the quotation. We will make any repairs that may become necessary during the guaranteed term free of charge.
- Please contact our sales office if this instrument requires repair.
- If the instrument is faulty, contact us with concrete details about the problem and the length of time it has been faulty, and state the model and serial number. We would appreciate the inclusion of drawings or additional information.
- The results of our examination will determine whether the meter will be repaired free of charge or on an at-cost basis.

■ The guarantee will not apply in the following cases:

- Damage due to negligence or insufficient maintenance on the part of the customer.
- Problems or damage resulting from handling, operation or storage that violates the intended use and specifications.
- Problems that result from using or performing maintenance on the instrument in a location that does not comply with the installation location specified by Yokogawa.
- Problems or damage resulting from repairs or modifications not performed by Yokogawa or someone authorized by Yokogawa.
- Problems or damage resulting from inappropriate reinstallation after delivery.
- Problems or damage resulting from disasters such as fires, earthquakes, storms, floods, or lightning strikes and external causes.

■ Trademarks:

ADMAG and AXW are registered trademarks of Yokogawa Electric Corporation.

Company names and product names used in this material are registered trademarks or trademarks of their respective owners.

1.3 Combination Remote Converters

**IMPORTANT**

- The AXW remote flowtube (size 500 (20 in.) to 1800 mm (72 in.)) should be used in combination with AXFA11 remote converter. Contact Yokogawa before using it in combination with converters other than AXFA11.

2. HANDLING PRECAUTIONS

This instrument has been inspected carefully at the factory before shipment. When the instrument is delivered, visually check that no damage has occurred during transportation.

Read this section carefully as it contains important information on handling this instrument. Refer to the relevant sections for information not contained in this section. If you have any problems or questions, please contact Yokogawa sales office.

2.1 Checking Model and Specifications

The model code and specifications are found on the data plate located on the outside of the case. Check that the model code and specifications match what you have ordered.

Be sure you have your model number and serial number available when contacting Yokogawa.

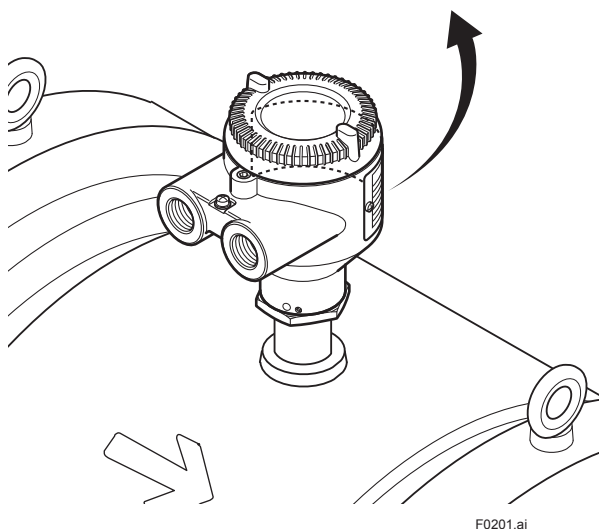
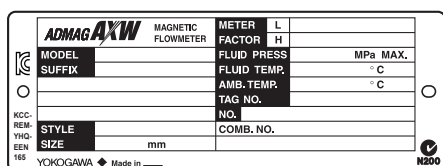

Figure 2.1.1 Data Plate

2.2 Storage Precautions

If the instrument is to be stored for a long period of time after delivery, observe the following points.

- The instrument should be stored in its original packing condition in the storage location.
- Select a storage location that fulfils the following conditions:
 - A place where it will not be exposed to rain or water
 - A place subject to minimal vibrations or shocks
 - Temperature and humidity levels should be as follows:

Temperature: -10 to 70°C

Humidity: 5 to 80% RH (no condensation)

The preferred ambient temperature and humidity levels are 25°C and approximately 65% RH.

- If the magnetic flowmeter is transferred to the installation site and stored without being installed, its performance may be impaired due to the infiltration of rainwater and so forth. Be sure to install and wire the magnetic flowmeter as soon as possible after transferring it to the installation location.

2.3 Installation Location Precautions

Select the installation location with consideration to the following items to ensure long-term stable operation of the instrument.

- **Ambient Temperature:**
Avoid installing the instrument in locations with constantly fluctuating temperatures. If the location is subject to radiant heat from the plant, provide heat insulation or improve ventilation.
- **Atmospheric Condition:**
Avoid installing the instrument in a corrosive atmosphere. In situations where this is unavoidable, consider ways to improve ventilation and to prevent rainwater from entering and being retained in the conduit pipes.
- **Vibrations or Shocks:**
Avoid installing the instrument in a place subject to shocks or vibrations.

3. INSTALLATION



WARNING

Installation of the magnetic flowmeter must be performed by expert engineer or skilled personnel. No operator shall be permitted to perform procedures relating to installation.

3.1 Piping Design Precautions



IMPORTANT

Design piping correctly, referring to the following to prevent damage to flowtubes and to assure accurate measuring.

(1) Location



IMPORTANT

Install the flowmeter in a location where it is not exposed to direct sunlight. The minimum ambient temperature is limited by the minimum fluid temperature of the flowtube (the lining). For more information, refer to Chapter 6 “OUTLINE”. The flowmeter may be used in an ambient humidity where the relative humidity ranges from 0 to 100%. However, avoid long-term continuous operation at relative humidity above 95%.

(2) Noise Avoidance



IMPORTANT

The flowmeter should be installed away from electrical motors, transformers, and other power sources in order to avoid interference with measurement.

(3) Required Lengths of Straight Runss

To maintain accurate measurement, see JIS B7554 “Electro Magnetic Flowmeters” which explains the requirements for upstream piping conditions of magnetic flowmeters.

Based on JIS B7554 “Electro Magnetic Flowmeters” and our piping condition test data, we recommend the piping conditions as shown in the following

figures.

When installing two or more magnetic flowmeters on a single pipe, provide a run of at least 10D between them.

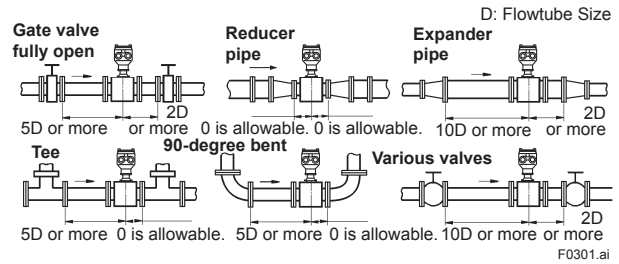

Figure 3.1.1 Required Lengths of Straight Runs

- *1: Do not install anything in the vicinity that may interfere with the magnetic field, induced signal voltages, or flow velocity distributions of the flowmeter.
- *2: A straight run may not be required on the downstream side of the flowmeter. However, if a downstream valve or other fitting causes irregularity or deviation in flows, provide a straight run of 2D to 3D on the downstream side.
- *3: The valves shall be mounted on the downstream side so that deviated flows do not occur in the flowtube and to avoid startup from an empty condition.

(4) Maintaining Stable Fluid Conductivity



IMPORTANT

Do not install the flowmeter where fluid conductivity tends to become uneven. If chemicals are fed near the upstream side of a magnetic flowmeter, they may affect the flow rate's indications. To avoid this situation, it is recommended that the chemical feed ports be located on the downstream side of the flowmeter. If it is unavoidable that chemicals must be fed on the upstream side, provide a sufficient length of straight run (approximately 50D) to ensure the proper mixture of fluids.

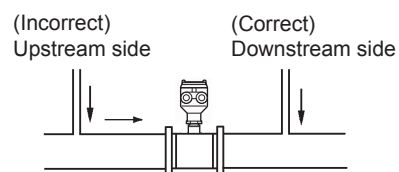

F0302.ai

Figure 3.1.2 Chemical Injection

(5) Precautions for Use of Liquid Sealing Compounds



IMPORTANT

Care must be taken in using liquid sealing compounds on the piping, as it may have a negative influence on the flow indications by flowing out and covering the surfaces of an electrode or grounding ring. In particular, care must be taken if a liquid sealing compound is used in the case of vertical piping.

(6) Service Area

Select locations where there is adequate space to service installing, wiring, overhauling, etc

(7) Bypass Line

It is recommended to install a bypass line to facilitate maintenance and zero adjustment.

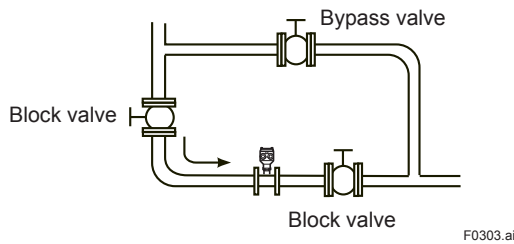

Figure 3.1.3 Bypass Line

(8) Supporting the Flowmeter



CAUTION

Do not secure the flowmeter separately to prevent the vibrations, shocks, and expansion and contraction forces of the piping from affecting it. Fix the pipeline or its flanges first, then let them support the flowmeter. For vertical, mounting, make sure that the weight of piping does not weigh on the flowmeter. To release the load from tightening the flowmeter to the pipeline, set a expansive pipe in the downstream side.

(9) Mounting Positions

- Pipes must be fully filled with liquids.



IMPORTANT

It is essential that pipes remain fully filled at all times, otherwise flow rate indications may be affected and measurement errors may be caused.

Piping shall be designed so as to maintain the interior of the flowtube filled with fluids.

Vertical mounting is effective in such cases as when fluids tend to separate or solid matter may be precipitated. When employing vertical mounting, direct the fluids from the bottom to the top to ensure that the pipes remain fully filled.

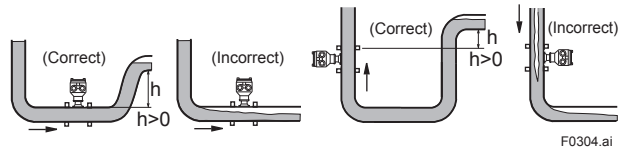

Figure 3.1.4 Mounting Positions

- Avoid air bubbles.



IMPORTANT

If air bubbles enter a measurement pipe, flow rate indications may be affected and measurement errors may be caused.

In cases where fluids contain air bubbles, piping must be designed to prevent them from accumulating in the measurement pipe of a flowtube.

If a valve exists near the flowmeter, try to mount the flowmeter on the valve's upstream side in order to prevent a possible reduction of pressure inside the pipe, thereby avoiding the possibility of air bubbles.

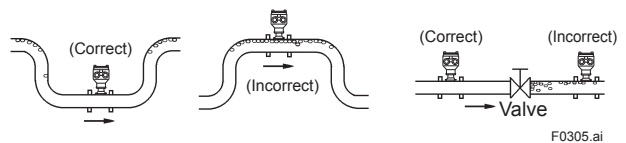

Figure 3.1.5 Avoiding Air Bubbles

• **Mounting orientation**



IMPORTANT

If electrodes are perpendicular to the ground, air bubbles near the top or precipitates at the bottom may cause measurement errors. Ensure that the terminal box of a remote flowtube is mounted above the piping to prevent water from entering them.

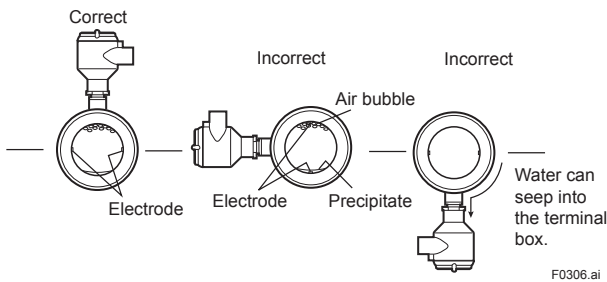

Figure 3.1.6 Mounting Orientation

3.2 Handling Precautions



WARNING

The magnetic flowmeter is a heavy instrument. Be careful that no damage is caused to personnel through accidentally dropping it, or by exerting excessive force on the magnetic flowmeter. When moving the magnetic flowmeter, always use a trolley, forklift, or crane and have at least two people carry it.

3.2.1 General Precautions

(1) Precaution during Transportation

The magnetic flowmeter is packed tightly. When it is unpacked, pay attention to prevent damaging the flowmeter. To prevent accidents while it is being transported to the installing location, transport it to the site in its original packing.



CAUTION

When lifting the flowtube, use the lifting rings (eye bolts or eye plates) as in Figure 3.2.1. Never lift it using a bar passed through the flowtube as this damages the liner severely.

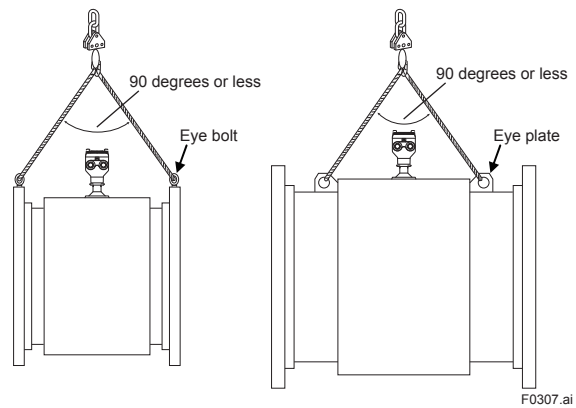

Figure 3.2.1 Lifting Flowtube

(2) Avoiding Shocks from Impact



CAUTION

Care should be taken not to drop the flowmeter or expose it to excessive shock. In particular, be careful not to subject the flange surface to shock. This may lead to liner damage which will result in inaccurate readings.

(3) Flange Protection Covers



IMPORTANT

Keep the protective covering (i.e. the corrugated cardboard or other cushioning material) in place over the flange except when mounting the flowmeter to the pipe.

(4) Terminal Box Cover



IMPORTANT

As it is possible that the insulation will deteriorate, do not remove the wrapping of the terminal box nor open the terminal box cover until it is time to wire it.

(5) Long-term Non-use



IMPORTANT

It is not desirable to leave the flowmeter unused for a long term after installation. If this situation is unavoidable, take care of the flowmeter by observing the following.

- **Confirmation of sealing conditions for the flowmeter**

Confirm that the terminal box screw and wiring ports are well sealed. Equip the conduit piping with drain plugs or waterproof glands to prevent moisture or water from penetrating into the flowmeter through the conduit.

- **Regular inspections**

Inspect the sealing conditions as mentioned above, and the inside of the terminal box at least once a year. Also, due to rain, etc. when it is suspected that water may have penetrated into the inside flowmeter perform supplementary inspections.

3.2.2 Flowmeter Piping

 **CAUTION**

Misaligned or slanted piping can lead to leakage and damage to the flanges.

- (1) Correct any misaligned or slanted piping, and any gaps that may exist between mounting flanges before installing the flowmeter (refer to Figure 3.2.2).

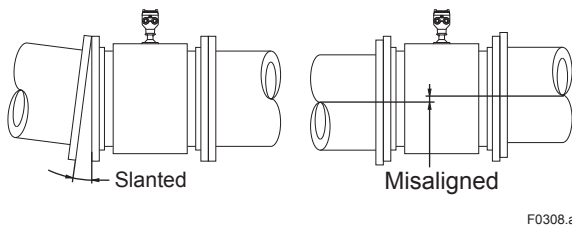

Figure 3.2.2 Slanted and Misaligned Flowmeter Piping

- (2) Inside a newly installed pipeline, there may be some foreign substances such as residue from welding or wood chips. Remove them by flushing the piping before mounting the flowmeter. This prevents the lining from being damaged, as well as the occurrence of erroneous measured signals resulting from foreign substances passing through the flowtube during measurement.

3.3 Mounting Procedures

 **CAUTION**

When attaching optional grounding rings to the flowtube with lining material natural hard rubber or fluorocarbon PTFE, gaskets must be placed between each grounding ring and the flowtube. Fluid leakage will happen without these gaskets. These gaskets are to be supplied by customer. Do not forget those gaskets also when ordering and attaching the grounding rings later additionally.

 **NOTE**

The tightening torque value varies depending on the type of lining and gasket as shown in the tables in this section.

 **IMPORTANT**

Use bolts and nuts in compliance with the flange ratings. When choosing the gaskets, be sure to choose sheet gaskets designed to fit for flange standard.

(1) Mounting Direction

Mount the flowmeter so that the flow direction of the fluid to be measured is in line with the direction of the arrow mark on the flowmeter. It may be especially difficult to move large size flowtubes after bringing them into the pit. Check directions before bringing.

 **IMPORTANT**

If it is impossible to match the direction of the arrow mark, the direction of the electrical connection can be changed. Refer to Section 5.1 to do this properly.

In case the fluid being measured flows against the arrow direction, refer to the parameter **J20: Flow Direction** in the user's manual of the AXFA11 Magnetic Flowmeter Remote Converter (IM 01E20C01-01E).

(2) Carrying Flowtube

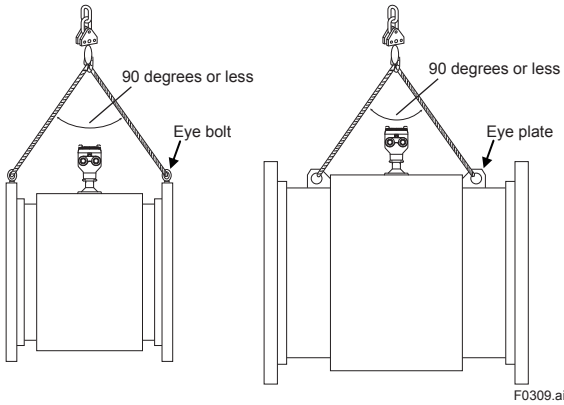

Figure 3.3.1 Carrying Flowtube

CAUTION

- When carrying the flowtube, use the lifting rings (eye bolts or eye plates).
- To assure safety, keep lifting angle less than 90 degrees as shown in Figure 3.3.1

(3) Positioning Flowtube

Bring in the flowtube, place it and use a jack to adjust its position.

IMPORTANT

Apply the jack to the flanges of the flowtube. In addition, adjust any misalignment when the flowtube is brought in, as the jack can adjust vertical position, but not horizontal one.

(4) Applying Gasket and optional Grounding Rings

Gasket:

Necessary gaskets for piping connection are as below depending on the choice of grounding rings.

Use sheet gaskets designed to fit for flange standard. The GF type-1 gaskets by JIS G 3443-2 should be used for the JIS F12 flange models in sizes 1100 mm (44 in.) and above. In this case, the gasket groove is required on the customer pipe flanges.

The thickness of gasket should be 2mm (0.08in.) to 5mm (0.2in.) for sizes up to 1000 mm (40 in.), and 5 mm (0.2 in.) or more for larger sizes. The type of gasket should be a kind of soft rubber, or its equivalent in hardness.

1. Standard (no grounding rings)

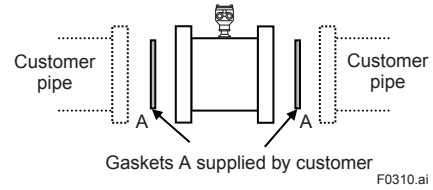

Figure 3.3.2 Installation without Grounding Rings

When using the GF type-1 gaskets, the gasket groove is required as mentioned above.

2. With optional grounding rings (code GR1)

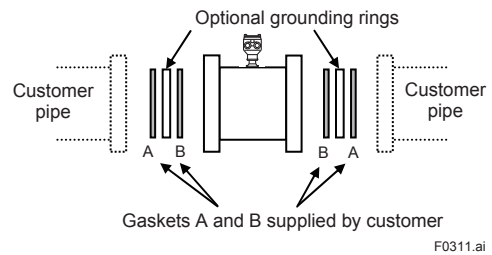

Figure 3.3.3 Installation with Grounding Rings GR1

It is recommended to use the same gasket for A and B. Both gaskets A and B are to be supplied by customer.

When polyurethane or natural soft rubber lining, the gaskets B are not necessary.

3. With optional grounding rings (code GR2)

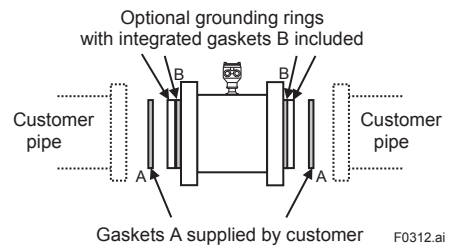

Figure 3.3.4 Installation with Grounding Rings GR2

This is available for the models with process connection JIS F12 (JIS 75M) in sizes 1100 mm (44 in.) and above. Only gaskets A are to be supplied by customer. The grounding rings are installed and locked onto the flowtube with gaskets B when shipped from factory.

Mounting Procedure (no Grounding Rings):

Connect the flowtube's flange and the customer's pipe which contact process fluid by some wire supplied by customer.

Mounting Procedure (with optional Grounding Rings GR1 for sizes up to 1000 mm (40 in.)):

1. Handles of the grounding ring have some holes which correspond to outer diameter of each flange type. There are printings near each hole. The printings show types of flange. See the table below.

Printing	Process Connection Code	Flange Standard
ASME	-CA1	ASME B16.5 Class 150, ASME B16.47 Class 150
AWWA	-CB1	AWWA C207 Class D
PN10	-CE1	EN1092-1 PN10
PN16	-CE2	EN1092-1 PN16
10K	-CJ1	JIS B2220 10K
AS	-CS1, -CS2, -CT1	AS2129 table D, E AS4087 PN16
F12	-CG1	JIS F12 (JIS 75M)

2. Confirm the centering pin is fixed to the hole corresponding to flange or fix the centering pin to the correct hole.
3. Hang the grounding rings with their flange type printings outer side of the flowtube. Set the angle of both handles symmetrically to be 45 degree from top. If there are any bolt-holes under the handles, turn the grounding rings clockwise in order to locate handles between bolt-holes. Center the grounding ring to the center of the flowtube.
4. Connect the wire from the grounding ring to the screw of the flowtube's flange and fix the wire by the nut. This procedure (item 1 to 4) must be done for the both sides of the flowtube.

5. Install the flowtube into the customer's pipe with the gaskets A.

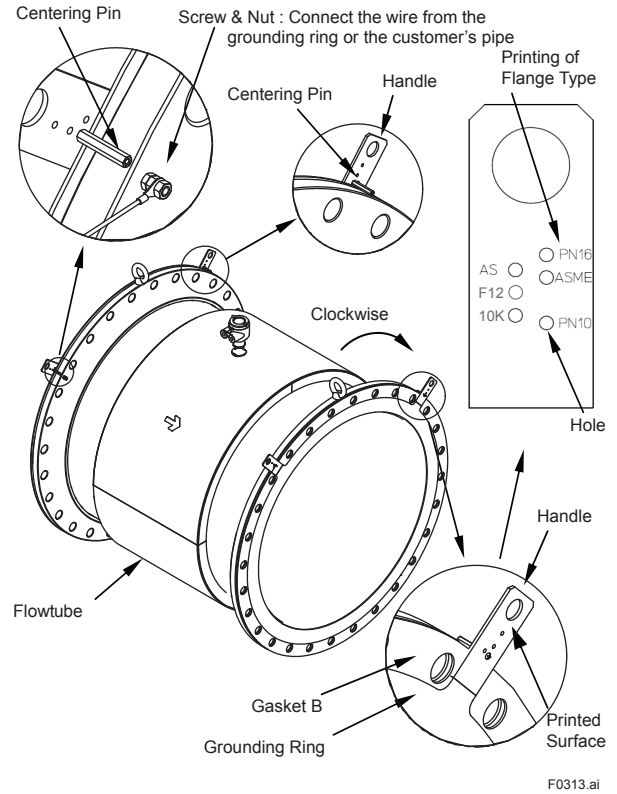

Note : Gasket A and B are also placed concentrically with the flowtube.

Figure 3.3.5 Mounting Procedure with Grounding Rings GR1 for sizes up to 1000 mm (40 in.)

Mounting Procedure (with optional Grounding Rings GR1 for sizes 1100mm (44 in.)) and above :

1. The grounding ring is temporarily fixed onto the flowtube by four bolts. Hang the grounding ring up using a crane or a hoist so that it would not fall down from the flowtube while setting the gasket B.
2. Unfasten the bolts and remove the grounding ring off from the flowtube.
3. Place the gasket B to the flowtube. Cut out holes on the gasket B if necessary, so that the bolts can go through. Fix the grounding ring to the flowtube by the four bolts again.
4. Connect the wire from the grounding ring to the screw at the flowtube flange and fix the wire by the nut. This procedure (item 1 to 4) must be done for the both sides of the flowtube.

5. Install the flowtube into the customer's pipe with the gaskets A.

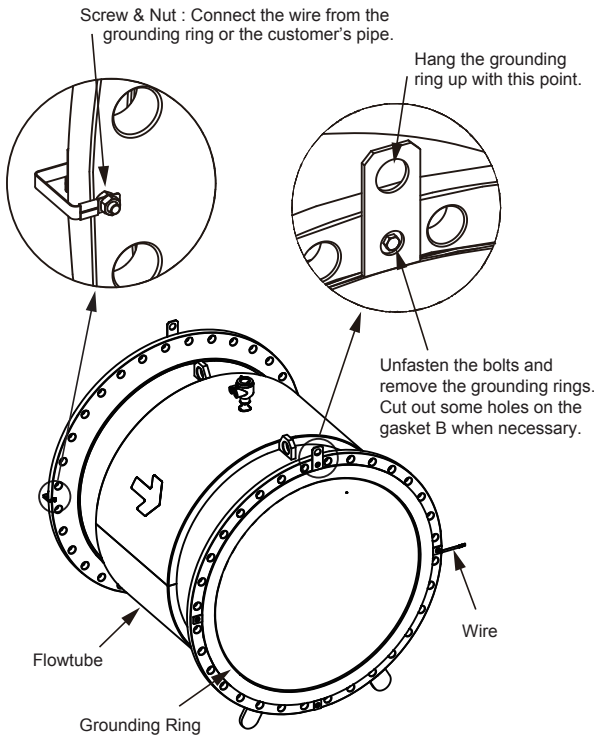

F0314.ai

Note : Gasket A and B should be placed concentrically with the flowtube.

Figure 3.3.6 Mounting Procedure with Grounding Rings GR1 for sizes 1100 mm (44 in.) and above

Mounting Procedure (with optional Grounding Rings GR2):

The grounding rings are installed and locked onto the flowtube with gaskets B when shipped from factory. Install the flowtube into the customer's pipe with gaskets A supplied by customer.

(5) Tightening Nuts

Pass the bolts from pipe line side, not flowtube side, and tighten the bolts according to the torque values for the metal piping in Table 3.3.1 or 3.3.2

CAUTION

- Be sure to tighten the nuts according to the prescribed torque values. Tighten them diagonally with the same torque values, step by up to the prescribed torque value.

Table 3.3.1 Tightening Torque Values for Metal Piping (N-m)

Unit: N-m

Lining type	PTFE / Natural hard rubber / Natural soft rubber				
Gasket type	Soft rubber gasket, or the equivalent in hardness (supplied by customer)				
Process connection Size mm (inch)	ASME B16.5 (500, 600) B16.47 (700-1000) Class 150	EN1092-1 PN10 JIS B2220 10K	EN 1092-1 PN16	AWWA C207 Class D	AS2129 Table D, E AS4087 PN16
500 (20)	99 to 166	85 to 140	143 to 238		151 to 233
600 (24)	144 to 240	108 to 175	218 to 363		239 to 331
700 (28)	168 to 281	176 to 266	180 to 300	176 to 293	240 to 333
800 (32)	259 to 432	212 to 302	236 to 393	246 to 410	400 to 612
900 (36)	274 to 457	206 to 338	224 to 373	258 to 430	399 to 604
1000 (40)	274 to 457	277 to 422	307 to 512	286 to 477	422 to 587

Unit: N-m

Lining type	Polyurethane rubber					
Gasket type	Soft rubber gasket, or the equivalent in hardness (supplied by customer)					
Process connection Size mm (inch)	ASME B16.5 (500, 600) B16.47 (700-1000) Class 150	EN1092-1 PN10 JIS B2220 10K	EN 1092-1 PN16	AWWA C207 Class D	AS2129 Table D, E AS4087 PN16	JIS F12 (JIS 75M)
500 (20)	71 to 118	60 to 99	74 to 123		76 to 123	131 to 218
600 (24)	97 to 162	82 to 126	101 to 168		118 to 171	124 to 206
700 (28)	125 to 208	135 to 202	146 to 244	120 to 200	167 to 242	202 to 337
800 (32)	176 to 294	160 to 229	190 to 316	169 to 281	218 to 348	197 to 328
900 (36)	170 to 283	151 to 251	178 to 296	161 to 268	200 to 317	221 to 369
1000 (40)	175 to 291	206 to 314	220 to 367	165 to 275	253 to 370	218 to 363

Unit: N-m

Lining type	Natural hard rubber				Polyurethane rubber
Gasket type	Soft rubber gasket, or the equivalent in hardness (supplied by customer)				
Process connection Size mm (inch)	EN1092-1 PN6	EN1092-1 PN10	AWWA C207 Class D	AS2129 Table D, E AS4087 PN16	JIS F12 (JIS 75M)
1100 (44)					285 to 476
1200 (48)	180 to 300	327 to 546	298 to 497	400 to 582	281 to 468
1350 (54)					397 to 662
1400 (56)	233 to 388	379 to 632			
1500 (60)					421 to 702
1600 (64)	238 to 397	532 to 886			532 to 887
1800 (72)	291 to 485	552 to 919			468 to 779

Table 3.3.2 Tightening Torque Values for Metal Piping (lbf-in)

Unit: lbf-in

Lining type	PTFE / Natural hard rubber / Natural soft rubber				
Gasket type	Soft rubber gasket, or the equivalent in hardness (supplied by customer)				
Process connection Size mm (inch)	ASME B16.5 (500, 600) B16.47 (700-1000) Class 150	EN1092-1 PN10 JIS B2220 10K	EN 1092-1 PN16	AWWA C207 Class D	AS2129 Table D, E AS4087 PN16
500 (20)	880 to 1467	748 to 1239	1266 to 2110		1332 to 2062
600 (24)	1275 to 2125	955 to 1546	1928 to 3214		2113 to 2932
700 (28)	1490 to 2483	1561 to 2357	1594 to 2657	1558 to 2596	2123 to 2943
800 (32)	2292 to 3820	1880 to 2671	2085 to 3475	2176 to 3627	3538 to 5413
900 (36)	2426 to 4043	1821 to 2991	1980 to 3301	2285 to 3809	3535 to 5346
1000 (40)	2426 to 4043	2450 to 3739	2717 to 4528	2534 to 4224	3734 to 5265

Unit: lbf-in

Lining type	Polyurethane rubber					
Gasket type	Soft rubber gasket, or the equivalent in hardness (supplied by customer)					
Process connection Size mm (inch)	ASME B16.5 (500, 600) B16.47 (700-1000) Class 150	EN1092-1 PN10 JIS B2220 10K	EN 1092-1 PN16	AWWA C207 Class D	AS2129 Table D, E AS4087 PN16	JIS F12 (JIS 75M)
500 (20)	626 to 1044	527 to 876	652 to 1087		674 to 1089	1159 to 1931
600 (24)	862 to 1436	727 to 1113	894 to 1490		1043 to 1512	1095 to 1825
700 (28)	1106 to 1843	1193 to 1791	1295 to 2159	1061 to 1769	1478 to 2142	1788 to 2980
800 (32)	1562 to 2603	1420 to 2024	1680 to 2800	1494 to 2491	1926 to 3076	1739 to 2899
900 (36)	1505 to 2508	1340 to 2218	1571 to 2619	1422 to 2370	1773 to 2808	1958 to 3263
1000 (40)	1546 to 2577	1824 to 2781	1951 to 3251	1459 to 2432	2239 to 3274	1928 to 3213

Unit: lbf-in

Lining type	Natural hard rubber				Polyurethane rubber
Gasket type	Soft rubber gasket, or the equivalent in hardness (supplied by customer)				
Process connection Size mm (inch)	EN1092-1 PN6	EN1092-1 PN10	AWWA C207 Class D	AS2129 Table D, E AS4087 PN16	JIS F12 (JIS 75M)
1100 (44)					2527 to 4211
1200 (48)	1594 to 2657	2898 to 4830	2639 to 4398	3539 to 5149	2484 to 4139
1350 (54)					3517 to 5862
1400 (56)	2060 to 3434	3358 to 5597			
1500 (60)					3729 to 6215
1600 (64)	2109 to 3515	4705 to 7842			4713 to 7854
1800 (72)	2576 to 4293	4883 to 8138			4138 to 6897

4. WIRING

4.1 Wiring the Remote Flowtube

This section describes the wiring of the remote flowtube only. For information relating to the wiring of the converter, refer to the user's manual of the AXFA11 Magnetic Flowmeter Remote Converter (IM 01E20C01-01E).



WARNING

The wiring of the magnetic flowmeter must be performed by expert engineer or skilled personnel. No operator shall be permitted to perform procedures relating to wiring.



CAUTION

Once all wiring is complete, check the connections before applying power to the instrument. Improper arrangements or wiring may cause a unit malfunction or damage.

4.1.1 Wiring Precautions

Be sure to observe the following precautions when wiring:



CAUTION

- In cases where the ambient temperature exceeds 50°C (122°F), use external heat-resistant wiring with a maximum allowable temperature of 70°C (158°F) or above.
- Do not connect cables outdoors in wet weather in order to prevent damage from condensation and to protect the insulation, e.g. inside the terminal box of the flowtube.
- Do not splice the cable between the flowtube terminal and the converter if it is too short. Replace the short cable with a cable that is the appropriate length.
- All the cable ends must be provided with round crimp-on terminals and be securely wired.

- The signal cables must be routed in separate steel conduit tubes 16 (JIS C 8305) or flexible conduit tubes 15 (JIS C 8309).
- Keep conduits or flexible tubes watertight using sealing tape.
- Ground the remote flowtube and the converter separately.
- Cover each shield of the signal cable with vinyl tube or vinyl tape to avoid contact between two shields or between a shield and a case.
- When waterproof glands or union equipped waterproof glands are used, avoid tightening the glands with an excessive torque.
- Be sure to turn the power off before opening the terminal box cover.
- Before turning the power on, tighten the terminal box cover securely.
- When opening the terminal box cover, use a hexagonal wrench (nominal size 3 mm). For handling the locking screw, refer to Figure 4.1.7.
- Be sure to lock the cover using a hexagonal wrench (nominal size 3 mm) after installing the cover. For handling the locking screw, refer to Figure 4.1.11.
- When submersible type or optional code DHC is selected, waterproof glands, signal and excitation cables are attached. In order to preserve the effectiveness of waterproof features, the terminal box cover and waterproof glands must not be detached from flowmeter.



IMPORTANT

Prepare the signal cable and the excitation cable almost the same length. It is recommended to lay them together closely.

4.1.2 Cables

(1) Dedicated Signal Cable (AXFC)

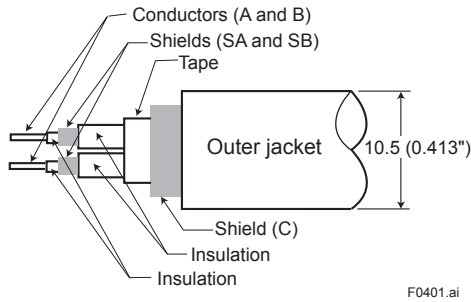

Figure 4.1.1 Dedicated Signal Cable AXFC

The flow signal is transmitted via this dedicated cable. The cable is constructed with double shielding over the two conductors, and heat-resistant vinyl is used for the outer jacket material.

Finished diameter: 10.5 mm (0.413")

Maximum length:

Combination with the AXFA11 converter:

200 m (660 ft)

Maximum temperature: 80°C (176°F)



IMPORTANT

If the cable is longer than required, cut off any extra length rather than coiling it up, and terminate the conductors as shown in Figure 4.1.2. Avoid using junction terminal boards to extend the cable length, as this will interrupt the shielding.

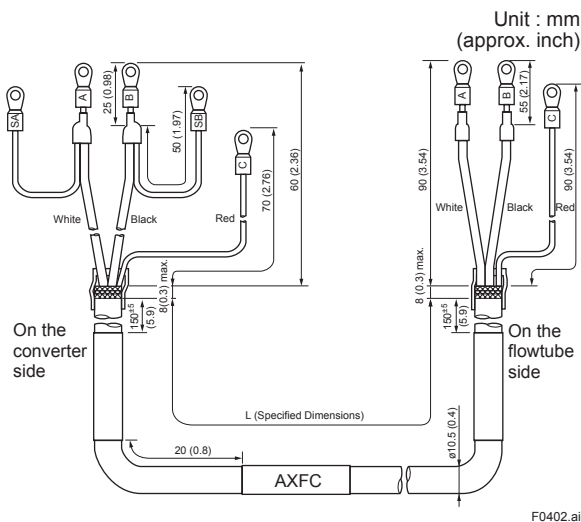

Figure 4.1.2 Treatment of Dedicated Signal Cables



CAUTION

- As crimp terminals A, B, SA, SB and C have their own electrical potentials, securely insulate them so as not to come in contact with one another.
- To prevent a shield from coming in contact with another shield or the case, cover each shield with a vinyl tube or wrap it in vinyl tape.



NOTE

Conductors A and B carry the signal from the electrodes, and C is at the potential of the liquid (signal common). Shields SA and SB are kept at the same potentials as the individual electrodes (these are actively driven shields.) This is done to reduce the effect of the distributed capacitance of the cable at long cable length. Note that, since the signals from the individual electrodes are impedance converted inside the converter, errors will result if they come in contact with any other component. Great care must be taken in the cable finish treatment.

(2) Excitation Cable

JIS C 3401 control cable equivalent

JIS C 3312 power cable equivalent

14 AWG Belden 8720 equivalent

Outer Diameter: 6.5 to 12 mm (0.26 to 0.47 in.)

10.5 or 11.5 mm (0.41 to 0.45 in.) for optional code EG, EU and EW.

Nominal Cross Section:

Single wire: 0.5 to 2.5 mm²

Stranded wire: 0.5 to 1.5 mm²

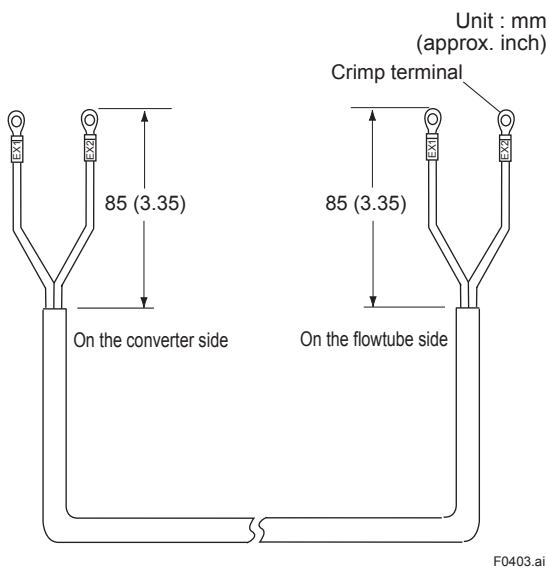

Figure 4.1.3 Finish Treatment of Excitation Cable



NOTE

- For excitation cables, always use a crimp terminal with an insulation cover.
- Use crimp tools from the manufacturer of the crimp terminal you want to use to connect the crimp terminal and cable.
- Use crimp tools that are appropriate for the diameter of the cable to be connected.

4.1.3 Wiring Ports

This instrument is of watertight construction as stipulated in JIS C0920. It is shipped with a wiring bracket (waterproof gland or waterproof gland with union), only in cases where an optional specification is selected for the wiring port. When submersible type or option code DHC is selected, waterproof glands and a 30-meter (or customer designated) length cable are attached with resin filled in the terminal box. In this case, wiring at this terminal box is not necessary and do not open it.



IMPORTANT

The wiring port is sealed with a cap (not waterproof). Do not remove the cap from the wiring port until wiring a cable. If waterproof property is necessary, please use waterproof glands.

(1) When waterproof property is unnecessary (When there are no particular optional specifications)

The wiring port is sealed with a cap (not waterproof) that must be removed before wiring. When wiring, handle the wiring with proper procedures for necessary protection.

(2) When waterproof property is necessary (Wiring using waterproof glands)



IMPORTANT

To prevent water or condensation from entering the terminal box, waterproof glands are recommended. Do not over-tighten the glands or damage to the cables may result. Tightness of the gland can be checked by confirming that the cable is held firmly in place.

For working on the electric wire tubes or the flexible tubes (G1/2), remove the waterproof gland and attach them directly to the wiring port.

Be sure to use the washers and gaskets as shown in the drawings. Check and see that the cable is firmly fixed realizing waterproofness.

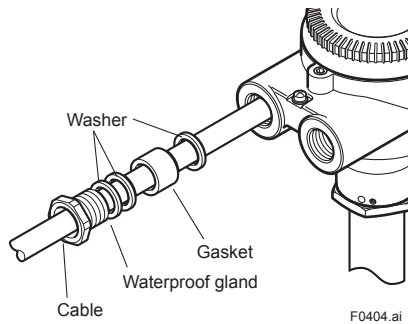

Figure 4.1.4 Waterproof Gland (Optional code EG)

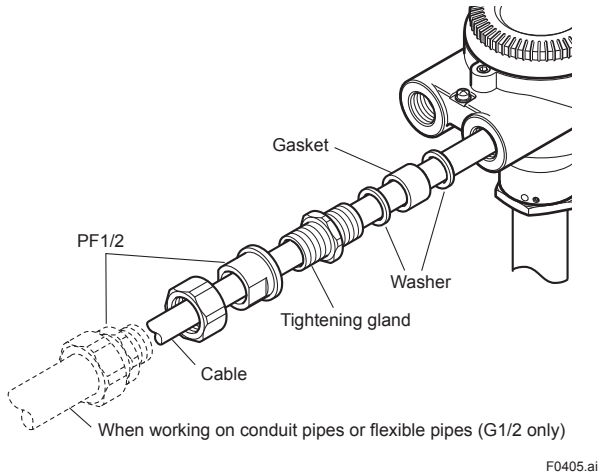

Figure 4.1.5 Waterproof Gland with Union Joint (Optional code EU)

(3) Conduit Wiring

When wiring the conduits, pass the conduit through the wiring connection port, and utilize the waterproof gland to prevent water from flowing in. Place the conduit pipe on an angle as shown in Figure 4.1.6. Install a drain valve at the low end of the vertical pipe, and open the valve regularly.

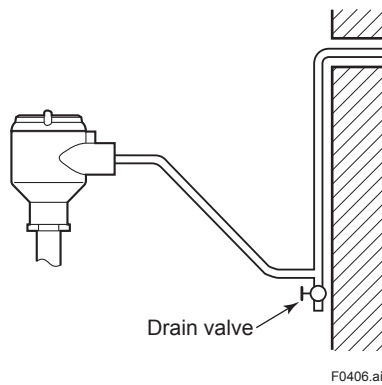

Figure 4.1.6 Conduit Wiring

4.1.4 Wiring Connections



WARNING

Before wiring, be sure that the power supply for AXFA11 converter has been turned off to prevent an electrical shock.

(1) Removing Cover

Loosen the cover locking screw clockwise using a hexagonal wrench (nominal size 3 mm) to unlock the cover. (Upon shipment from the manufacturing plant, the cover is unlocked.) Remove the cover by turning it in the direction of the arrow as shown below.

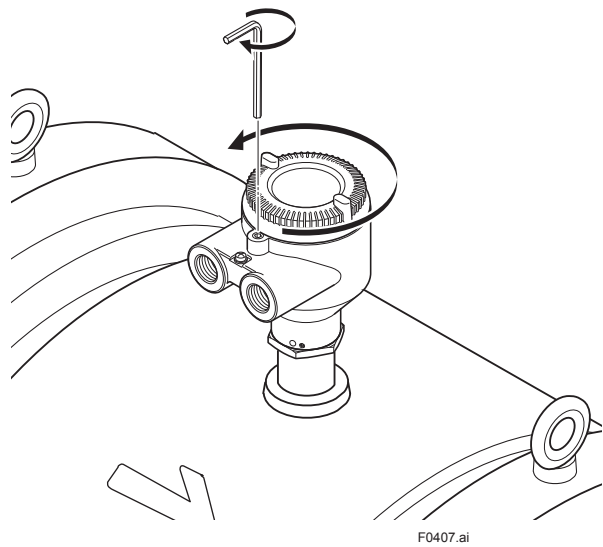

Figure 4.1.7 Removing the Terminal Box Cover

(2) Terminal Configuration

When the cover is removed, the connection terminals will be visible.

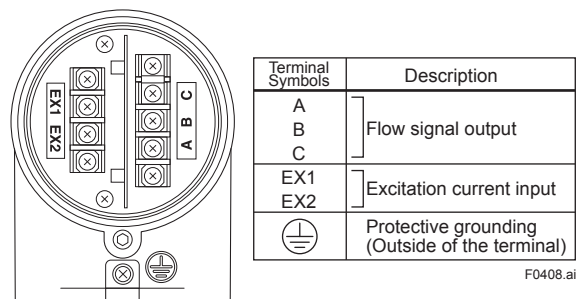

Figure 4.1.8 Terminal Configuration

(3) Wiring the Remote Flowtube with AXFA11 Converters

Connect wiring as shown in the figure below.

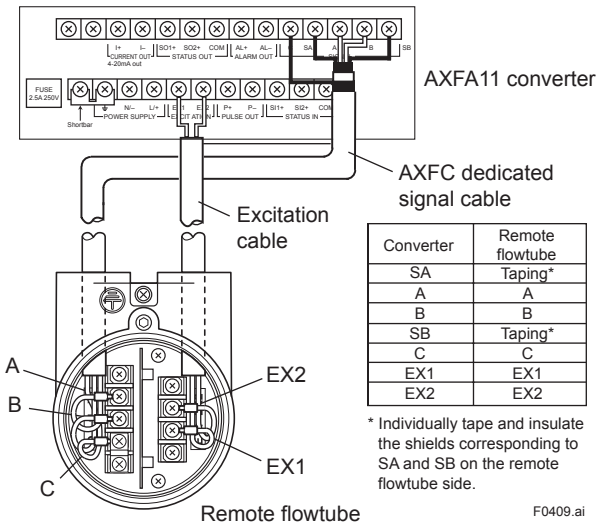

Figure 4.1.9 Wiring Diagram

(4) Grounding

CAUTION

Be sure to connect the protective grounding of the remote flowtube with a cable of 2 mm² or larger cross section in order to avoid electrical shock to the operators and maintenance engineers and to prevent the influence of external noise.

Connect the grounding wire to the ⊕ mark. The grounding should satisfy Class D requirements (ground resistance, 100 Ω or less).

IMPORTANT

Improper grounding can have an adverse affect on the flow measurement. Ensure that the instrument is properly grounded.

The electromotive force of the magnetic flowmeter is minute and it is easy to be affected by noise. And also that reference electric potential is the same as the measuring fluid potential. Therefore, the reference electric potential (terminal potential) of the flowtube and the converter also need to be the same as the measuring fluid. Moreover, that the potential must be the same with ground. Be sure to ground according to Figure 4.1.10. Refer to Figure 3.3.5 or 3.3.6 for wiring to the flanges of remote flowtube when optional grounding rings are not used.

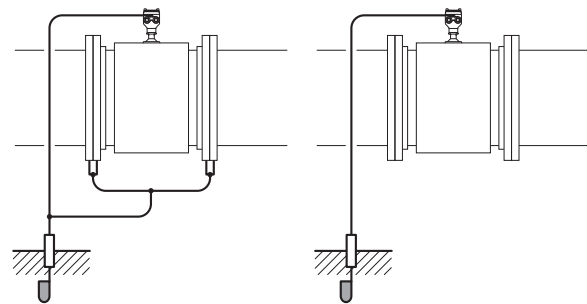
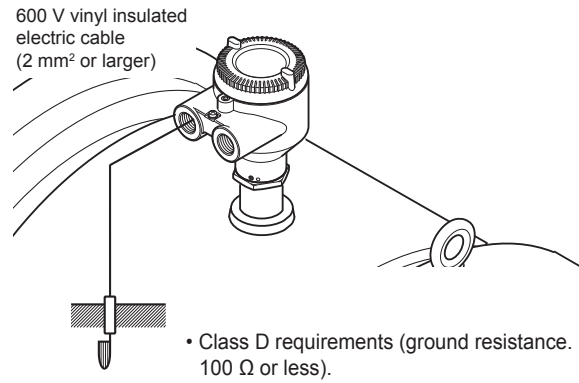

Without optional grounding rings. (Available only for metal piping) With optional grounding rings.

F0410.ai

Figure 4.1.10 Protective Grounding Terminal Location

(5) Installing the Cover

Install the cover to the flowtube by turning it in the direction of the arrow as shown below. Tighten the cover locking screw counterclockwise using a hexagonal wrench (nominal size 3 mm) to lock the cover.

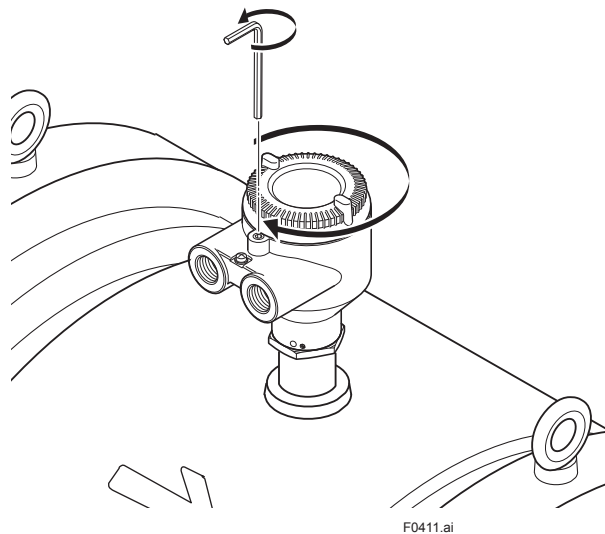

Figure 4.1.11 Installing the Terminal Box Cover

5. MAINTENANCE

WARNING

- Maintenance work must be carried out by the trained personnel having knowledge of safety standard and not by operators.
- When opening the cover, wait for more than 10 minutes after turning off the power. Furthermore, opening of the cover must also be carried out by the trained personnel having knowledge of safety standard.

CAUTION

- When opening the cover, use a hexagonal wrench (nominal size 3 mm).
- Be sure to lock the cover using a hexagonal wrench (nominal size 3 mm) after installing the cover.

5.1 Changing Direction of Electrical Connection

IMPORTANT

The following types can not be changed direction of electrical connection after delivery.

- Submersible Type.
- Optional code DHC (for district heating and cooling or condensation-proof).

- (1) The following tools are required to change the direction of the electrical connection:
 - Hexagonal wrench (nominal size 1.5 mm)
 - Wrench
- (2) Turn off the power to the flowmeter.
- (3) Using the wrench, loosen the hexagonal nut at the neck of the instrument.

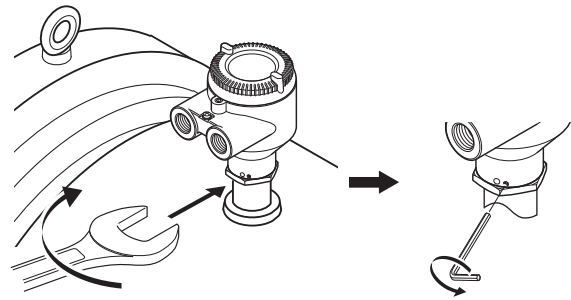

F0501.ai

- (4) Using the hexagonal wrench, loosen the screw in the neck.
- (5) Turn the terminal box in the desired direction.

NOTE

The terminal box can be turned -140 degree to $+180$ degree from the arrow mark indicating the flow direction. Do not exceed these angle.

- (6) Using the hexagonal wrench, retighten the neck screw.

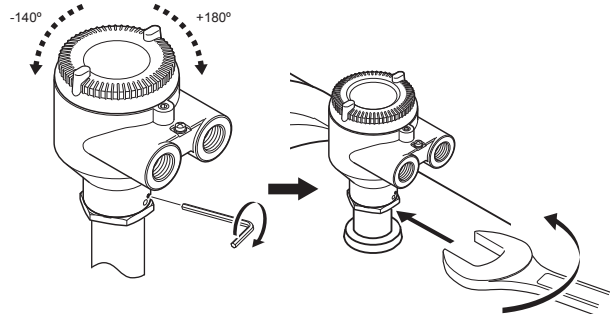

F0502.ai

- (7) Using the wrench, retighten the hexagonal nut at the neck. After that, check that the terminal box is fixed.

5.2 Regular Inspection Items

- (1) **Inspection of moisture-proofing inside the terminal box: Once/year**
- (2) **Retightening of piping joint screws: About twice/year**
- (3) **Inspection of electrodes and lining (in case of adhesive and/or abrasive fluids, etc.)**
Determine the period of regular inspection as necessary.

5.3 Excitation Coil and Insulation Resistance Check



WARNING

- Before checking of the excitation coil and the insulation resistance, be sure that the power supply for AXFA11 converter has been turned off.
- Before checking, be sure to disconnect the cables from the terminals of the remote flowtube.

(1) Excitation Coil Check

Check that there is continuity between terminals EX1 and EX2 in the terminal box. If there is no continuity, the coils may be broken and replacement or repair of the flowtube is necessary. The coil resistance is designed to be 150 Ω or less. If it is not, this may be an abnormal condition. Consult Yokogawa’s sales or service offices.

(2) Insulation Resistance Check

Check the insulation resistances in the terminal box in accordance with the tables below. If any of them falls below the values listed in the tables, consult Yokogawa’s sales or service offices for investigation. If the insulation resistance cannot be restored, replacement or repair of the flowtube is needed. In case of submersible type flowmeters, undo the wiring connection on the converter side and measure resistance at the cable terminals.

Coil Circuit

Checking is possible even if the pipe is filled with fluid.

Test Terminals	Test Voltage	Specification
Between terminals EX1 and C	500 V DC (Use an insulation tester or the equivalent.)	1 MΩ or more

Signal Circuit

Before testing, be sure to empty and dry the interior of the pipe, checking that there is no adhesive material. Also undo the wiring connection on the converter side before testing.

Test Terminals	Test Voltage	Specification
Between terminals A and C Between terminals B and C	500 V DC (Use an insulation tester or the equivalent.)	100 MΩ or more for each

5.4 Troubleshooting

Although magnetic flowmeters rarely require maintenance, failures may occur when the instrument is not operated correctly. This section describes troubleshooting procedures where the cause of the breakdown is identified through receiver indication.

5.4.1 No Indication

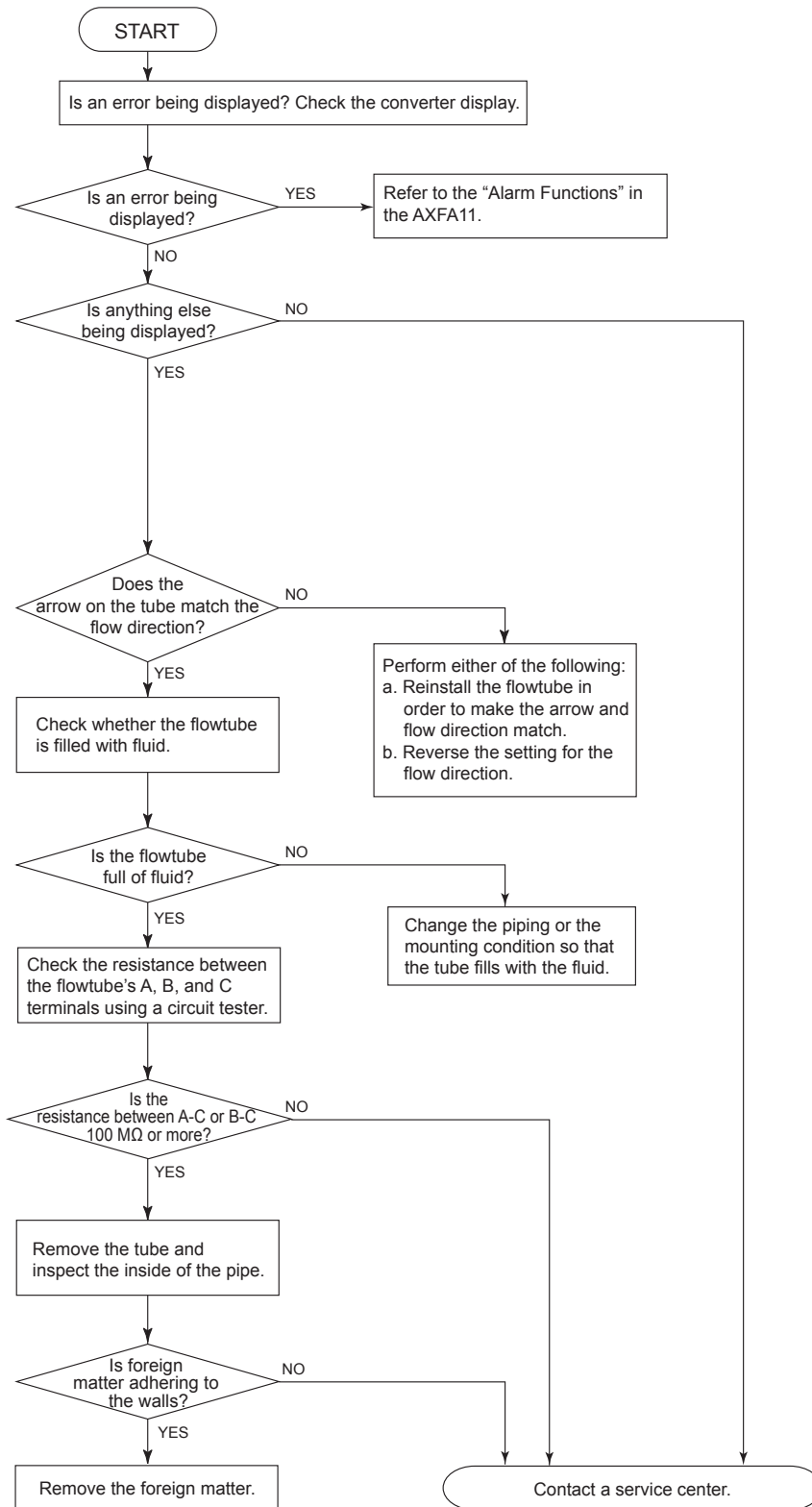

F0503.ai

5.4.2 Unstable Zero

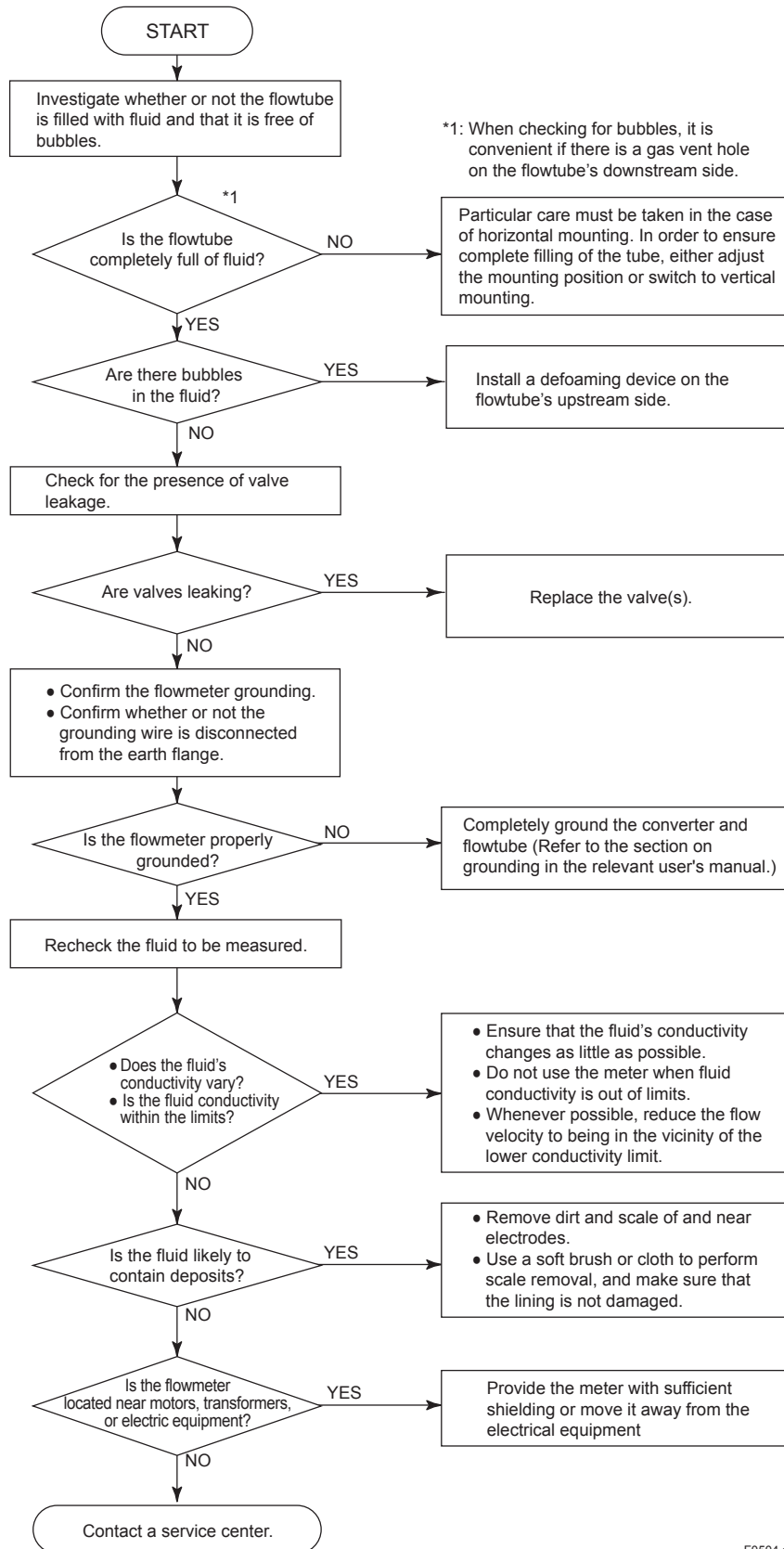

F0504.ai

5.4.3 Disagreement Between Indication and Actual Flow

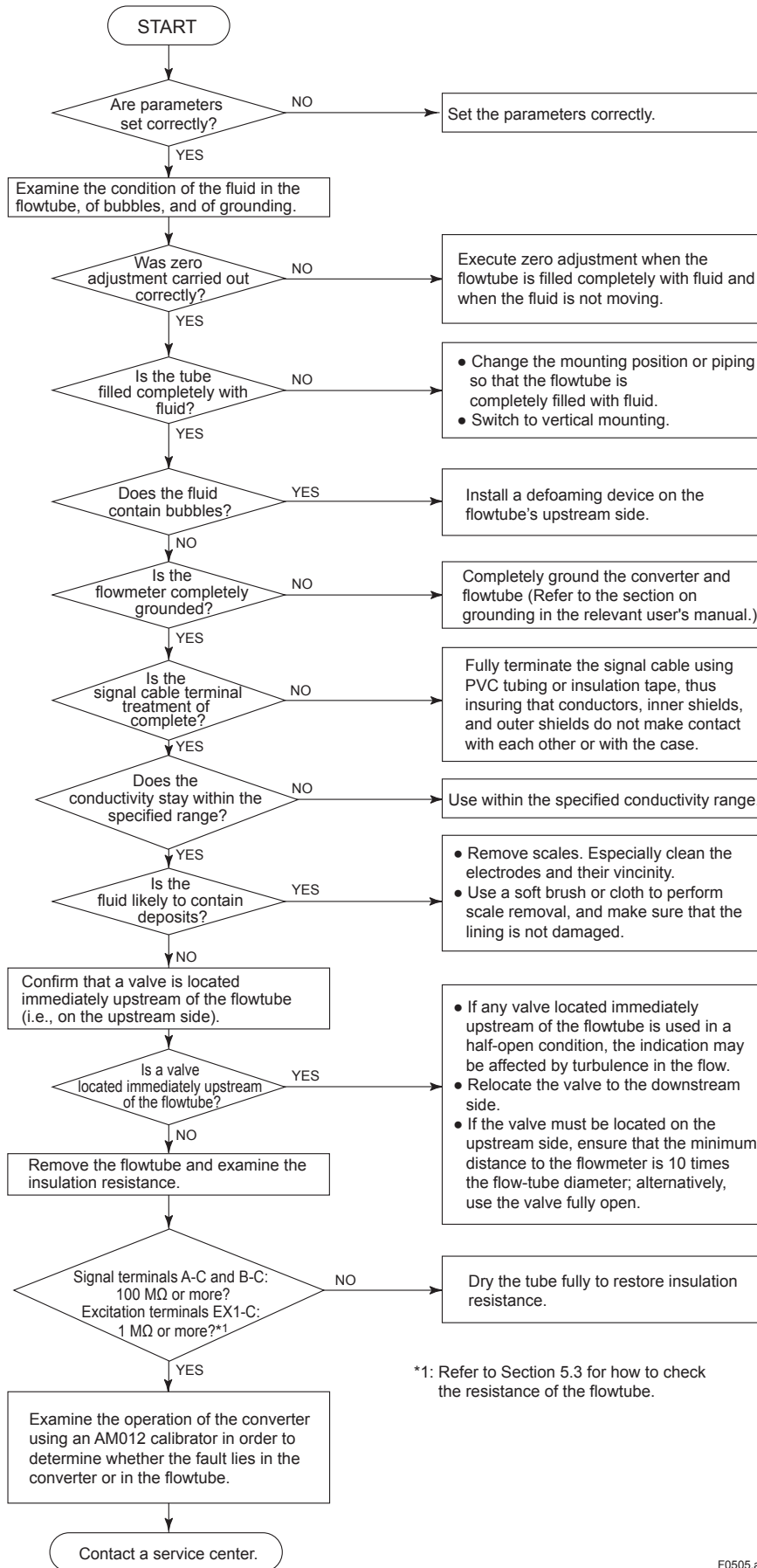

*1: Refer to Section 5.3 for how to check the resistance of the flowtube.

6. OUTLINE

■ STANDARD SPECIFICATIONS

Protection:

General-purpose type: IP66, IP67

Submersible type: IP68 (conforms to continuous immersion under the following test condition)

Test Condition: 50 m below the surface of the water, equivalent to 0.5 MPa hydraulic pressure, for one month. Cable should be protected at customer site.

Material (non-wetted parts):

Flowtube:

Housing: Carbon steel

Flange: Carbon steel

Pipe: Stainless steel

Terminal box: Aluminum alloy

Material (wetted parts):

Lining:

Fluorocarbon PTFE

Natural hard rubber (plus EPDM for sealing)

Natural soft rubber

Polyurethane rubber

Contact Yokogawa office for others.

Electrode:

JIS SUS316L(AISI 316L SS Equivalent)

Hastelloy C276 Equivalent

Grounding ring (option):

JIS SUS304 or SUSF304 (AISI 304 SS Equivalent)

Gasket (for option GR2):

Mixture of SBR and NR

Coating:

General-purpose type:

Pipe, Housing, Flange, Terminal Box:

Corrosion-resistant coating

Coating color: Mint green

Submersible type:

Pipe, Housing, Flange, Terminal Box:

Non-tar epoxy coating (black)

Wiring:

Electrical connection:

ANSI 1/2 NPT female

ISO M20 x 1.5 female

JIS G1/2 (PF1/2) female

Direction of Electrical Connection:

The direction can be changed even after delivery except for submersible type and DHC option type.

Wiring Terminal:

M4 screw

Grounding:

Grounding resistance 100 Ω or less

Combined Converter:

AXFA11 converter

Signal Cable:

AXFC, Maximum cable length to AXFA11 converter up to 200m (660 ft)

■ STANDARD PERFORMANCE

Accuracy (Pulse Output):

0.35% of rate for sizes 500 mm (20 in.) to 1000 mm (40 in.)

0.5% of rate for sizes 1100 mm (44 in.) to 1800 mm (72 in.)

Size mm(in.)	Flow Velocity V m/s (ft/s)	Accuracy
500(20) to 1000(40)	$V < 0.3 (1.0)$	$\pm 2.0\text{mm/s}$
	$0.3 \leq V \leq 10 (1.0) (33)$	$\pm 0.35\%$ of rate $\pm 1.0\text{mm/s}$
1100(44) to 1800(72)	$V < 0.3 (1.0)$	$\pm 3.0\text{mm/s}$
	$0.3 \leq V < 1 (1.0) (3.3)$	$\pm 0.4\%$ of rate $\pm 1.8\text{mm/s}$
	$1 \leq V \leq 10 (3.3) (33)$	$\pm 0.5\%$ of rate $\pm 1.0\text{mm/s}$

For sizes 500mm (20 in.) to 1000mm (40 in.)

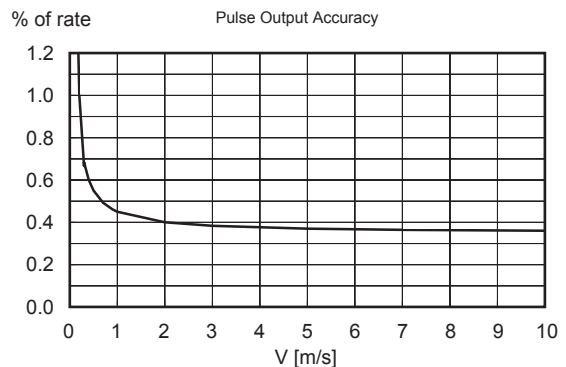

F0601.ai

For sizes 1100mm (44 in.) to 1800mm (72 in.)

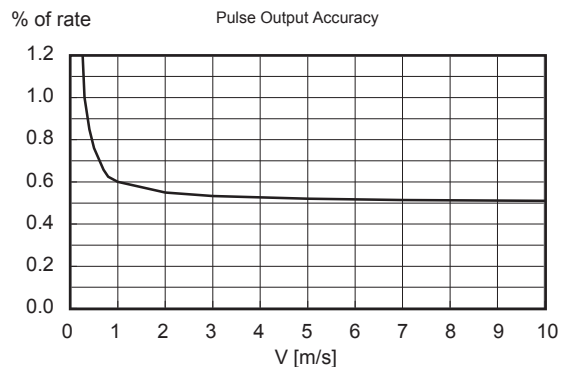

F0602.ai

Note: The accuracy of a product before shipment is defined as totalized value at the result of calibration test in our water actual flow test facility.
 Calibrated conditions in our water actual test facility are as follows:
 Fluid temperature: 20 ± 10°C
 Ambient temperature: 20 ± 5°C
 Length of straight runs:
 10 D or more on the upstream side
 5 D or more on the downstream side
 Reference conditions:
 Similar to BS EN29104, ISO 9104

Accuracy (Current Output):
 Accuracy (Pulse Output) plus ±0.05% of span

Repeatability:
 ±0.2% of rate (V ≥ 1m/s (3.3ft/s))
 ±0.1% of rate ± 1mm/s (V < 1m/s (3.3ft/s))

Maximum Power Consumption:
 Combined with AXFA11: 20W

Insulation Resistance:
 Between excitation current terminal and signal / common terminals : 100MΩ at 500V DC
 Between signal terminals : 100MΩ at 500V DC
 Between signal terminals and common terminal (C) : 100MΩ at 500V DC

 **CAUTION**

- *1: When performing the Insulation Resistance Test, please obey the following caution.
- Following the relevant test, wait for more than 10 seconds after the power supply has been turned off before removing the cover.
 - Remove all wires from terminals before testing.
 - After testing, be sure to discharge by using a resistance and return all wires to its correct position.
 - Screws must be tightened to a torque of 1.18 N-m or more.
 - After closing the cover, the power supply can be restored.

EMC Conformity Standards:  **N200**
 EN61326-1 Class A, Table2 (For use in industrial locations)
 EN61326-2-3
 EN61000-3-2 Class A
 EN61000-3-3

 **CAUTION**

This instrument is a class A product, and it is designed for use in the industrial environment. Please use this instrument in the industrial environment only.

■ NORMAL OPERATING CONDITIONS

Ambient Temperature:
 -10 to +60°C (+14 to +140°F)
 Note: Minimum temperature should also be limited according to minimum fluid temperature of flow tube's specification. Refer to description of "Fluid Temperature and Pressure". Contact Yokogawa office for lower temperature.

Ambient Humidity:
 0 to 100%
 Note: Lengthy continuous operation at 95% or more is not recommended.

Fluid Conductivity:
 20 μS /cm or larger for sizes 1000 mm and below
 50 μS /cm or larger for sizes 1100 mm and above

Measurable Flow Rate Range:

Size mm (in.)	Min. Span 0.1m/s (0.33ft/s)	Max. Span 10m/s (33ft/s)
500 (20)	0 to 70.69 m³/h (0 to 311.3 GPM)	0 to 7,068 m³/h (0 to 31,122 GPM)
600 (24)	0 to 101.79 (0 to 448.2)	0 to 10,178 (0 to 44,815)
700 (28)	0 to 138.55 (0 to 610.0)	0 to 13,854 (0 to 60,999)
800 (32)	0 to 180.96 (0 to 796.8)	0 to 18,095 (0 to 79,672)
900 (36)	0 to 229.03 (0 to 1,009)	0 to 22,902 (0 to 100,835)
1000 (40)	0 to 282.75 (0 to 1,245)	0 to 28,274 (0 to 124,488)

Size mm (in.)	Min. Span 0.3 m/s (1 ft/s)	Max. Span 10 m/s (33 ft/s)
1100 (44)	0 to 1,026.4 m³/h (0 to 4,519 GPM)	0 to 34,211 m³/h (0 to 150,630 GPM)
1200 (48)	0 to 1,221.5 (0 to 5,378)	0 to 40,715 (0 to 179,262)
1350 (54)	0 to 1,545.9 (0 to 6,807)	0 to 51,529 (0 to 226,879)
1400 (56)	0 to 1,662.5 (0 to 7,320)	0 to 55,418 (0 to 243,997)
1500 (60)	0 to 1,908.6 (0 to 8,403)	0 to 63,617 (0 to 280,098)
1600 (64)	0 to 2,171.5 (0 to 9,561)	0 to 72,382 (0 to 318,689)
1800 (72)	0 to 2,748.3 (0 to 12,101)	0 to 91,608 (0 to 403,341)

Fluid Temperature and Pressure:
 Note: The following values show maximum allowable fluid pressure for the flowtube. Further fluid pressure should also be limited according to flange rating.

Lining Material	Fluid Temperature	Fluid Pressure
Fluorocarbon PTFE	-10 to 120°C (14 to 248°F)	0 to 1 MPa (0 to 145 psi)
Natural hard rubber	-5 to 80°C (23 to 175°F)	0 to 1 MPa (0 to 145 psi)
Natural soft rubber	-10 to 70°C (14 to 158°F)	0 to 1 MPa (0 to 145 psi)
Polyurethane rubber	-10 to 40°C (14 to 104°F)	-0.1 to 1 MPa (-14.5 to 145 psi)

■ MODEL AND SUFFIX CODE

● For Process Connections other than JIS F12 (JIS 75M)

Model	Suffix Code	Description	Available Size / Model
AXW500		Size 500 mm (20 in.) Remote Flowtube	
AXW600		Size 600 mm (24 in.) Remote Flowtube	
AXW700		Size 700 mm (28 in.) Remote Flowtube	
AXW800		Size 800 mm (32 in.) Remote Flowtube	
AXW900		Size 900 mm (36 in.) Remote Flowtube	
AXW10L		Size 1000 mm (40 in.) Remote Flowtube	
AXW12L		Size 1200 mm (48 in.) Remote Flowtube	
AXW14L		Size 1400 mm (56 in.) Remote Flowtube	
AXW16L		Size 1600 mm (64 in.) Remote Flowtube	
AXW18L		Size 1800 mm (72 in.) Remote Flowtube	
Use	G	General-purpose type	
	W	Submersible type	
Converter	-N	Remote Flowtube for Combined Use with AXFA11	
Power Supply	N	Remote Flowtube	
Lining (*1)	F	Fluorocarbon PTFE	See "Proces Connection".
	H	Natural Hard Rubber	See "Proces Connection".
	D	Natural Soft Rubber	See "Proces Connection".
	U	Polyurethane Rubber	See "Proces Connection".
Electrode Material (*1)	L	JIS SUS316L (AISI 316L SS Equivalent)	
	H	Hastelloy C276 Equivalent	
Electrode Structure	1	Non-replaceable	
Grounding Structure (*2)	N	None (*3), available as optional feature (GR1)	
Process Connection (*4)	-CA1	ASME B16.5 Class 150 Flange (Carbon Steel)	500 mm (20 in.) and 600 mm (24 in.) for lining code F/H/D/U
		ASME B16.47 Series A Class 150 Flange (Carbon Steel)	700 mm (28 in.) to 1000 mm (40 in.) for lining code F/H/D/U
	-CB1	AWWA C207 Class D (Carbon Steel)	700 mm (28 in.) to 1000 mm (40 in.) for lining code F/H/D/U 1200 mm (48 in.) for lining code H
	-CEJ	EN1092-1 PN6 Flange (Carbon Steel)	1200 mm (48 in.) to 1800 mm (72 in.) for lining code H
	-CEK	EN1092-1 PN10 Flange (Carbon Steel) (fluid pressure up to 0.6 MPa)	
	-CE1	EN1092-1 PN10 Flange (Carbon Steel) (fluid pressure up to 1 MPa)	500 mm (20 in.) to 1000 mm (40 in.) for lining code F/H/D/U 1200 mm (48 in.) to 1800 mm (72 in.) for lining code H
	-CE2	EN1092-1 PN16 Flange (Carbon Steel) (fluid pressure up to 1 MPa)	500 mm (20 in.) to 1000 mm (40 in.) for lining code F/H/D/U
	-CJ1	JIS B2220 10K Flange (Carbon Steel)	
	-CS1	AS2129 Table D (Carbon Steel)	500 mm (20 in.) to 1000 mm (40 in.) for lining code F/H/D/U
	-CS2	AS2129 Table E (Carbon Steel)	
-CT1	AS4087 PN16 (Carbon Steel)		
Lay Length	N	Standard	
Electrical Connection	-0	JIS G1/2 female	
	-2	ANSI 1/2 NPT female	Not available for Submersible type
	-4	ISO M20 x 1.5 female	Not available for Submersible type
Indicator	N	None	
Calibration	B	Standard	
Optional Specifications	/□	Optional code	

- *1: ⚠ Users must consider the characteristics of selected wetted parts material and influence of process fluids. The use of inappropriate materials can result in the leakage of corrosive process fluids and cause injury to personnel and/or damage to plant facilities. It is also possible that the instrument itself can be damaged and that fragments from the instrument can contaminate the user's process fluids.
Be very careful with highly corrosive process fluids such as hydrochloric acid, sulfuric acid, hydrogen sulfide, sodium hypochlorite, and high-temperature steam (150°C [302°F] or above). Contact Yokogawa for detailed information of the wetted parts material.
- *2: Select optional grounding rings (code GR1) if necessary. For example, grounding rings are necessary for plastic piping.
- *3: "None" is applicable only for metal piping and wiring for grounding will be necessary so that the electric potentials between flowtube and piping flange should be the same.
- *4: Contact Yokogawa office for ISO flange connection.

● For Process Connection JIS F12 (JIS 75M)

Model	Suffix Code	Description	Available Size / Model
AXW500		Size 500 mm (20 in.) Remote Flowtube	
AXW600		Size 600 mm (24 in.) Remote Flowtube	
AXW700		Size 700 mm (28 in.) Remote Flowtube	
AXW800		Size 800 mm (32 in.) Remote Flowtube	
AXW900		Size 900 mm (36 in.) Remote Flowtube	
AXW10L		Size 1000 mm (40 in.) Remote Flowtube	
AXW11L		Size 1100 mm (44 in.) Remote Flowtube	
AXW12L		Size 1200 mm (48 in.) Remote Flowtube	
AXW13L		Size 1350 mm (54 in.) Remote Flowtube	
AXW15L		Size 1500 mm (60 in.) Remote Flowtube	
AXW16L		Size 1600 mm (64 in.) Remote Flowtube	
AXW18L		Size 1800 mm (72 in.) Remote Flowtube	
Use	G	General-purpose type	
	W	Submersible type	
Converter	-N	Remote Flowtube for Combined Use with AXFA11	
Power Supply	N	Remote Flowtube	
Lining (*1)	U	Polyurethane Rubber	
Electrode Material (*1)	L	JIS SUS316L (AISI 316L SS Equivalent)	
	H	Hastelloy C276 Equivalent	
Electrode Structure	1	Non-replaceable	
Grounding Structure (*2)	N	None (*3), available as optional feature (GR1 or GR2)	
Process Connection	-CG1	JIS F12 (JIS 75M) Flange (Carbon Steel)	
Lay Length	N	Standard	
Electrical Connection	-0	JIS G1/2 female	
	-2	ANSI 1/2 NPT female	Not available for Submersible type
	-4	ISO M20 x 1.5 female	Not available for Submersible type
Indicator	N	None	
Calibration	B	Standard	
Optional Specifications	/□	Optional code	

- *1: ⚠ Users must consider the characteristics of selected wetted parts material and influence of process fluids. The use of inappropriate materials can result in the leakage of corrosive process fluids and cause injury to personnel and/or damage to plant facilities. It is also possible that the instrument itself can be damaged and that fragments from the instrument can contaminate the user's process fluids. Be very careful with highly corrosive process fluids such as hydrochloric acid, sulfuric acid, hydrogen sulfide, sodium hypochlorite, and high-temperature steam (150°C [302°F] or above). Contact Yokogawa for detailed information of the wetted parts material.
- *2: Select optional grounding rings (code GR1 or GR2) if necessary. For example, grounding rings are necessary for plastic piping. The code GR1 is optional only for sizes 500 mm (20 in.) to 1000 mm (40 in.). The code GR2 is optional only for sizes 1100 mm (44 in.) to 1800 mm (72 in.).
- *3: "None" is applicable only for metal piping and wiring for grounding will be necessary so that the electric potentials between flowtube and piping flange should be the same.

■ **OPTIONAL SPECIFICATIONS**

○ : Available – : Not available

Item	Specifications	Applicable Model		Code
		General	Submersible	
		AXW***G	AXW***W	
Grounding Rings (*1)	JIS SUS304 (AISI 304 SS Equivalent), a set of two rings	○	○	GR1
Grounding Rings (*2)	SUSF304 (AISI 304 SS Equivalent), a set of two rings with gaskets "B".	○	○	GR2
For District Heating and Cooling or Condensation-proof	Urethane resin potting is applied in the terminal box of a remote flowtube. Select JIS G1/2 for the electrical connections. 30-meter dedicated signal and excitation cables are pre-wired and waterproof glands with union joints are attached at factory.	○	–	DHC
User-specified Signal and Excitation Cable Length	Available for the submersible type and a model with optional code DHC. The cable length is limited up to 200 meters combined with an AXFA11 converter. Following "L," specify the cable length in three digits as a multiple of 1 meter (e. g., 001, 002, or 005) for a length up to 5 meters, or as a multiple of 5 meters (i.e., 005, 010, 015, or the like) for a length of 5 meters or more. If this optional code is not selected, a 30-meter length cable is attached.	○	○	L***
Mass Unit Setting	The flow rate span, transmission pulse weight, and totalizer display pulse weight can be set in terms of mass unit. Specify the density of the process fluid when ordering in addition to the mass flow rate span, transmission pulse weight (for mass unit), and totalizer display pulse weight (for mass unit). When ordering a remote flowtube, parameters for 'Mass Unit Setting' will be set in the corresponding converter before shipment. 1. Density a. Available density Numerics: Specify the numeric within the value of 500 to 2000 kg/m ³ , 4.2 to 16.7 lb/gal, or 31.2 to 124.8 lb/cf. And it can be up to five digits, to a maximum of 32000 ignoring the decimal point. A fraction is limited to the fourth decimal place. b. Available density units: kg/m ³ , lb/gal, lb/cf Example: A water density is about 1000 kg/m ³ . In this case specify "1000kg/m ³ ". However a density is changed by temperature. Specify the actual density. (The 1000 kg/m ³ is equivalent to 8.345lb/gal and 62.43lb/cf.) 2. The mass flow rate span, transmission pulse weight, and totalizer display pulse weight a. Available density Numerics: Specify the numeric within the value of 0.0001 to 32000. And it can be up to five digits, to a maximum of 32000 ignoring the decimal point. A fraction is limited to the fourth decimal place. b. Mass Units Available mass units: t, kg, g, klb, lb Available time units: /d, /h, /min, /s Note1: In case of specifying the mass flow span, calculate the volumetric flow span by the setting density, and specify the available value in the mass flow span. Note2: In case of transmission pulse weight and totalizer display pulse weight, specify the mass unit which was specified as the flow unit.	○	○	MU
G3/4 Female Waterproof Glands	Waterproof glands for G3/4 conduits or flexible tubes are attached to the electrical connections. Available only for JIS G1/2 electric connections.	○	–	EW
Waterproof Glands	Waterproof glands are attached to the electrical connections. Available only for JIS G1/2 electric connections.	○	–	EG
Waterproof Glands with Union Joints	Waterproof glands with union joints are attached to the electrical connections. Available only for JIS G1/2 electric connections.	○	–	EU
Stainless Steel Tag Plate	A pendant tag plate of stainless steel (AISI 304 SS equivalent) is provided in addition to the standard nameplate with the tag number inscribed on it. Dimension (Height x Width): Approx. 12.5 (4.92) x 40 (15.7) mm (inch)	○	○	SCT
Direction Change of Electrical Connection (*3)	+90 degrees rotated terminal box to change the direction of the electrical connection.	○	○	RA
	+180 degrees rotated terminal box to change the direction of the electrical connection.	○	○	RB
	–90 degrees rotated terminal box to change the direction of the electrical connection.	○	○	RC
Material Certificate	Material certificates are provided for pipe, electrodes, flanges, and also optional grounding rings when specified.	○	○	M01

*1: This is not available for models with process connection JIS F12 (JIS 75M) of sizes 1100 mm (44 in.) to 1800 mm (72 in.). Refer to the section on "Mounting Procedures" on necessary gaskets.

*2: This is available only for models with process connection JIS F12 (JIS 75M) of sizes 1100 mm (44 in.) to 1800 mm (72 in.). Refer to the section on "Mounting Procedures" on necessary gaskets.

*3: Refer to the image below.

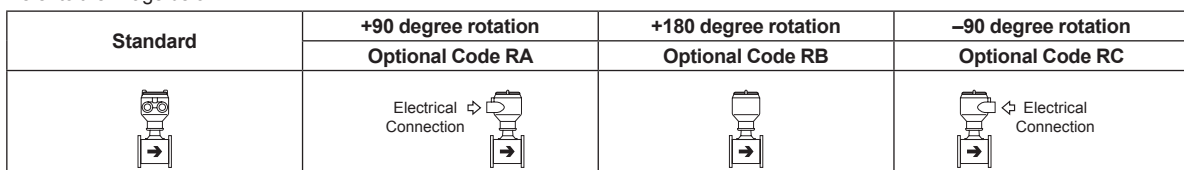

■ DIMENSIONAL DRAWINGS

● AXW500 to AXW10L, Sizes 500 mm (20 in.) to 1000 mm (40 in.)

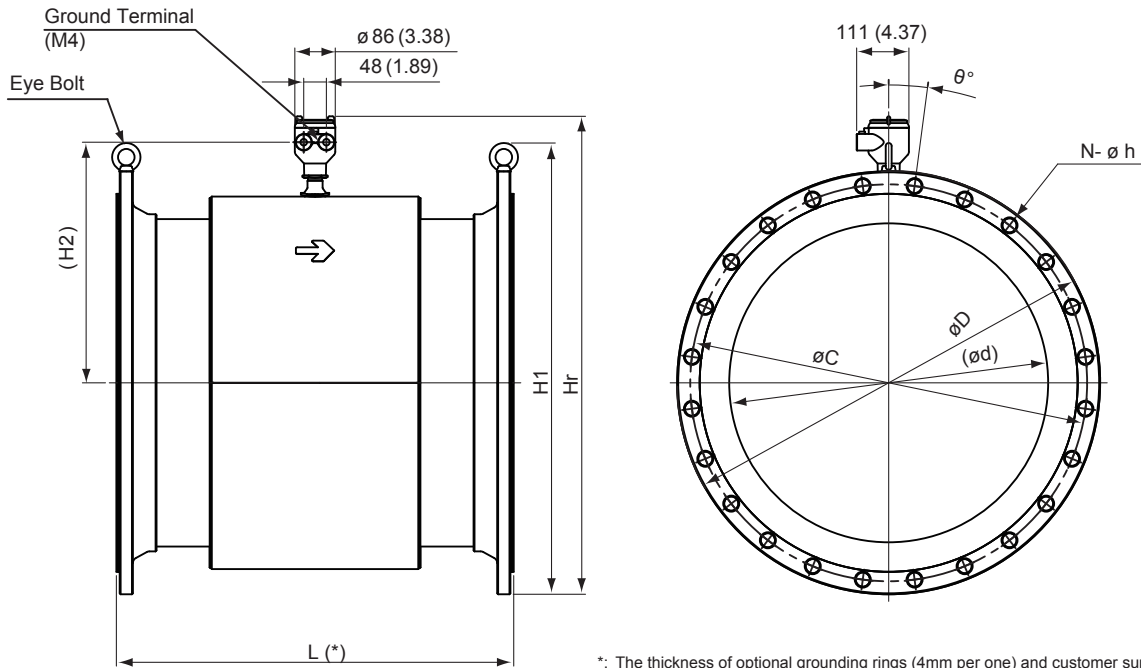

*: The thickness of optional grounding rings (4mm per one) and customer supplied gaskets are not included in "L" here.

F0603.ai

(1) ASME Flange Type

Unit: mm (approx. in.)

Process Connection Code	CA1						
Flange Type	ASME B16.5 Class150		ASME B16.47 Class150				
Size Code	500	600	700	800	900	10L	
Size	500 (20)	600 (24)	700 (28)	800 (32)	900 (36)	1000 (40)	
Lining Code	H, F, U, D						
Lay Length L	600 (23.62)	720 (28.35)	840 (33.07)	960 (37.80)	1080 (42.52)	1200 (47.24)	
Flange Outer Diameter øD	700 (27.56)	815 (32.09)	927 (36.50)	1060 (41.75)	1168 (46.00)	1289 (50.75)	
Bolt Circle Diameter øC	635 (25.00)	749.3 (29.50)	863.6 (34.00)	977.9 (38.50)	1086 (42.75)	1200 (47.25)	
Inner Diameter ød	Lining H, F, D	477 (18.78)	578 (22.76)	675 (26.57)	777 (30.59)	878 (34.57)	976 (38.43)
	Lining U	469 (18.46)	570 (22.44)	667 (26.26)	769 (30.28)	870 (34.25)	968 (38.11)
Bolt Hole Pitch Half Angle θ	9°	9°	6.4°	6.4°	5.6°	5°	
Bolt Hole Diameter øh	31.8 (1.25)	34.9 (1.37)	35.1 (1.38)	41.1 (1.62)	41.1 (1.62)	41.1 (1.62)	
Number of Bolt Holes N	20	20	28	28	32	36	
Height H1	760 (29.92)	875 (34.45)	998 (39.29)	1150 (45.28)	1278 (50.31)	1399 (55.08)	
Height H2	408 (16.06)	459 (18.07)	509 (20.04)	560 (22.05)	611 (24.06)	662 (26.06)	
Height Hr	812 (31.97)	921 (36.26)	1027 (40.43)	1144 (45.04)	1249 (49.17)	1361 (53.58)	
Inner Diameter of Eye Bolt	35 (1.38)	35 (1.38)	40 (1.57)	50 (1.97)	60 (2.36)	60 (2.36)	
Approx. Weight, Unit: kg (lb)	212 (467)	305 (672)	479 (1056)	680 (1499)	882 (1944)	1125 (2480)	

Note: When submersible type or option code DHC is selected, waterproof glands and a 30-meter length cable are attached. Add 9.5 kg (20.9 lb) to the weight in the table.

(2) AWWA Flange Type

Unit: mm (approx. in.)

Process Connection Code	CB1				
Flange Type	AWWA C207 Class D				
Size Code	700	800	900	10L	
Size	700 (28)	800 (32)	900 (36)	1000 (40)	
Lining Code	H, F, U, D				
Lay Length L	840 (33.07)	960 (37.80)	1080 (42.52)	1200 (47.24)	
Flange Outer Diameter øD	927 (36.50)	1060 (41.75)	1168 (46.00)	1289 (50.75)	
Bolt Circle Diameter øC	863.6 (34.00)	977.9 (38.50)	1086 (42.75)	1200 (47.25)	
Inner Diameter ød	Lining H, F, D	675 (26.57)	777 (30.59)	878 (34.57)	976 (38.43)
	Lining U	667 (26.26)	769 (30.28)	870 (34.25)	968 (38.11)
Bolt Hole Pitch Half Angle θ	6.4°	6.4°	5.6°	5°	
Bolt Hole Diameter øh	34.9 (1.375)	41.3 (1.625)	41.3 (1.625)	41.3 (1.625)	
Number of Bolt Holes N	28	28	32	36	
Height H1	987 (38.86)	1131 (44.53)	1239 (48.78)	1379 (54.29)	
Height H2	509 (20.04)	560 (22.05)	611 (24.06)	662 (26.06)	
Height Hr	1027 (40.43)	1144 (45.04)	1249 (49.17)	1361 (53.58)	
Inner Diameter of Eye Bolt	35 (1.38)	40 (1.57)	40 (1.57)	50 (1.97)	
Approx. Weight, Unit: kg (lb)	288 (635)	387 (853)	485 (1069)	659 (1453)	

Note: When submersible type or option code DHC is selected, waterproof glands and a 30-meter length cable are attached. Add 9.5 kg (20.9 lb) to the weight in the table.

(3) EN PN10 Flange Type

Unit: mm (approx. in.)

Process Connection Code	CE1						
Flange Type	EN1092-1 PN10						
Size Code	500	600	700	800	900	10L	
Size	500 (20)	600 (24)	700 (28)	800 (32)	900 (36)	1000 (40)	
Lining Code	H, F, U, D						
Lay Length L	600 (23.62)	720 (28.35)	840 (33.07)	960 (37.80)	1080 (42.52)	1200 (47.24)	
Flange Outer Diameter øD	670 (26.38)	780 (30.71)	895 (35.24)	1015 (39.96)	1115 (43.90)	1230 (48.43)	
Bolt Circle Diameter øC	620 (24.41)	725 (28.54)	840 (33.07)	950 (37.40)	1050 (41.34)	1160 (45.67)	
Inner Diameter ød	Lining H, F, D	477 (18.78)	578 (22.76)	675 (26.57)	777 (30.59)	878 (34.57)	976 (38.43)
	Lining U	469 (18.46)	570 (22.44)	667 (26.26)	769 (30.28)	870 (34.25)	968 (38.11)
Bolt Hole Pitch Half Angle θ	9°	9°	7.5°	7.5°	6.4°	6.4°	
Bolt Hole Diameter øh	26 (1.02)	30 (1.18)	30 (1.18)	33 (1.30)	33 (1.30)	36 (1.42)	
Number of Bolt Holes N	20	20	24	24	28	28	
Height H1	730 (28.74)	840 (33.07)	955 (37.60)	1086 (42.76)	1186 (46.69)	1320 (51.97)	
Height H2	408 (16.06)	459 (18.07)	509 (20.04)	560 (22.05)	611 (24.06)	662 (26.06)	
Height Hr	797 (31.38)	903 (35.51)	1011 (39.80)	1122 (44.17)	1223 (48.15)	1331 (52.40)	
Inner Diameter of Eye Bolt	35 (1.38)	35 (1.38)	35 (1.38)	40 (1.57)	40 (1.57)	50 (1.97)	
Approx. Weight, Unit: kg (lb)	170 (375)	232 (511)	285 (628)	380 (838)	491 (1082)	646 (1424)	

Note: When submersible type or option code DHC is selected, waterproof glands and a 30-meter length cable are attached. Add 9.5 kg (20.9 lb) to the weight in the table.

(4) EN PN16 Flange Type (fluid pressure up to 1 MPa)

Unit: mm (approx. in.)

Process Connection Code		CE2					
Flange Type		EN1092-1 PN16					
Size Code		500	600	700	800	900	10L
Size		500 (20)	600 (24)	700 (28)	800 (32)	900 (36)	1000 (40)
Lining Code		H, F, U, D					
Lay Length L		600 (23.62)	720 (28.35)	840 (33.07)	960 (37.80)	1080 (42.52)	1200 (47.24)
Flange Outer Diameter øD		715 (28.15)	840 (33.07)	910 (35.83)	1025 (40.35)	1125 (44.29)	1255 (49.41)
Bolt Circle Diameter øC		650 (25.59)	770 (30.31)	840 (33.07)	950 (37.40)	1050 (41.34)	1170 (46.06)
Inner Diameter ød	Lining H, F, D	477 (18.78)	578 (22.76)	675 (26.57)	777 (30.59)	878 (34.57)	976 (38.43)
	Lining U	469 (18.46)	570 (22.44)	667 (26.26)	769 (30.28)	870 (34.25)	968 (38.11)
Bolt Hole Pitch Half Angle θ		9°	9°	7.5°	7.5°	6.4°	6.4°
Bolt Hole Diameter øh		33 (1.30)	36 (1.42)	36 (1.42)	39 (1.54)	39 (1.54)	42 (1.65)
Number of Bolt Holes N		20	20	24	24	28	28
Height H1		775 (30.51)	900 (35.43)	970 (38.19)	1096 (43.15)	1196 (47.09)	1345 (52.95)
Height H2		408 (16.06)	459 (18.07)	509 (20.04)	560 (22.05)	611 (24.06)	662 (26.06)
Height Hr		820 (32.28)	933 (36.73)	1018 (40.08)	1127 (44.37)	1228 (48.37)	1344 (52.91)
Inner Diameter of Eye Bolt		35 (1.38)	35 (1.38)	35 (1.38)	40 (1.57)	40 (1.57)	50 (1.97)
Approx. Weight, Unit: kg (lb)		230 (507)	350 (772)	330 (728)	427 (941)	535 (1179)	742 (1636)

Note: When submersible type or option code DHC is selected, waterproof glands and a 30-meter length cable are attached. Add 9.5 kg (20.9 lb) to the weight in the table.

(5) JIS 10K Flange Type

Unit: mm (approx. in.)

Process Connection Code		CJ1					
Flange Type		JIS B2220 10K					
Size Code		500	600	700	800	900	10L
Size		500 (20)	600 (24)	700 (28)	800 (32)	900 (36)	1000 (40)
Lining Code		H, F, U, D					
Lay Length L		600 (23.62)	720 (28.35)	840 (33.07)	960 (37.80)	1080 (42.52)	1200 (47.24)
Flange Outer Diameter øD		675 (26.57)	795 (31.30)	905 (35.63)	1020 (40.16)	1120 (44.09)	1235 (48.62)
Bolt Circle Diameter øC		620 (24.41)	730 (28.74)	840 (33.07)	950 (37.40)	1050 (41.34)	1160 (45.67)
Inner Diameter ød	Lining H, F, D	477 (18.78)	578 (22.76)	675 (26.57)	777 (30.59)	878 (34.57)	976 (38.43)
	Lining U	469 (18.46)	570 (22.44)	667 (26.26)	769 (30.28)	870 (34.25)	968 (38.11)
Bolt Hole Pitch Half Angle θ		9°	9°	7.5°	6.4°	6.4°	6.4°
Bolt Hole Diameter øh		27 (1.06)	33 (1.30)	33 (1.30)	33 (1.30)	33 (1.30)	39 (1.54)
Number of Bolt Holes N		20	20	24	28	28	28
Height H1		735 (28.94)	855 (33.66)	965 (37.99)	1091 (42.95)	1191 (46.89)	1325 (52.17)
Height H2		408 (16.06)	459 (18.07)	509 (20.04)	560 (22.05)	611 (24.06)	662 (26.06)
Height Hr		800 (31.50)	911 (35.87)	1016 (40.00)	1124 (44.25)	1225 (48.23)	1334 (52.2)
Inner Diameter of Eye Bolt		35 (1.38)	35 (1.38)	35 (1.38)	40 (1.57)	40 (1.57)	50 (1.97)
Approx. Weight, Unit: kg (lb)		156 (344)	223 (492)	310 (683)	408 (899)	522 (1151)	689 (1519)

Note: When submersible type or option code DHC is selected, waterproof glands and a 30-meter length cable are attached. Add 9.5 kg (20.9 lb) to the weight in the table.

(6) AS2129 Table D Flange Type

Unit: mm (approx. in.)

Process Connection Code		CS1					
Flange Type		AS2129 Table D					
Size Code		500	600	700	800	900	10L
Size		500 (20)	600 (24)	700 (28)	800 (32)	900 (36)	1000 (40)
Lining Code		H, F, U, D					
Lay Length L		600 (23.62)	720 (28.35)	840 (33.07)	960 (37.80)	1080 (42.52)	1200 (47.24)
Flange Outer Diameter øD		705 (27.76)	825 (32.48)	910 (35.83)	1060 (41.73)	1175 (46.26)	1255 (49.41)
Bolt Circle Diameter øC		641 (25.24)	756 (29.76)	845 (33.27)	984 (38.74)	1092 (42.99)	1175 (46.26)
Inner Diameter ød	Lining H, F, D	477 (18.78)	578 (22.76)	675 (26.57)	777 (30.59)	878 (34.57)	976 (38.43)
	Lining U	469 (18.46)	570 (22.44)	667 (26.26)	769 (30.28)	870 (34.25)	968 (38.11)
Bolt Hole Pitch Half Angle θ		11.3°	11.3°	9°	9°	7.5°	7.5°
Bolt Hole Diameter øh		26 (1.02)	30 (1.18)	30 (1.18)	36 (1.42)	36 (1.42)	36 (1.42)
Number of Bolt Holes N		16	16	20	20	24	24
Height H1		765 (30.12)	885 (34.84)	970 (38.19)	1131 (44.53)	1265 (49.80)	1345 (52.95)
Height H2		408 (16.06)	459 (18.07)	509 (20.04)	560 (22.05)	611 (24.06)	662 (26.06)
Height Hr		815 (32.09)	926 (36.46)	1018 (40.08)	1144 (45.04)	1253 (49.33)	1344 (52.91)
Inner Diameter of Eye Bolt		35 (1.38)	35 (1.38)	35 (1.38)	40 (1.57)	50 (1.97)	50 (1.97)
Approx. Weight, Unit: kg (lb)		157 (346)	225 (496)	290 (639)	433 (977)	594 (1310)	728 (1605)

Note: When submersible type or option code DHC is selected, waterproof glands and a 30-meter length cable are attached. Add 9.5 kg (20.9 lb) to the weight in the table.

(7) AS2129 Table E Flange Type

Unit: mm (approx. in.)

Process Connection Code		CS2					
Flange Type		AS2129 Table E					
Size Code		500	600	700	800	900	10L
Size		500 (20)	600 (24)	700 (28)	800 (32)	900 (36)	1000 (40)
Lining Code		H, F, U, D					
Lay Length L		600 (23.62)	720 (28.35)	840 (33.07)	960 (37.80)	1080 (42.52)	1200 (47.24)
Flange Outer Diameter øD		705 (27.76)	825 (32.48)	910 (35.83)	1060 (41.73)	1175 (46.26)	1255 (49.41)
Bolt Circle Diameter øC		641 (25.24)	756 (29.76)	845 (33.27)	984 (38.74)	1092 (42.99)	1175 (45.67)
Inner Diameter ød	Lining H, F, D	477 (18.78)	578 (22.76)	675 (26.57)	777 (30.59)	878 (34.57)	976 (38.43)
	Lining U	469 (18.46)	570 (22.44)	667 (26.26)	769 (30.28)	870 (34.25)	968 (38.11)
Bolt Hole Pitch Half Angle θ		11.3°	11.3°	9°	9°	7.5°	7.5°
Bolt Hole Diameter øh		26 (1.02)	33 (1.30)	33 (1.30)	36 (1.42)	36 (1.42)	39 (1.54)
Number of Bolt Holes N		16	16	20	20	24	24
Height H1		765 (30.12)	885 (34.84)	970 (38.19)	1131 (44.53)	1265 (49.80)	1345 (52.95)
Height H2		408 (16.06)	459 (18.07)	509 (20.04)	560 (22.05)	611 (24.06)	662 (26.06)
Height Hr		815 (32.09)	926 (36.46)	1018 (40.08)	1144 (45.04)	1253 (49.33)	1344 (52.91)
Inner Diameter of Eye Bolt		35 (1.38)	35 (1.38)	35 (1.38)	40 (1.57)	50 (1.97)	50 (1.97)
Approx. Weight, Unit: kg (lb)		184 (406)	288 (635)	354 (780)	508 (1120)	703 (1550)	832 (1834)

Note: When submersible type or option code DHC is selected, waterproof glands and a 30-meter length cable are attached. Add 9.5 kg (20.9 lb) to the weight in the table.

(8) AS4087 PN16 Flange Type

Unit: mm (approx. in.)

Process Connection Code		CT1					
Flange Type		AS4087 PN16					
Size Code		500	600	700	800	900	10L
Size		500 (20)	600 (24)	700 (28)	800 (32)	900 (36)	1000 (40)
Lining Code		H, F, U, D					
Lay Length L		600 (23.62)	720 (28.35)	840 (33.07)	960 (37.80)	1080 (42.52)	1200 (47.24)
Flange Outer Diameter ϕ D		705 (27.76)	825 (32.48)	910 (35.83)	1060 (41.73)	1175 (46.26)	1255 (49.41)
Bolt Circle Diameter ϕ C		641 (25.24)	756 (29.76)	845 (33.27)	984 (38.74)	1092 (42.99)	1175 (45.67)
Inner Diameter ϕ d	Lining H, F, D	477 (18.78)	578 (22.76)	675 (26.57)	777 (30.59)	878 (34.57)	976 (38.43)
	Lining U	469 (18.46)	570 (22.44)	667 (26.26)	769 (30.28)	870 (34.25)	968 (38.11)
Bolt Hole Pitch Half Angle θ		11.3°	11.3°	9°	9°	7.5°	7.5°
Bolt Hole Diameter ϕ h		26 (1.02)	30 (1.18)	30 (1.18)	36 (1.42)	36 (1.42)	36 (1.42)
Number of Bolt Holes N		16	16	20	20	24	24
Height H1		765 (30.12)	885 (34.84)	970 (38.19)	1131 (44.53)	1265 (49.80)	1345 (52.95)
Height H2		408 (16.06)	459 (18.07)	509 (20.04)	560 (22.05)	611 (24.06)	662 (26.06)
Height Hr		815 (32.09)	926 (36.46)	1018 (40.08)	1144 (45.04)	1253 (49.33)	1344 (52.91)
Inner Diameter of Eye Bolt		35 (1.38)	35 (1.38)	35 (1.38)	40 (1.57)	50 (1.97)	50 (1.97)
Approx. Weight, Unit: kg (lb)		184 (406)	288 (635)	374 (825)	520 (1146)	716 (1579)	826 (1821)

Note: When submersible type or option code DHC is selected, waterproof glands and a 30-meter length cable are attached. Add 9.5 kg (20.9 lb) to the weight in the table.

(9) JIS F12 (JIS 75M) Flange Type

Unit: mm (approx. in.)

Process Connection Code		CG1					
Flange Type		JIS G3443-2 F12					
Size Code		500	600	700	800	900	10L
Size		500 (20)	600 (24)	700 (28)	800 (32)	900 (36)	1000 (40)
Lining Code		U					
Lay Length L		600 (23.62)	720 (28.35)	840 (33.07)	960 (37.80)	1080 (42.52)	1200 (47.24)
Flange Outer Diameter ϕ D		706 (27.80)	810 (31.89)	928 (36.54)	1034 (40.71)	1156 (45.51)	1262 (49.69)
Bolt Circle Diameter ϕ C		639 (25.16)	743 (29.25)	854 (33.62)	960 (37.80)	1073 (42.24)	1179 (46.42)
Inner Diameter ϕ d	Lining U	469 (18.46)	570 (22.44)	667 (26.26)	769 (30.28)	870 (34.25)	968 (38.11)
Bolt Hole Pitch Half Angle θ		15°	11.3°	11.3°	9°	9°	7.5°
Bolt Hole Diameter ϕ h		27 (1.06)	27 (1.06)	33 (1.30)	33 (1.30)	33 (1.30)	33 (1.30)
Number of Bolt Holes N		12	16	16	20	20	24
Height H1		766 (30.16)	870 (34.25)	988 (38.90)	1105 (43.50)	1227 (48.31)	1352 (53.23)
Height H2		408 (16.06)	459 (18.07)	509 (20.04)	560 (22.05)	611 (24.06)	662 (26.06)
Height Hr		816 (32.13)	919 (36.18)	1028 (40.47)	1132 (44.57)	1245 (49.02)	1349 (53.11)
Inner Diameter of Eye Bolt		35 (1.38)	35 (1.38)	35 (1.38)	40 (1.57)	40 (1.57)	50 (1.97)
Approx. Weight, Unit: kg (lb)		168 (370)	228 (503)	319 (703)	404 (891)	540 (1190)	703 (1550)

Note: When submersible type or option code DHC is selected, waterproof glands and a 30-meter length cable are attached. Add 9.5 kg (20.9 lb) to the weight in the table.

● Optional Grounding Rings (GR1) for sizes 500 mm (20 in.) to 1000 mm (40 in.)

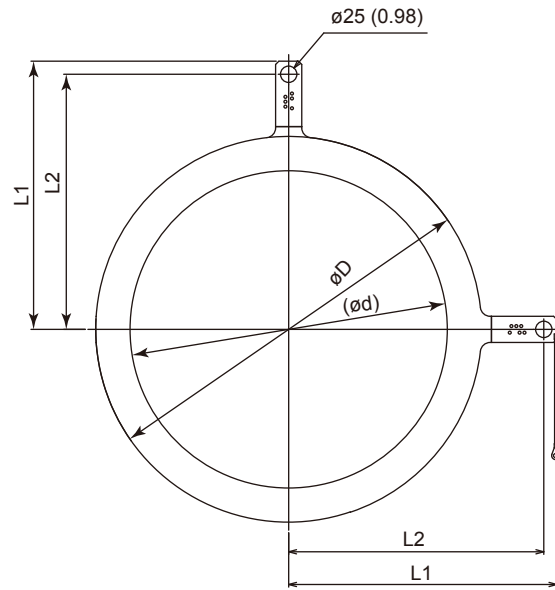

F0604.ai

Unit: mm (approx. in.)

Process Connection Code	CA1, CB1, CE1, CE2, CJ1, CS1, CS2, CT1, CG1					
Size Code	500	600	700	800	900	10L
Size	500 (20)	600 (24)	700 (28)	800 (32)	900 (36)	1000 (40)
Lining Code	H, F, U, D					
Ring Outer Diameter øD	590 (23.23)	690 (27.17)	799 (31.46)	906 (35.67)	1006 (39.61)	1116 (43.94)
Ring Inner Diameter ød	485 (19.09)	586 (23.07)	683 (26.89)	787 (30.98)	888 (34.96)	986 (38.82)
Length L1	410 (16.14)	477.5 (18.80)	517.5 (20.37)	586 (23.07)	640 (25.20)	697.5 (27.46)
Length L2	390 (15.35)	457.5 (18.01)	497.5 (19.59)	566 (22.28)	620 (24.41)	677.5 (26.67)
Thickness	4 (0.16)					
Approx. Weight, Unit: kg (lb)	3.1 (6.8)	3.7 (8.1)	4.6 (10.2)	5.4 (12.0)	6.0 (13.3)	7.3 (16.1)

● AXW11L to AXW18L, Sizes 1100 mm (44 in.) to 1800 mm (72 in.)

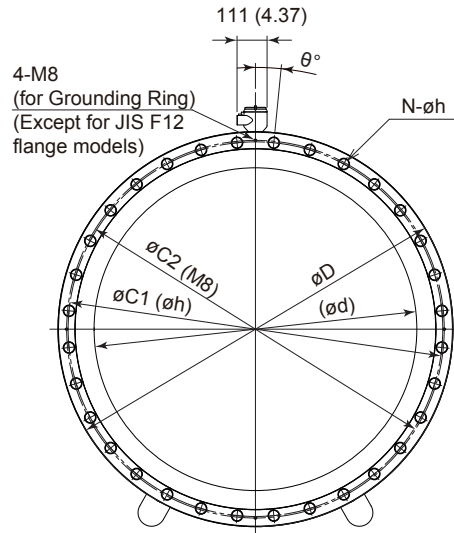
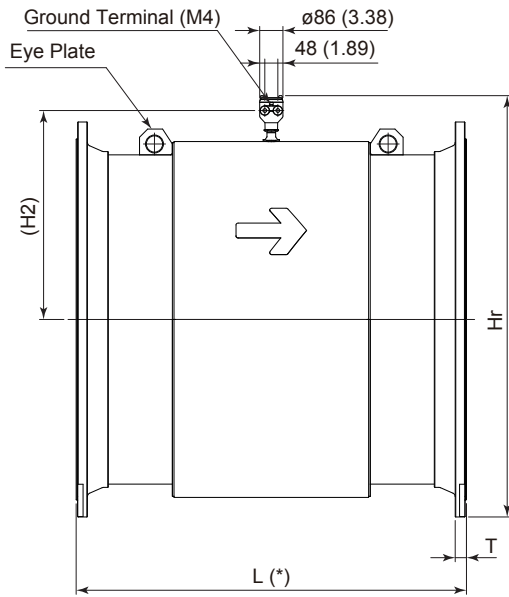

*: The thickness of optional grounding rings (5 mm for GR1 and 25 mm for GR2 per one) and customer supplied gaskets are not included in "L" here.

F0605.ai

(1) AWWA Flange Type

Unit: mm (approx. in.)

Process Connection Code	CB1	
Flange Type	AWWA C207 Class D	
Size Code	12L	
Size	1200 (48)	
Lining Code	H	
Lay Length L	1440 (56.69)	
Flange Outer Diameter øD	1511.3 (59.50)	
Flange Bolt Circle Diameter øC1	1422.4 (56.00)	
Ring Bolt Circle Diameter øC2	1426 (56.14)	
Inner Diameter ød	Lining H	1189 (46.81)
Bolt Hole Pitch Half Angle θ	4.1°	
Bolt Hole Diameter øh	41.3 (1.625)	
Number of Bolt Holes N	44	
Height H2	770 (30.31)	
Height Hr	1580 (62.20)	
Inner Diameter of Eye Plate	60 (2.36)	
Approx. Weight, Unit: kg (lb)	930 (2050)	

Note: When submersible type or option code DHC is selected, waterproof glands and a 30-meter length cable are attached. Add 9.5 kg (20.9 lb) to the weight in the table.

(2) EN PN6 Flange Type

Unit: mm (approx. in.)

Process Connection Code		CEJ			
Flange Type		EN1092-1 PN6			
Size Code		12L	14L	16L	18L
Size		1200 (48)	1400 (56)	1600 (64)	1800 (72)
Lining Code		H			
Lay Length L		1440 (56.69)	1680 (66.14)	1920 (75.59)	2160 (85.04)
Flange Outer Diameter ϕ D		1405 (55.31)	1630 (64.17)	1830 (72.05)	2045 (80.51)
Flange Bolt Circle Diameter ϕ C1		1340 (52.76)	1560 (61.42)	1760 (69.29)	1970 (77.56)
Ring Bolt Circle Diameter ϕ C2		1356 (53.39)	1572 (61.89)	1772 (69.76)	1981 (77.99)
Inner Diameter ϕ d	Lining H	1195 (47.05)	1398 (55.04)	1586 (62.44)	1784 (70.24)
Bolt Hole Pitch Half Angle θ		5.6°	5°	4.5°	4.1°
Bolt Hole Diameter ϕ h		33 (1.30)	36 (1.42)	36 (1.42)	39 (1.54)
Number of Bolt Holes N		32	36	40	44
Height H2		770 (30.31)	873 (34.37)	969 (38.15)	1068 (42.05)
Height Hr		1527 (60.12)	1742 (69.49)	1938 (76.30)	2145 (84.45)
Inner Diameter of Eye Plate		60 (2.36)	70 (2.76)	70 (2.76)	80 (3.15)
Approx. Weight, Unit: kg (lb)		620 (1367)	920 (2028)	1310 (2888)	1670 (3682)

Note: When submersible type or option code DHC is selected, waterproof glands and a 30-meter length cable are attached. Add 9.5 kg (20.9 lb) to the weight in the table.

(3) EN PN10 Flange Type (fluid pressure up to 0.6 MPa)

Unit: mm (approx. in.)

Process Connection Code		CEK			
Flange Type		EN1092-1 PN10			
Size Code		12L	14L	16L	18L
Size		1200 (48)	1400 (56)	1600 (64)	1800 (72)
Lining Code		H			
Lay Length L		1440 (56.69)	1680 (66.14)	1920 (75.59)	2160 (85.04)
Flange Outer Diameter ϕ D		1455 (57.28)	1675 (65.94)	1915 (75.39)	2115 (83.27)
Flange Bolt Circle Diameter ϕ C1		1380 (54.33)	1590 (62.60)	1820 (71.65)	2020 (79.53)
Ring Bolt Circle Diameter ϕ C2		1391 (54.76)	1596 (62.83)	1822 (71.73)	2022 (79.61)
Inner Diameter ϕ d	Lining H	1195 (47.05)	1398 (55.04)	1586 (62.44)	1784 (70.24)
Bolt Hole Pitch Half Angle θ		5.6°	5°	4.5°	4.1°
Bolt Hole Diameter ϕ h		39 (1.54)	42 (1.65)	48 (1.89)	48 (1.89)
Number of Bolt Holes N		32	36	40	44
Height H2		770 (30.31)	873 (34.37)	969 (38.15)	1068 (42.05)
Height Hr		1552 (61.10)	1765 (69.49)	1981 (77.99)	2180 (85.83)
Inner Diameter of Eye Plate		60 (2.36)	70 (2.76)	70 (2.76)	80 (3.15)
Approx. Weight, Unit: kg (lb)		790 (1742)	1120 (2469)	1720 (3792)	2130 (4696)

Note: When submersible type or option code DHC is selected, waterproof glands and a 30-meter length cable are attached. Add 9.5 kg (20.9 lb) to the weight in the table.

(4) EN PN10 Flange Type

Unit: mm (approx. in.)

Process Connection Code		CE1			
Flange Type		EN1092-1 PN10			
Size Code		12L	14L	16L	18L
Size		1200 (48)	1400 (56)	1600 (64)	1800 (72)
Lining Code		H			
Lay Length L		1440 (56.69)	1680 (66.14)	1920 (75.59)	2160 (85.04)
Flange Outer Diameter ϕ D		1455 (57.28)	1675 (65.94)	1915 (75.39)	2115 (83.27)
Flange Bolt Circle Diameter ϕ C1		1380 (54.33)	1590 (62.60)	1820 (71.65)	2020 (79.53)
Ring Bolt Circle Diameter ϕ C2		1391 (54.76)	1596 (62.83)	1822 (71.73)	2022 (79.61)
Inner Diameter ϕ d	Lining H	1189 (46.81)	1390 (54.72)	1582 (62.28)	1776 (69.92)
Bolt Hole Pitch Half Angle θ		5.6°	5°	4.5°	4.1°
Bolt Hole Diameter ϕ h		39 (1.54)	42 (1.65)	48 (1.89)	48 (1.89)
Number of Bolt Holes N		32	36	40	44
Height H2		770 (30.31)	873 (34.37)	969 (38.15)	1068 (42.05)
Height Hr		1552 (61.10)	1765 (69.49)	1981 (77.99)	2180 (85.83)
Inner Diameter of Eye Plate		60 (2.36)	70 (2.76)	70 (2.76)	80 (3.15)
Approx. Weight, Unit: kg (lb)		920 (2028)	1340 (2954)	1860 (4101)	2510 (5534)

Note: When submersible type or option code DHC is selected, waterproof glands and a 30-meter length cable are attached. Add 9.5 kg (20.9 lb) to the weight in the table.

(5) AS2129 Table D, AS2129 Table E, AS4087 PN16 Flange Type

Unit: mm (approx. in.)

Process Connection Code		CS1	CS2	CT1
Flange Type		AS2129 Table D	AS2129 Table E	AS4087 PN16
Size Code		12L	12L	12L
Size		1200 (48)	1200 (48)	1200 (48)
Lining Code		H		
Lay Length L		1440 (56.69)	1440 (56.69)	1440 (56.69)
Flange Outer Diameter ϕ D		1490 (58.66)	1490 (58.66)	1490 (58.66)
Flange Bolt Circle Diameter ϕ C1		1410 (55.51)	1410 (55.51)	1410 (55.51)
Ring Bolt Circle Diameter ϕ C2		1426 (56.14)	1426 (56.14)	1426 (56.14)
Inner Diameter ϕ d	Lining H	1189 (46.81)	1189 (46.81)	1189 (46.81)
Bolt Hole Pitch Half Angle θ		5.6°	5.6°	5.6°
Bolt Hole Diameter ϕ h		36 (1.42)	39 (1.54)	36 (1.42)
Number of Bolt Holes N		32	32	32
Height H2		770 (30.31)	770 (30.31)	770 (30.31)
Height Hr		1570 (61.81)	1570 (61.81)	1570 (61.81)
Inner Diameter of Eye Plate		60 (2.36)	60 (2.36)	60 (2.36)
Approx. Weight, Unit: kg (lb)		1050 (2315)	1210 (2668)	1180 (2601)

Note: When submersible type or option code DHC is selected, waterproof glands and a 30-meter length cable are attached. Add 9.5 kg (20.9 lb) to the weight in the table.

(6) JIS F12 (JIS 75M) Flange Type

Unit: mm (approx. in.)

Process Connection Code		CG1					
Flange Type		JIS G3443-2 F12					
Size Code		11L	12L	13L	15L	16L	18L
Size		1100 (44)	1200 (48)	1350 (54)	1500 (60)	1600 (64)	1800 (72)
Lining Code		U					
Lay Length L		1320 (51.97)	1440 (56.69)	1620 (63.78)	1800 (70.87)	1920 (75.59)	2160 (85.04)
Flange Outer Diameter ϕ D		1366 (53.78)	1470 (57.87)	1642 (64.65)	1800 (70.87)	1915 (75.39)	2115 (83.27)
Bolt Circle Diameter ϕ C		1283 (50.51)	1387 (54.61)	1552 (61.10)	1710 (67.32)	1820 (71.65)	2020 (79.53)
Grounding Ring Inner Diameter ϕ d	Lining U	1071 (42.17)	1172 (46.14)	1322 (52.05)	1469 (57.83)	1565 (61.61)	1759 (69.25)
Bolt Hole Pitch Half Angle θ		7.5°	6.4°	6.4°	5.6°	5°	4.1°
Bolt Hole Diameter ϕ h		33 (1.30)	33 (1.30)	39 (1.54)	39 (1.54)	39 (1.54)	39 (1.54)
Number of Bolt Holes N		24	28	28	32	36	44
Height H2		720 (28.35)	770 (30.31)	873 (34.37)	921 (36.26)	969 (38.15)	1068 (42.05)
Height Hr		1457 (57.36)	1560 (61.42)	1723 (67.83)	1875 (73.82)	1981 (77.99)	2180 (85.83)
Inner Diameter of Eye Plate		60 (2.36)	60 (2.36)	70 (2.76)	70 (2.76)	70 (2.76)	80 (3.15)
Approx. Weight, Unit: kg (lb)		910 (2006)	1060 (2337)	1430 (3153)	1770 (3902)	2090 (4608)	2890 (6371)

Note: When submersible type or option code DHC is selected, waterproof glands and a 30-meter length cable are attached. Add 9.5 kg (20.9 lb) to the weight in the table.

● Optional Grounding Rings (GR1) for sizes 1200 mm (48 in.) to 1800 mm (72 in.)

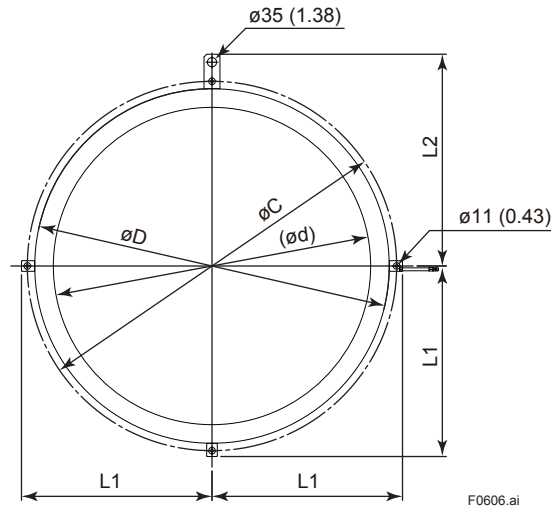

Unit: mm (approx. in.)

Process Connection Code	CB1, CS1, CS2,CT1	CEJ				CEK, CE1			
Flange Type	AWWA C207-D AS2129-D,E AS4087 PN16	EN PN6				EN PN10			
Size Code	12L	12L	14L	16L	18L	12L	14L	16L	18L
Size	1200 (48)	1200 (48)	1400 (56)	1600 (64)	1800 (72)	1200 (48)	1400 (56)	1600 (64)	1800 (72)
Lining Code	H								
Ring Outer Diameter øD	1370 (53.94)	1300 (51.18)	1516 (59.69)	1716 (67.56)	1925 (75.79)	1335 (52.56)	1540 (60.63)	1766 (69.53)	1966 (77.40)
Ring Inner Diameter ød	1195 (47.05)	1201 (47.28)	1404 (55.28)	1592 (62.68)	1790 (70.47)	1195 (47.05)	1396 (54.96)	1588 (62.52)	1782 (70.16)
Bolt Circle Diameter øC	1426 (56.14)	1356 (53.39)	1572 (61.89)	1772 (69.76)	1981 (77.99)	1391 (54.76)	1596 (62.83)	1822 (71.73)	2022 (79.61)
Length L1	735 (28.94)	700 (27.56)	808 (31.81)	908 (35.75)	1012.5 (39.86)	717.5 (28.25)	820 (32.28)	933 (36.73)	1033 (40.67)
Length L2	815 (32.09)	780 (30.71)	888 (34.96)	988 (38.90)	1092.5 (43.01)	797.5 (31.40)	900 (35.43)	1013 (39.88)	1113 (43.82)
Thickness	5 (0.20)								
Approx. Weight, Unit: kg (lb)	14.6 (32.2)	8.2 (18.1)	10.7 (23.6)	13.3 (29.3)	16.2 (35.7)	11.6 (25.6)	13.7 (30.2)	19.2 (42.3)	22.1 (48.7)

● **Optional Grounding Rings (GR2) for sizes 1100 mm (44 in.) to 1800 mm (72 in.)**

Unit: mm (approx. in.)

Process Connection Code	CG1					
Flange Type	JIS F12 (JIS 75M)					
Size Code	11L	12L	13L	15L	16L	18L
Size	1100 (44)	1200 (48)	1350 (54)	1500 (60)	1600 (64)	1800 (72)
Lining Code	U					
Thickness	25 (0.98)					
Approx. Weight, Unit: kg (lb)	59.3 (131)	65.7 (145)	75.8 (167)	88.3 (195)	92.4 (204)	114.2 (252)

*: Optional grounding rings (GR2) have no protruding brackets and are installed and locked onto the flowtube with gaskets B when shipped from factory. Refer to "CAUTIONS FOR INSTALLATION".

Note: Unless otherwise specified, refer to the following table for tolerance in the dimensions.

General tolerance in the dimensional outline drawing.

Unit: mm (approx. in.)

Category of basic dimension		Tolerance	Category of basic dimension		Tolerance
Above	Equal or below		Above	Equal or below	
	3 (0.12)	±0.7 (±0.03)	500 (19.69)	630 (24.80)	±5.5 (±2.17)
3 (0.12)	6 (0.24)	±0.9 (±0.04)	630 (24.80)	800 (31.50)	±6.25 (±0.25)
6 (0.24)	10 (0.39)	±1.1 (±0.04)	800 (31.50)	1000 (39.37)	±7.0 (±0.28)
10 (0.39)	18 (0.71)	±1.35 (±0.05)	1000 (39.37)	1250 (49.21)	±8.25 (±0.32)
18 (0.71)	30 (1.18)	±1.65 (±0.06)	1250 (49.21)	1600 (62.99)	±9.75 (±0.38)
30 (1.18)	50 (1.97)	±1.95 (±0.08)	1600 (62.99)	2000 (78.74)	±11.5 (±0.45)
50 (1.97)	80 (3.15)	±2.3 (±0.09)	2000 (78.74)	2500 (98.43)	±14.0 (±0.55)
80 (3.15)	120 (4.72)	±2.7 (±0.11)	2500 (98.43)	3150 (124.02)	±16.5 (±0.65)
120 (4.72)	180 (7.09)	±3.15 (±0.12)			
180 (7.09)	250 (9.84)	±3.6 (±0.14)			
250 (9.84)	315 (12.40)	±4.05 (±0.16)			
315 (12.40)	400 (15.75)	±4.45 (±0.18)			
400 (15.75)	500 (19.69)	±4.85 (±0.19)			

Remarks: The numeric is based on criteria of tolerance class IT18 in JIS B 0401.

■ SIZING DATA

Note: Measurable flow velocity is from 0 m/s.

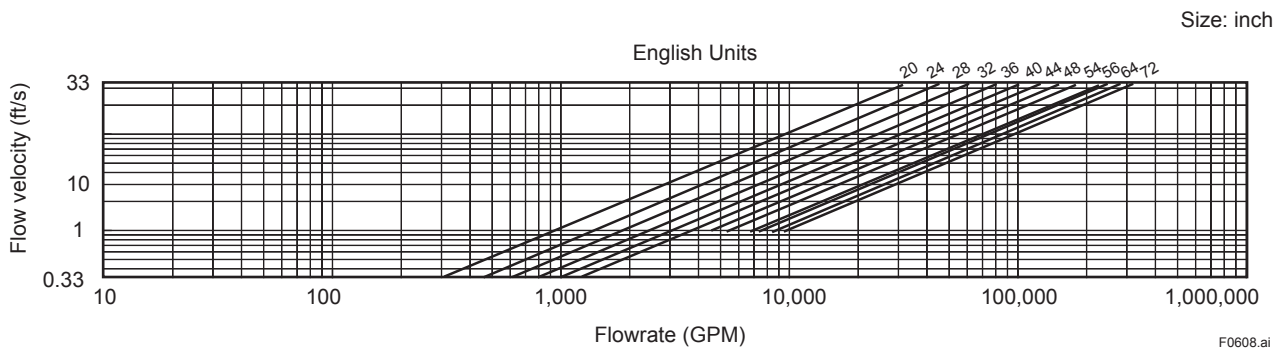
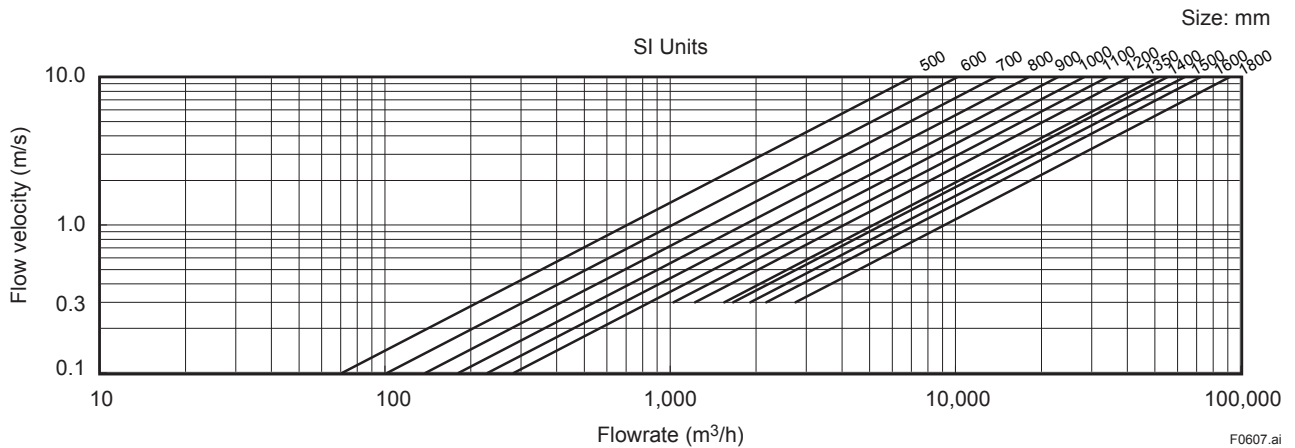

Revision Information

- Title : AXW Magnetic Flowmeter Remote Flowtube
- Manual No. : IM 01E25D11-01EN

Edition	Date	Page	Revised Item
1st	Mar. 2012	–	New publication
2nd	Sep. 2013	–	Addition of sizes from 1100 mm (44 in.) to 1800 mm (72 in.). Addition of lining material and flange standard.