



Eclipse

Direct Vent System

heatilator[®]
The first name in fireplaces

Eclipse Direct Vent System

The best-valued hearth system in the industry.

- The Eclipse is competitively priced in its category so it can now be included as standard—even in floor plans that previously couldn't afford one
- The Eclipse creates a great opportunity to sell a second fireplace in a home design
- Top direct-vent system only
- 20,000 Btu/Hour input for comfortable heat output
- Direct vent system uses only outside air for combustion and vents outside for better indoor air quality and a healthy home
- Optional fan available
- Comes standard in natural gas or LP models
- Models available in both standing pilot and IntelliFire™ ignition systems
- Utilizes SL-D venting components
- Tested and listed to ANSI standards



Eclipse Direct Vent System shown with custom tile surround

Models

- EDV3633 Standing pilot, natural gas
- EDV3633I IntelliFire ignition, natural gas
- EDV3633IL IntelliFire ignition, LP gas

Options*

- Fan Kit
- Conversion Kits
- Remote Controls

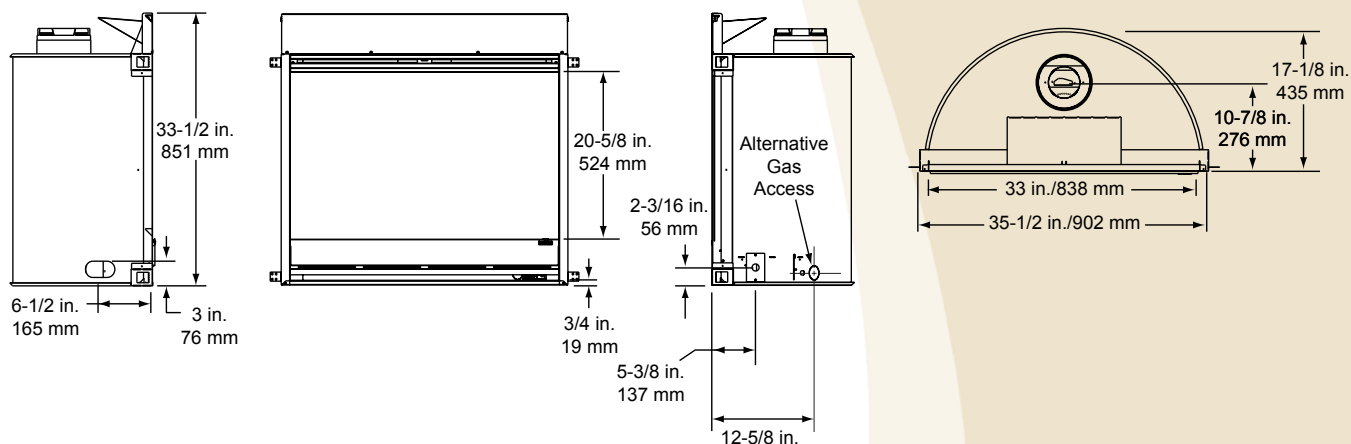

AVAILABLE FROM

heatilator®
The first name in fireplaces

a brand of Hearth & Home Technologies Inc.

1915 West Saunders Street • Mt. Pleasant, Iowa 52641
 800-927-6841 • heatilator.com

The information provided in this literature is for planning purposes only. Please consult the installation manual for actual installation. Actual product appearance may differ from product images.

*For a complete list of options, please consult the Heatilator MSRP book.

HTL-1047U-0308