



User's Information Manual Models: 399 - 800



Lochinvar[®]
High Efficiency Water Heaters, Boilers and Pool Heaters

⚠ WARNING

If the information in this manual is not followed exactly, a fire or explosion may result causing property damage, personal injury or loss of life.

This appliance **MUST NOT** be installed in any location where gasoline or flammable vapors are likely to be present.

WHAT TO DO IF YOU SMELL GAS

- Do not try to light any appliance.
- Do not touch any electric switch; do not use any phone in your building.
- Immediately call your gas supplier from a near by phone. Follow the gas supplier's instructions.
- If you cannot reach your gas supplier, call the fire department.
- Installation and service must be performed by a qualified installer, service agency, or the gas supplier.

Save this manual for future reference.

Contents

HAZARD DEFINITIONS	2	3. OPERATING INSTRUCTIONS	9
PLEASE READ BEFORE PROCEEDING	3	4. SMART SYSTEM CONTROL MODULE	
1. PREVENT COMBUSTION AIR CONTAMINATION ...	4	Knight XL Control Module	10
2. MAINTENANCE SCHEDULE	5	Access Modes	11
Maintenance Procedures	6	Saving Parameters	11
Boiler Must Be Serviced and Maintained	6	Parameter Table	12
Check Boiler Area	6	A: General	13
Check Pressure Temperature Gauge	6	B: Temperature Settings	13
Check Vent Piping	6	C: Data Logging	13
Check Air Piping	6	E: DHW Settings	14
Check Relief Valve	6	F: Outdoor Air Reset	14
Check Condensate Drain System	6-7	Status Display Screens	15-18
Check Automatic Air Vents	8	NOTES	19
Test Low Water Cutoff (if installed)	8	Revision Notes	Back Cover
Reset Button (low water cutoff)	8		
Check Boiler Piping (gas and water)	8		
Operate Relief Valve	8		
Shut Boiler Down	8		

Hazard definitions

The following defined terms are used throughout this manual to bring attention to the presence of hazards of various risk levels or to important information concerning the life of the product.

⚠ DANGER

DANGER indicates an imminently hazardous situation which, if not avoided, will result in death or serious injury.

⚠ WARNING

WARNING indicates a potentially hazardous situation which, if not avoided, could result in death or serious injury.

⚠ CAUTION

CAUTION indicates a potentially hazardous situation which, if not avoided, may result in minor or moderate injury.

CAUTION

CAUTION used without the safety alert symbol indicates a potentially hazardous situation which, if not avoided, may result in property damage.

NOTICE

NOTICE indicates special instructions on installation, operation, or maintenance that are important but not related to personal injury or property damage.

Please read before proceeding

NOTICE

The Knight XL Installation and Operation Manual along with the Knight XL Service Manual are for use only by a qualified heating installer/service technician. Refer only to this User's Information Manual for your reference. Improper installation, adjustment, alteration, service or maintenance can cause property damage, personal injury (exposure to hazardous materials) or loss of life. Installation and service must be performed by a qualified installer, service agency or the gas supplier (who must read and follow the supplied instruction before installing, servicing, or removing this boiler. This boiler contains materials that have been identified as carcinogenic, or possibly carcinogenic, to humans).

NOTICE

When calling or writing about the boiler – Please have the boiler model and serial number from the boiler rating plate.

Consider piping and installation when determining boiler location.

Any claims for damage or shortage in shipment must be filed immediately against the transportation company by the consignee.

Factory warranty (shipped with unit) does not apply to units improperly installed or improperly operated.

⚠ WARNING

Failure to adhere to the guidelines on this page can result in severe personal injury, death, or substantial property damage.

Boiler service and maintenance –

- To avoid electric shock, disconnect electrical supply before performing maintenance.
- To avoid severe burns, allow boiler to cool before performing maintenance.

Boiler operation –

- Do not block flow of combustion or ventilation air to the boiler. This boiler is equipped with a control which will automatically shut down the boiler should air or vent be blocked. If vent or air blockage is easily accessible and removable, remove it. The boiler should attempt to restart. If blockage is not obvious or cannot be removed, have the boiler and system checked by a qualified service technician.
- Should overheating occur or gas supply fail to shut off, do not turn off or disconnect electrical supply to the circulator. Instead, shut off the gas supply at a location external to the appliance.
- Do not use this boiler if any part has been under water. The possible damage to a flooded appliance can be extensive and present numerous safety hazards. Any appliance that has been under water must be replaced.

Boiler water –

- Thoroughly flush the system (without boiler connected) to remove sediment. The high-efficiency heat exchanger can be damaged by build-up or corrosion due to sediment.
- Do not use petroleum-based cleaning or sealing compounds in the boiler system. Gaskets and seals in the system may be damaged. This can result in substantial property damage.
- Do not use “homemade cures” or “boiler patent medicines”. Serious damage to the boiler, personnel, and/or property may result.
- Continual fresh make-up water will reduce boiler life. Mineral buildup in the heat exchanger reduces heat transfer, overheats the stainless steel heat exchanger, and causes failure. Addition of oxygen carried in by makeup water can cause internal corrosion. Leaks in boiler or piping must be repaired at once to prevent makeup water.

Freeze protection fluids –

- NEVER use automotive antifreeze. Use only inhibited propylene glycol solutions, which are specifically formulated for hydronic systems. Ethylene glycol is toxic and can attack gaskets and seals used in hydronic systems.

1 Prevent combustion air contamination

⚠ WARNING If the boiler combustion air inlet is located in any area likely to cause contamination, or if products which would contaminate the air cannot be removed, you must have the combustion air and vent re-piped and terminated to another location. Contaminated combustion air will damage the boiler, resulting in possible severe personal injury, death, or substantial property damage.

⚠ WARNING If the boiler combustion air inlet is located in a laundry room or pool facility, for example, these areas will always contain hazardous contaminants.

Pool and laundry products and common household and hobby products often contain fluorine or chlorine compounds. When these chemicals pass through the boiler, they can form strong acids. The acid can eat through the boiler wall, causing serious damage and presenting a possible threat of flue gas spillage or boiler water leakage into the building.

Please read the information listed in Table 1A. If contaminating chemicals will be present near the location of the boiler combustion air inlet, have your installer pipe the boiler combustion air and vent to another location, per the Knight XL Installation and Operation Manual.

⚠ WARNING To prevent the potential of severe personal injury or death, check for areas and products listed in Table 1A before installing the boiler or air inlet piping.

- If contaminants are found, you **MUST**:
- Remove contaminants permanently.
 - OR—
 - Relocate air inlet and vent terminations to other areas.

Table 1A Corrosive Contaminants and Sources

Products to avoid:
Spray cans containing chloro/fluorocarbons
Permanent wave solutions
Chlorinated waxes/cleaners
Chlorine-based swimming pool chemicals
Calcium chloride used for thawing
Sodium chloride used for water softening
Refrigerant leaks
Paint or varnish removers
Hydrochloric acid/muriatic acid
Cements and glues
Antistatic fabric softeners used in clothes dryers
Chlorine-type bleaches, detergents, and cleaning solvents found in household laundry rooms
Adhesives used to fasten building products and other similar products
Areas likely to have contaminants
Dry cleaning/laundry areas and establishments
Swimming pools
Metal fabrication plants
Beauty shops
Refrigeration repair shops
Photo processing plants
Auto body shops
Plastic manufacturing plants
Furniture refinishing areas and establishments
New building construction
Remodeling areas
Garages with workshops

2 Maintenance schedule

Service technician (see the Knight XL Service Manual)		Owner maintenance (see pages 6 - 8 for detailed instructions)	
ANNUAL START-UP	General:	Daily	<ul style="list-style-type: none"> • Check boiler area • Check pressure/temperature gauge
	<ul style="list-style-type: none"> • Address reported problems • Inspect interior; clean and vacuum if necessary; • Clean condensate trap and fill with fresh water • Check for leaks (water, gas, flue, condensate) • Verify flue and air lines in good condition and sealed tight • Check system water pressure/system piping/expansion tank • Check control settings • Check ignition and flame sense electrodes (sand off any deposits; clean and reposition) • Check wiring and connections • Perform start-up checkout and performance verification per Section 10 in the Knight XL Installation and Operation Manual. • Flame inspection (stable, uniform) • Flame signal (at least 10 microamps at high fire) • Clean the heat exchanger if flue temperature is more than 54°F (30°C) above return water temperature. 	Monthly	<ul style="list-style-type: none"> • Check vent piping • Check air piping • Check air and vent termination screens • Check relief valve • Check condensate drain system • Check automatic air vents
	<p>If combustion or performance indicate need:</p> <ul style="list-style-type: none"> • Clean heat exchanger • Remove and clean burner using compressed air only • Clean the blower wheel 	Periodically	<ul style="list-style-type: none"> • Test low water cutoff (if used) • Reset button (low water cutoff)
		Every 6 months	<ul style="list-style-type: none"> • Check boiler piping (gas and water) for leaks • Operate relief valve
		End of season months	<ul style="list-style-type: none"> • Shut boiler down (unless boiler used for domestic hot water)

⚠ WARNING

Follow the maintenance procedures given throughout this manual. Failure to perform the service and maintenance or follow the directions in this manual could result in damage to the boiler or system, resulting in severe personal injury, death, or substantial property damage.

2 Maintenance schedule

Maintenance procedures

Boiler must be serviced and maintained

⚠ WARNING

The boiler must be inspected and started annually at the beginning of the heating season by a qualified service technician. In addition, the maintenance and care of the boiler designated on page 5 of this manual and explained on pages 6 through 8 must be performed to assure maximum boiler efficiency and reliability. Failure to service and maintain the boiler and system could result in equipment failure, causing possible severe personal injury, death, or substantial property damage.

NOTICE

The following information provides detailed instructions for completing the maintenance items listed in the maintenance schedule on page 5. In addition to this maintenance, the boiler must be serviced and started up at the beginning of each heating season by a qualified service technician.

Check boiler area

⚠ WARNING

To prevent potential of severe personal injury, death, or substantial property damage, eliminate all materials discussed below from the boiler vicinity and the vicinity of the boiler combustion air inlet. If contaminants are found:

Remove products immediately from the area. If they have been there for an extended period, call a qualified service technician to inspect the boiler for possible damage from acid corrosion.

If products cannot be removed, immediately call a qualified service technician to re-pipe vent and air piping and locate vent termination/air intake away from contaminated areas.

1. Combustible/flammable materials -- Do not store combustible materials, gasoline or any other flammable vapors or liquids near the boiler. Remove immediately if found.
2. Air contaminants -- Products containing chlorine or fluorine, if allowed to contaminate the boiler intake air, will cause acidic condensate in the boiler. This will cause significant damage to the boiler if allowed to continue.

Read the list of potential materials listed in Table 1A on page 4 of this manual. If any of these products are in the room from which the boiler takes its combustion air, they must be removed immediately or the boiler combustion air (and vent termination) must be relocated to another area.

Check pressure/temperature gauge

1. Make sure the pressure reading on the boiler pressure/temperature gauge does not exceed 24 psi (165.5 kPa). Higher pressure may indicate a problem with the expansion tank.
2. Contact a qualified service technician if problem persists.

Check vent piping

1. Visually inspect the flue gas vent piping for any signs of blockage, leakage, or deterioration of the piping. Notify your qualified service technician at once if you find any problems.

⚠ WARNING

Failure to inspect the vent system as noted above and have it repaired by a qualified service technician can result in vent system failure, causing severe personal injury or death.

Check air piping

1. Visually inspect the air inlet termination to be sure it is unobstructed. Inspect the entire length of air piping to ensure piping is intact and all joints are properly sealed.
2. Call your qualified service technician if you notice any problems.

Check relief valve

1. Inspect the boiler relief valve and the relief valve discharge pipe for signs of weeping or leakage.
2. If the relief valve often weeps, the expansion tank may not be working properly. Immediately contact your qualified service technician to inspect the boiler and system.

Check condensate drain system

1. Inspect the condensate drain line, condensate PVC fittings and condensate trap.

Fill condensate trap with water

1. Remove the PVC cap retaining screw from the PVC cap (FIG. 2-1).
2. Remove the 2" PVC cap with the switch located at the top of the trap (FIG. 2-1).

2 Maintenance schedule *(continued)*

3. Fill with fresh water until the water begins to pour out of the drain.
4. Replace the cap. Press the cap onto the trap until the cap makes contact with the drain.
5. Replace the retaining screw.

⚠ WARNING

The condensate trap (FIG. 2-1) must be filled with water during all times of boiler operation to avoid flue gas emission from the condensate drain line. Failure to fill the trap could result in severe personal injury or death.

NOTICE

Use materials approved by the authority having jurisdiction. In the absence of other authority, PVC and CPVC pipe must comply with ASTM D1785 or D2845. Cement and primer must comply with ASME D2564 or F493. For Canada use CSA or ULC certified PVC or CPVC pipe, fittings, and cement.

NOTICE

To allow for proper drainage on large horizontal runs, a second line vent may be required and tubing size may need to increase to 1 inch.

The condensate line must remain unobstructed, allowing free flow of condensate. If condensate is allowed to freeze in the line or if the line is obstructed in any other manner, condensate can exit from the boiler tee, resulting in potential water damage to property. Call your qualified service technician to inspect the boiler and system.

Figure 2-1 Condensate Trap

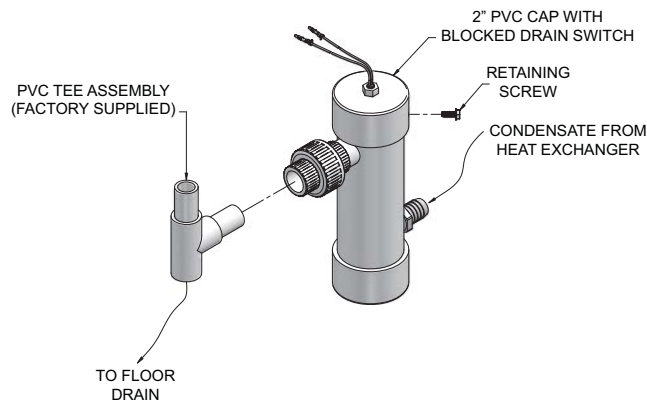

Condensate disposal

1. This boiler is a high efficiency appliance that produces condensate.
2. The side of the boiler has a 1/2 inch PVC union for connection of a 1/2 inch PVC pipe (FIG. 2-2).
3. Slope condensate tubing down and away from the boiler into a drain or condensate neutralizing filter. Condensate from the Knight XL will be slightly acidic (typically with a pH from 3 to 5). Install a neutralizing filter if required by local codes. Call your qualified service technician to inspect the boiler and system.

A Neutralizer Kit is available from the factory (Kit 3087 for Models 399 - 500 and Kit 30002 for Models 600 - 800). Call your qualified service technician to install.

4. Install the 1/2 inch PVC tee assembly (shipped with the unit) as shown in FIG. 2-2. Call your qualified service technician to inspect the boiler and system.
5. Leave the top of the 1/2 inch tee OPEN. This is needed as a vacuum break.
6. Do not expose condensate line to freezing temperatures.
7. Use only plastic tubing or piping as a condensate drain line (FIG. 2-2).

8. A condensate removal pump is required if the boiler is below the drain. When installing a condensate pump, select one approved for use with condensing boilers and furnaces. The pump should have an overflow switch to prevent property damage from condensate spillage. Call your qualified service technician to inspect the boiler and system.

Figure 2-2 Condensate Disposal

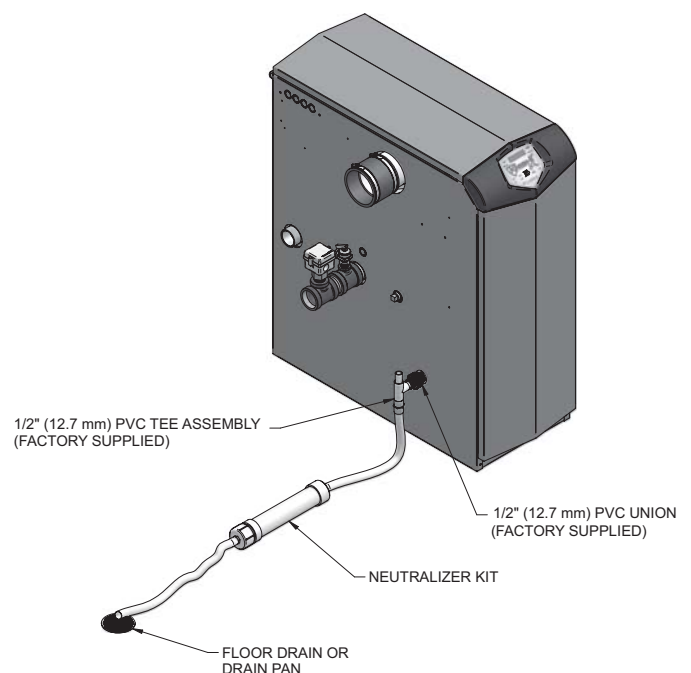

2 Maintenance schedule

Check automatic air vents

1. Reference FIG. 2-3 below.
2. Remove the caps (FIG. 2-3 – “A”) from the automatic air vents in the system and check operation by slightly depressing valve “B” (FIG. 2-3) with the tip of a screwdriver.
3. If the air vent valve appears to be working freely and not leaking, replace cap “A”, twisting the cap all the way on.
4. Loosen cap “A” one turn to allow vent to operate.
5. Have the automatic air vent(s) replaced if it does not operate correctly.

Figure 2-3 Automatic Air Vent

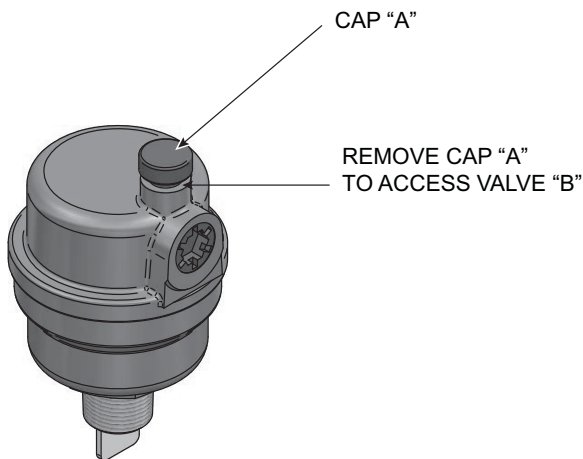

Test low water cutoff (if installed)

1. If the system is equipped with a low water cutoff, test the low water cutoff periodically during the heating season, following the low water cutoff manufacturer's instructions.

Reset button (low water cutoff)

1. Testing the low water cutoff shuts the unit off. Press the RESET button on the low water cutoff to turn the unit back on.

Check boiler piping (gas and water)

1. Remove the boiler front access door and perform a gas leak inspection per steps 1 through 7 of the Operating Instructions on page 9. If gas odor or leak is detected, immediately shut down the boiler following the procedure on page 9. Call a qualified service technician.
2. Visually inspect for leaks around water piping. Also inspect the circulators, relief valve, and fittings. Immediately call a qualified service technician to repair any leaks.

⚠ WARNING

Have leaks fixed at once by a qualified service technician. Failure to comply could result in severe personal injury, death, or substantial property damage.

3. Replace the front access door.

Operate relief valve

1. Before proceeding, verify that the relief valve outlet has been piped to a safe place of discharge, avoiding any possibility of scalding from hot water.

⚠ WARNING

To avoid water damage or scalding due to valve operation, a metal discharge line must be connected to the relief valve outlet and run to a safe place of disposal. This discharge line must be installed by a qualified heating installer or service technician in accordance with the instructions in the Knight XL Installation and Operation Manual. The discharge line must be terminated so as to eliminate possibility of severe burns or property damage should the valve discharge.

2. Read the boiler pressure/temperature gauge to make sure the system is pressurized. Lift the relief valve top lever slightly, allowing water to relieve through the valve and discharge piping.
3. If water flows freely, release the lever and allow the valve to seat. Watch the end of the relief valve discharge pipe to ensure that the valve does not weep after the line has had time to drain. If the valve weeps, lift the seat again to attempt to clean the valve seat. If the valve continues to weep afterwards, contact your qualified service technician to inspect the valve and system.
4. If water does not flow from the valve when you lift the lever completely, the valve or discharge line may be blocked. Immediately shut down the boiler, following the operating instructions on page 9 of this manual. Call your qualified service technician to inspect the boiler and system.

Shut boiler down (unless boiler is used for Domestic Water)

1. Follow “To Turn Off Gas to Appliance” on page 9 of this manual.
2. Do not drain the system unless exposure to freezing temperatures will occur.
3. Do not drain the system if it is filled with an antifreeze solution.
4. DO NOT shut down boilers used for domestic water heating, they must operate year-round.

3 Operating instructions

FOR YOUR SAFETY READ BEFORE OPERATING

WARNING: If you do not follow these instructions exactly, a fire or explosion may result causing property damage, personal injury, or loss of life.

- A. This appliance does not have a pilot. It is equipped with an ignition device which automatically lights the burner. Do not try to light the burner by hand.
- B. BEFORE OPERATING smell all around the appliance area for gas. Be sure to smell next to the floor because some gas is heavier than air and will settle on the floor.
- WHAT TO DO IF YOU SMELL GAS**
- Do not try to light any appliance.
 - Do not touch any electric switch; do not use any phone in your building.
 - Immediately call your gas supplier from a neighbor's phone. Follow the gas supplier's instructions.
 - If you cannot reach your gas supplier, call the fire department.
- C. Use only your hand to turn the gas control knob. Never use tools. If the handle will not turn by hand, don't try to repair it, call a qualified service technician. Force or attempted repair may result in a fire or explosion.
- D. Do not use this appliance if any part has been under water. Immediately call a qualified service technician to inspect the appliance and to replace any part of the control system and any gas control which has been under water.

OPERATING INSTRUCTIONS

1. **STOP!** Read the safety information above on this label.
2. Set the thermostat to lowest setting.
3. Turn off all electric power to the appliance.
4. This appliance is equipped with an ignition device which automatically lights the burner. Do not try to light the burner by hand.
5. Remove top cover.
6. Turn gas shutoff valve counterclockwise to "OFF". Handle will be perpendicular to pipe. Do not force.
7. Wait five (5) minutes to clear out any gas. If you then smell gas, **STOP!** Follow "B" in the safety information above on this label. If you don't smell gas, go to next step.
8. Turn gas shutoff valve clockwise to "ON". Handle will be parallel to pipe.
9. Install top cover.
10. Turn on all electric power to appliance.
11. Set thermostat to desired setting.
12. If the appliance will not operate, follow the instructions "To Turn Off Gas To Appliance" and call your service technician or gas supplier.

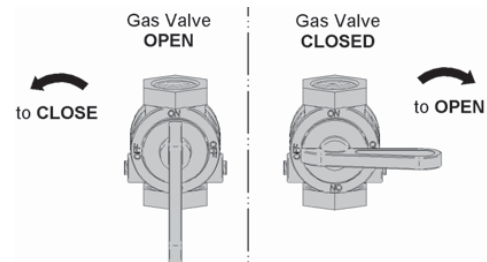

TO TURN OFF GAS TO APPLIANCE

1. Set the thermostat to lowest setting.
2. Turn off all electric power to the appliance if service is to be performed.
3. Remove top cover.
4. Turn gas shut off valve counterclockwise to "OFF". Handle will be perpendicular to pipe. Do not force.
5. Install top cover.

LBL2284 REV -

4 SMART SYSTEM control module

SMART SYSTEM™ Knight XL control module

Use the control panel (FIG. 4-1) to set temperatures, operating conditions, and monitor boiler operation.

Figure 4-1 Control Panel

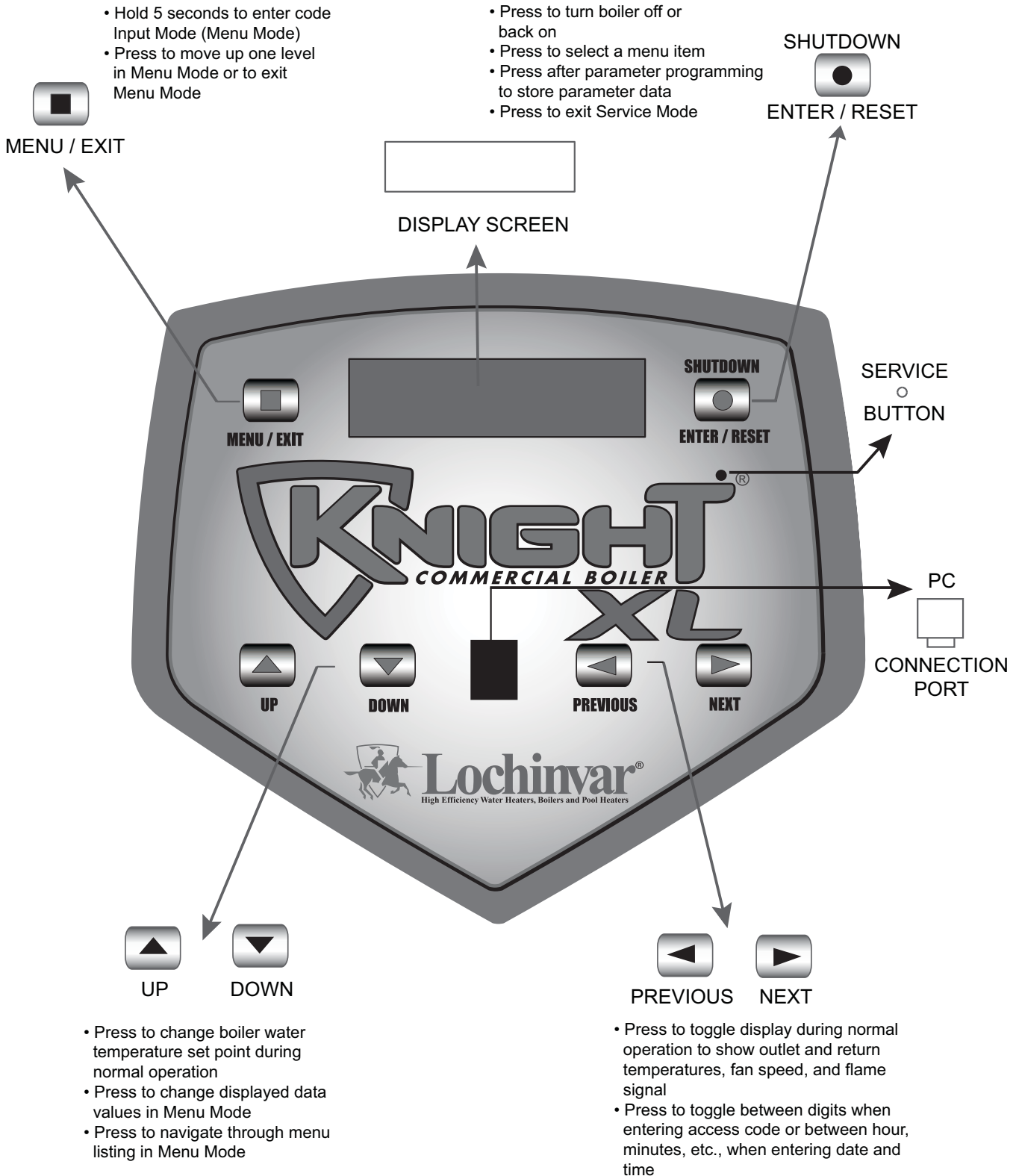

4 SMART SYSTEM control module *(continued)*

Access modes

User

The user can adjust space heating target temperature by using the UP and DOWN buttons (FIG. 4-1) at any time during normal operation. By entering the USER code (0704), the user can also change temperature units, time and date, and night setback settings. In User Mode, the following parameters can be viewed but not changed:

- Boiler outlet water target temperature in DHW Mode
- Boiler model number
- Software version
- Total operating hours
- Total cycles

Installer

Most parameters are available only to the installer, accessible only by entering the installer access code. Have your qualified service technician reference the Knight XL Service Manual.

Saving parameters *(reference parameter table on page 12 of this manual)*

To save parameters and exit programming:

Press the ENTER/RESET button (FIG. 4-1).

To keep parameter settings only for a current operating cycle:

Press the MENU/EXIT button (FIG. 4-1) 3 times after making all desired parameter changes.

To enter a parameter and continue programming:

Press the MENU/EXIT button 1 time to return to the parameter listings; press again to return to the menu listings. Remember to press the ENTER/RESET button when finished programming in order to save the changes made.

Have your qualified service technician reference the Knight XL Service Manual for a detailed description of parameters and access modes.

4 SMART SYSTEM control module

Parameter table

	MENU	SUB ITEM	DESCRIPTION	SEE PAGE	USER ACCESS		INSTALLER ACCESS	
					DISPLAY	MODIFY	DISPLAY	MODIFY
GENERAL	A	1	Boiler Model	13	Yes	No	Yes	No
		2	User Code	13	Yes	Yes	Yes	Yes
		3	Date and Time	13	Yes	Yes	Yes	Yes
		4	Software Version	13	Yes	No	Yes	No
		5	Temperature Units	13	Yes	Yes	Yes	Yes
		6	Night Setback Temperature	13	Yes	Yes	Yes	Yes
		7	Night Setback Times	13	Yes	Yes	Yes	Yes
TEMPERATURE SETTING	B	1	SH Set Point User	13	Yes	Yes	Yes	Yes
DATA LOGGING	C	1	Hours Running SH	13	Yes	No	Yes	No
		2	Hours Running DHW	13	Yes	No	Yes	No
		3	Ignition Attempts	13	Yes	No	Yes	No
		4	Show Last 10 Errors	13	Yes	No	Yes	No
DHW SETTINGS	E	1	DHW Boiler Set Point	14	Yes	Yes	Yes	Yes
		2	SH/DHW Switching Time	14	Yes	Yes	Yes	Yes
		3	DHW Tank Set Point	14	Yes	Yes	Yes	Yes
OUTDOOR AIR RESET	F	5	Outdoor Air Shutdown	14	Yes	Yes	Yes	Yes
		6	Outdoor Air Shutdown Differential	14	Yes	Yes	Yes	Yes
		8	Boost Temperature	14	Yes	Yes	Yes	Yes
		9	Boost Time	14	Yes	Yes	Yes	Yes

4 SMART SYSTEM control module *(continued)*

A: General

Boiler model

The control will display “Knight Boiler” as the model number because the same control is used on several models. This will be displayed when parameter **A1** has been accessed. This parameter is not changeable.

User code

The User Code allows the user to access and change a limited number of control parameters. The access code can be changed by the user or the installer to a code of their choosing. To change the code, parameter **A2** must be accessed. The default code is 0704. The code can be changed one digit at a time by using the arrow keys on the display.

Date and time

The control uses an internal clock for the night setback feature and for logging of events. For these features to work correctly, the clock must be set when the boiler is first installed or anytime the boiler has been powered off for more than 30 days. To set the clock, parameter **A3** must be accessed. The date and time are displayed as “YY:MM:DD W hh:mm”. YY = year, MM = month, DD = date, W = day (1 = Sunday, 2 = Monday, etc.), hh = hour (24 hour time; 2:00 PM = 14:00), mm = minutes.

NOTICE

The internal clock does not adjust for Daylight Savings Time and therefore, will require a manual adjustment.

Software version

The software version allows the user to view the software version in use by the control. This software controls the operation of the boiler. When a new software version becomes available, the existing control can be replaced with a new control to update the software.

Temperature units

The control can be configured to display temperature in either °C or °F. This parameter can be changed by the user or the installer by accessing parameter **A5**. The default is °F.

Night setback temperature

Once the internal clock has been set correctly, the night setback feature can be used to program a lower water temperature set point for space heating. This parameter can be changed by the user or the installer by accessing parameter **A6**. The temperature range for this parameter is 32°F (0°C) to 140°F (60°C). The feature is turned off with a setting of 32°F (0°C). The default value is 32°F (0°C).

Night setback times

If parameter **A6** is set to anything other than 32°F (0°C), the night setback feature becomes active. This will require start and stop times to be programmed for the days that reduced temperatures are required. These times can be changed by the user or the installer by accessing parameter **A7**. Each day of the week (Sunday through Saturday) will have an on and off time.

Example: Monday ON: 22:30, Tuesday OFF: 6:45. If you wish to skip a day and have no night setback, leave the on and off times the same. The default times for each day will be 00:00 (midnight).

B: Temperature settings

SH set point user

The SH set point user sets the water temperature set point for fixed operation or the maximum temperature set point when the outdoor air sensor is used. This parameter can be changed by the user or the installer by accessing parameter **B1**. The temperature range of this parameter is 50°F (10°) to 190°F (88°C). The default value is 125°F (52°C).

C: Data logging

Hours running SH

The hours running SH parameter shows the total number of hours the boiler has been in the SH firing position. This parameter can be viewed by the user and the installer by accessing parameter **C1**.

Hours running DHW

The hours running DHW parameter shows the total number of hours the boiler has been in the DHW firing position. This parameter can be viewed by the user and the installer by accessing parameter **C2**.

Ignition attempts

The ignition attempts parameter shows the total number of times the boiler has attempted to fire. This parameter can be viewed by the user and the installer by accessing parameter **C3**.

Show last 10 errors

The control will log the 10 most current errors with the date and time the error occurred. This parameter can be viewed by the user and the installer by accessing parameter **C4**.

4 SMART SYSTEM control module

E: DHW settings

DHW boiler set point

When a DHW call for heat becomes active, the control will use the DHW boiler set point to determine the firing rate of the boiler based on the actual water temperature. This parameter can be changed by the installer by accessing parameter **E1**. The temperature range of this parameter is 50°F (10°C) to 190°F (88°C). The default value is 180°F (82°C).

SH/DHW switching time

The SH/DHW switching time parameter sets the length of time the control will stay in DHW Mode when a SH call has been received. After this time period has expired the control will revert to SH Mode. If a DHW call is still active the timer will reset. After the time period has expired the control will revert back to DHW Mode. This will continue until one of the demands has been satisfied. This parameter can be changed by the installer by accessing parameter **E2**. The time range of this parameter is 10 minutes to 240 minutes. The default value is 30 minutes.

DHW tank set point

By installing a tank sensor, the SMART SYSTEM control can perform the tank thermostat function. The SMART SYSTEM control automatically detects the presence of this sensor, and generates a DHW call for heat when the tank temperature drops 6°F (3.5°C) below the tank set point, and finishes the call for heat when the tank temperature goes 4°F (2°C) above the tank set point. This parameter can be changed by the installer by accessing parameter **E3**. The temperature range of this parameter is 32°F (0°C) to 212°F (100°C). The default value is 125°F (52°C).

F: Outdoor air reset

Outdoor air shutdown

When the outdoor temperature rises above this point, the control will block all SH demands (DHW demands will still be active). This parameter can be changed by the user or the installer by accessing parameter **F5**. The temperature range of this parameter is 0°F (-18°C) to 120°F (49°C). The default value is 70°F (21°C).

Outdoor air shutdown differential

The outdoor air shutdown differential parameter is the number of degrees below parameter **F5** the outdoor air temperature must go before the boiler will respond to a SH demand. This parameter can be changed by the user or the installer by accessing parameter **F6**. The temperature range of this parameter is 0°F (0°) to 90°F (50°C). The default value is 10°F (5°C).

Boost temperature

If a SH demand lasts longer than the programmed time delay setting (**F9**) and there have been no DHW demands, the control will increase the water temperature set point by the amount in this parameter. If the SH demand continues through another time period, the set point will be increased again. This will continue until either the SH demand ends, a maximum of 20 increases has occurred, or the maximum set point has been reached. Once the SH demand has been satisfied the set point will revert back to its calculated setting. The boost temperature can be changed by the installer by accessing parameter **F8**. The temperature range of this parameter is 0°F (0°C) to 45°F (25°C). The default value is 0°F (0°C). This feature will be active if this parameter is set to anything other than 0°F (0°C).

Boost time

The boost time parameter sets the amount of time that must elapse with a SH demand before the water temperature set point will be increased. This parameter can be changed by the installer by accessing parameter **F9**. The time range for this parameter is 1 minute to 60 minutes. The default value is 20 minutes.

4 SMART SYSTEM control module *(continued)*

Status Display Screens		
By using the Previous/Next (◀, ▶) arrow keys on the SMART SYSTEM display panel, you can navigate through the eight (8) display screens. Each screen will contain two (2) viewable items. The following is a description of the individual items and what they can display:		
Screen	Display shows:	Description
#1	BLR: OFF	The unit has been turned OFF by the Enter/Reset button on the SMART SYSTEM display panel.
	Standby	The unit has not received a call for heat from a remote thermostat nor has it received a call for heat from a DHW thermostat.
	Set Point Met	The unit has met the water temperature set point, but is still receiving a call for heat from either a remote thermostat or a DHW thermostat.
	Prepurge	The unit has initiated a 10 second purge period on a call for heat. Note: On the 800 model the unit will initiate a 20 second purge period on a call for heat.
	Ignition	The unit has begun a 5 second spark period to ignite the main burner.
	SH***% Rate	The unit has fired and is running at the displayed percentage.
	Postpurge	The call for heat has been satisfied and the unit runs the fan for an additional 10 seconds to clear the combustion chamber and vent system of residual flue products.
	Service	The unit has been placed in a temporary mode that will allow the unit to fire at 100% of rate for the purpose of combustion analysis.
	OUT: ***.*F(***)	When the outlet sensor has been selected as the control sensor (default), the control will display the outlet temperature as well as the set point in parenthesis.
	***.*F	If the outlet sensor has not been selected as the control sensor, only the outlet temperature will be displayed.
	Open	The control does not detect the outlet sensor.
Shorted	The outlet sensor wires or the sensor itself has become shorted.	
Press the Next ▶ arrow key on the SMART SYSTEM display to access Screen #2.		
#2	IN: ***.*F	If the inlet sensor has not been selected as the control sensor, only the inlet temperature will be displayed.
	.*F ()	When the inlet sensor has been selected as the control sensor, the control will display the inlet temperature as well as the set point in parenthesis.
	Open	The control does not detect the inlet sensor.
	Shorted	The inlet sensor wires or the sensor itself has become shorted.
	RISE: ***.*F	The difference between the inlet temperature and the outlet temperature.
Press the Next ▶ arrow key on the SMART SYSTEM display to access Screen #3.		

4 SMART SYSTEM control module

Status Display Screens (cont'd)

By using the Previous/Next (◀, ▶) arrow keys on the SMART SYSTEM display panel, you can navigate through the eight (8) display screens. Each screen will contain two (2) viewable items. The following is a description of the individual items and what they can display:

Screen	Display shows:	Description
#3	SYS: *.*F	If the system supply sensor has not been selected as the control sensor, only the system temperature will be displayed.
	*.*F (***)	When the system supply sensor has been selected as the control sensor, the control will display the system temperature as well as the set point in parenthesis.
	Open	The control does not detect the system supply sensor.
	Shorted	The system supply sensor wires or the sensor itself has become grounded.
	OUTDOOR: *.*F	The control will display the outdoor air temperature as sensed by the outdoor air sensor.
	Open	The control does not detect the outdoor air sensor.
	Shorted	The outdoor air sensor wires or the sensor itself has become shorted.
Press the Next ▶ arrow key on the SMART SYSTEM display to access Screen #4.		
#4	FLUE: *.*F	The control will display the flue temperature.
	Open	The control does not detect the flue sensor.
	Shorted	The flue sensor wires or the sensor itself has become shorted.
	AUX: *.*F	The control will display the temperature.
	Open	The control does not detect the auxiliary sensor.
	Shorted	The auxiliary sensor wires or the sensor itself has become shorted.
Press the Next ▶ arrow key on the SMART SYSTEM display to access Screen #5.		
#5	FAN SPD: ****RPM	The control will display the actual fan motor RPM.
	FLAME SIG: *.*uA	The control will display the flame signal in dc microamps.
Press the Next ▶ arrow key on the SMART SYSTEM display to access Screen #6.		
#6	SH CFH: OFF	The control has not received a call for heat from a remote thermostat.
	ON	The control has received a call for heat from a remote thermostat.
	DHW CFH: OFF	The control has not received a call for heat from a SH remote thermostat.
	ON	The control has received a call for heat from a DHW thermostat.
Press the Next ▶ arrow key on the SMART SYSTEM display to access Screen #7.		

4 SMART SYSTEM control module *(continued)*

Status Display Screens *(cont'd)*

By using the Previous/Next (◀, ▶) arrow keys on the SMART SYSTEM display panel, you can navigate through the eight (8) display screens. Each screen will contain two (2) viewable items. The following is a description of the individual items and what they can display:

Screen	Display shows:	Description
#7	DHW PUMP: OFF	The control has not received a DHW call for heat and has not powered the DHW pump.
	ON	The control has received a DHW call for heat and has powered the DHW pump.
	Delay	The DHW call for heat has been satisfied and the DHW pump is running for a fixed time to remove any residual heat.
	0-10V IN: **.Vdc	The control will display a 0-10Vdc signal received from a Building Management System (BMS) connected to the unit.
Press the Next ▶ arrow key on the SMART SYSTEM display to access Screen #8.		
#8	SYS PUMP: OFF	The control has not received a call for heat from a remote thermostat and has not powered the system pump.
	ON	The control has received a call for heat from a remote thermostat and has powered the system pump.
	Delay	The system call for heat has been satisfied and the system pump is running for a fixed time to remove any residual heat.
	BLR PUMP: OFF	The control has either not received a call for heat from a remote thermostat, a remote thermostat is not connected to the unit and the water temperature has not dropped below the temperature set point of the control to initiate a call for heat, or the control has received a DHW call for heat from a DHW thermostat.
	ON	The control has received a call for heat from a remote thermostat or a remote thermostat is not connected and the water temperature has dropped below the temperature set point of the control to initiate a call for heat.
	Delay	The call for heat has been satisfied and the boiler pump is running for a fixed time to remove any residual heat.
Press the Next ▶ arrow key on the SMART SYSTEM display to access Screen #9.		

4 SMART SYSTEM control module

Status Display Screens (cont'd)

Operation of the cascade

The boiler designated as the Leader will have two additional display screens that can be viewed. These screens will provide information regarding the operation of the Cascade. Each screen will contain two viewable items. The following is a description of the individual items and what they can display:

Screen	Display shows:	Description
#9	Cas: Off	The Leader control has been turned off by the Enter/Reset button on the Smart System display.
	Cas: Standby	The Leader boiler has not received a call for heat from a remote thermostat.
	Cas: 127.4F (130)	The Cascade is now active. The system supply temperature will be displayed. The Cascade set point will be displayed in parenthesis.
	Cas: Setpoint Met	The Cascade has met the water temperature set point, but is still receiving a call for heat from a remote thermostat.
	Cas: No Members	The Leader control could not detect any Member controls to participate in the Cascade.
	Cas: S6 Not Present	The system supply sensor is not connected to the Leader boiler.
	PMP: Off	The Leader control has not received a call for heat from a remote thermostat and has not powered the system pump.
	PMP: On	The Leader control has received a call for heat from a remote thermostat and has powered the system pump.
	PMP: Delay	The system call for heat has been satisfied and the system pump is running for a fixed time to remove any residual heat.

Press the Next ► arrow key on the SMART SYSTEM display to access Screen #10.

#10	Cas Pow: ***% ***%	The first percentage shows the firing rate that is being sent to the last boiler called on. The second percentage shows the total power available to the Cascade.
	Present: 01234567 Example: Present: 23----d1	Shows the number of boilers connected to the Cascade. The Leader is designated as 0. Members will be designated 1 - 7. If a “-“ is used in place of a number, that boiler is either not connected, or in a lockout mode and not available for the Cascade. If a “d” is used in place of a number, that boiler is handling a DHW demand and is not available for the Cascade. If the number is flashing, then that boiler is providing heat to the Cascade. As the lead boiler is changed from day to day, that boiler's address will be shown first in the string of numbers. In the example, boilers 0 - 3 are present, boiler 2 is the lead boiler, and boiler 0 is heating an indirect DHW tank.

Press the Next ► arrow key on the SMART SYSTEM display to roll back to Screen #1. At any point if you wish to access an earlier screen, press the Previous ◀ arrow key on the SMART SYSTEM display.

Notes

Revision Notes: *Revision B (KBX-USER-Rev B) reflects changes made to the "Check Air Piping" section on page 6.*

Revision C (ECO #C02545) reflects the addition of references to periodic cleaning of screens in vent terminations.