

400 WATT WIND TURBINE



User's Manual

Ver.2013.10.1

Table of Content

1. SAFETY.....	3
1.1 Mechanical Hazard	3
1.2 Electrical Hazard.....	3
2. MODEL AND SPECIFICATION TABLE.....	4
2.1 Specification Table	4
2.2 Performance specifications.....	5
2.3 System protection	5
3. PACKAGE CONTENTS.....	6
3.1 Parts List.....	6
3.2 System Wiring Diagrams	7
4. INSTALLATION PROCEDURE	11
5. MAINTENANCE	13
6. FAQs	13
8. TROUBLESHOOTING.....	15
9. WARRANTY	16
APPENDIX A IMPORTANT SAFETY INSTRUCTIONS.....	18
APPENDIX B BEAUFORT WIND SCALE.....	19
APPENDIX C RECOMMENDED WIRE GAUGE.....	20
APPENDIX D REGISTRATION FORM.....	21

1. SAFETY

Your 400 Watt Wind Turbine is designed with your personal safety as the first priority. However, there are still some inherent dangers involved with any electrical and/or mechanical equipment.

Safety must be the primary concern as you plan the location, installation and operation of the turbine. Please read the following:

Important Safety Instructions

Please take the time to read through this manual prior to assembly.

- 1) Place this instruction manual in a safe place for reference.
- 2) Wait until a calm day to install or perform maintenance on your Turbine.
- 3) Listen to your Turbine should you hear any mechanical noise, maintenance may be required, please contact The Customer Service.
- 4) After installation re-adjust and tighten the screws and bolts.
- 5) Adhere to proper grounding techniques as established by the NEC.
- 6) Your Wind Turbine must be installed in accordance with this manual and local and national building code. Incorrect installation may void your warranty.
- 7) Wind turbine blades spin at a potentially dangerous speed this must be respected. Never approach a turbine in motion.
- 8) Note wire size (gauge chart included) prior to wiring. Any under sizing of wire can be potentially dangerous.

1.1 Mechanical Hazard

Rotating blades present the most serious mechanical hazard. The rotor blades are made of very strong thermoplastic. At the tip, the blades may be moving at velocities over 15 m/s. At this speed, the tip of a blade is nearly invisible and can cause serious injury. Under no circumstances should you install the turbine where a person could come in contact with moving rotor blades.

1.2 Electrical Hazard

The 400W Turbine is equipped with sophisticated electronics designed to provide protection from electrical dangers. Please note that the inherent personal dangers from electrical current still exist, therefore caution should always be used when connecting this and other electrical devices. Heat in a wiring system is often a result of too much current flowing through an undersized wire or through a bad connection. Please consult wire guide table below. Batteries can deliver a dangerous amount of current. If a short circuit occurs in the wiring from the batteries, a fire can result. In order to avoid this threat, a properly sized fuse or circuit breaker is required in the lines connecting to the battery.

Choosing your 400 Watt Wind Turbine's location

Prior to the mounting of your 400 Watt Wind Turbine, you must carefully consider a location.

Things to consider when thinking about your location

- A) Distance from any obstacles that will cause turbulence, trees, buildings etc.
- B) Distance from Wind Turbine and battery bank
- C) Any local zoning restrictions
- D) Clearance of power lines

In general terms the higher the tower the less obstruction to air flow, leading to a more efficient charge capacity. The minimum recommended tower height is 30ft or 20ft above nearby obstructions as shown below.

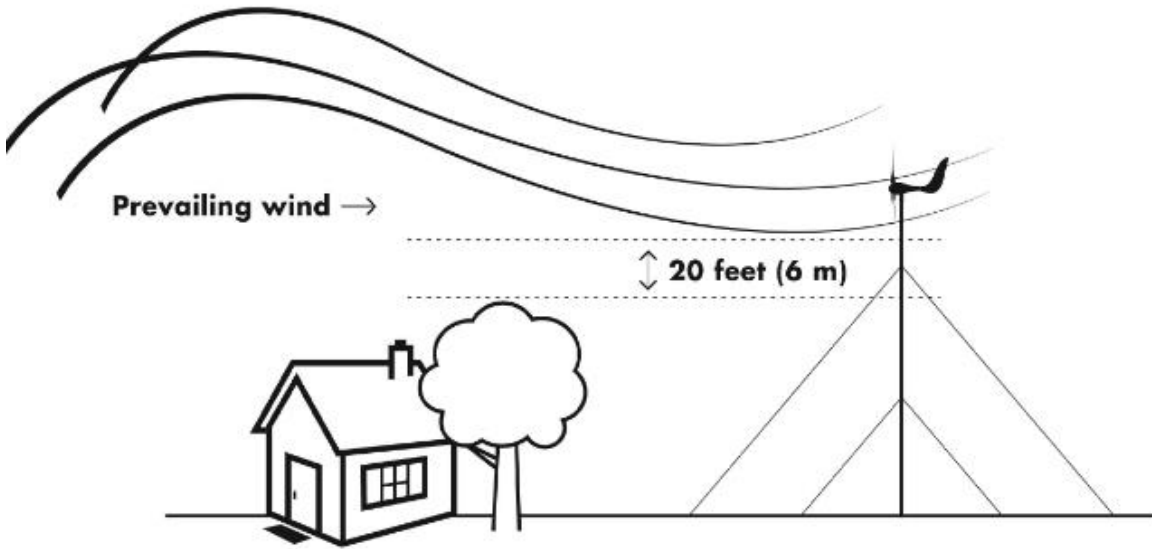

2. MODEL AND SPECIFICATION TABLE

2.1 Specification Table

Model	400W Turbine
Rated speed	14 m/s (46 ft/s)
Rated power	400W
*Output Voltage	0-15V
Rotor diameter	1.22m (4ft)
Cut-in wind speed	3 m/s (6.7 MPH)
**Survival wind speed	50 m/s (110 MPH)
Number of Blades	3
Blade material	Plastic steel
Suggested battery capacity	>50 A/Hr

***For the 400W turbine that operates on 0-15V output voltage, we highly recommend using 12 AWG wire and maintaining a distance of 20m (66ft) between turbine and the battery. Using inappropriate wire gauge will result in a drastic increase in voltage.**

****Please activate the brake manually when the wind speed exceeds 30 MPH (48 KM/H). The survival wind speed means the turbine can survive 110 MPH (180 KM/H) when the brake is manually activated. Exceeding this stated wind speed will result in wind turbine failure and collapse.**

2.2 Performance specifications

The following power curve shows the performance you should expect from your wind turbine. During smooth, steady wind speed, you can expect to see output resembling the curve illustrated below. To convert between power and current use the following formula:

$$\text{POWER} = \text{VOLTAGE} \times \text{AMPS}$$

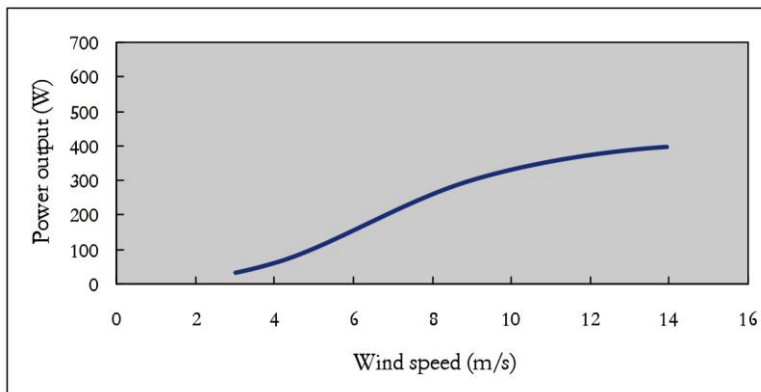

2.3 System protection

Your turbine comes equipped with state of the art overcharge protection. When the temperature of the turbine exceeds 80° C (176° F) your turbine will automatically shut down and apply the braking system to your Wind Turbine to prevent damage.

High battery voltage protection	14.8V
Over charging current protection	20A
Over-speed protection	≤ 1200 rpm
Overheat protection for generator	≥ 900 rpm and 70 sec.

Caution 1: Any under sizing of wire can be potentially dangerous; our warranty doesn't cover damage caused by improper use of wire gauge.

Caution 2: Please review the following wire gauge table to install the correct wire gauge.

We recommend these as the minimum wire sizes for optimal performance for the distance from your turbine to the battery. Always use the largest gauge wires that are practical and affordable. Local, state, and or national electrical codes take precedence over these general recommendations.

12V Volt Systems, AWG / Metric Wire Size mm²

0-10M	10-20M	20-30M	30-45M	45-75M	75-120M
14 / 2 mm ²	12 / 3.5 mm ²	10 / 5.5 mm ²	8 / 8 mm ²	6 / 14 mm ²	4 / 22 mm ²

3. PACKAGE CONTENTS

Check the parts listed with the contents of the box and make sure that you have everything needed for assembly.

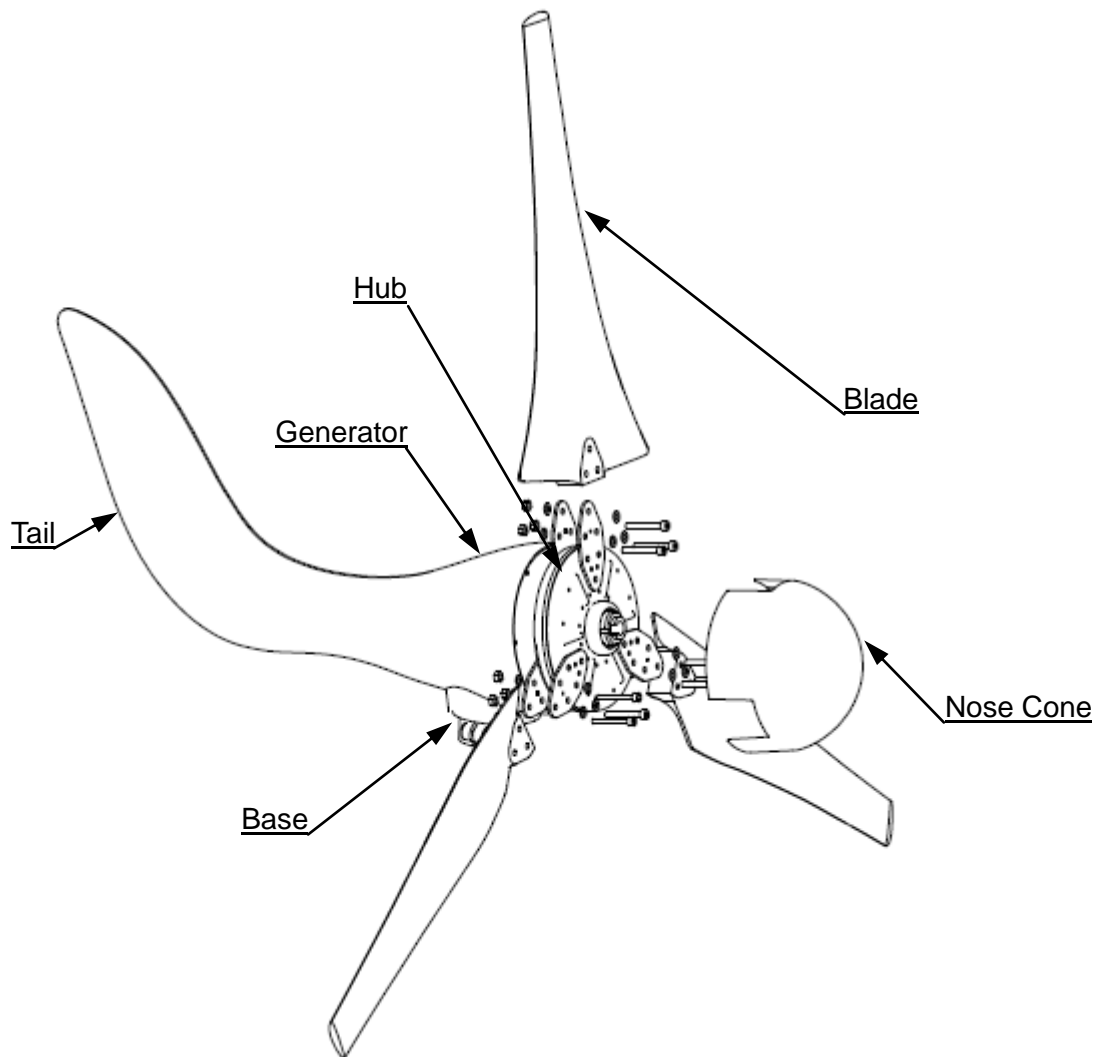

Caution: The edges of the blades are sharp. Please handle with care.

3.1 Parts List

Name	Quantity	
Generator (integrated with Tail and Hub)	1	
Blade	3	
Nose Cone	1	
Accessory Pack	Hex Screw (M6XL45)	9
	Nut (M6)	11
	Washer (M6)	20
	Hex Screw (M6XL30)	2
	Hex Key No.5	1
	10mm Unilateral opening wrench	1

3.2 System Wiring Diagrams

There are multiple options to connect your Wind Turbine dependent on your power requirements and available components.

Single Turbine installation:

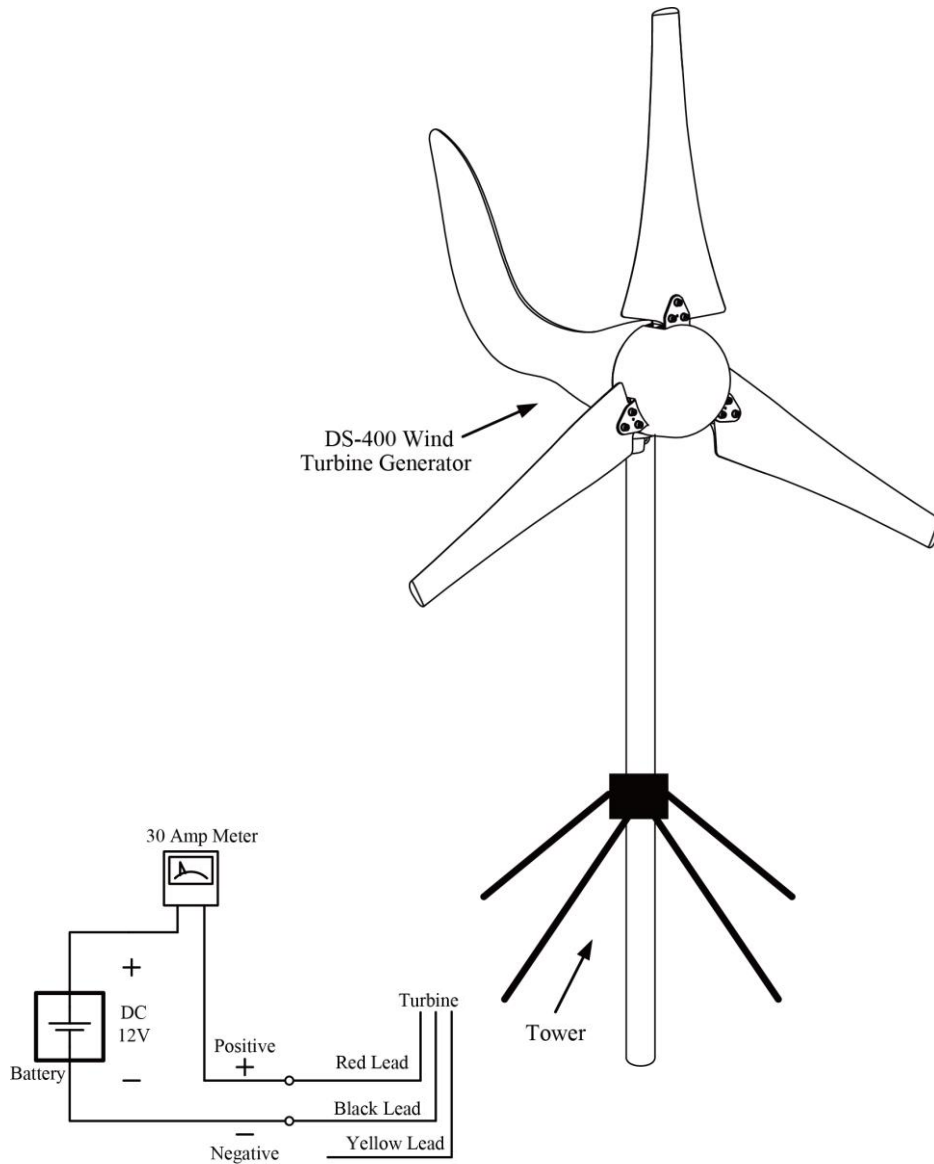

NOTE: Please refer to the recommended wire gauge table and select the appropriate wire size for your system.

Multiple Turbine installation:

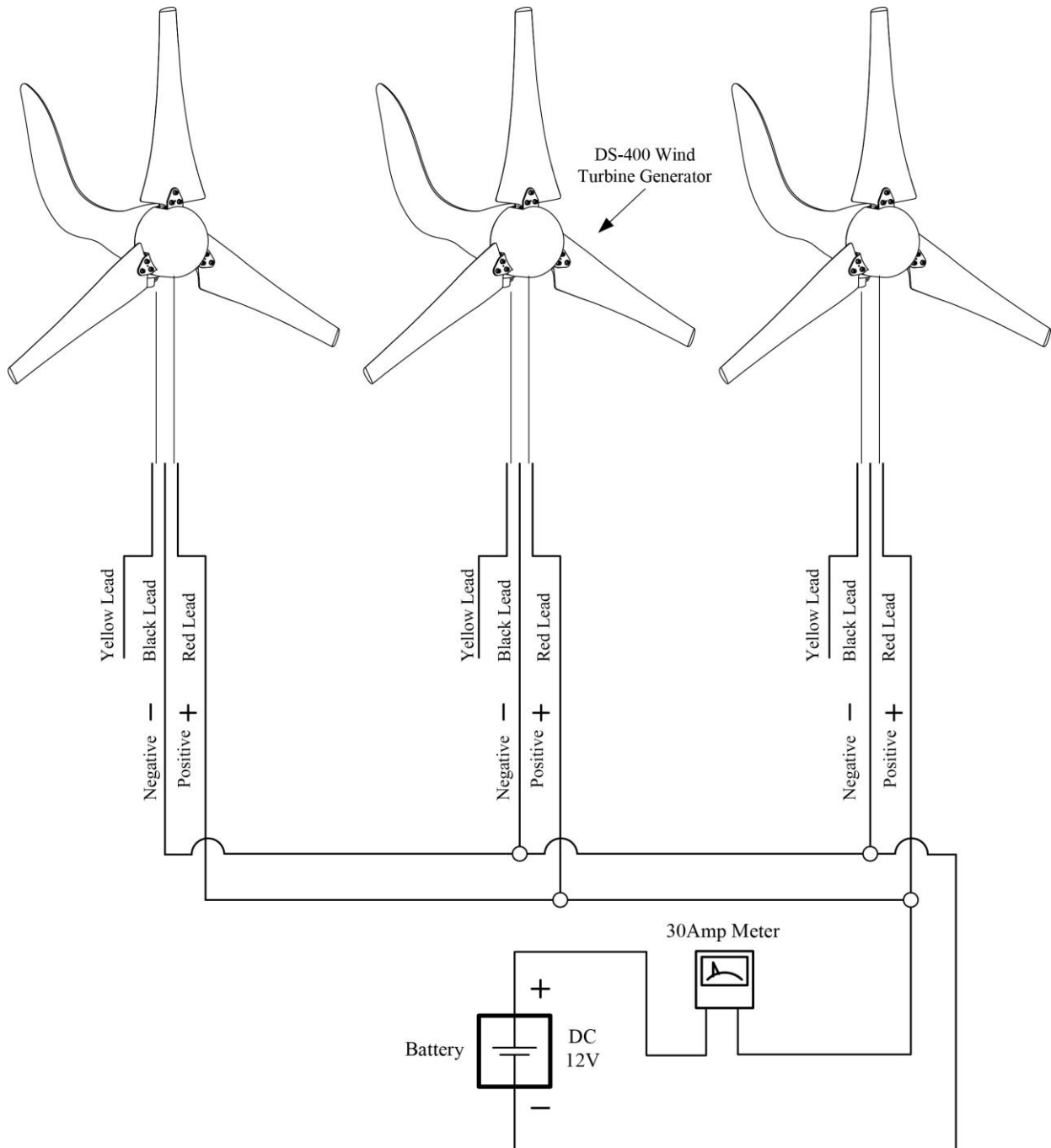

NOTE: Please refer to the recommended wire gauge table and select the appropriate wire size for your system.

Hybrid Solar/Wind System

A typical “hybrid” system (Photovoltaic and Wind combined) is wired as follows, whenever feasible wire the turbine and solar panels to their own set of battery terminals.

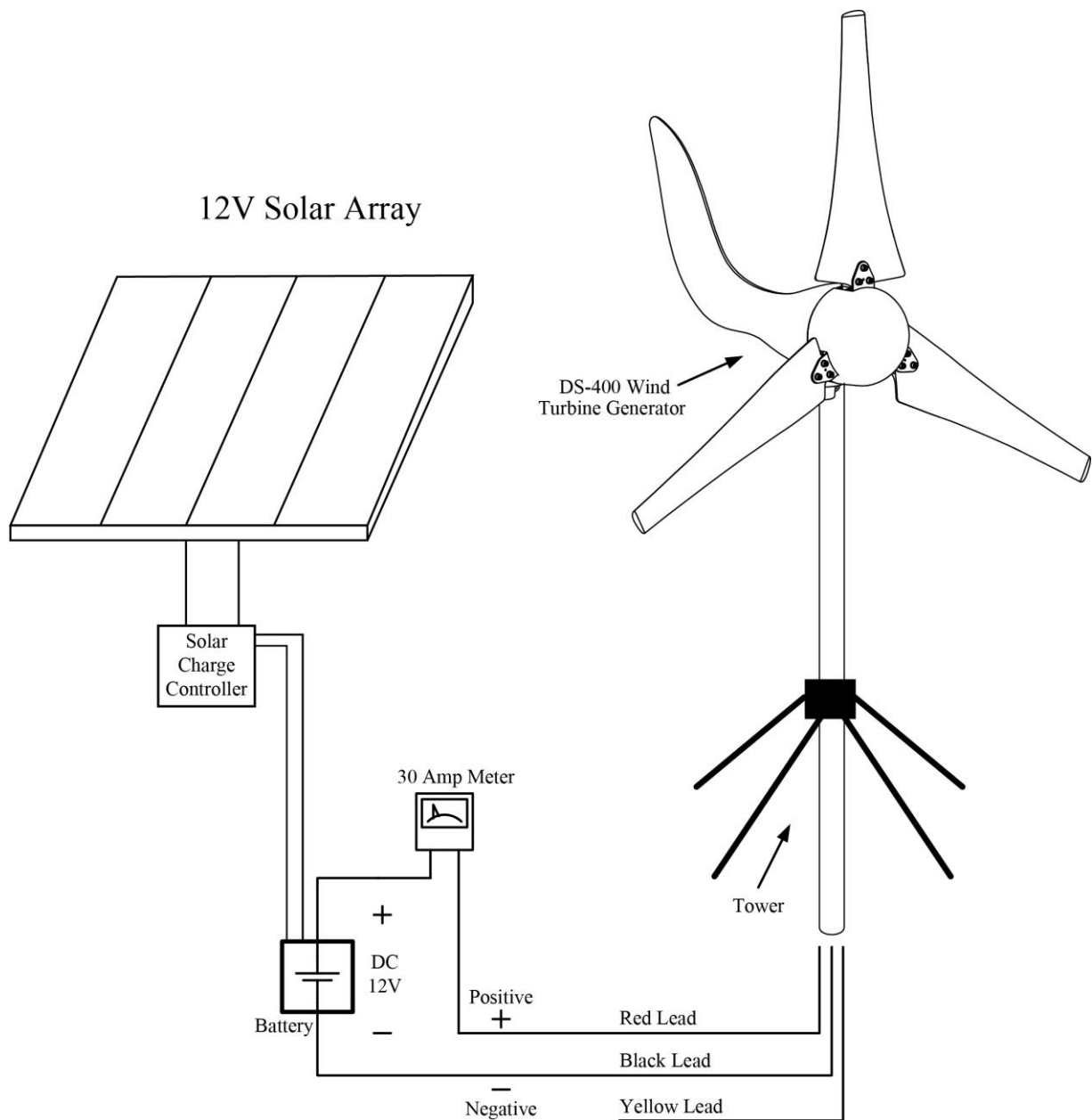

NOTE: Please refer to the recommended wire gauge table and select the appropriate wire size for your system.

IMPORTANT: Please activate the brake manually during the period of high winds or any extreme conditions.

How to manually activate the brake:

Normal operation

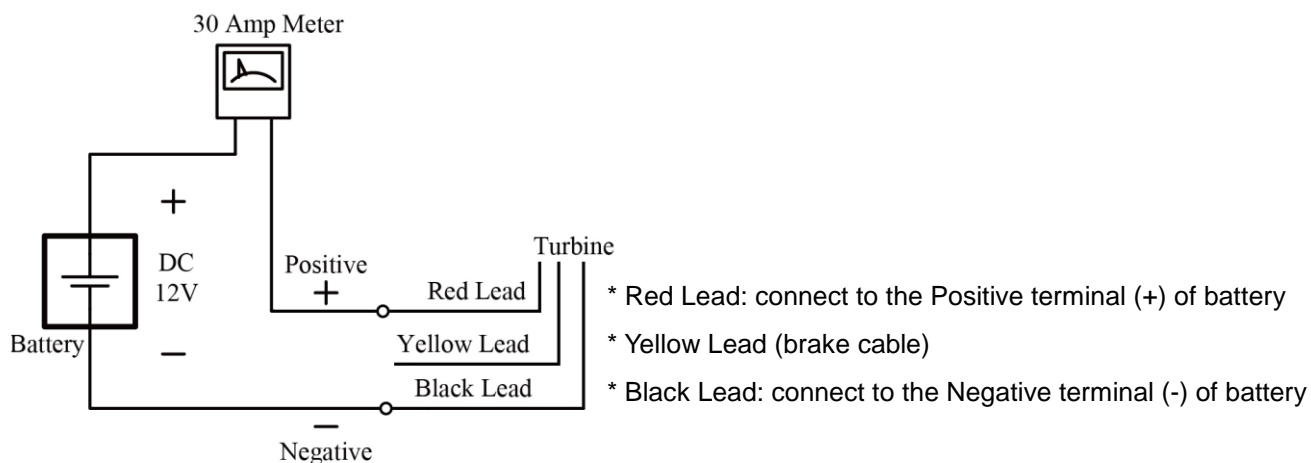

Step 1 Disconnect the Red lead from the positive terminal of a battery.

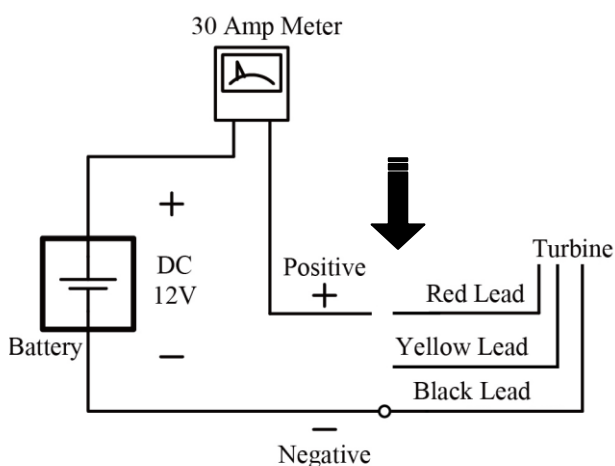

Step 2 Connect the Red lead to the Yellow lead. The turbine should be stopped immediately.

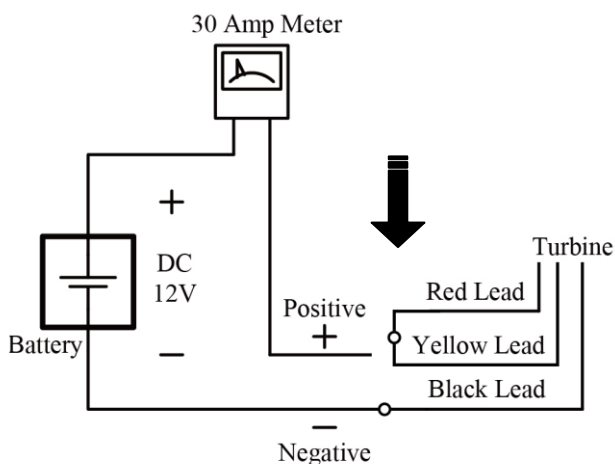



WARNING: Disconnect the Red lead from the battery before connecting to the Yellow lead.

Improper connection might damage your wind turbine and cause dangers.

4. INSTALLATION PROCEDURE

Step 1 : Open box and ensure all parts are present.

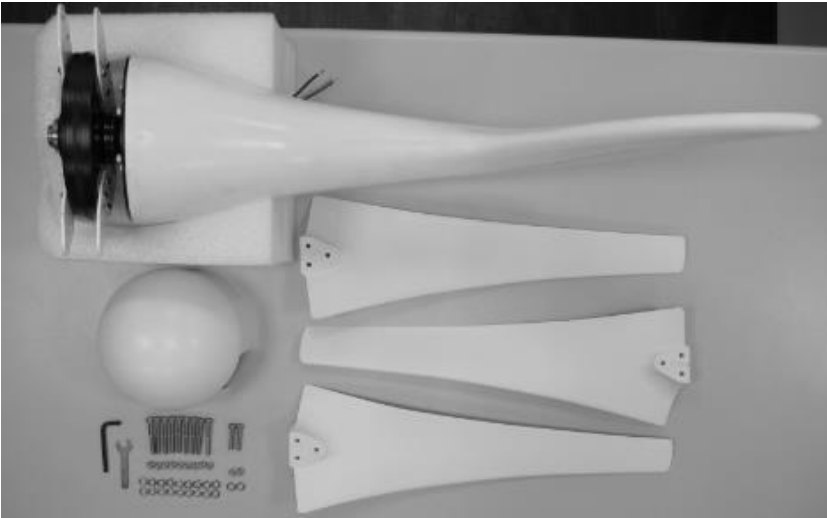

Step 2 : Install the wind turbine to your chosen tower (not included) and fasten the bolt securely by using the hex key (The Yaw Shaft includes a rubber space to ensure the connection is secure).

Caution: Owing to the base of the Turbine, the outside diameter of the iron pipe should be 48.3mm to 48.6mm and the wall thickness should be 1.9mm at least.



Step 3 : Fasten the blades on the hub with nuts by using the hex key and unilateral opening wrench. (Make sure that all of the bolts are secured with nuts.)





Step 4 : Fit the nose cone onto the hub properly.

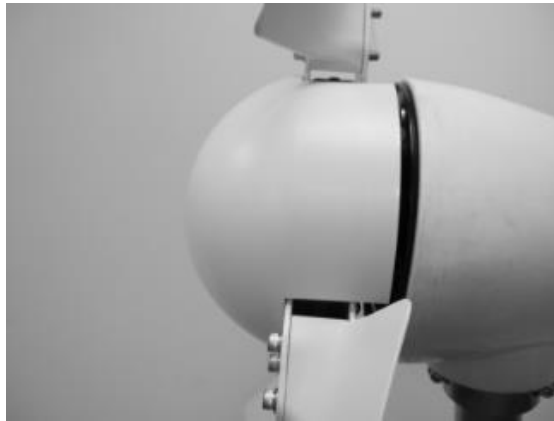
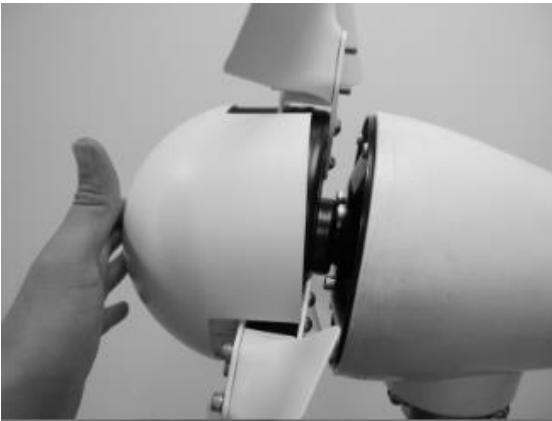

Step 5 : Final product diagram



5. MAINTENANCE

Your 400 Watt Wind Turbine has been designed to run for long periods without requiring any maintenance. Performance will be enhanced if you periodically inspect your system.

Review the following simple maintenance procedures and implement every six months.

Caution 1: Do not go near the wind turbine during operation.

Caution 2: The blades are sharp. Please handle with care.

- Check blades for superficial damage. Replace blades if damaged. It is important to not use blades that are damaged, as you will lose overall balance, resulting in a decrease in efficiency. Should you notice damage to the blades you must replace all 3. The blades are balanced as sets.
- Check the blade bolts and the hub nut for tightness.
- Check nosecone for cracks and tighten nuts.
- Wipe any excess dirt build-up from the blades.
- Check all electrical connections to make sure they are tight and free from corrosion.
- Check the voltage of your battery bank with a Multi-meter and clean the terminals.
- We suggest replacing the blades every five years for optimal performance.

6. FAQs

(1) How does the 400 Watt Wind Turbine control power and RPM in high winds?

Your Turbine's operation will be halted to reduce the risk of damage due to overcharge and over spin of the rotor blades. This process of braking is handled internally through your Turbines electronics.

(2) What is the maximum wind speed the 400 Watt Wind Turbine will survive, and do I need to take it down in a storm? Your wind turbine is designed to operate in most climatic conditions. Should you expect or experience winds of 110 MPH upwards, please manually activate the brake. Once the Turbine has stopped it is possible to lay down the Tower to offer further protection.

(3) How long will the bearings or other wearing parts last?

According to engineering calculations, the bearings should have a 10-year life span in 12 mph (6 m/s) average wind speed sites. Bearing life will vary from one application to another; however, you should expect at least a five-year performance in adverse conditions and 10 years in normal conditions.

(4) Can the 400 Watt Wind Turbine be connected in reverse-polarity to the battery without causing any damage?

Reverse polarity will cause damage to your battery if not quickly remedied. Always double check any wiring to reduce the risk of reverse polarity. Your turbine is equipped with polarity protection to reduce the risk of damage, but it is still possible to degrade your wiring and cause damage to the overall system.

(5) Will it hurt my 400 Watt Wind Turbine to short-circuit the output?

No, the 400 Watt Wind Turbine is designed to be short-circuited as a normal shutdown procedure by a fuse. The function of the stop switch is to both disconnect the turbine from the batteries as well as short-circuit the output of the turbine.

(6) Where can I locate tubing to make a tower?

Your 400 Watt Wind Turbine is designed to make mounting as simple and straightforward as possible. Should you not wish to purchase the custom tower kit feel free to utilize schedule 40 1.5 inch steel tubing. This should be available through your local hardware outlet.

(7) What is the difference between copper and aluminum wire?

Generally aluminum wire is less conductive, so it must be bigger for the same amp load and resistive losses as copper. The 400 Watt Wind Turbine uses copper or tinned copper for the yaw wires.

(8) What battery should I choose for my 400 Watt Wind Turbine?

There are multiple battery options in today's market– flooded lead acid, absorbed Glass mat (AGM), gel cell and NiCad. There is no definitive choice for your alternative energy needs. Normally the choice of battery is determined by availability and pricing. Should you have questions regarding batteries please consult a local battery supplier. Or view: www.batterycouncil.org. The capacity of your battery bank is determined by your use. Below is a good guideline.

- 12-volt systems – 400 Amp-hours

Possible Battery Configurations (suggested)

12V VOLT BATTERIES IN PARALLEL

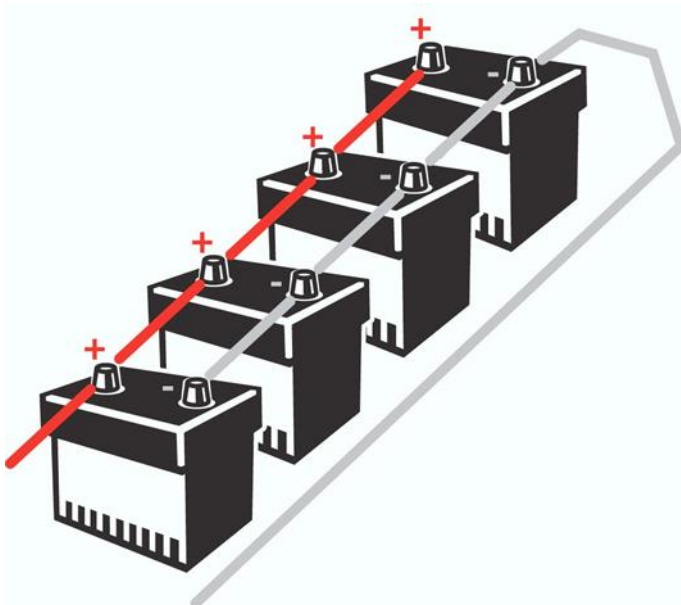

(9) Is lightning protection necessary?

You should ground your 400 Watt Wind Turbine. Proper grounding (illustrated below) provides protection to individuals and equipment by eliminating the possibility of dangerous voltage. Remember a steel tower is a conduit for lightning.

Every wind turbine and turbine tower needs to be grounded at the tower base even though the system may be grounded at the battery bank. Grounding the tower at its base may help prevent shocks to persons touching the tower due to lightning or electrical faults. Please take the time to review the National Electrical Code (NEC) and local building and zoning regulations for complete requirements. Even in "Off Grid Systems" there are multiple ways for tower grounding, the most common method is a copper clad steel electrode(s) driven into the soil. Please view the following grounding diagram.

(10) What effect does radio interference have on my 400 Watt Wind Turbine?

The internal circuitry of the 400 Watt Wind Turbine is shielded and filtered to prevent radio interference, and has been tested to insure electro-magnetic compatibility.

(11) What effect does my 400 Watt Wind Turbine have on radio transmissions?

The 400 Watt Wind Turbine normally does not affect radio transmitters. Care should be taken, however, to route power lines from the 400 Watt Wind Turbine away from the power and antenna lines of a radio transmitter. An old ham radio operator's trick is to twist positive and negative wires together to provide an even distribution of EMF noise across both wires, which serves to cancel out the electrical noise created.

8. TROUBLESHOOTING

You may require an extra person to assist with these tests.

- (1) Remove the blade/hub from the turbine. Replace the rotor hub nut on the rotor shaft.
- (2) Quickly spin the rotor shaft manually with your fingers while connecting and disconnecting the red and yellow wires (turbine must not be connected to batteries).
- (3) With the red and yellow wires connected to each other, the shaft should be more difficult to turn. When the wires are disconnected it should spin freely. Should this not be true please contact supplier or manufacturer.
- (4) With your 400 Watt Wind Turbine connected to your battery bank, use an electric hand drill to spin the rotor shaft.
- (5) Below 300 RPM, the rotor should spin freely without friction.
- (6) At 300 RPM and above, the Wind Turbine should be charging the battery. You should feel resistance on the rotor shaft if the shaft is not rotating; contact your turbine dealer or manufacturer. Be aware your battery banks needs to be under 12V for this testing as the Turbine needs to read a charge.

9. WARRANTY

We warrant your product to be free from defects in material and/or workmanship for a period of 1 year from original date of purchase. Warranty coverage is extended only to customer (original purchaser). If product proves defective during warranty period, the manufacturer, at its option will:

1. Replace Wind Turbine with new or refurbished product.
2. Correct reported problem

Customers warranty continues to be valid on repaired or replaced product from original warranty date.

Restrictions

This warranty covers defects in manufacturing discovered while using the product as recommended by the manufacturer. The warranty does not apply to a) equipment, materials, or supplies not manufactured by the manufacturer. b) Product that has been modified or altered by other than manufacturer or without manufacturers prior written approval c) Has been exposed to winds exceeding 134 MPH d) Windstorms, lightning and Hail damage e) Repairs performed by other than authorized support staff. f) All acts of God; misuse, negligence or accidents. g) Tower foundation and wire has not been installed, operated, repaired or maintained in accordance with the instructions supplied by manufacturer. Any service identified in the above list or product is found not to have any defect in manufacturers' workmanship or materials the customer will be responsible for the costs of all repairs and expenses incurred by the manufacturer.

Disclaimer

EXCEPT FOR THE EXPRESSED WARRANTY SET FORTH ABOVE, THE MANUFACTURER DISCLAIMS ALL OTHER EXPRESSED AND IMPLIED WARRANTIES, INCLUDING THE IMPLIED WARRANTIES OR FITNESS FOR A PARTICULAR PURPOSE, MERCHANTABILITY AND NON-INFRINGEMENT. NO OTHER WARRANTY, EXPRESSED OR IMPLIED, WHETHER OR NOT SIMILAR IN NATURE TO ANY OTHER WARRANTY PROVIDED HEREIN, SHALL EXIST WITH RESPECT TO THE PRODUCT SOLD UNDER THE PROVISIONS OF THESE TERMS AND CONDITIONS. THE MANUFACTURER EXPRESSLY DISCLAIMS ALL LIABILITY FOR BODILY INJURIES OR DEATH THAT MAY OCCUR, DIRECTLY OR INDIRECTLY, BY USE OF THE PRODUCT BY ANY PERSON. ALL OTHER WARRANTIES ARE EXPRESSLY WAIVED BY THE CUSTOMER.

Warranty Claims & Return Policies

To be eligible for service under this warranty, customer must either contact manufacturer either through written request or by telephone to submit a service request for the Wind Turbine covered by this warranty within specified period (1 year from original date of purchase) and request a return authorization (RA) number, This RA # must be issued before any product can be returned.

All notifications must include the following information:

- a) Description of alleged defect
- b) How the Wind Turbine was being used

- c) Serial #
- d) The original purchase date
- e) Name, phone #, address of party requesting warranty

Within 2 to 3 business days the manufacturer will provide the customer with an RA# and will direct customer to location where the product is to be returned. Once an RA has been issued the customer has 30 days to return the product. Failure to deliver the product within the 30 days results in the RA as no longer being valid and a new RA must be issued. Manufacturer is under no obligation to accept any product that is returned to them without a proper RA #.

Limitation of Liability

UNDER NO CIRCUMSTANCES WILL THE MANUFACTURER OR ITS AFFILIATES OR SUPPLIERS BE LIABLE OR RESPONSIBLE FOR ANY LOSS OF USE, INTERRUPTION OF BUSINESS, LOST PROFITS, LOST DATA, OR INDIRECT, SPECIAL, INCIDENTAL, OR CONSEQUENTIAL DAMAGES OF ANY KIND REGARDLESS OF THE FORM OF ACTION, WHETHER IN CONTRACT, TORT (INCLUDING NEGLIGENCE), STRICT LIABILITY OR OTHERWISE, RESULTING FROM THE DEFECT, REPAIR, REPLACEMENT, SHIPMENT OR OTHERWISE, EVEN IF THE MANUFACTURER OR ITS AFFILIATE OR SUPPLIER HAS BEEN ADVISED OF THE POSSIBILITY OF SUCH DAMAGE.

APPENDIX A IMPORTANT SAFETY INSTRUCTIONS

Read these instructions below before installing your Wind Turbine to ensure people and property against accidents. Please also make sure it is set up under environmental and operating conditions.

1. Locate your Wind Turbine in windy sites so as not to disturb neighbors and animals around. The noise and vibration element cannot be got rid of even if Sunforce Wind Turbine offers the lowest noise than any others on the market. The better location of your Wind Turbine requires avoiding personnel or animal activities within a 33 ft (10 m) radius, and human habitation and wildlife within a 66 ft (20 m) radius.
2. The height of installation should be 22 ft (7 m) to 33 ft (10 m). The wind speed below 22 ft (7 m) constrained by the terrain is low and chaotic.

For example: If winds in your area are more than 30 mph (13.4 m/s), the height of 7 m is recommended. The higher the Wind Turbine stands (more than 10 m), the much stress your pole kit will sustain. Also, the Wind Turbine possibly brakes in extreme weather conditions.

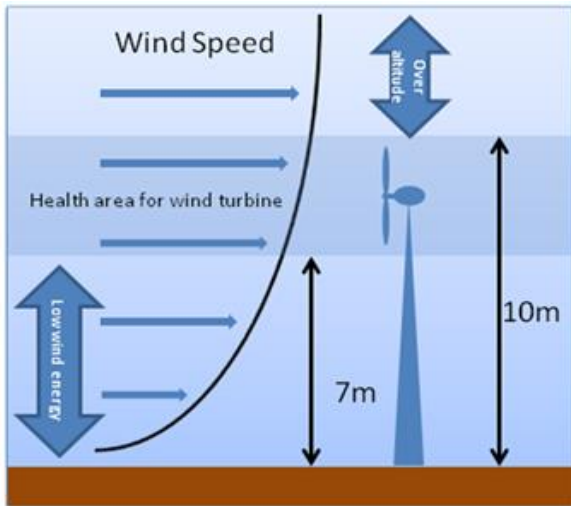













Operating Environment:

- A. Operating Temperature: -4°F (-20°C) ~ 122°F (50°C)
- B. Operating Humidity: < 80%
- C. Average Wind Speed: < 34MPH (<15 m/s or <54KMH)
- D. Max. Peak Wind Speed: < 45MPH (<20m/s or <70KMH)
- E. Elevation: < 1000m
- F. Applicable Installation Height: 8.85ft~33ft (2.7m~10m)

It is subject to IEC 61400-2 safety standards. If the operating temperature and wind speed exceed the above-mentioned limits, turn on the manual brake in proper way to shut off the Turbine.

3. The rooftop may not be the best place for your Wind Turbine. Here are three reasons.
 - a. The flow is more turbulent above the rooftop and leads to the low wind power availability.
 - b. The stress the pole kit sustains varies in rooftop constructions. The evaluation and stability cannot be guaranteed.
 - c. The slight noise and vibration still affect sleep for some sensitive people and animals.
4. Check the battery health periodically. The abnormal battery and improper connection will cause over-spin issues. The Wind Turbine's operation should be halted to reduce the risk of damage due to over spin of the rotor blades.
5. Survival wind speed means that the wind turbine will survive 110 MPH (180 KMH) when the brake is manually activated. Exceeding this stated wind speed will result in wind turbine failure and collapse.
6. Reverse polarity will cause damage to your battery if not quickly remedied. Your turbine is equipped with polarity protection (a beeper) to reduce the risk of damage. Please check the wiring for polarity if you hear a beep sound after installation.

APPENDIX B BEAUFORT WIND SCALE

Beaufort No.	Description	Avg. Wind Speed (knot/h)	Avg. Wind Speed (km/h)	Avg. Wind Speed (m/s)	Avg. Wind Speed (mi/h)	Image
0	Calm	< 1	< 2	< 0.55	< 1.24	
1	Light air	1 - 3	2 - 6	0.55~1.66	1.24~3.73	
2	Light breeze	4 - 6	7 - 12	1.95~3.33	4.35~7.46	
3	Gentle breeze	7 - 10	13 - 19	3.61~5.27	8.08~11.81	
4	Moderate breeze	11 - 16	20 - 30	5.55~8.33	12.43~18.64	
5	Fresh breeze	17 - 21	31 - 40	8.61~11.11	19.26~24.85	
6	Strong breeze	22 - 27	41 - 51	11.38~14.16	25.48~31.69	
7	Moderate gale	28 - 33	52 - 62	14.45~17.22	32.31~38.53	
8	Fresh gale	34 - 40	63 - 75	17.5~20.83	39.15~46.60	
9	Strong gale	41 - 47	76 - 87	21.11~24.16	47.22~54.06	
10	Storm	48 - 55	88 - 103	24.44~28.61	54.68~64.00	
11	Violent storm	56 - 63	104 - 117	28.88~32.5	64.62~72.70	
12	Hurricane	≥ 64	≥ 118	> 32.77	> 73.32	

*It is strongly advised to manually activate the brake during periods of high winds (upwards of Beaufort Wind Scale 7). Please refer to **3.2 System Wiring Diagrams** for detailed information.

APPENDIX C RECOMMENDED WIRE GAUGE

To determine the wire size, measure the distance from your turbine to the battery. Be sure to include height of the tower.

A. Distance :

System Voltage	AWG / Metric Wire Size (mm ²)
12V	14 / 2 mm ²

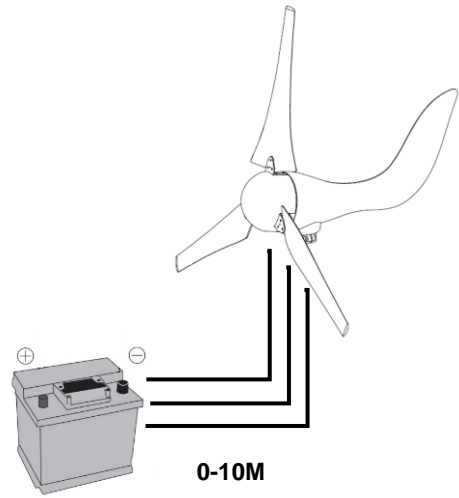

B. Distance:

System Voltage	AWG / Metric Wire Size (mm ²)
12V	12 / 3.5 mm ²

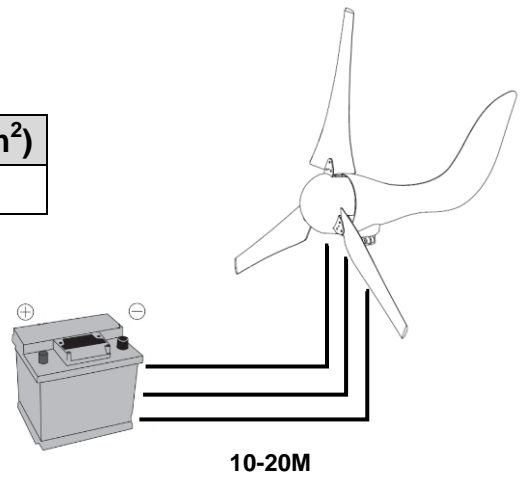

C. Distance:

System Voltage	AWG / Metric Wire Size (mm ²)
12V	10 / 5.5 mm ²

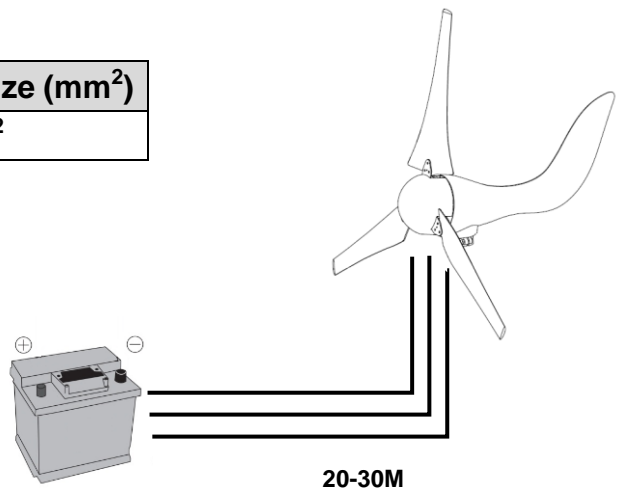

APPENDIX D REGISTRATION FORM

	Registration Form
--	--------------------------

RA No.: _____

Serial No.:	Date:
Event Date:	Location:

Please fill out the following questions for further investigation.

1. The wire used between the wind turbine and the battery: _____ AWG or metric wire size
_____ mm²

2. The interval between the wind turbine and the battery: _____ ft or _____ m

3. The battery capacity: _____ A/Hr

Photo (If applicable)