



Technical Information

PLUS+1[®] Mobile Machine Displays DP2XX Series



Revision history*Table of revisions*

Date	Changed	Rev
May 2014	Converted to Danfoss layout-DITA CMS; Various updates	BA
March 2010	First edition	AA

Contents
DP2XX literature references

Technical Information (TI).....	4
Data Sheet (DS).....	4
API Specifications (API).....	4
PLUS+1® GUIDE Software User Manual.....	4
Latest version of technical literature.....	4

User liability and safety statements

OEM responsibility.....	5
-------------------------	---

DP2XX overview

PLUS+1® Mobile Machine Displays.....	6
Product naming convention.....	6

DP2XX model variants

DP200 model variants.....	8
DP210 model variants—discontinued article.....	8
DP211 model variants.....	9
DP250 model variants.....	10
Related products.....	11

DP2XX connectors

DP200 connectors.....	13
DP210 and DP211 connectors.....	13
DP250 connectors.....	14

DP2XX input/output types and specifications

Input types.....	17
Low level digital/analog inputs.....	17
High digital/analog inputs.....	18
Low level multifunction inputs.....	18
High level multifunction inputs.....	19
Multifunction input ranges.....	20
CAN Shield and analog (5 V only) inputs ranges.....	21
Alarm output.....	21
CAN/RedCAN communication.....	21

DP2XX ratings

Electronic components environmental testing criteria.....	23
Supply voltage/maximum current ratings.....	23
Ingress Protection (IP) rating	25

DP2XX installation and start-up

Dimensions.....	26
Mounting.....	26
Fastening.....	28
Display operation guidelines.....	29
Recommended machine wiring guidelines.....	29
Electronic components welding guidelines.....	29
Limiting crosstalk.....	30
Visibility and viewing radius.....	30
Display faulty application recovery.....	30

DP2XX literature references*Reference literature*

Literature title	Literature type	Literature number
DP2XX Series PLUS+1 Mobile Machine Displays	Technical Information	L1026202
DP200 Series PLUS+1 Mobile Machine Displays	Data Sheet	11025041
DP210 Series PLUS+1 Mobile Machine Displays	Data Sheet	11041319
DP211 Series PLUS+1 Mobile Machine Displays	Data Sheet	L1426132
DP250 Series PLUS+1 Mobile Machine Displays	Data Sheet	L1026137
PLUS+1 GUIDE Software User Manual	Operation Manual	10100824

Technical Information (TI)

A TI is comprehensive information for engineering and service personnel to reference.

Data Sheet (DS)

A DS is summarized information and parameters that are unique to a specific model.

API Specifications (API)

An API is specifications for programming variable settings.

[API specifications are the definitive source of information regarding pin characteristics.](#)

PLUS+1® GUIDE Software User Manual

This user operation manual (OM) details information regarding the PLUS+1 GUIDE software tool set that is used to build PLUS+1 applications. This OM covers the following broad topics:

- How to use the GUIDE graphical application development tool to create machine applications
- How to configure module input and output parameters
- How to configure module input and output parameters
- How to download GUIDE applications to target PLUS+1 hardware modules
- How to upload and download tuning parameters
- How to use the PLUS+1 service tool

Latest version of technical literature

[Up to date technical literature is available at: www.powersolutions.danfoss.com](http://www.powersolutions.danfoss.com)

User liability and safety statements

OEM responsibility

The OEM of a machine or vehicle in which Danfoss products are installed has the full responsibility for all consequences that might occur. Danfoss has no responsibility for any consequences, direct or indirect, caused by failures or malfunctions.

- Danfoss has no responsibility for any accidents caused by incorrectly mounted or maintained equipment.
- Danfoss does not assume any responsibility for Danfoss products being incorrectly applied or the system being programmed in a manner that jeopardizes safety.
- All safety critical systems shall include an emergency stop to switch off the main supply voltage for the outputs of the electronic control system. All safety critical components shall be installed in such a way that the main supply voltage can be switched off at any time. The emergency stop must be easily accessible to the operator.

Technical Information PLUS+1® Mobile Machine Displays DP2XX Series

DP2XX overview

PLUS+1® Mobile Machine Displays

PLUS+1® Mobile Machine Displays are designed to provide flexible, expandable, powerful and cost effective total machine management system displays for a wide variety of vehicle applications.

Product naming convention

DP2XX model code

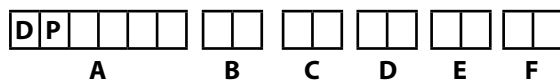

[This is not a variant configurator.](#)

A—Model name

Code	Description
DP200	Grayscale graphical display
DP210	Grayscale graphical display with USB
DP211	Grayscale graphical display with USB
DP250	Color graphical display

B—Inputs/outputs (all models have two multifunction inputs)

Code	Description
00	1 CAN port
01	1 CAN port, 4 DIN/AIN
02	1 RedCAN port
03	1 RedCAN port 2 DIN/AIN
04	2 CAN ports
05	User configurable: 2 CAN, 2 DIN/AIN or 1 CAN port, 4 DIN/AIN
06	User configurable: 1 RedCAN port, 1 CAN port or 1 RedCAN port 2, 2 DIN/AIN

C—Real Time Clock (RTC)/Low Temperature Functionality (LTF)

Code	Description
00	No RTC and LTF
01	RTC and LTF

D—Flash memory/application key (allows download of Danfoss proprietary applications and blocks)

Code	Description
02	2MB without application key
03	2MB with application key
04	16MB without application key
05	16MB with application key

DP2XX overview***E**—Application log*

Code	Description
00	None
04	2MB
05	16MB

***F**—USB port type*

Code	Description
00	None
01	USB device in front
02	USB device in rear

Technical Information PLUS+1® Mobile Machine Displays DP2XX Series
DP2XX model variants
DP200 model variants
DP200 model variants

Model type	DP200-00-00-02-00-00	DP200-00-01-03-00-00	DP200-01-01-02-00-00	DP200-01-01-03-00-00	DP200-04-01-02-00-00	DP200-04-01-03-00-00
Model number	10107021	10107380	10106883	10107381	10107022	10107382
Screen size	96.5 mm (3.8 in)	96.5 mm (3.8 in)	96.5 mm (3.8 in)	96.5 mm (3.8 in)	96.5 mm (3.8 in)	96.5 mm (3.8 in)
Inputs/outputs	1 CAN 2 Multi*	1 CAN 2 Multi*	1 CAN 4 DIN/AIN 2 Multi*	1 CAN 4 DIN/AIN 2 Multi*	2 CAN 2 Multi*	2 CAN 2 Multi*
Real Time Clock (RTC)	No	Yes	Yes	Yes	Yes	Yes
Low Temp Functionality (LTF)	-20° C (-4° F)	-40° C (-40° F)	-40° C (-40° F)	-40° C (-40° F)	-40° C (-40° F)	-40° C (-40° F)
Flash	2MB	2MB	2MB	2MB	2MB	2MB
Application key	No	Yes	No	Yes	No	Yes
Application log	No	No	No	No	No	No
USB	No	No	No	No	No	No
Ingress Protection (IP) rating	IP 67	IP 67	IP 67	IP 67	IP 67	IP 67
Mounting bracket	Yes	Yes	Yes	Yes	Yes	Yes
User manual	No	Yes (CD)	No	No	No	No
Buzzer output	Yes	Yes	Yes	Yes	Yes	Yes
Engine Information Control (EIC) software	No	Yes	No	Yes	No	Yes
RedCAN relays	No	No	No	No	No	No
Installation manual	Yes	Yes	Yes	Yes	Yes	Yes

* Multifunction inputs include the following software configurable inputs: DIN/AIN/FreqIN, Rheo, 4-20mA IN

DP210 model variants—discontinued article

[DP210 model variants—discontinued article \(replaced by DP211, see DP211 model variants on page 9\).](#)

DP210 model variants

Model type	DP210-04-01-02-04-01	DP210-04-01-03-04-01
Model number	10106884	10107383
Screen size	96.5 mm (3.8 in)	96.5 mm (3.8 in)
Inputs/outputs	2 CAN 2 Multi*	2 CAN 2 Multi*

Technical Information PLUS+1® Mobile Machine Displays DP2XX Series
DP2XX model variants
DP210 model variants (continued)

Real Time Clock (RTC)	Yes	Yes
Low Temp Functionality (LTF)	-40° C (-40° F)	-40° C (-40° F)
Flash	2MB	2MB
Application key	No	Yes
Application log	2MB	2MB
USB	USB device in front	USB device in front
Ingress Protection (IP) rating[†]	IP 54	IP 54
Mounting bracket	Yes	Yes
User manual	No	No
Buzzer output	Yes	Yes
Engine Information Control (EIC) software	No	Yes
RedCAN relays	No	No
Installation manual	Yes	Yes

* Multifunction inputs include the following software configurable inputs: DIN/AIN/FreqIN, Rheo, 4-20mA IN

† The USB cover must be in place for full IP 54 protection. DP210 models are recommended for in-cab use only.

DP211 model variants
DP211 model variants

Model type	DP211-04-01-02-04-01	DP211-04-01-03-04-01
Model number	11134226	11134227
Screen size	96.5 mm (3.8 in)	96.5 mm (3.8 in)
Inputs/outputs	2 CAN 2 Multi*	2 CAN 2 Multi*
Real Time Clock (RTC)	Yes	Yes
Low Temp Functionality (LTF)	-40° C (-40° F)	-40° C (-40° F)
Flash	2MB	2MB
Application key	Yes	Yes
Application log	2MB	2MB
USB	USB device in front	USB device in front
Ingress Protection (IP) rating[†]	IP 54	IP 54
Mounting bracket	Yes	Yes
User manual	No	No
Buzzer output	Yes	Yes
Engine Information Control (EIC) software	No	Yes

Technical Information PLUS+1® Mobile Machine Displays DP2XX Series
DP2XX model variants
DP211 model variants (continued)

RedCAN relays	No	No
Installation manual	Yes	Yes

* Multifunction inputs include the following software configurable inputs: DIN/AIN/FreqIN, Rheo, 4-20mA IN

† The USB cover must be in place for full IP 54 protection. DP211 models are recommended for in-cab use only.

DP250 model variants
DP250 model variants

Model type	DP250-00-00-04-00-00	DP250-00-01-05-00-00	DP250-01-01-04-05-00	DP250-01-01-05-05-00	DP250-05-01-04-05-00
Model number	11080686	11075899	11075900	11077442	11060814
Screen size	88.9 mm (3.5 in)	88.9 mm (3.5 in)	88.9 mm (3.5 in)	88.9 mm (3.5 in)	88.9 mm (3.5 in)
Inputs/outputs	1 CAN port 2 Multi*	1 CAN 2 Multi*	1 CAN 4 DIN/AIN 2 Multi*	1 CAN 4 DIN/AIN 2 Multi*	2 CAN 2 DIN/AIN 2 Multi* or 1 CAN, 4 DIN/AIN 2 Multi*
Real Time Clock (RTC)	No	Yes	Yes	Yes	Yes
Low Temp Functionality (LTC)	-20° C (-4° F)	-30° C (-22° F)	-30° C (-22° F)	-30° C (-22° F)	-30° C (-22° F)
Flash	16MB	16MB	16MB	16MB	16MB
Application key	No	Yes	No	Yes	No
Application log	No	No	16MB	16MB	16MB
USB	No	No	No	No	No
Ingress Protection (IP) rating	IP 67	IP 67	IP 67	IP 67	IP 67
Mounting bracket	Yes	Yes	Yes	Yes	Yes
User manual	No	Yes	No	Yes	No
Buzzer output	Yes	Yes	Yes	Yes	Yes
Engine Information Control (EIC) software	No	Yes	No	Yes	No
RedCAN relays	No	No	No	No	No

* Multifunction inputs include the following software configurable inputs: DIN/AIN/FreqIN, Rheo, 4-20mA IN

DP250 model variants

Model	DP250-05-01-05-05-00	DP250-06-01-04-05-01	DP250-06-01-05-05-01	DP250-01-01-04-05-02	DP250-01-01-05-05-02
Part number	11077443	11060816	11077444	11091448	11094414
Screen size	88.9 mm (3.5 in)	88.9 mm (3.5 in)	88.9 mm (3.5 in)	88.9 mm (3.5 in)	88.9 mm (3.5 in)

Technical Information PLUS+1® Mobile Machine Displays DP2XX Series
DP2XX model variants
DP250 model variants (continued)

Inputs/outputs	2 CAN 2 DIN/AIN, 2 Multi* or 1 CAN, 4 DIN/AIN 2 Multi*	1 RedCAN, 1 CAN 2 Multi* or 1 RedCAN, 2 DIN/AIN, 2 Multi*	1 RedCAN, 1 CAN, 2 Multi* or 1 RedCAN, 2 DIN/AIN, 2 Multi*	1 CAN port 2 Multi* 4 DIN/AIN	1 CAN port 2 Multi* 4 DIN/AIN
Real Time Clock (RTC)	Yes	Yes	Yes	Yes	Yes
Low Temp Functionality (LTF)	-30° C (-22° F)	-30° C (-22° F)	-30° C (-22° F)	-30° C (-22° F)	-30° C (-22° F)
Flash	16MB	16MB	16MB	16MB	16MB
Application key	Yes	No	Yes	No	Yes
Application log	16MB	16MB	16MB	16MB	16MB
USB	No	USB device in front	USB device in front	USB device in rear	USB device in rear
Ingress Protection (IP) rating	IP 67	IP 54	IP 54	IP 67	IP 67
Mounting bracket	Yes	Yes	Yes	Yes	Yes
User manual	Yes	No	Yes	No	No
Buzzer output	Yes	Yes	Yes	Yes	Yes
Engine Information Control (EIC) software	Yes	No	Yes	No	Yes
RedCAN relays	No	Yes	Yes	No	No

* Multifunction inputs include the following software configurable inputs: DIN/AIN/FreqIN, Rheo, 4-20mA IN

Related products
Connector bag assemblies

10102025	Deutsch® Mating Connector Bag Assembly, solid (20–24 AWG)
10100944	Deutsch Mating Connector Bag Assembly, stamped (16–20 AWG)
10103497	Binder® Connector and Cable Kit (Series 702)

Connection tools

10100744	Deutsch stamped contacts terminal crimp tool, size 20
10100745	Deutsch solid contacts terminal crimp tool

Mounting kits

10107354	Mounting hardware kit for :	DP200 DP250 without USB DP250 with USB in rear
-----------------	-----------------------------	--

DP2XX model variants*Mounting kits (continued)*

10107264	Mounting hardware kit for:	DP210 DP211 DP250 with USB in front
11079236	Optional panel mounting kit for:	All models

Software

10101000	PLUS+1® GUIDE Application Software (Including Service Tool and Screen Editor)
Online	J1939 CAN EIC Engine Monitor Software*

* Requires a model with Application Key. See [Product naming convention](#) on page 6 for model codes.

Technical Information PLUS+1® Mobile Machine Displays DP2XX Series

DP2XX connectors

DP200 connectors

Deutsch DTM06-12 connector

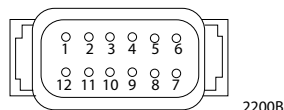

2200B

Pin assignments

Model type	DP200-00-00-02-00-00	DP200-00-01-03-00-00	DP200-01-01-02-00-00	DP200-01-01-03-00-00	DP200-04-01-02-00-00	DP200-04-01-03-00-00
Model number	10107021	10107380	10106883	10107381	10107022	10107382
Pin 1	Power Ground (-)	Power Ground (-)	Power Ground (-)	Power Ground (-)	Power Ground (-)	Power Ground (-)
Pin 2	Power Supply (+)	Power Supply (+)	Power Supply (+)	Power Supply (+)	Power Supply (+)	Power Supply (+)
Pin 3	CAN 0 High	CAN 0 High	CAN 0 High	CAN 0 High	CAN 0 High	CAN 0 High
Pin 4	CAN 0 Low	CAN 0 Low	CAN 0 Low	CAN 0 Low	CAN 0 Low	CAN 0 Low
Pin 5	AIN/ CAN Shield	AIN/ CAN Shield	AIN/ CAN Shield	AIN/ CAN Shield	AIN/ CAN Shield	AIN/ CAN Shield
Pin 6	not used	not used	DIN/AIN	DIN/AIN	not used	not used
Pin 7	not used	not used	DIN/AIN	DIN/AIN	not used	not used
Pin 8	not used	not used	DIN/AIN	DIN/AIN	CAN 1 High	CAN 1 High
Pin 9	not used	not used	DIN/AIN	DIN/AIN	CAN 1 Low	CAN 1 Low
Pin 10	Multi input*	Multi input*	Multi input*	Multi input*	Multi input*	Multi input*
Pin 11	Multi input*	Multi input*	Multi input*	Multi input*	Multi input*	Multi input*
Pin 12	Buzzer out	Buzzer out	Buzzer out	Buzzer out	Buzzer out	Buzzer out

* Multifunction inputs include the following software configurable inputs: DIN/AIN/FreqIN, Rheo, 4-20mA IN

Above pinouts are for device pins.

Use care when wiring mating connector.

DP210 and DP211 connectors

Deutsch DTM06-12 connector

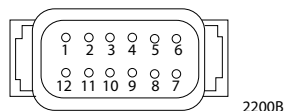

2200B

Pin Assignments

Model type	DP210-04-01-02-04-01	DP210-04-01-03-04-01	DP211-04-01-02-04-01	DP211-04-01-03-04-01
Model number	10106884	10107383	11134226	11134227
Pin 1	Power Ground (-)	Power Ground (-)	Power Ground (-)	Power Ground (-)
Pin 2	Power Supply (+)	Power Supply (+)	Power Supply (+)	Power Supply (+)
Pin 3	CAN 0 High	CAN 0 High	CAN 0 High	CAN 0 High

DP2XX connectors
Pin Assignments (continued)

Pin 4	CAN 0 Low	CAN 0 Low	CAN 0 Low	CAN 0 Low
Pin 5	AIN/CAN Shield	AIN/CAN Shield	AIN/CAN Shield	AIN/CAN Shield
Pin 6	Not used	Not used	Not used	Not used
Pin 7	Not used	Not used	Not used	Not used
Pin 8	CAN 1 High	CAN 1 High	CAN 1 High	CAN 1 High
Pin 9	CAN 1 Low	CAN 1 Low	CAN 1 Low	CAN 1 Low
Pin 10	Multi Input*	Multi Input*	Multi Input*	Multi Input*
Pin 11	Multi Input*	Multi Input*	Multi Input*	Multi Input*
Pin 12	Buzzer Out	Buzzer Out	Buzzer Out	Buzzer Out

* Multifunction inputs include the following software configurable inputs: DIN/AIN/FreqIN, Rheo, 4-20mAIN

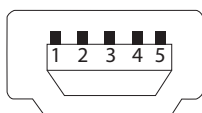
USB mini-b connector

P200 129

Pin assignments

Pin 1	Vbus
Pin 2	D -
Pin 3	D +
Pin 4	NC
Pin 5	GND

USB functionality is intended only for use with the PLUS+1® GUIDE Service Tool application. USB use is supported in PLUS+1 GUIDE Service Tool versions 4.0 and later.

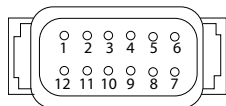
DP250 connectors
Deutsch DTM06-12 connector

2200B

Pin assignments

Model type	DP250-00-00-04-00-00	DP250-00-01-05-00-00	DP250-01-01-04-05-00	DP250-01-01-05-05-00	DP250-05-01-04-05-00
Model number	11080686	11075899	11075900	110770442	11060814
Pin 1	Power Ground (-)	Power Ground (-)	Power Ground (-)	Power Ground (-)	Power Ground (-)
Pin 2	Power Supply (+)	Power Supply (+)	Power Supply (+)	Power Supply (+)	Power Supply (+)
Pin 3	CAN 0 High	CAN 0 High	CAN 0 High	CAN 0 High	CAN 0 High
Pin 4	CAN 0 Low	CAN 0 Low	CAN 0 Low	CAN 0 Low	CAN 0 Low

Technical Information PLUS+1® Mobile Machine Displays DP2XX Series

DP2XX connectors

Pin assignments (continued)

Pin 5	AIN/CAN Shield	AIN/CAN Shield	AIN/CAN Shield	AIN/CAN Shield	AIN/CAN Shield
Pin 6	Not used	Not used	DIN/AIN	DIN/AIN	DIG/AIN
Pin 7	Not used	Not used	DIN/AIN	DIN/AIN	DIG/AIN
Pin 8	Not used	Not used	DIN/AIN	DIN/AIN	DIN/AIN/5V REFOUT CAN High
Pin 9	Not used	Not used	DIN/AIN	DIN/AIN	DIN/AIN/ CAN Low
Pin 10	Multi Input*	Multi Input*	Multi Input*	Multi Input*	Multi Input*
Pin 11	Multi Input*	Multi Input*	Multi Input*	Multi Input*	Multi Input*
Pin 12	Buzzer Out	Buzzer Out	Buzzer Out	Buzzer Out	Buzzer Out

* Multifunction inputs include the following software configurable inputs: DIN/AIN/FreqIN, Rheo, 4-20mA IN

Model type	DP250-05-01-05-05-00	DP250-06-01-04-05-01	DP250-06-01-05-05-01	DP250-01-01-04-05-02	DP250-01-01-05-05-02
Model number	11077443	11060816	11077444	11091448	11094414
Pin 1	Power Ground (-)	Power Ground (-)	Power Ground (-)	Power Ground (-)	Power Ground (-)
Pin 2	Power Supply (+)	Power Supply (+)	Power Supply (+)	Power Supply (+)	Power Supply (+)
Pin 3	CAN 0 High	CAN 0 High	CAN 0 High	CAN 0 High	CAN 0 High
Pin 4	CAN 0 Low	CAN 0 Low	CAN 0 Low	CAN 0 Low	CAN 0 Low
Pin 5	A/CAN Shield	AIN/CAN Shield	AIN/CAN Shield	AIN/CAN Shield	AIN/CAN Shield
Pin 6	DIN/AIN	RedCAN 0 High	RedCAN 0 High	DIN/AIN	DIN/AIN
Pin 7	DIN/AIN	RedCAN 0 Low	RedCAN 0 Low	DIN/AIN	DIN/AIN
Pin 8	DIN/AIN/ 5V REFOUT CAN 1 High	DIN/AIN/ 5V REFOUT CAN 1 High	DIN/AIN/ 5V REFOUT CAN 1 High	DIN/AIN	DIN/AIN
Pin 9	DIN/AIN/ CAN 1 Low	DIN/AIN/ CAN 1 Low	DIN/AIN/ CAN 1 Low	DIN/AIN	DIN/AIN
Pin 10	Multi Input*	Multi Input*	Multi Input*	Multi Input*	Multi Input*
Pin 11	Multi Input*	Multi Input*	Multi Input*	Multi Input*	Multi Input*
Pin 12	Buzzer out	Buzzer out	Buzzer out	Buzzer out	Buzzer out

* Multifunction inputs include the following software configurable inputs: DIN/AIN/FreqIN, Rheo, 4-20mA IN

USB mini-b connector

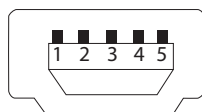

P200 129

Pin assignments

Pin 1	Vbus
Pin 2	D -

DP2XX connectors
Pin assignments (continued)

Pin 3	D +
Pin 4	NC
Pin 5	GND

USB functionality is intended only for use with the PLUS+1® GUIDE Service Tool application. USB use is supported in PLUS+1 GUIDE Service Tool versions 4.0 and later.

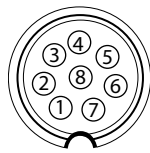
Binder Series 702 USB connector

P200 130

Pin assignments

Pin 1	USB Device Vbus output
Pin 2	USB Device D -
Pin 3	USB Device D +
Pin 4	USB Device GND
Pin 5	Not Used
Pin 6	Not Used
Pin 7	Not Used
Pin 8	Not Used

DP2XX input/output types and specifications
Input types

- Digital or Analog (DIN/AIN)
- Multifunction: Digital or Analog or Frequency or Rheostat or 4-20 mA (Din/AIN/FreqIN, Rheo, 4–20 mA IN)
- Analog or Temperature or Rheostat (AIN/Temp/Rheo)
- Fixed Range Analog or CAN shield (AIN/CAN shield)

Each PLUS+1® Module input pin supports one of the above functional types. For pins with multiple functions, input configurations are user programmable using PLUS+1 GUIDE templates.

The DP2XX series graphical displays do not have a Real Time Operating System (RTOS). Do not use the display as the master control for any type of safety critical control, or closed loop control system. Frequency inputs are managed by the operating system. Avoid using these inputs for any type of Safety Critical closed loop control as the accuracy may be affected by processor load. DP2XX displays should only be used for non-safety critical related functions.

Low level digital/analog inputs
Low level digital input

Description	Unit	Minimum	Maximum	Typical	Comment
Voltage range	V	0	5.5	—	—
Input resistance	kΩ	—	—	233	No pullup/down
				14	With pull up to 5 V
				14	Pull down to ground
				7.3	With pull up and pull down to 5 V
Programmable low threshold voltage	V	0	5.5	—	—
Programmable high threshold voltage	V	0	5.5	—	—
Rise time	μs	—	—	10	—
Fall time	μs	—	—	10	—

Low level analog input

Description	Unit	Minimum	Maximum	Typical	Comment
Voltage range	V	0	5.5	—	—
Input resistance	kΩ	—	—	233	No pullup/down
				14	With pull up to 5 V
				14	Pull down to ground
				7.3	With pull up and pull down to 5 V
Analog voltage error	mV	—	—	± 20	U _{in} = 0 V
				± 107	U _{in} = 5 V
Bandwidth	kHz	—	—	12	—

DP2XX input/output types and specifications
High digital/analog inputs
High level digital input

Description	Unit	Minimum	Maximum	Typical	Comment
Voltage range	V	0	70	—	—
Input resistance	kΩ	—	—	105	No pullup/down
				13	With pull up to 5 V
				13	Pull down to ground
				7	With pull up and pull down to 5 V
Programmable low threshold voltage	V	0	70	—	—
Programmable high threshold voltage	V	0	70	—	—
Rise time	μs	—	—	10	—
Fall time	μs	—	—	10	—

High level analog input

Description	Unit	Minimum	Maximum	Typical	Comment
Voltage range	V	0	70	—	—
Input resistance	kΩ	—	—	105	No pullup/down
				13	With pull up to 5 V
				13	Pull down to ground
				7	With pull up and pull down to 5 V
Analog voltage error ± (300 mV+U _{in} x 3.4 %)	mV	—	—	± 100	U _{in} = 0 V
				± 2700	U _{in} = 70 V
Bandwidth	kHz	—	—	13	—

Low level multifunction inputs
Low level digital input

Description	Unit	Minimum	Maximum	Typical	Comment
Voltage range	V	0	5.5	—	—
Input resistance	kΩ	—	—	233	No pullup/down
				14	With pull up to 5 V
				14	Pull down to ground
				7.3	With pull up and pull down to 5 V
Programmable low threshold voltage	V	0	5.5	—	—
Programmable high threshold voltage	V	0	5.5	—	—
Rise time	μs	—	—	10	—

DP2XX input/output types and specifications
Low level analog input

Description	Unit	Minimum	Maximum	Typical	Comment
Voltage range	V	0	5.5	—	—
Input resistance	kΩ	—	—	233	No pullup/down
				14	With pull up to 5 V
				14	Pull down to ground
				7.3	With pull up and pull down to 5 V
Analog voltage error	mV	—	—	± 7	U _{in} = 0 V
				± 107	U _{in} = 5 V
Bandwidth	kHz	—	—	12	—

High level multifunction inputs
High level digital input

Description	Unit	Minimum	Maximum	Typical	Comment
Voltage range	V	0	70	—	—
Input resistance	kΩ	—	—	105	No pullup/down
				13	With pull up to 5 V
				13	Pull down to ground
				7	With pull up and pull down to 5 V
Programmable low threshold voltage	V	0	70	—	—
Programmable high threshold voltage	V	0	70	—	—
Rise time	μs	—	—	10	—
Fall time	μs	—	—	10	—

High level analog input

Description	Unit	Minimum	Maximum	Typical	Comment
Voltage range	V	0	70	—	—
Input resistance	kΩ	—	—	105	No pullup/down
				13	With pull up to 5 V
				13	Pull down to ground
				7	With pull up and pull down to 5 V
Analog voltage error ± (300 mV+U _{in} x 3.4 %)	mV	—	—	± 100	U _{in} = 0 V
				± 2700	U _{in} = 70 V
Bandwidth	kHz	—	—	13	—

DP2XX input/output types and specifications
Multifunction input ranges
Resistance input

Description	Unit	Minimum	Maximum	Typical	Comment
Resistance range	k Ω	0	10	—	—
Input resistance	k Ω	—	1.33	—	Pull up to 5 V
Resistance error	Ω	—	± 1	—	R = 0 k Ω
			± 201		R = 10 k Ω

*Current input**

Description	Unit	Minimum	Maximum	Typical	Comment
Current range	—	0	25	—	DP200 and DP210: Shut off at 28 mA
					DP211 and DP250: Shut off at 50 mA
Input resistance	Ω	—	—	100	2.0 V at 20 mA input current
Current error ($\pm 3.5\%$)	mA	—	± 0.1	—	lin = 0 mA
			± 0.8		lin = 20 mA

*There can be problems with overload when using these inputs together with some sensors.

When some sensors are powered up, a significant amount of current is used to charge capacitors in the sensor. This causes the internal protection circuitry to disconnect and give status overload. The overload status cannot be reset from the display software. This is due to the fact that the protection circuit is done in hardware and once disconnected it is continually in overload. To recover the current input needs to be disconnected or grounded. The protection circuit is for preventing terminal damage to the resistor which is used to measure the current.

The DP2XX buzzer output which is an NPN output can be used to ground the current input and create a reset of the overload situation. This output needs to be externally wired to the current sensor input. The buzzer output cannot be used for anything else when used for reset of overload on current sensor input.

Frequency input

Description	Unit	Minimum	Maximum	Typical	Comment
Frequency range	kHz	0	10	—	—

Positive duty input

Description	Unit	Minimum	Maximum	Typical	Comment
Positive duty cycle range	%	0.01	100	—	—

Count input

Description	Unit	Minimum	Maximum	Typical	Comment
Count range	Count s	0	65536	—	—

Quad count input

Description	Unit	Minimum	Maximum	Typical	Comment
Count range	Count s	0	$\pm 3276/8$	—	—

DP2XX input/output types and specifications
CAN Shield and analog (5 V only) inputs ranges
CAN Shield

Description	Unit	Minimum	Maximum	Typical	Comment
Input impedance	—	—	—	1 μ F+1 Ω	—

Analog input (5 V only)

Description	Unit	Minimum	Maximum	Typical	Comment
Voltage range	V	0	5.5		—
Input resistance	k Ω	—	—	233	—
Analog voltage error \pm (20 mV+Uin x 1.6 %)	mV	—	\pm 7	—	Uin = 0 V
			\pm 107		Uin = 5 V
Bandwidth	kHz	—	—	2.8	—

Alarm output
Alarm output

Description	Unit	Minimum	Maximum	Comment
Current	A	0	1	—
Short circuit current	A	—	2	—
Short circuit current peak	A	—	8	—
Saturation voltage	V	—	1	At 1 A
Current measurement	A	0	2	—
Current measurement error	mA	—	\pm 60	0 A
			\pm 75	1 A

CAN/RedCAN communication
CAN DP200, DP210/DP211

Description	Unit	Minimum	Maximum	Typical	Comment
Available Baud rates	kbps	0.01	100	111.111	With 120 Ω termination
				125	
				250	
				500	
				1000	
Maximum input voltage range	V	0	36	—	—

DP2XX input/output types and specifications
CAN/RedCAN DP250

Description	Unit	Minimum	Maximum	Typical	Comment
Available Baud rates	kbps	0.01	100	111.111	With 120 Ω termination
				125	
				250	
				500	
				1000	
Maximum input voltage range	V	0	70	—	—

DP2XX ratings
Electronic components environmental testing criteria
Climate environment

Description	Applicable standard	Comment
Storage temperature	IEC 60068-2-1, test Ab, IEC 60068-2-2 test Bb	
Operating temperature	IEC 60068-2-1, test Ab, IEC 60068-2-2 test Bd	
Thermal cycle	IEC 60068-2-2, test Na, IEC 60068-2-38 (partial)	
Humidity	IEC 60068-2-78, IEC 60068-2-30 test Db	Damp heat steady state and cyclic.
Degree of protection	IEC 60529	

Chemical environment

Description	Applicable standard	Comment
Salt mist	IEC 60068-2-58 test Kb	
Chemical resistance	ISO 16750-5	

Mechanical environment

Description	Applicable standard	Comment
Vibration	IEC 60068-2-6 test Fc, IEC6008-2-64 test Fh	
Bump	IEC 60068-2-29 test Eb	
Shock	IEC 60068-2-27 test Ea	
Free fall	IEC 60068-2-32 test Ed	

Electrical/electromagnetic

Description	Applicable standard	Comment
EMC emission	ISO 13766, SAE J1113-13	Electromagnetic compatibility for earth moving machinery.
EMC immunity	ISO 13766	Electromagnetic compatibility for earth moving machinery.
Electrostatic discharge	EN 60-1 000-4-2	
Auto electrical transients	ISO 7637-2, ISO 7637-3	
Short circuit protection	Danfoss test	Inputs and outputs survive continuous short circuit. Normal function resumes when short is removed.
Reversed polarity protection	Danfoss test	Survives reverse polarity at supply voltage for at least five minutes.

Supply voltage/maximum current ratings

DP2XX graphical displays are designed to operate with a nominal 9 to 63 Vdc power supply with reverse polarity protection.

Technical Information PLUS+1® Mobile Machine Displays DP2XX Series
DP2XX ratings
Supply voltage

Description	Unit	DP200/DP210/ DP211	DP250	Comment
DC supply voltage	Volt	9 to 36	9 to 63	With reverse polarity protection
DC supply current (circuit board only)	mA	215	380	UBat = 9V
		130	219	UBat = 14V
		70	121	UBat = 28V
		40	75	UBat = 63V
Heater	W	3.6 when on		DP250 heater current consumption is temperature dependent
		5 at 0° C (32° F)		
		10 at - 40° C (-40 F)		
Power supply interruption (without rebooting)	ms	30	34	According to ISO 7637-2
		35	36	
		55	46	
		140	100	
Load dump protection, 28V systems, % pulses, cycle time 100 s, criteria C	V	200		According to ISO 7637-2
	Ω	3		
	ms	200		
	ms	10		
Auto heater shut off	° C (° F)	—		Auto over temp protection- heater shuts off when not needed
5 V reference output	V	Minimum 4.75, Maximum 5.25		—

5 V reference output

Description	Unit	Minimum	Maximum
Output voltage	V	4.75	5.25
Output current	A	0.5	—
Output short circuit	A	—	1
Short circuit protection	V	0	70

USB input/output parameters

Description	Unit	Minimum	Typical	Maximum	Comment
2.0 full speed	Mbit/s	—	12	—	—
Vbus input voltage	Volt	75	—	5.25	—
Vbus input resistance	kΩ	3.6	47	—	—
Short circuit protection (oo damage)	V	0	—	70	—
Vbus output voltage	V	75	—	5.25	—
Vbus output current	A	5	—	—	—
Vbus short current	A	—	—	1	—

DP2XX ratings**Ingress Protection (IP) rating**

DP2XX displays (except USB in front model) carry a full Ingress Protection rating of IP 67 only if the rear USB mating connector or seal plug is in place.

DP2XX displays with a front mini USB option carry a full Ingress Protection rating of IP 54 only if the USB mating connector or seal plug cover is in place.

DP2XX installation and start-up

Dimensions

mm [in]

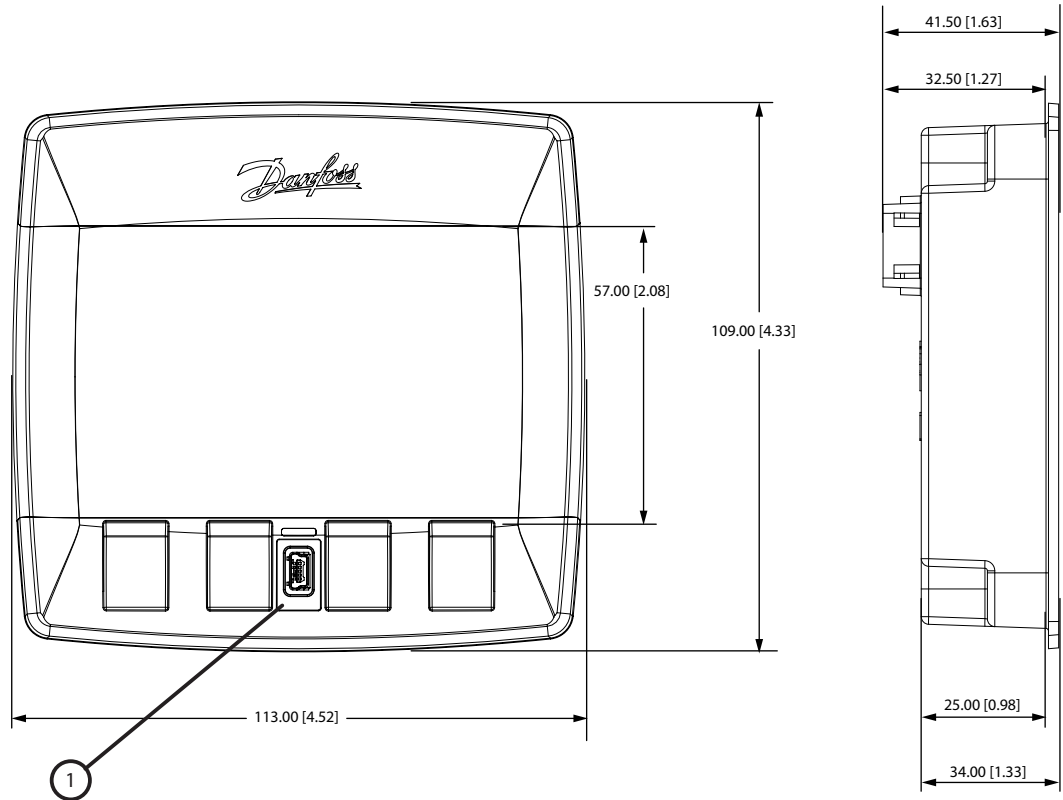

P200132

Callout

Callout	Description
1	Universal Serial Bus (USB)

Mounting

! Caution

Oversized panel cutouts may jeopardize product IP rating.

! Caution

Excessive screw torque force can cause damage to housing. Maximum torque: 0.9 Nm.

DP2XX installation and start-up

Suggested mounting procedure—mm [in]

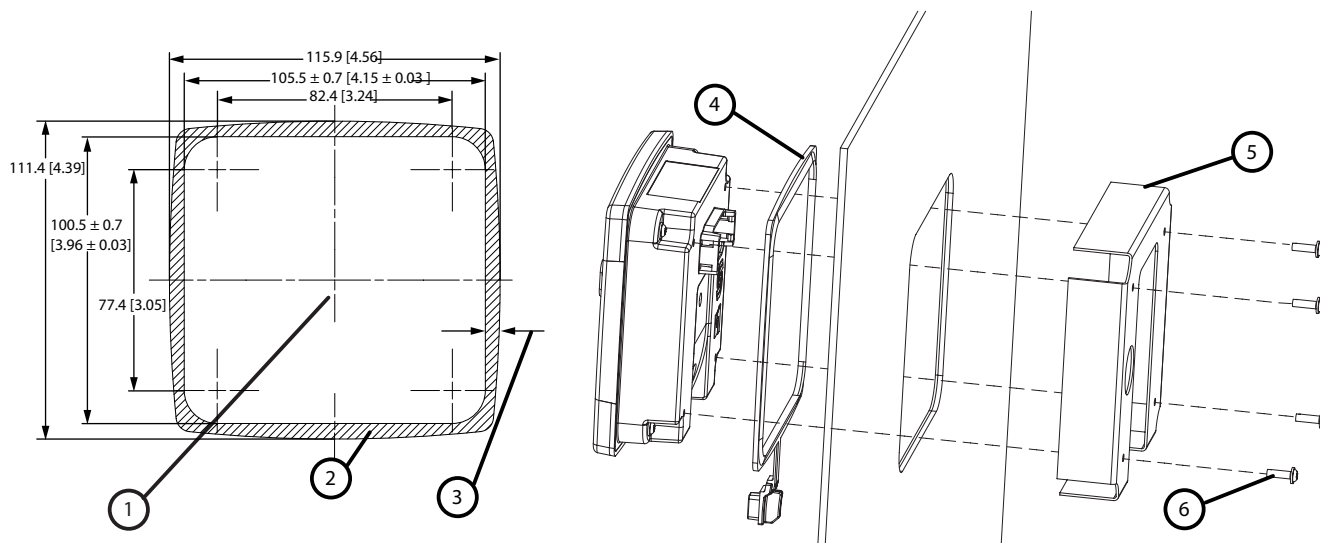

P200 135

Suggested mounting procedure callouts

Callout	Description
1	Hole for panel mounting
2	Gasket seal area
3	Panel thickness: 2 to 5 mm (0.079 to 0.197 in)
4	Panel seal
5	Panel bracket
6	Four screws

Mounting screw placement

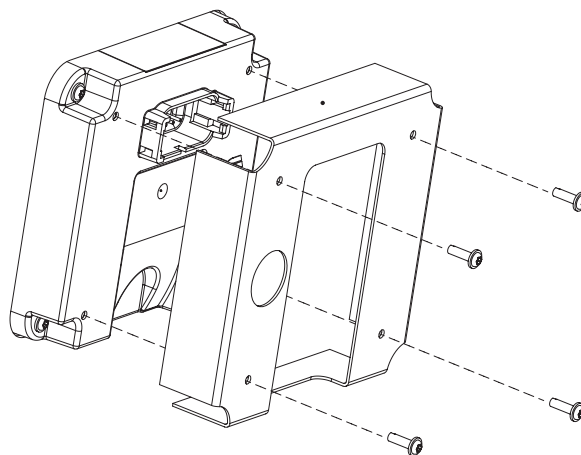

P200 134

DP2XX installation and start-up

Fastening

! Caution

- Use of non-recommended screws may cause damage to housing.
- Excessive torque force may cause damage to housing. Maximum torque: 0.9 Nm.
- Reassembly with self-tapping screws may damage existing threads in housing.

Fastening procedure—mm [in]

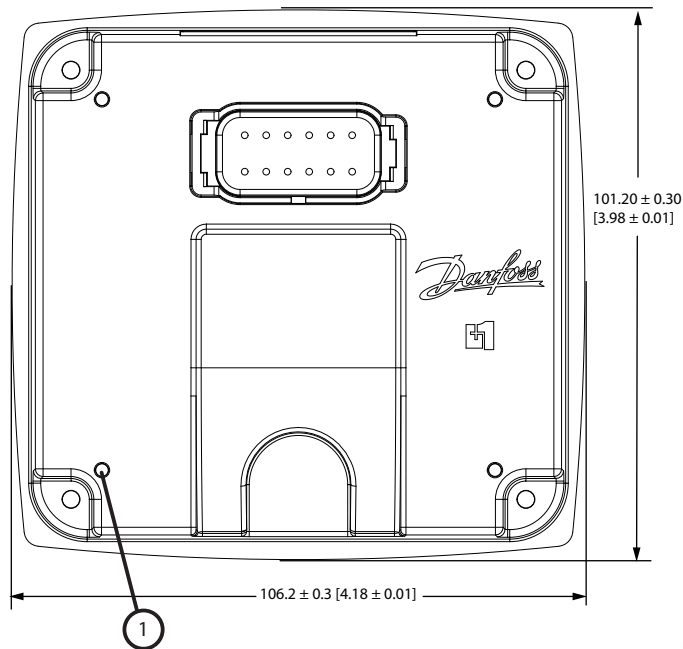

P200 131

Fastening procedure callouts

Callout	Description
1	Fastening hole depth: 11 mm (0.43 in). May be threaded M3 and used with standard screws.

DP2XX installation and start-up

Display operation guidelines

- Disconnect your machine's battery power before connecting power and signal cables to the display.
- Before doing any electrical welding on your machine, disconnect all power and signal cable cables connected to the display.
- Do not exceed the display power supply voltage ratings. Using higher voltages may damage the display and can create a fire or electrical shock hazard.
- Do not use or store the display where flammable gases or chemicals are present. Using or storing the display where flammable gases or chemicals are present may cause an explosion.
- Software configures the keypad buttons on the display. Do not use these buttons to implement critical safety features. Use separate mechanical switches to implement critical safety features such as emergency stops.
- Design systems that use the display so that a communication error or failure between the display and other units cannot cause a malfunction that might injure people or damage material.
- The protective glass over the display screen will break if hit with a hard or heavy object. Install the display to reduce the possibility of it being hit by hard or heavy objects.
- Storing or operating a display in an environment that exceeds the display specified temperature or humidity rating may damage the display.
- Always clean the display with a soft, damp cloth. Use a mild dishwashing detergent as needed. To avoid scratching and discoloring the display, do not use abrasive pads, scouring powders, or solvents such as alcohol, benzene, or paint thinner.
- Danfoss graphical displays are not user serviceable. Return the display to the factory in case of failure.

Recommended machine wiring guidelines

1. All wires must be protected from mechanical abuse. Wires should be run in flexible metal or plastic conduits.
2. Use 85° C [185° F] wire with abrasion resistant insulation. 105° C [221° F] wire should be considered near hot surfaces.
3. Use a wire size that is appropriate for the module connector.
4. Separate high current wires such as solenoids, lights, alternators or fuel pumps from sensor and other noise-sensitive input wires.
5. Run wires along the inside of, or close to, metal machine surfaces where possible. This simulates a shield which will minimize the effects of EMI/RFI radiation.
6. Do not run wires near sharp metal corners. Consider running wires through a grommet when rounding a corner.
7. Do not run wires near hot machine members.
8. Provide strain relief for all wires.
9. Avoid running wires near moving or vibrating components.
10. Avoid long, unsupported wire spans.
11. All analog sensors should be powered by the sensor power source from the PLUS+1® controller and ground returned to the sensor ground pin on the PLUS+1® controller.
12. Sensor lines should be twisted about one turn every 10 cm [4 in].
13. It is better to use wire harness anchors that will allow wires to float with respect to the machine rather than rigid anchors.
14. Electronic modules should be grounded to a dedicated conductor of sufficient size that is connected to the battery (-).

Electronic components welding guidelines

Remove electronic components from the machine before any arc welding. The following is recommended when welding on a machine equipped with electronic components:

DP2XX installation and start-up

- Turn the engine off.
- Disconnect the negative battery cable from the battery.
- Do not use electronic components to ground the welder.
- Clamp the ground cable for the welder to the component that will be welded as close as possible to the weld.

Limiting crosstalk

Due to the general characteristics of the grayscale DP2XX series graphical display, the display may contain faint shadow-like images. This is called crosstalk, a common occurrence in LCD displays.

Crosstalk is a result of pixel interference due to the constraints of the LCD design.

Crosstalk is very pattern-dependent. It may or may not occur, it is dependent on the actual images used and the placement of the images within the display. If multiple grayscale images are used, ensure that they are as small as possible and not placed in the same vertical position. Also, try to avoid using both black and white and grayscale images in the same vertical position.

Contrast and backlight controls can be used in some cases to help counteract crosstalk ghosting. If there are bright lines in dark area; the contrast is set too low. Adjust backlight intensity to enhance visibility.

Visibility and viewing radius

Due to the display nature of the TFT-LCD screen, the optimal viewing angle for the DP2XX series graphical display is at a maximum radius of 45° from either side of the screen.

Optimal viewing angle

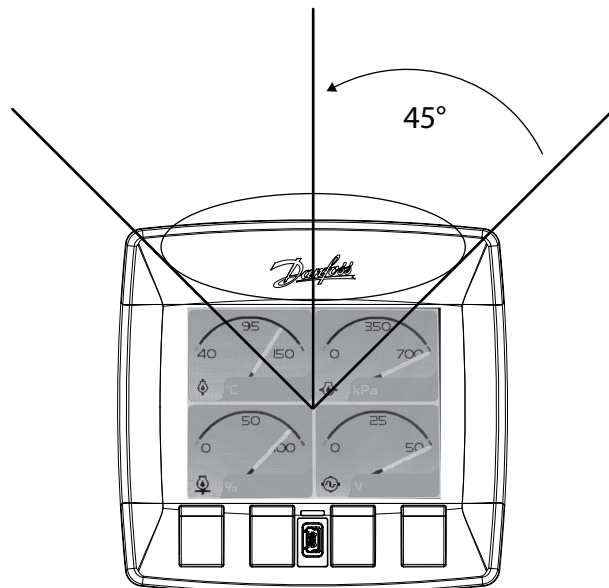

P200 133

Display faulty application recovery

The boot loader is always executed when the unit is powered. The boot loader checks if the application has the completely downloaded flag set and in that case starts to execute it after a delay of 200 ms. The delay gives an opportunity for the PLUS+1® Guide Service Tool to prevent the call to the application. This allows a non functional application to be replaced by the boot loader. This recovery function is activated by the Communication>Recover ECU menu in the PLUS+1 Guide Service Tool.

USB communication requires more time than 200 ms to be established. The units with USB have a function to force a recovery mode entry when the USB channel is used.

To force a recovery, follow this procedure:

DP2XX installation and start-up

1. Connect the USB cable to the PC and the unit.
2. Start the service tool and select the display as the communication gateway.
3. Depress the leftmost and the rightmost push button before the unit is powered.

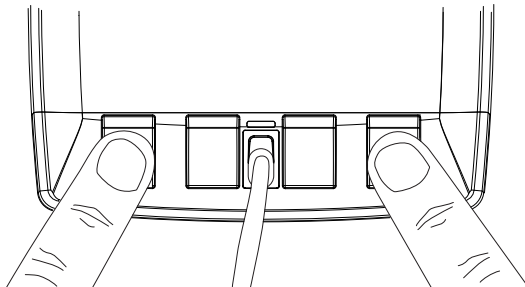

P200 136

4. Apply power to the unit with the push buttons depressed.

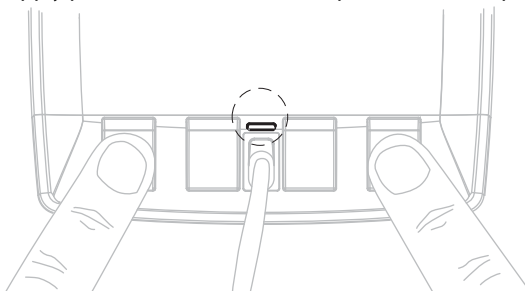

P200 137

5. Release the push buttons when the LED above the USB receptacle is lit. The unit will now stay to execute the boot loader and allow the application program to be replaced.

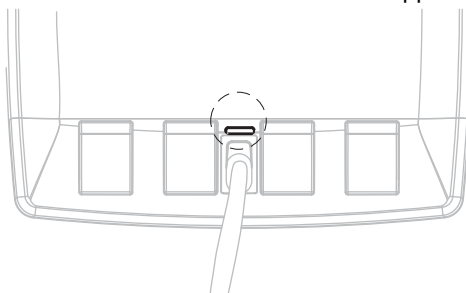

P200 138



Products we offer:

- Bent Axis Motors
- Closed Circuit Axial Piston Pumps and Motors
- Displays
- Electrohydraulic Power Steering
- Electrohydraulics
- Hydraulic Power Steering
- Integrated Systems
- Joysticks and Control Handles
- Microcontrollers and Software
- Open Circuit Axial Piston Pumps
- Orbital Motors
- PLUS+1® GUIDE
- Proportional Valves
- Sensors
- Steering
- Transit Mixer Drives

Danfoss Power Solutions is a global manufacturer and supplier of high-quality hydraulic and electronic components. We specialize in providing state-of-the-art technology and solutions that excel in the harsh operating conditions of the mobile off-highway market. Building on our extensive applications expertise, we work closely with our customers to ensure exceptional performance for a broad range of off-highway vehicles.

We help OEMs around the world speed up system development, reduce costs and bring vehicles to market faster.

Danfoss – Your Strongest Partner in Mobile Hydraulics.

Go to www.powersolutions.danfoss.com for further product information.

Wherever off-highway vehicles are at work, so is Danfoss.

We offer expert worldwide support for our customers, ensuring the best possible solutions for outstanding performance. And with an extensive network of Global Service Partners, we also provide comprehensive global service for all of our components.

Please contact the Danfoss Power Solution representative nearest you.

Comatrol

www.comatrol.com

Schwarz Müller-Inverter

www.schwarzmueller-inverter.com

Turolla

www.turollaocg.com

Valmova

www.valmova.com

Hydro-Gear

www.hydro-gear.com

Daikin-Sauer-Danfoss

www.daikin-sauer-danfoss.com

Local address:

Danfoss Power Solutions US Company

2800 East 13th Street
Ames, IA 50010, USA
Phone: +1 515 239 6000

Danfoss Power Solutions GmbH & Co. OHG

Krokamp 35
D-24539 Neumünster, Germany
Phone: +49 4321 871 0

Danfoss Power Solutions ApS

Nordborgvej 81
DK-6430 Nordborg, Denmark
Phone: +45 7488 2222

Danfoss Power Solutions (Shanghai) Co., Ltd.

Building #22, No. 1000 Jin Hai Rd
Jin Qiao, Pudong New District
Shanghai, China 201206
Phone: +86 21 3418 5200

Danfoss can accept no responsibility for possible errors in catalogues, brochures and other printed material. Danfoss reserves the right to alter its products without notice. This also applies to products already on order provided that such alterations can be made without changes being necessary in specifications already agreed.. All trademarks in this material are property of the respective companies. Danfoss and the Danfoss logotype are trademarks of Danfoss A/S. All rights reserved.