

User's Manual



IF30 Fixed Reader

Intermec Technologies Corporation

Worldwide Headquarters

6001 36th Ave.W.

Everett, WA 98203

U.S.A.

www.intermec.com

The information contained herein is provided solely for the purpose of allowing customers to operate and service Intermec-manufactured equipment and is not to be released, reproduced, or used for any other purpose without written permission of Intermec Technologies Corporation.

Information and specifications contained in this document are subject to change without prior noticed and do not represent a commitment on the part of Intermec Technologies Corporation.

© 2007 by Intermec Technologies Corporation. All rights reserved.

The word Intermec, the Intermec logo, Norand, ArciTech, Beverage Routebook, CrossBar, dcBrowser, Duratherm, EasyADC, EasyCoder, EasySet, Fingerprint, i-gistics, INCA (under license), Intellitag, Intellitag Gen2, JANUS, LabelShop, MobileLAN, Picolink, Ready-to-Work, RoutePower, Sabre, ScanPlus, ShopScan, Smart Mobile Computing, SmartSystems, TE 2000, Trakker Antares, and Vista Powered are either trademarks or registered trademarks of Intermec Technologies Corporation.

There are U.S. and foreign patents as well as U.S. and foreign patents pending.

Contents

Before You Begin	vii
Safety Information	vii
Global Services and Support	vii
Warranty Information	vii
Web Support	vii
Telephone Support	viii
Who Should Read This Manual	ix
Related Documents	ix
Patent Information	x

1 Getting Started 1

Overview of the IF30	2
Unpacking the IF30	3
What You Need	3
Learning About the IF30	4
Understanding the Front Panel Ports	4
Understanding the LEDs	6
Learning About the Intermec Ready-To-Work Indicator	7
Understanding the Rear Panel Ports	8
How the IF30 Fits in Your Network	9
Configuring the IF30 (Setting the IP Address)	9
Using a Communications Program	10
Configuring the IF30 for an Ethernet Connection	11
Using the Web Browser Interface	14
Saving Configuration Changes	15
Installing the IF30	18
Choosing a Mounting Location	18
Connecting the IF30 to Your Network	19
Setting the Date and Time	20
Using the IF30 Securely	21

2	Configuring Network Settings	23
	Configuration Settings For Your Network	24
	Configuring Ethernet Settings	24
	Enabling IPv6	27
	Configuring Network Services	28
	Configuring SNTP Client Settings	30
	Configuring Security	30
	Controlling Access to IF30 Menus	31
	Setting Up Logins	33
	Configuring the IF30 to Use a Password Server	34
	Changing the Default Login	35
	About Certificates	37
	Viewing Certificates	37
	Installing and Uninstalling Certificates	38
	Rejecting Expired Certificates	39
3	Creating and Using RFID Applications	41
	RFID Applications and the IF30	42
	Creating Applications for the IF30	42
	Configuring RFID Settings	42
	About RFID Module Settings	44
	Supported Tag Type	44
	Supported Tag Type (Gen 2)	44
	Dense Reader Mode	44
	LBT Channel	44
	LBT Scan Enable	45
	Field Separator	45
	ID Report	45
	No Tag Report	45
	Timeout Configuration Mode	45
	ID Tries	46
	Antenna Tries	46
	Read Tries	46
	Write Tries	46
	Initialization Tries	46

Lock Tries	47
Select Tries.	47
Unselect Tries	47
Initial Queue	47
Session	47
Field Strength	47
Enable Antenna Port n.	48
Configuring the Data Collection Engine.	48
Viewing the DCE Events Log.	50
Viewing DCE Statistics	51

4 Managing, Upgrading, and Troubleshooting the IF30 . . 53

Managing the IF30	54
Using Intermec SmartSystems Foundation	54
Configuring the IF30 with Intermec Settings	54
Using Wavelink Avalanche	55
Enabling Simple Network Management Protocol (SNMP)	57
Maintaining the IF30	60
Viewing Port Statistics	60
Viewing the Events Log	61
Viewing the About This IF30 RFID Reader Screen	62
Viewing the IF30 Configuration Summary	63
Restoring the IF30 to the Default Configuration	65
Upgrading Firmware	66
Troubleshooting the IF30	68
Problems While Working With RFID	68
Problems With Network Connectivity	69
Calling Intermec Product Support	70

5	Using the IF30 GPIO Interfaces	71
	About the GPIO Interfaces	72
	Accessing the GPIO Interfaces	72
	Using the Input Interfaces	73
	IF30 Powered Input	73
	Isolated Input Interface	74
	Open Collector Interface	74
	Using the Output Interfaces	75
	Switching the High Side Using IF30 Power	76
	Switching the Low Side Using IF30 Power	76
	Switching the High Side Using External Power	77
	Driving a DC Relay to Control an AC Load	78
	Using the Power Interface	78
A	Specifications	79
	IF30 Specifications	80
	RFID Specifications	81
	Port Pin Assignments	82
	Control Port	82
	Serial Port	83
	Ethernet Port	83
	Index	85

Before You Begin

This section provides you with safety information, technical support information, and sources for additional product information.

Safety Information

Your safety is extremely important. Read and follow all warnings and cautions in this document before handling and operating Intermec equipment. You can be seriously injured, and equipment and data can be damaged if you do not follow the cautions.

This section explains how to identify and understand warnings, cautions, and notes that are in this document.



A warning alerts you of an operating procedure, practice, condition, or statement that must be strictly observed to avoid death or serious injury to the persons working on the equipment.



A caution alerts you to an operating procedure, practice, condition, or statement that must be strictly observed to prevent equipment damage or destruction, or corruption or loss of data.



Note: Notes either provide extra information about a topic or contain special instructions for handling a particular condition or set of circumstances.

Global Services and Support

Warranty Information

To understand the warranty for your Intermec product, visit the Intermec web site at www.intermec.com and click **Service & Support > Warranty**.

Web Support

Visit the Intermec web site at www.intermec.com to download our current manuals (in PDF). To order printed versions of the Intermec manuals, contact your local Intermec representative or distributor.

Before You Begin

Visit the Intermec technical knowledge base (Knowledge Central) at intermec.custhelp.com to review technical information or to request technical support for your Intermec product.

Telephone Support

These services are available from Intermec.

		In the USA and Canada call 1-800-755-5505 and choose this option
Services	Description	
Order Intermec products	<ul style="list-style-type: none">Place an order.Ask about an existing order.	1 and then choose 2
Order Intermec media	Order printer labels and ribbons.	1 and then choose 1
Order spare parts	Order spare parts.	1 or 2 and then choose 4
Technical Support	Talk to technical support about your Intermec product.	2 and then choose 2
Service	<ul style="list-style-type: none">Get a return authorization number for authorized service center repair.Request an on-site repair technician.	2 and then choose 1
Service contracts	<ul style="list-style-type: none">Ask about an existing contract.Renew a contract.Inquire about repair billing or other service invoicing questions.	1 or 2 and then choose 3

Outside the U.S.A. and Canada, contact your local Intermec representative. To search for your local representative, from the Intermec web site, click **Contact**.

Who Should Read This Manual

This manual is for the person who is responsible for installing, configuring, and maintaining the IF30.

This manual provides you with information about the features of the IF30, and how to install, configure, operate, maintain, and troubleshoot it.

Before you work with the IF30, you should be familiar with your network and general networking terms, such as IP address. You should also be familiar with your RFID system.

Related Documents

This table contains a list of related Intermec documents and their part numbers.

Document Title	Part Number
<i>IF30 Fixed Reader Quick Start Guide</i>	930-188-xxx
<i>Basic Reader Interface Programmer's Reference Manual</i>	937-000-xxx
<i>IF30 Compliance Insert</i>	933-056-xxx
<i>IM5 Compliance Insert</i>	075231-xxx

The Intermec web site at www.intermec.com contains our documents (as PDF files) that you can download for free.

To download documents

- 1** Visit the Intermec web site at www.intermec.com.
- 2** Click **Service & Support > Manuals**.
- 3** In the **Select a Product** field, choose the product whose documentation you want to download.

To order printed versions of the Intermec manuals, contact your local Intermec representative or distributor.

Patent Information

Product is covered by one or more of the following patents:

4,999,636; 5,030,807; 5,055,659; 5,070,536; 5,280,159;
5,295,154; 5,349,678; 5,394,436; 5,425,051; 5,428,636;
5,483,676; 5,504,485; 5,504,746; 5,521,601; 5,546,397;
5,550,547; 5,574,979; 5,592,512; 5,673,037; 5,680,633;
5,682,299; 5,696,903; 5,740,366; 5,763,867; 5,777,561;
5,790,536; 5,825,045; 5,828,318; 5,828,693; 5,844,893;
5,850,181; 5,850,187; 5,862,171; 5,940,771; 5,942,987;
5,960,344; 5,995,019; 6,078,251; 6,121,878; 6,122,329;
6,172,596; 6,195,053; 6,249,227; 6,280,544; 6,286,762;
6,286,763; 6,288,629; 6,360,208; 6,384,712; 6,404,325;
6,429,775; 6,486,769; 6,501,807; 6,525,648; 6,639,509;
6,645,327; 6,677,852; 6,768,414; 6,784,789; 6,816,063.

There may be other U.S. and foreign patents pending.



1 Getting Started

This chapter introduces the IF30 Fixed Reader. It explains the ports and LEDs, and explains how the reader fits into your network. It contains these topics:

- Overview of the IF30
- Unpacking the IF30
- Learning About the IF30
- How the IF30 Fits in Your Network
- Configuring the IF30 (Setting the IP Address)
- Saving Configuration Changes
- Installing the IF30
- Setting the Date and Time
- Using the IF30 Securely

Overview of the IF30

The IF30 Fixed Reader is an RFID reader that provides connectivity between tag data and an enterprise system.



The IF30 Fixed Reader



95011012600000094

The IF30 Fixed Reader uses an EPCglobal Gen 2-certified IM5 Module (86x MHz RFID frequency band).



950110126000000100

The IF30 Fixed Reader uses an EPCglobal Gen 2-certified IM5 Module (915 MHz RFID frequency band).

Unpacking the IF30

When you unpack the IF30, save the box and shipping material in case you need to ship or store the IF30. The reader comes with a documentation packet that includes a quick start guide and a safety and compliance statement.



The IF30 Out of the Box



Note: The IF30 does not ship with RFID antennas. For more information on these accessories, contact your Intermec sales representative.

What You Need

To install and connect the IF30, you need these items:

- An appropriate AC power cord
- Appropriate RFID antennas and cables
- An Ethernet cable

Learning About the IF30

This section explains the ports and LEDs on the IF30.

Understanding the Front Panel Ports

The IF30 front panel has four ports. To access three of the ports, you need to remove the cable access door.

To remove the access door

- On the underside of the IF30, unscrew the two thumbscrews on the cable access door and remove the door.

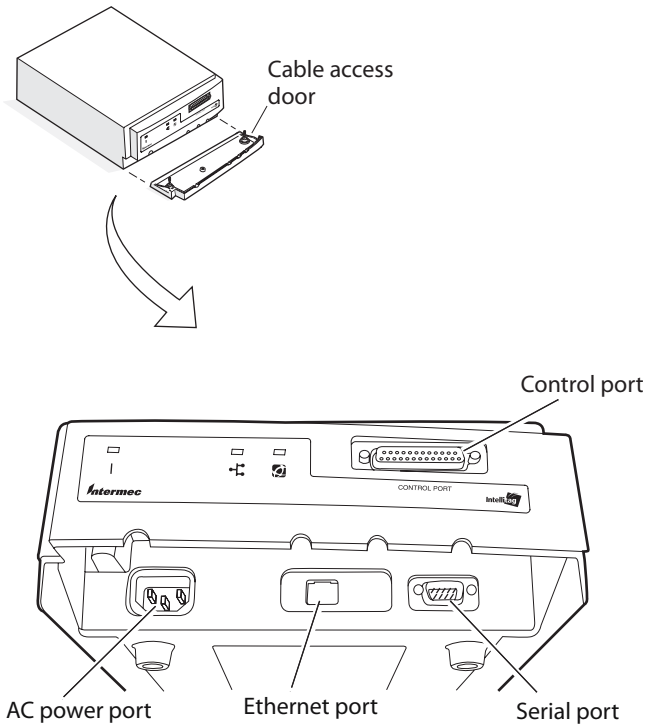

IF30 Front Panel Ports: This illustration shows how to remove the cable access door and where the ports are located.

IF30 Front Panel Port Descriptions

Port	Description
AC Power	Used with an appropriate power cable, this port connects the reader to an AC power source.
Ethernet	10BaseT/100BaseTx port. Used with an appropriate cable, this port connects the reader to your Ethernet network. The reader auto-negotiates with the device it is communicating with so that the data rate is set at the highest rate at which both devices can communicate.
Serial	Used with an RS-232 null modem cable (P/N 059167), this port connects the reader to a terminal or PC to perform configuration.
Control	General purpose input/output (GPIO) port. This port connects the reader to industrial controls such as relays or indicators. The port includes optically-isolated inputs, optically-isolated low voltage DC outputs, and access to 12 VDC. For more information on the IF30 GPIO interfaces, see “About the GPIO Interfaces” on page 72..

For more information, see “Port Pin Assignments” on page 82.

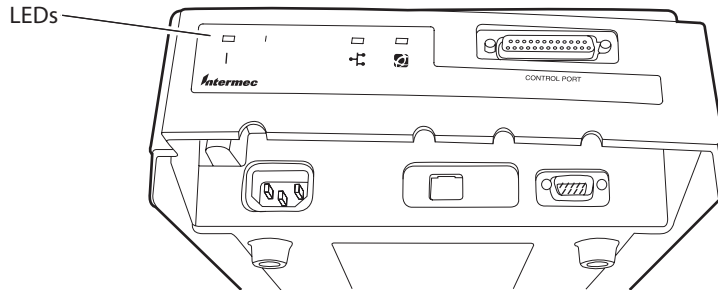

Understanding the LEDs

The IF30 has three LEDs that show you the operating status of the reader.



IF30 LEDs

LED Descriptions

LED Icon	LED Name	Description
	Power	Remains on after the IF30 boots.
	Wired LAN	Flashes when a frame is transmitted or received on the Ethernet port.
	Intermec Ready-to-Work™ Indicator	Blue LED remains on when an application is communicating with the data collection engine (DCE) on the IF30. Blinks when no application is communicating with the DCE. For more information, see the next section.

Learning About the Intermec Ready-To-Work Indicator

The blue Ready-to-Work Indicator shows when an application is communicating with the data collection engine (DCE) on the IF30. The next table explains the different states of the Ready-To-Work indicator.

Ready-to-Work Indicator Status Descriptions

Status	Description
Off	The IF30 is not yet ready for operation.
Blinking	The BRI server is running but no applications have connected to the BRI TCP port.
Steady	An application is communicating with the BRI server. Or, your custom application is communicating with the DCE.

For more information on the DCE, see “Configuring the Data Collection Engine” on page 48.

Understanding the Rear Panel Ports

The ports on the rear panel are used for connecting the IF30 to RFID antennas.

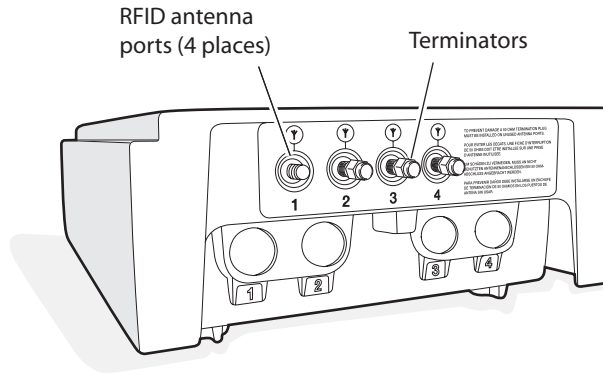

IF30 Rear Panel Ports: This illustration shows the ports on the rear panel. The IF30 ships with antenna terminators mounted on RFID antenna ports 2, 3, and 4.

The IF30 RFID antenna ports use these connectors:

- 865-869 MHz: SMA
- 915 MHz: Reverse SMA

Make sure you have appropriate antennas and cables for your IF30. For help, contact your Intermec sales representative.



Government regulatory agencies require that this RFID reader only use approved antennas. Therefore, this reader uses a custom antenna connector. Do not use antennas not approved for use with this reader.



Note: The IF30 ships with antenna terminators installed on RFID antenna ports 2, 3, and 4. Do not remove the terminator from any port unless you are installing an antenna or antenna cable on that port.

How the IF30 Fits in Your Network

In general, the reader forwards RFID tag data to the wired Ethernet network. The next illustrations show how the IF30 fits in your network.

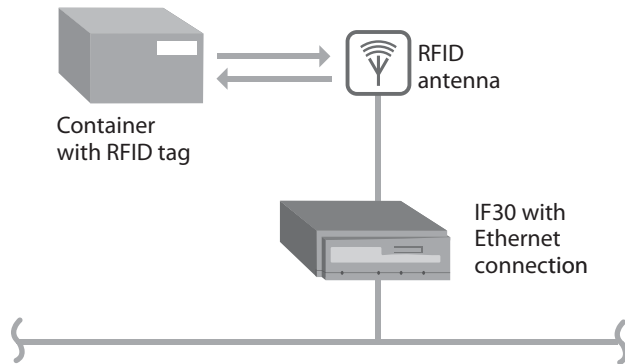

IF30 in a Wired Ethernet Network: This illustration shows the IF30 in a wired Ethernet network. The IF30 sends and receives RFID tag data to the RFID server through the wired network.

Configuring the IF30 (Setting the IP Address)

By default, the IF30 is configured to be a DHCP client and accepts offers from any DHCP server. Therefore, the IF30 will work directly out of the box.

However, if you are not using a DHCP server to assign an IP address you need to use a communications program, such as HyperTerminal, for the initial configuration. For help, see “Using a Communications Program” on page 10.

After the IF30 has been assigned an IP address, you can configure, manage, and troubleshoot the IF30 from a remote location using a web browser interface. For help, see “Using the Web Browser Interface” on page 14.



Note: This manual assumes that you are using a communications program for your initial configuration, and then using a web browser interface to perform all other configurations. You can also continue to use a communications program to configure the IF30.

Using a Communications Program

You can use a communications program (such as HyperTerminal) to set the initial IP address for the IF30. After you configure the IP address, you can continue to use the communications program to set other parameters or you can use a web browser to complete the configuration.

To use a communications program, you must have:

- a terminal or PC with an open serial port and the communications program.
- an RS-232 null-modem cable (P/N 059167). One end of this cable must be a 9-pin socket connector to connect to the serial port on the IF30. To order this cable, contact your local Intermec representative.



Note: If you have Microsoft ActiveSync running on your desktop PC, you may need to disable ActiveSync to make the serial port available.

To use a communications program

- 1 Use the RS-232 null-modem cable to connect the serial port on the IF30 to a serial port on your PC.
- 2 Start the communications program and configure the serial port communications parameters on your PC, and then click **OK**. You should configure the serial port communications parameters to:

Bits per second 9600

Data bits 8

Parity None

Stop bit 1

Flow control None

- 3 Connect the IF30 to AC power. The IF30 boots as soon as you apply power.

- 4 Press **Enter** when the message “Starting system” appears on your screen. The **Username** field appears.

```
IF30 RFID Reader Configuration
Copyright (c) 1995-2006 Intermec (R) Technologies
All rights reserved.

Ethernet IP:    10.10.101.53
Serial:        07200500013

Username:
```

- 5 In the **Username** field type the default user name `intermec`, and then press **Enter**.
- 6 In the **Password** field type the default password `intermec`, and then press **Enter**. The IF30 RFID Reader Configuration menu appears.

```
IF30 RFID Reader Configuration
[Ethernet]
[RFID Module]
[Network Services]
[Network Management]
[Security]
[Maintenance]
[Save Configuration]
[Reboot]

? Help
```

To configure the IF30 for your Ethernet connection, continue with the next procedure.

Configuring the IF30 for an Ethernet Connection

Follow this procedure to configure the IF30 for your Ethernet connection that does not use a DHCP server. If your wired network uses a DHCP server, you can skip this procedure and continue with “Connecting the IF30 to Your Network” on page 19.

To configure the IF30 for a wired Ethernet connection

- 1 Connect to the IF30 using a communications program. For help, see “Using a Communications Program” on page 10.

- 2 With **Ethernet** selected in the IF30 RFID Reader Configuration menu, press the right arrow. The Ethernet menu appears.



- 3 Configure these settings:

DHCP Mode	Set to Disable DHCP .
IP Address	A unique IP address.
IP Subnet Mask	The subnet mask that matches the other devices in your network.
IP Router (Gateway)	If the IF30 will communicate with devices on another subnet, enter the address of the router that will forward frames.

Or, press the down arrow key to select **IPv6 Configuration**, and then press the right arrow key to configure these IPv6 settings:

Enable Autoconfiguration	Enables automatic assignment of a unique address to this IF30.
IPv6 Address	A unique 128-bit IPv6 address.
IPv6 Subnet Mask	The IPv6 subnet mask. Range is 1 to 128 bits.
IPv6 Router (Gateway)	A unique 128-bit address for an IPv6 router.

- 4 (Optional) To configure DNS settings, choose **Network Services** and press **Enter**. The Network Settings screen appears.

```

[Network Services]
-----
Hostname      "if3007200500013"
Domain Name   "..."
DNS Address 1 "0.0.0.0"
DNS Address 2 "0.0.0.0"
DNS Suffix 1  "..."
DNS Suffix 2  "..."
[SNMP Configuration]
SYSLOG Destination "..."

```

Configure the DNS settings as needed:

Hostname Hostname for this IF30. The default is IF30 prepended to the serial number of the unit.

This can be a simple hostname or a fully qualified domain name (FQDN). If this device obtains its IP address via DHCP, this parameter is also sent to the DHCP server. If the DHCP server supports it, this field will be used for dynamic DNS (DDNS) updates.

DNS Address 1 IP address of a domain name server that the IF30 uses to resolve DNS names.

DNS Address 2 IP address of a domain name server that the IF30 uses to resolve DNS names if the DNS server at DNS Address 1 is not responding.

DNS Suffix 1 Domain name suffix that will be appended to DNS names that cannot be resolved.

DNS Suffix 2 Domain name suffix that will be appended to DNS names that cannot be resolved either by themselves or using DNS suffix 1.

- 5 Press the left arrow key to return to the main reader configuration menu.
- 6 Press the down arrow key to select **Save Configuration** and then press **Enter**. The new settings are saved.
- 7 Press the down arrow key to select **Reboot** and then press **Enter**. The IF30 reboots. When the boot process is finished, you see “Starting system...” at the bottom of the HyperTerminal screen.
- 8 Disconnect the null-modem cable and AC power cable from the IF30.

The IF30 is now ready to be connected to your network. See “Connecting the IF30 to Your Network” on page 19.

Using the Web Browser Interface

After you have set the initial IP address, you can configure and manage the IF30 remotely using the web browser interface. The IF30 web browser interface has been tested using Internet Explorer 6.0. Using other browsers may provide unpredictable results.

To use the web browser interface, the IF30 must be connected to your wired Ethernet.

If your session terminates abruptly or a new login screen appears, someone else may have accessed the IF30. When using the web browser interface, remember that your session terminates if you do not use it for 15 minutes.



Note: If you access the Internet using a proxy server, add the IF30 IP address to your Exceptions list. The Exceptions list contains the addresses that you do not want to use with a proxy server.

To use the IF30 web browser interface

- 1 Determine the IP address of the IF30. If a DHCP server assigned the IP address, you need to get the IP address from that server.
- 2 Start Internet Explorer.
- 3 In the **Address** field, enter the IP address, and press **Enter**. The IF30 login screen appears.

Security	Login credentials
<p>Note: This login session is not secure.</p> <p>A secure session is available</p> <p>Some features such as importing certificates are only available through the secure interface.</p> <p>To only allow secure login and avoid ever seeing this message, change the "Browser Access" option under the "Security" menu to "Secure-Only".</p>	<p>Username: <input type="text"/></p> <p>Password: <input type="password"/></p> <p><input type="button" value="Login"/></p> <p>Once you enter the correct user name and/or password, you will be logged fifteen minutes of inactivity you will be logged out.</p>

Copyright © 1995-2006 Intermec Technologies Corporation. All rights reserved.

Or, for a secure session, click **A secure session is available**. The secure login screen appears.

- 4 If necessary, enter a user name and password. The default user name is `intermec` and the default password is `intermec`. You can define the user name and password. For help, see “Setting Up Logins” on page 33.
- 5 Click **Login**. The Ethernet screen appears.

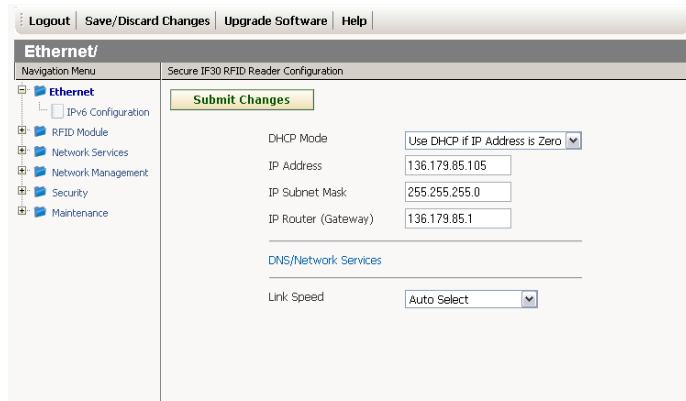

The screenshot shows a web browser interface for configuring the Ethernet settings of an IF30 RFID Reader. At the top, there are navigation tabs: Logout, Save/Discard Changes, Upgrade Software, and Help. Below this is a header bar with 'Ethernet/' and 'Secure IF30 RFID Reader Configuration'. A navigation menu on the left lists various configuration categories: Ethernet, IPv6 Configuration, RFID Module, Network Services, Network Management, Security, and Maintenance. The main configuration area features a yellow 'Submit Changes' button. Below the button, there are several input fields: 'DHCP Mode' with a dropdown menu set to 'Use DHCP if IP Address is Zero', 'IP Address' with the value '136.179.85.105', 'IP Subnet Mask' with '255.255.255.0', and 'IP Router (Gateway)' with '136.179.85.1'. There is also a section for 'DNS/Network Services' and a 'Link Speed' dropdown menu set to 'Auto Select'.

Your web browser session is established.



Note: Although you can use several methods to manage the IF30 remotely, this manual assumes you are using the web browser.

Saving Configuration Changes

When you are done configuring the IF30, you may want to activate your changes immediately or you may want to save the changes now and activate them later. If you choose to activate the changes later, they will become active the next time the IF30 is booted.



Note: If you made changes to RFID module settings, you need to reboot the IF30 to activate those changes.

IF30 Configuration Files

Configuration File	Description
Default	This configuration file is the factory default configuration. For help, see “Restoring the IF30 to the Default Configuration” on page 65.
Current	When you click Submit Changes , the IF30 updates the current configuration file. The IF30 does not change the active configuration file. You can see a list of pending changes when you click Save/Discard Changes . Having separate files for the current and active configurations lets you make changes while the IF30 is running without interrupting communication.
Active	When you click Save/Discard Changes > Save Changes and Reboot , the IF30 copies the current configuration file to the active configuration file. The active configuration file is the file that the IF30 uses.

To save or discard configuration changes

- 1 On the menu bar, click **Save/Discard Changes**.



The Save/Discard Changes screen appears.

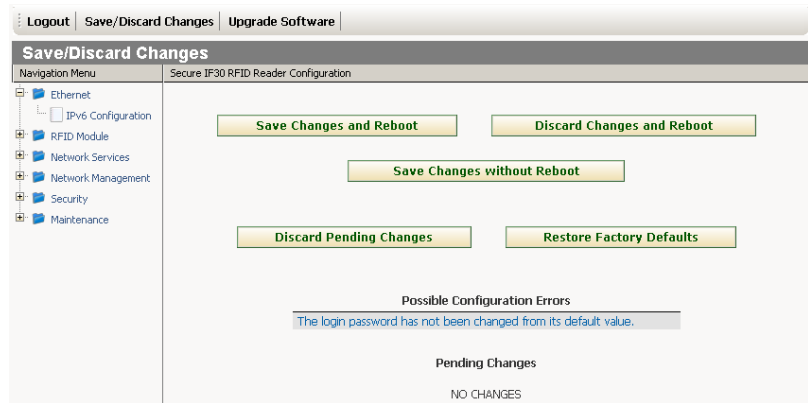

- 2 To discard changes, click **Discard Pending Changes**.
To save changes, continue with the next step.
- 3 Verify that all your configuration changes appear in the Pending Changes list.
- 4 Click **Save Changes and Reboot** to reboot the IF30 and immediately use your new active configuration.

Or, click **Save Changes without Reboot**. The IF30 saves the changes to its current configuration and continues to run its active configuration. You will need to reboot the IF30 when you want the current configuration to become the active configuration.

Installing the IF30

This section explains how to choose a mounting location for the IF30 and connect the IF30 to your wired Ethernet network.

Choosing a Mounting Location

You can place the IF30 horizontally or vertically on a stable surface. You can also mount the IF30 to a wall or a beam using one of these mounting bracket kits:

- Mounting bracket kit (P/N 068918)
- Rotating mounting bracket kit (P/N 068751)

For more information, contact your local Intermec representative.

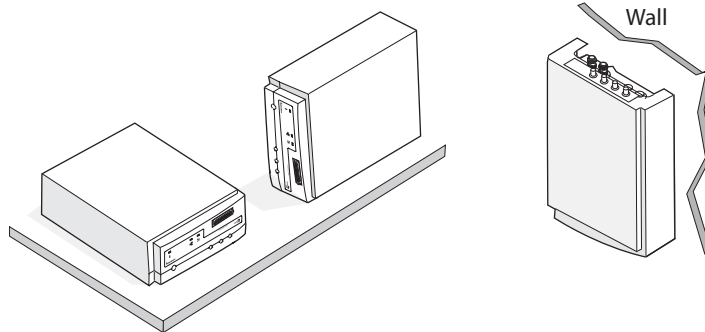

Mounting the IF30: This illustration shows the ways you can install the IF30 on a horizontal or vertical surface.

The next table includes environmental requirements for the IF30. Choose a location that meets these requirements.

IF30 Environmental Requirements

Type	Minimum	Maximum
Operating temperature	-25°C (-13°F)	55°C (131°F)
Storage temperature	-30°C (-22°F)	75°C (167°F)
Humidity (non-condensing)	10%	90%

Connecting the IF30 to Your Network

After you configure the IF30 for your network and choose a mounting location, you can place the IF30 in its mounting location and connect it to your network.

For help with configuring the IF30, see “Configuring the IF30 (Setting the IP Address)” on page 9.



Note: If there is no DHCP server available at boot time, the IF30 will not be able to communicate on the network while searching for DHCP lease offers.

To install the IF30

- 1 Remove the cable access door. For help, see “Understanding the Front Panel Ports” on page 4.
- 2 Attach one to four RFID antennas to the RFID antenna ports, starting with port 1. Do not remove the terminators from unused antenna ports. For help, see “Understanding the Rear Panel Ports” on page 8.



Warning

Each port must have either an antenna or a terminator connected. Do not apply power to the reader unless an antenna or terminator is installed on each antenna port.

- 3 Connect an Ethernet cable to the IF30 Ethernet port.
- 4 Connect the AC power cord to the power port on the IF30.



Note: The IF30 does not support power over Ethernet (POE).

- 5 Install the cable access door and route the cables through the openings in the door seam. Make sure the cables are not caught in the seam.
- 6 Place the IF30 in its mounting location. For more information, see “Choosing a Mounting Location” on page 18.
- 7 Connect the Ethernet cable to your network.

- 8 Connect the AC power cord to an AC outlet. As soon as you apply power, the IF30 boots and the green Power LED turns on.

The IF30 is now ready to communicate in your network.

Setting the Date and Time

After you have installed the IF30, you can set the date and time via the web browser interface.

To set the date and time

- 1 Connect to the IF30 via the web browser interface. For help, see “Using the Web Browser Interface” on page 14.
- 2 On the web browser screen, click the date and time in the upper right-hand corner.

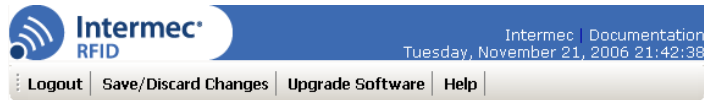

The Set Clock screen appears.

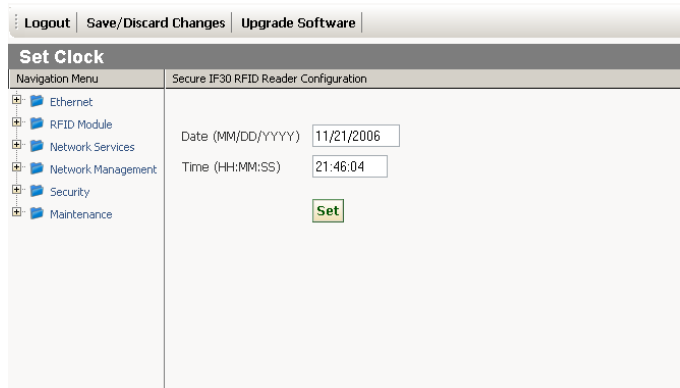

- 3 In the **Date** field, enter the current date using the format *MM/DD/YYYY*, where:

MM is the month.

DD is the date.

YYYY is the year.

- 4 In the **Time** field, enter the current time using the format *HH:MM:SS*, where:
 - HH* is the correct hour in UTC (24-hour) format.
 - MM* is the correct minute.
 - SS* is the correct second.
- 5 Click **Set**. The IF30 date and time are set.

Using the IF30 Securely

You can protect the integrity and security of your data on the IF30 by using a secure web browser session (HTTPS) to access the IF30. For help, see “Using the Web Browser Interface” on page 14.



2 Configuring Network Settings

This chapter describes how to configure network settings for the IF30 and includes these topics:

- Configuration Settings For Your Network
- Configuring Ethernet Settings
- Configuring Network Services
- Configuring Security
- About Certificates

Configuration Settings For Your Network

This chapter assumes that you are using the IF30 web browser interface to configure network settings on the IF30. For help, “Using the Web Browser Interface” on page 14.

You can also configure network settings by:

- using a communications program to access the IF30. For help, see “Using a Communications Program” on page 10.
- using Intermecc Settings from within the Intermecc SmartSystems Console. For help, see “Using Intermecc SmartSystems Foundation” on page 54.

Configuring Ethernet Settings

This section explains how to configure the wired Ethernet settings using the web browser interface:

- DHCP mode
- (If DHCP is enabled) DHCP server name, user class, and vendor class
- IP address
- IP subnet mask
- IP router (gateway)
- Link speed



Note: If you are using a DHCP server, you may not need to configure Ethernet settings. For more information, contact your network administrator.

For help with enabling IPv6 and configuring settings, see “Enabling IPv6” on page 27.

To configure Ethernet settings

- 1 From the menu, click **Ethernet**. The Ethernet screen appears.

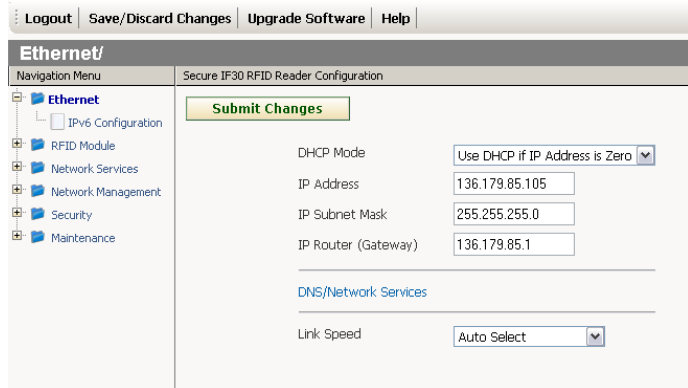

The screenshot shows the 'Ethernet' configuration page. At the top, there are navigation links: 'Logout', 'Save/Discard Changes', 'Upgrade Software', and 'Help'. Below this is a header bar with 'Ethernet/' and 'Secure IF30 RFID Reader Configuration'. A 'Navigation Menu' on the left lists: Ethernet (selected), IPv6 Configuration, RFID Module, Network Services, Network Management, Security, and Maintenance. A 'Submit Changes' button is prominent. The main configuration area includes: 'DHCP Mode' (dropdown menu set to 'Use DHCP if IP Address is Zero'), 'IP Address' (text box with '136.179.85.105'), 'IP Subnet Mask' (text box with '255.255.255.0'), 'IP Router (Gateway)' (text box with '136.179.85.1'), a section for 'DNS/Network Services', and 'Link Speed' (dropdown menu set to 'Auto Select').

- 2 Configure the Ethernet settings. For help, see the next table.



Note: Different settings appear in this screen depending on the current DHCP mode for the IF30.

If you need to configure DNS/Network Services settings, such as DNS addresses or suffixes, or a SYSLOG destination, see “Configuring Network Services” on page 28.

- 3 Click **Submit Changes** to save your changes. To activate your changes, from the menu bar click **Save/Discard Changes**, and then click **Save Change and Reboot**. For help, see “Saving Configuration Changes” on page 15.

Ethernet Setting Descriptions

Parameter	Description
DHCP Mode	<p>Sets the DHCP mode for the IF30:</p> <ul style="list-style-type: none"> Choose Always Use DHCP if you want the IF30 to get its IP address from a DHCP server. Choose Use DHCP if IP Address is Zero if you want the IF30 to use DHCP whenever its IP address is set to 0.0.0.0. If you choose this option, make sure the IP address is set to 0.0.0.0. Choose Disable DHCP if you want to assign a static IP address to the IF30.
DHCP Server Name	Name of the DHCP server. The IF30 accepts lease offers from only this server.
DHCP User Class	(Optional) User class for this DHCP server.
DHCP Vendor Class	(Optional) Vendor class for this DHCP server.
IP Address	<p>IP address of the IF30 Ethernet connection. The IP address has the form <i>x.x.x.x</i>, where <i>x</i> is a number from 0 to 255.</p> <p>Set this value to 0.0.0.0 if you set the DHCP Mode to Use DHCP if IP Address is Zero.</p> <p>Set this value to a static IP address for the Ethernet connection if you disabled DHCP.</p>
IP Subnet Mask	Subnet mask for this network. The subnet mask has the form <i>x.x.x.x</i> , where <i>x</i> is a number from 0 to 255.
IP Router (Gateway)	IP address of the router. The IP address has the form <i>x.x.x.x</i> , where <i>x</i> is the number from 0 to 255.
Link Speed	<p>Choose the speed and duplex mode you want the IF30 to use when it communicates with the Ethernet network.</p> <p>If you want the IF30 to auto-negotiate this field, choose Auto Select. Auto Select should work for most networks.</p>

Enabling IPv6

- 1 To enable IPv6 for your Ethernet connection, in the menu click **Ethernet > IPv6 Configuration**.
- 2 Check the check box to enable IPv6, or uncheck the check box to disable IPv6.
- 3 Click **Submit Changes** to save your changes. The IPv6 Configuration screen appears.
- 4 If you want to enable IPv6 autoconfiguration, click **Enable Autoconfiguration** and continue with Step 5.
If you do not want to enable IPv6 autoconfiguration:
 - a Click **Submit Changes**. The screen refreshes with a list of IPv6 configuration settings.
 - b Configure IPv6 settings. For help, see the next table.
- 5 Click **Submit Changes**. To activate your changes, from the menu bar click **Save/Discard Changes**, and then click **Save Changes and Reboot**. For help, “Saving Configuration Changes” on page 15.

IPv6 Settings Descriptions

Parameter	Description
IPv6 Address	A unique 128-bit IPv6 address.
IPv6 Subnet Mask	The IPv6 subnet mask. Range is 1 to 128 bits.
IPv6 Router (Gateway)	A unique 128-bit address for an IPv6 router.

Configuring Network Services

This section explains how to configure these network service settings using the web browser interface:

- Hostname
- Domain Name Server (DNS) addresses 1 and 2
- DNS suffixes 1 and 2
- SYSLOG destination

To configure network services

- 1 From the menu, click **Network Services**. The Network Services screen appears.

The screenshot shows the 'Network Services' configuration page. At the top, there is a navigation bar with links for 'Logout', 'Save/Discard Changes', 'Upgrade Software', and 'Help'. Below this is a header for 'Network Services/' and a sub-header 'IF30 RFID Reader Configuration'. A left-hand navigation menu lists various settings: Ethernet, RFID Module, Network Services (selected), SNMP Configuration, Network Management, Security, and Maintenance. The main content area features a green 'Submit Changes' button at the top. Below it are several input fields: 'Hostname' (containing 'if3006200500224'), 'Domain Name' (empty), 'DNS Address 1' (containing '0.0.0.0'), 'DNS Address 2' (containing '0.0.0.0'), 'DNS Suffix 1' (empty), 'DNS Suffix 2' (empty), and 'SYSLOG Destination' (empty).

- 2 Configure settings. For help, see the next table.
- 3 Click **Submit Changes** to save your changes. To activate your changes, from the menu bar click **Save/Discard Changes**, and then click **Save Changes and Reboot**. For help, see “Saving Configuration Changes” on page 15.

IPv6 Settings Descriptions

Parameter	Description
Hostname	Name for this device. The default is the configuration string for this IF30. The hostname can be either a simple hostname, or a qualified domain name (FQDN). If this device obtains its IP address via DHCP, this parameter is sent to the DHCP server. If the server supports it, this field is used for dynamic DNS updates.
DNS Address 1	Enter the IP address of a domain name server that the IF30 uses to resolve DNS names.
DNS Address 2	Enter the IP address of a domain name server that the IF30 uses to resolve DNS names if the DNS server at DNS Address 1 is not responding.
DNS Suffix 1	Enter a domain name suffix that will be appended to DNS names that cannot be resolved.
DNS Suffix 2	Enter a domain name suffix that will be appended to DNS names that cannot be resolved either by themselves or using DNS suffix 1.
SYSLOG Destination	Domain name or IP address of the SYSLOG server. In Unix networks, system messages are logged to this server.

Configuring SNTP Client Settings

This section explains how to configure Simple Network Time Protocol (SNTP) client parameters. For information on public NTP servers, see <http://ntp.isc.org>.

To configure SNTP settings

- 1 From the menu, click **Network Services > SNTP Configuration**. The SNTP Configuration screen appears.

The screenshot shows the 'SNTP Configuration' screen. At the top, there is a navigation bar with buttons for 'Logout', 'Save/Discard Changes', 'Upgrade Software', and 'Help'. Below this is a header for 'Network Services/SNTP Configuration/'. The main area is split into two columns. The left column is a 'Navigation Menu' with a tree view containing 'Ethernet', 'RFID Module', 'Network Services' (expanded), 'SNTP Configuration' (selected), 'Network Management', 'Security', and 'Maintenance'. The right column is titled 'Secure IF30 RFID Reader Configuration' and contains a 'Submit Changes' button, followed by three input fields: 'SNTP Server Name 1', 'SNTP Server Name 2', and 'Time Zone' (with a dropdown menu showing '0').

- 2 Enter SNTP information: In the **SNTP Server Name 1** and **SNTP Server Name 2** fields, enter the DNS name or the IP address of an SNTP or NTP server.
- 3 Click **Submit Changes** to save your changes. To activate your changes, from the menu bar click **Save/Discard Changes**, and then click **Save Changes and Reboot**. For help, see “Saving Configuration Changes” on page 15.

Configuring Security

The IF30 supports security features to help maintain the integrity of your secure network. You can:

- enable/disable access methods. For help see the next section “Controlling Access to IF30 Menus.”
- change the default user name and password. For help, see “Setting Up Logins” on page 33.

- use a password server to maintain a list of authorized users who can configure and manage the IF30. For help, see “Setting Up Logins” on page 33.

Controlling Access to IF30 Menus

You can enable or disable the web browser interface (HTTP or HTTPS) depending on how you want users to be able to configure or manage the IF30. For help, see “Access Method Descriptions” on page 32.

To enable or disable the web browser interface

- 1 From the menu, click **Security**. The Security menu appears.

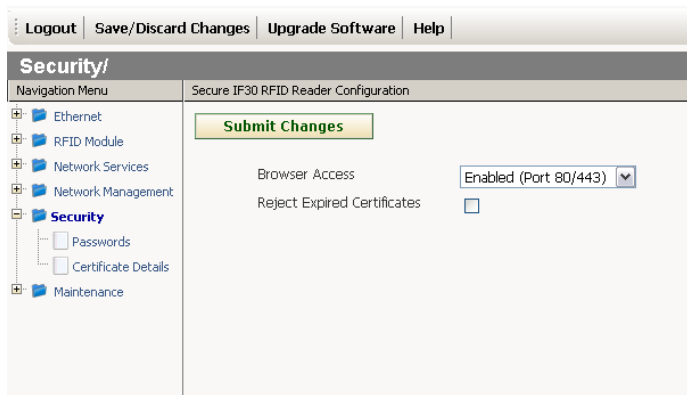

- 2 Enable or disable the web browser interface
- 3 Click **Submit Changes** to save your changes. To activate your changes, from the menu bar click **Save/Discard Changes**, and then click **Save Changes and Reboot**. For help, see “Saving Configuration Changes” on page 15.

Access Method Descriptions

Method	Description
Browser Access	<p>Determines if users can use a web browser to configure or manage the IF30. Browser access is through port 80 or port 443.</p> <p>Choose Secure-Only if you want users to log in only using the secure web browser (HTTPS) interface. Secure-Only access is through port 443.</p> <p>If you disable browser access to the IF30, you may need to use a communications program to configure and manage the IF30. For help, see “Using a Communications Program” on page 10.</p>
Reject Expired Certificates	<p>Check this check box if you want the IF30 to reject certificates that have expired. For help, see “Rejecting Expired Certificates” on page 39.</p>

Setting Up Logins

To ensure login security for configuring or maintaining the IF30, you should use a password server or change the default user name and password.

A password server is typically an embedded authentication server (EAS) or other RADIUS server. To use a password server, you must have a password server on the network that contains the user name/password database. On the IF30, you need to enable RADIUS for login authorization.

When a user attempts to log in to the IF30, the user must enter a user name and password. This login is sent to the RADIUS server, which compares the login to its list of authorized logins. If a match is found, the user can log in to the IF30 with read/write privileges.

If no RADIUS server is available when the user tries a login and the **Allow Service Password** check box is checked, the server checks the service password. If the login does not match the service password, the login fails.

For help, see the next section, “Configuring the IF30 to Use a Password Server.”

If you do not want to use a password server, you should change the default login user name and password, and create a read-only password. For help, see “Changing the Default Login” on page 35.

Configuring the IF30 to Use a Password Server

If you use a password server to manage users who can log in to this IF30, you need to tell the IF30 how to communicate with the password server and then you need to configure the password server.

To configure the IF30 to use a password server

- 1 From the menu, click **Security > Passwords**. The passwords screen appears.

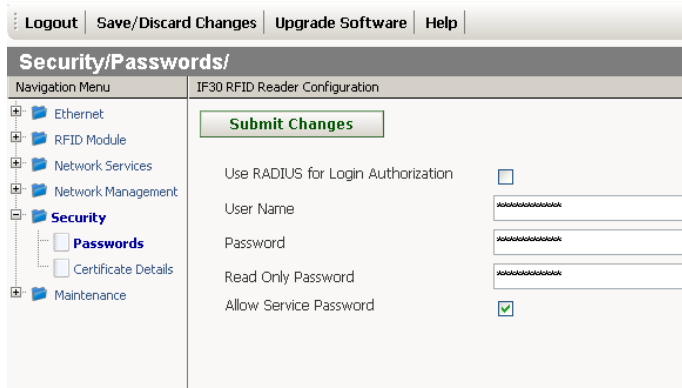

- 2 Check the **Use RADIUS for Login Authorization** check box.
- 3 Click **Submit Changes** to save your changes.
- 4 Click **Select a RADIUS Server for Login Authorization**. The RADIUS Server List screen appears.

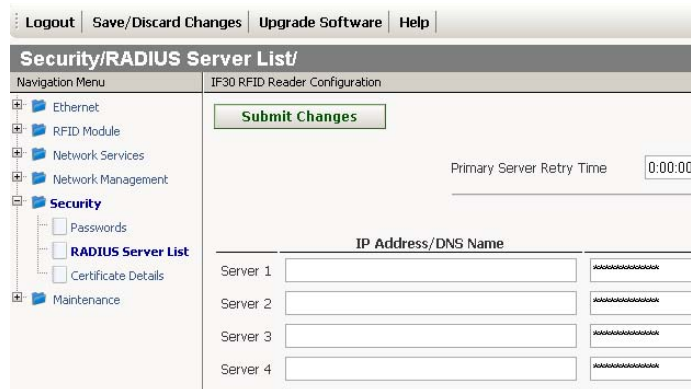



- For each password server, enter the IP address or the DNS name, enter the shared secret key and port number.

Note: If you enter more than one password server, the other password servers act as backup servers. The IF30 uses the first password server (starting with Server 1) whose IP address/DNS name and secret key are the same as the one in the list.

- Configure the password server database. For help, see the documentation that came with your server.

Changing the Default Login

If you are not using a password server to authorize user logins, Intermec recommends that you change the default user name and password and create a read-only password.

To set up logins

- From the main menu, click **Security > Passwords**. The Passwords screen appears.

The screenshot shows the 'Security/Passwords/' configuration page. At the top, there are tabs for 'Logout', 'Save/Discard Changes', 'Upgrade Software', and 'Help'. Below the tabs is a navigation menu with options like Ethernet, RFID Module, Network Services, Network Management, Security, and Maintenance. The 'Security' menu is expanded to show 'Passwords' and 'Certificate Details'. The main content area is titled 'IF30 RFID Reader Configuration' and features a green 'Submit Changes' button. Below the button are four configuration items: 'Use RADIUS for Login Authorization' with an unchecked checkbox, 'User Name' with a masked input field, 'Password' with a masked input field, 'Read Only Password' with a masked input field, and 'Allow Service Password' with a checked checkbox.

- Clear the **Use RADIUS for Login Authorization** check box.
- Click **Submit Changes** to save your changes.
- Configure the parameters. For help, see the next table.
- Click **Submit Changes** to save your changes. To activate your changes, from the menu bar click **Save/Discard Changes**, and then click **Save Changes and Reboot**.

For help, see “Saving Configuration Changes” on page 15.

Password Parameter Descriptions

Parameter	Descriptions
Use RADIUS for Login Authorization	Determines if you are using a password server to authenticate logins to this IF30. Uncheck this check box if you are not using a password server.
User Name	Enter the user name you need to use to log in to this IF30. The user name can be from 0 to 32 characters long. If you leave the user name and password fields blank, a user will not need to log in to the IF30.
Password	Enter the password you use to log in to this IF30. This password gives you read and write access to the IF30 configuration. The password can be from 0 to 32 characters long. If you leave the user name and password fields blank, a user will not need to log in to the IF30.
Read Only Password	Enter the password you need to use to log in to this IF30. This password gives the user read-only access to the IF30. This user can view the configuration and execute diagnostics but cannot perform any tasks that affect IF30 operation, such as changing configuration options or downloading software. To disable this password, delete it.
Allow Service Password	If the user enters a login that does not match either the user name and password or the read only password, this setting (enabled by default) allows the login to be checked against the service password. Intermec Product Support may use this service password if they need to troubleshoot this IF30. If this feature violates your security guidelines, you may disable the service password by unchecking the check box. If you disable the service password and forget your normal password, you will need to contact Product Support for instructions on resetting all passwords to default values.

About Certificates

The default server certificate on the IF30 (ValidForHTTPSONLY) supports the secure web browser interface. You can use a third-party CA to issue unique client certificates and a root certificate.

Viewing Certificates

You can use the web browser interface to view the certificates loaded on the IF30.

To view certificates

- From the menu, click **Security > Certificate Details**. The Certificate Details screen appears.

The screenshot shows the 'Security/Certificate Details' page in the IF30 RFID Reader Configuration web interface. The page has a navigation menu on the left and a main content area on the right. The main content area contains two tables: 'Server Certificate' and 'CA Certificate'.

Server Certificate	
Status	Default
Common Name(CN)	ValidForHTTPSONLY
Issuer Common Name(CN)	Intermec Technologies Corporation Root Certificate
Valid From	Oct 30 12:50:50 2002 GMT
Valid To	Oct 30 12:50:50 2037 GMT

CA Certificate	
Status	Installed
Common Name(CN)	Intermec Technologies Corporation Root Certificate
Issuer Common Name(CN)	Intermec Technologies Corporation Root Certificate
Valid From	Jul 3 18:58:05 2002 GMT
Valid To	Jul 3 18:58:05 2037 GMT

The Server Certificate table lists the server certificate that is installed, and the CA certificate table lists the trusted CA certificate that is installed.

Installing and Uninstalling Certificates

Once you have determined that you need to install or uninstall a certificate, use this procedure.



Note: If you uninstall all certificates, you lose the unique server certificate and the trusted CA certificate. You need to contact your local Intermec representative to purchase new certificates.

To install certificates

- 1 Click **Install certificates in the certificates store**. The Certificate Import screen appears.



Note: If you are not using a secure web browser, you will be prompted to log in again. Click **A secure session is available** and log in to the IF30. If a Security Alert dialog box appears, click **Yes** to proceed. Repeat the above procedure.

- 2 Click **Server Certificate** or **Trusted CA Certificate**.
- 3 In the **Enter or select the name of the certificate file to import** field, enter the path to and filename of the server certificate. Or click **Browse** to find the certificate.
- 4 (Server Certificate only) In the **Enter the associated passphrase for this certificate** field, carefully enter the passphrase for the certificate.
- 5 Click **Import Certificate**. If a Security Alert dialog box appears, click **Yes** to proceed.

To uninstall certificates

- 1 From the main menu, click **Security > Certificate Details**. The Certificate Details screen appears.
- 2 To uninstall certificates, click **Uninstall all certificates**. The unique server certificate and the trusted CA certificate are deleted. You can still use the secure web browser interface and install new certificates using the default certificate (ValidForHTTPSONly).

Rejecting Expired Certificates

By default, when you install a certificate the IF30 does not validate the certificate dates against the date currently set in the IF30 operating system. Follow the next procedure to set the IF30 to reject expired certificates.

To set the IF30 to reject expired certificates

- 1 From the menu, click **Security**. The Security screen appears.

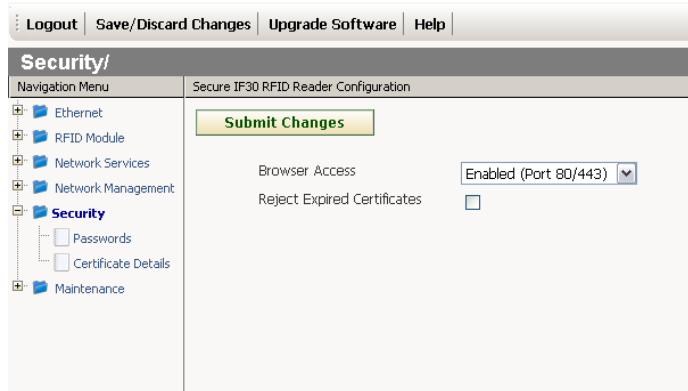

- 2 Check the **Rejected Expired Certificates** check box.
- 3 Click **Submit Changes** to save your changes. To activate your changes, from the menu bar click **Save/Discard Changes**, and then click **Save Changes and Reboot**. For help, see “Saving Configuration Changes” on page 15.



3 Creating and Using RFID Applications

This chapter explains how you can use RFID applications for the IF30 and includes these topics:

- RFID Applications and the IF30
- Creating Applications for the IF30
- Configuring RFID Settings
- Configuring the Data Collection Engine

RFID Applications and the IF30

An RFID application communicates with the IF30 through the Data Collection Engine (DCE), and controls the reader by issuing Basic Reader Interface (BRI) commands.

- For more information on the DCE, see “Configuring the Data Collection Engine” on page 48.
- For more information on the BRI, see the *Basic Reader Interface Programmer’s Reference Manual* (P/N 937-000-xxx).

Creating Applications for the IF30

An RFID application can communicate directly with the IF30 DCE using the BRI protocol. For more information, see “Configuring the Data Collection Engine” on page 48.

To develop RFID applications for the IF30, you will need to write and test your RFID applications on a development workstation (your desktop PC). The application can access the IF30 via TCP on port 2189.

Configuring RFID Settings

This section explains how you use the web browser interface to change the settings for the IF30 RFID module. As you install and test applications, you can configure the RFID settings for the best system performance.

To change RFID module settings

- 1 From the menu, click **RFID Module**. The RFID Module screen appears.

Intermecc RFID
Tuesday, January 23, 2007 16:3

Logout Save/Discard Changes Upgrade Software Help

RFID Module/

Navigation Menu IF30 RFID Reader Configuration

Submit Changes

Supported Tag Type (ISO)	None
Supported Tag Type (Gen 2)	EPC Class 1 Gen2
Dense Reader Mode	<input type="checkbox"/>
LBT Channel	5
LBT Scan Enable	<input checked="" type="checkbox"/>
Field Separator	Space ()
ID Report	<input checked="" type="checkbox"/>
No Tag Report	<input checked="" type="checkbox"/>
Timeout Configuration Mode	<input type="checkbox"/>
ID Tries	3
Antenna Tries	1
Report Timeout	0
Read Tries	3
Write Tries	3
Initialization Tries	1
Lock Tries	3
Select Tries	1
Unselect Tries	1

- 2 Change RFID settings as needed. For help, see the next section.
- 3 Click **Submit Changes** to save your changes. To activate your changes, from the menu bar click **Save/Discard Changes**, and then click **Save Changes and Reboot**. For help, see “Saving Configuration Changes” on page 15.



Note: If you make changes to RFID settings, you need to reboot the IF30 to activate the changes.

About RFID Module Settings

This section explains the module settings. Most settings have BRI attribute equivalents. For more information, see the *Basic Reader Interface Programmer's Reference Manual* (P/N 937-000-xxx).

Supported Tag Type

Sets the type of tag for RFID operations. Certain performance improvements can be realized if you choose the best setting for your system. The more specific the selection, the better the performance. See the next table for more information.

Tag Type Descriptions

Tag Type	Description
Phillips v1.19	Phillips v1.19
ISO6B/G1	ISO6B Generation 1
ISO6B/G2	ISO6B Generation 2
EPC Class 1 Gen 2 (default)	EPCglobal Class 1 Gen 2

This setting is equivalent to the TAGTYPE BRI attribute.

Supported Tag Type (Gen 2)

Enables or disables Gen 2 tag support for RFID operations. Choose **EPC Class 1 Gen 2** (default) to enable Gen 2 support, or **None** to disable Gen 2 support.

Dense Reader Mode

Check this check box to enable Dense Reader mode, which is only supported by EPC Class 1 Gen 2 tags. When dense reader mode is enabled, these tags respond with Miller Sub carrier encoded data instead of FM0 encoded data.

This setting is equivalent to the DENSEREADERMODE BRI attribute.

LBT Channel

(Supported only by 865 MHz readers) Sets the default transmit channel (of the 10 ETSI 302-208 channels) when the Listen Before Talk algorithm is enabled. Range is 1 to 10. Default channel is 5. The setting is used only when the LBT Scan Enable check box is not checked.

This setting is equivalent to the LBTCHANNEL BRI attribute.

LBT Scan Enable

(Supported only by 865 MHz readers) Enables ETSI 302-208 channel scanning when the Listen Before Talk algorithm is enabled.

When this check box is checked, the LBT algorithm looks for a free transmit channel among the 10 available ETSI 302-208 channels. When this check box is not checked, the transmit channel is set by LBT Channel.

This setting is equivalent to the LBTSCANENABLE BRI attribute.

Field Separator

Sets the space character to be used for separating fields in tag data. Choose either space () or comma (,). Default is space.

This setting is equivalent to the FIELDSEP BRI attribute.

ID Report

Enables or disables tag ID reporting after a Read, Write, or Lock command is executed:

- For ISO tags, the tag identifier corresponds to TAGID.
- For EPC tags, the tag identifier corresponds to EPCID.

Check the check box to enable tag ID reporting.

This setting is equivalent to the IDREPORT BRI attribute.

No Tag Report

Enables or disables a NOTAG message, which is sent when no tags are found during execution of a Read, Write, or Lock command. Check the check box to enable the message.

This setting is equivalent to the NOTAGRPT BRI attribute, and is enabled by default.

Timeout Configuration Mode

Enables a timeout mode. Instead of specifying the number of antenna or ID tries, you specify a timeout value. If the IF30 does not find any tags after an antenna or ID try, the reader waits for the specified time before starting the next antenna or ID try.

This setting is equivalent to the TIMEOUTMODE BRI attribute, and is disabled by default.

To enable Timeout Configuration Mode

- 1 Check the check box and then click **Save Changes**. The screen refreshes. The Antenna Tries setting is replaced by Antenna Timeout, and the ID Tries setting is replaced by the ID Timeout.
- 2 Specify the value (in ms) for the timeout in the entry fields and then click **Save Changes**.

ID Tries

Sets the maximum number of times the reader executes the identify algorithm before a response is returned to a Read or Write command.

In practice, this is the number of times a tag ID attempt is made for each antenna being used. Valid range is 1 to 254. Default is 3.

This setting is equivalent to the IDTRIES BRI attribute.

Antenna Tries

Sets the maximum number of ID Tries that the reader executes per antenna. Valid range is 1 (default) to 254.

This setting is equivalent to the ANTTRIES BRI attribute.

Read Tries

Sets the maximum number of times the read algorithm is executed before a response is returned to a Read command.

In practice, this is the number of times an identified tag will be read until the read is successful. Valid range is 1 (default) to 254.

This setting is equivalent to the RDTRIES BRI attribute.

Write Tries

Sets the maximum number of times the write algorithm is executed before a response is returned to a Write command.

In practice, this is the number of times an identified tag will be written until the write is successful. Valid range is 1 to 254. The default is 3.

This setting is equivalent to the WRTRIES BRI attribute.

Initialization Tries

Sets the maximum number of times the reader attempts to initialize a tag. Valid range is 1 (default) to 254.

This setting is equivalent to the INITTRIES BRI attribute.

Lock Tries

Sets the maximum number of times the lock algorithm is executed before a response is returned to a Lock command. Valid range is 1 to 254. The default is 3.

This setting is equivalent to the LOCKTRIES BRI attribute.

Select Tries

(Not supported by EPCglobal Class 1 Gen 2 tags) Sets the number of times a group select is attempted. A group select is the command that starts the identity process. Valid range is 1 (default) to 254.

This setting is equivalent to the SELTRIES BRI attribute.

Unselect Tries

(Not supported by EPCglobal Class 1 Gen 2 tags) Sets the number of times a group unselects is attempted. Valid range is 1 (default) to 254.

This setting is equivalent to the UNSELTRIES BRI attribute.

Initial Queue

(EPCglobal Class 1 Gen 2 tags only) Sets the initial Q parameter value used by the Query command. Valid range is 0 to 15. The default is 4. If you know there is only one tag in the field, set this attribute to 0 for best performance.

This setting is equivalent to the INITIALQ BRI attribute.

Session

(EPCglobal Class 1 Gen 2 tags only) Sets the command session parameter to the corresponding EPCglobal Class 1 Gen 2 air protocol command (default is QueryAdjust).

This setting is equivalent to the SESSION BRI attribute. For more information on this setting, see the EPCglobal Class 1 Gen 2 documentation.

Field Strength

Sets the RF power level (measured as a percentage of maximum power) for all antennas. Valid range is 1 to 100 (default).

Use this setting to attenuate the antenna field strength. In some situations, full output power can cause unnecessary interference. For example, if the tag is close to the antenna, full output power might overload the tag and cause unreliable behavior.

This setting is equivalent to the FIELDSTRENGTH BRI attribute.

Enable Antenna Port *n*

Enables or disables the antenna connected to antenna port *n*. Check the check box to enable that antenna. Antenna Port 1 is enabled by default.

If more than one antenna is enabled, the antennas always fire in sequence numerically (1, 2, 3, 4). To change this sequence, you need to set the ANTS BRI attribute. For more information, see the BRI programmer's reference manual.

Configuring the Data Collection Engine

The IF30 data collection engine (DCE) handles communication between your application and the RFID module. It allows up to 10 applications to use the same reader simultaneously.

When your application is communicating with the DCE, the blue Intermec Ready-to-Work Indicator on the IF30 front panel turns on and stays on. For help, see “Learning About the Intermec Ready-To-Work Indicator” on page 7.

You can configure many settings for the DCE. For help, see the next procedure.

To configure DCE settings

- 1 From the menu, click **RFID Module > DCE Configuration**. The DCE Configuration screen appears.

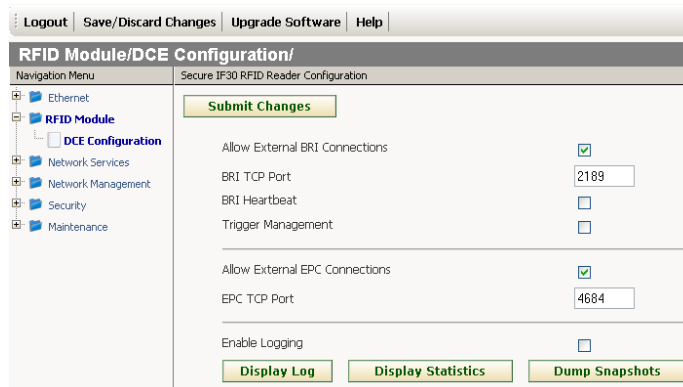

- 2 Change DCE settings as needed. For help, see the next table.

- 3 Click **Submit Changes** to save your changes. To activate your changes, from the menu bar click **Save/Discard Changes**, and then click **Save Changes and Reboot**. For help, see “Saving Configuration Changes” on page 15.

DCE Configuration Parameter Descriptions

Parameter	Description
Allows External BRI Connections	Enables/disables external TCP connections to the DCE BRI server.
BRI TCP Port	Specifies the TCP port used for incoming BRI connections to the DCE. This port must be unique for all TCP services running on the IF30. Valid range is 0 to 65535. Default is 2189.
BRI Heartbeat	Enables/disables asynchronous heartbeat event (EVT: HEARTBEAT BRI STRING). When enabled, the IF30 sends the heartbeat event every 30 seconds, enhancing the IF30’s ability to detect TCP sessions that were not closed cleanly.
Trigger Management	Enables DCE control of trigger states. When Trigger Management is enabled, the DCE manages the triggers so your application never needs to issue a TRIGGERREADY command. When Trigger Management is disabled, your application must manage issuance of the TRIGGERREADY command.
Allow External EPC Connections	Enables/disables external TCP connections to the DCE EPC server. When this box is not checked, the DCE accepts EPC connections only from applications residing on the IF30.
EPC TCP Port	Specifies the TCP port used for incoming EPC Reader Protocol connections to the DCE. This port number must be unique for all TCP services running on the IF30. Valid ranges is 0 to 65535. Default is 4684.
Enable Logging	Enables/disables logging of commands sent and received through the DCE.

Viewing the DCE Events Log

If you enable DCE logging, you can see a list of commands sent and received through the DCE. You can save the logfile as a .txt file.

To enable DCE logging and view the logfile

- 1 From the menu, click **RFID Module > DCE Configuration**. The DCE Configuration screen appears.
- 2 Check the **Enable Logging** check box.
- 3 Click **Submit Changes** to save your changes. To activate your changes, from the menu bar click **Save/Discard Changes**, and then click **Save Changes and Reboot**. For help, see “Saving Configuration Changes” on page 15.
- 4 After the IF30 reboots, click **Refresh** in the browser menu. The login screen appears.
- 5 Enter your user name and password, and then click **Login**. The TCP/IP Settings screen appears.
- 6 From the menu, click **RFID Module > DCE Configuration**. The DCE configuration screen appears.
- 7 Click **Display Log**, the DCE Configuration/Display Log screen appears with a list of command events.

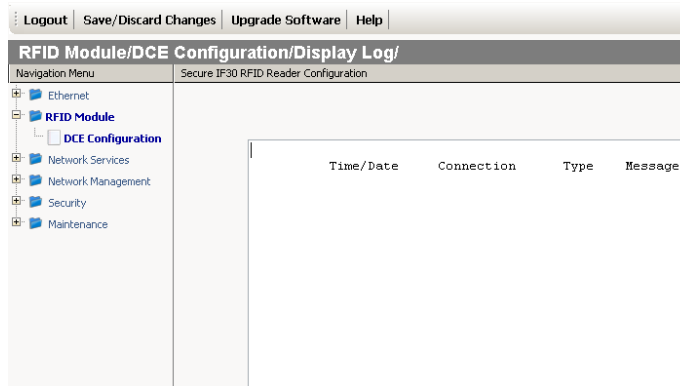

- 8 To save the log file, click **Download Logfile** and then choose **File > Save As**. Follow the prompts to save the log file to your desktop PC.

DCE Log Command Event Descriptions

Event Name	Description
Time/Date	Time and date of the event.
Connection	TCP port of the event. 0 indicates a serial connection.
Type	Message type of the event, generally indicating which system sent the message: 1 - Message from the RFID module to the DCE. 2 - Message from the DCE to the RFID Module. 3 - Message from the application to the DCE. 4 - Messages from the DCE to the application. Types 1 and 2 are suffixed by the message checksum value used by the reader module to detect errors.
Message	Text of the message, including responses.

Viewing DCE Statistics

You can use the web browser interface to view a list of DCE statistics.

To view DCE statistics

- 1 From the menu, click **RFID Module > DCE Configuration**. The DCE Configuration screen appears.
- 2 Click **Display > Statistics**. The DCE Configuration/Display Statistics screen appears with a list of DCE statistics.

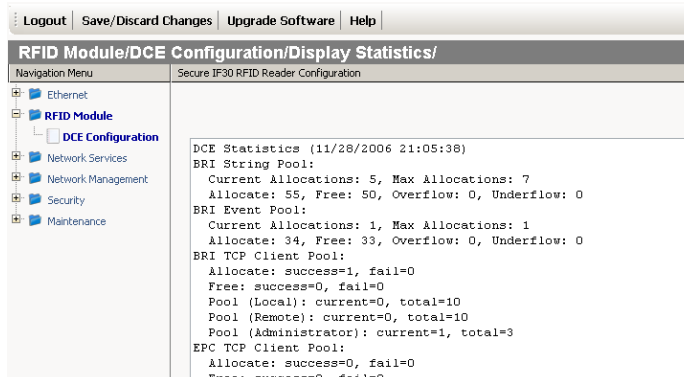

Chapter 3 — Creating and Using RFID Applications

- 3** To save the list, click **Download Statistics File** and then choose **File > Save As** in the browser menu. Follow the prompts to save the list to your desktop PC as a .txt file.



4 Managing, Upgrading, and Troubleshooting the IF30

This chapter includes information on managing the IF30 and includes these topics:

- Managing the IF30
- Using Intermec SmartSystems Foundation
- Using Wavelink Avalanche
- Enabling Simple Network Management Protocol (SNMP)
- Maintaining the IF30
- Upgrading Firmware
- Troubleshooting the IF30
- Calling Intermec Product Support

Managing the IF30

There are several methods you can use to manage the IF30. You can use:

- a web browser. For help, see “Using the Web Browser Interface” on page 14. This manual assumes that you are using this method for all procedures.
- Intermec SmartSystems Foundation. For help, see the next section.
- the Wavelink Avalanche client management system. For help, see “Using Wavelink Avalanche” on page 55.
- an SNMP management station. For help, see “Enabling Simple Network Management Protocol (SNMP)” on page 57.

Using Intermec SmartSystems Foundation

The IF30 ships with a SmartSystems Client, which means you can manage it from a central host PC using Intermec’s SmartSystems Foundation. The SmartSystems Console displays all SmartSystems-enabled devices in your network.

SmartSystems Foundation is available for free from the Intermec web site. To download SmartSystems Foundation, go to www.intermec.com/SmartSystems. For information on using the SmartSystems Console, in the Console choose **SmartSystems > Help**.

Configuring the IF30 with Intermec Settings

- In the console, right-click an IF30 and choose **Intermec Settings** from the menu. The Intermec Settings browser appears.

For help with using Intermec Settings, in the Intermec Settings browser choose **Help > Online Manual**.

Using Wavelink Avalanche

The Wavelink Avalanche client management system uses three main components to help you easily manage your wireless network.

Avalanche Component Descriptions

Component	Description
Enabler	Installed on all devices that can be managed by the Avalanche system. It communicates information about the device to the Avalanche Agent and manages software applications on the device.
Agent	Automatically detects and upgrades all devices in the Avalanche system and manages the daily processing functions.
Console	The administrative user interface that lets you configure and communicate with the Avalanche Agent. From the console, you can configure and monitor devices and build and install software packages and software collections.

Avalanche uses a hierarchical file system organized into software packages and software collections:

- Software packages are groups of files for an application that resides on the device.
- Software collections are logical groups of software packages.

For more information, see the Wavelink Avalanche documentation and online help. Or, visit the Wavelink web site at www.wavelink.com.

To configure the IF30 to use Avalanche

- 1 From the menu, click **Network Management**. The Network Management screen appears.

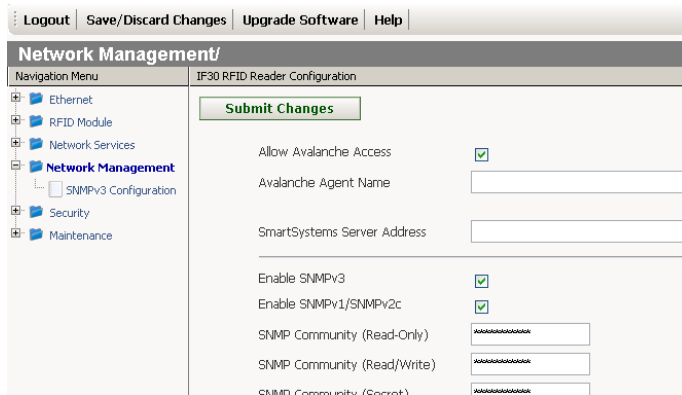

- 2 Configure Avalanche settings. For help, see the next table.
- 3 Click **Submit Changes** to save your changes. To activate your changes, from the menu bar click **Save/Discard Changes**, and then click **Save Changes and Reboot**. For help, see “Saving Configuration Changes” on page 15.

Wavelink Avalanche Parameter Descriptions

Parameter	Description
Allow Avalanche Access	Enables/disables the Avalanche client management system.
Avalanche Agent Name	Specifies the IP address or DNS name of the Avalanche console. Or, leave this field blank and the IF30 sends out a broadcast request looking for any available agent.

Enabling Simple Network Management Protocol (SNMP)

You can access and manage the IF30 from a Simple Network Management Protocol (SNMP) station. Contact a representative if you need to obtain a copy of the management information base (MIB).

Before you can use an SNMP management station, you must define the IF30 SNMP community strings.

To configure the SNMP community strings

- 1 From the menu, click **Network Management**. The Network Management screen appears.

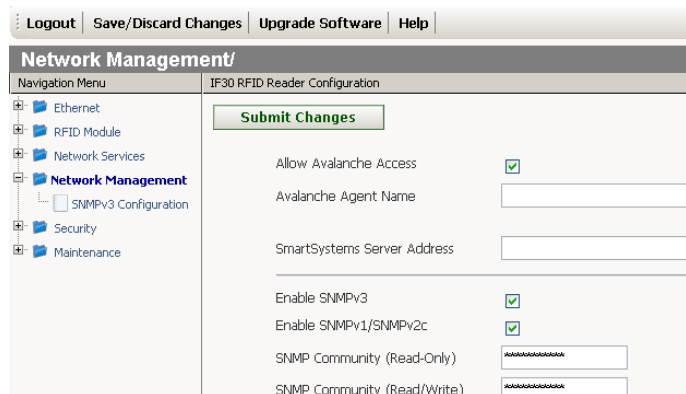

- 2 Configure the SNMP community parameters. For help, see the table on the next page.
- 3 If you enabled SNMPv3, click **Network Management > SNMPv3 Configuration**. The SNMPv3 Configuration screen appears.

If you did not enable SNMPv3, continue with Step 5.

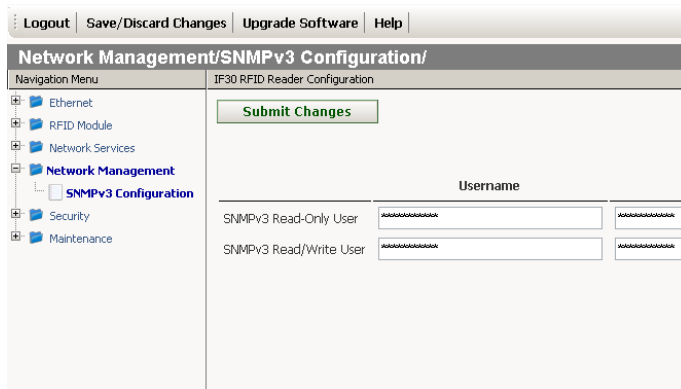

- 4 Change settings for SNMPv3. For help, see the next table.
- 5 Click **Submit Changes** to save your changes. To activate your changes, from the menu bar click **Save/Discard Changes**, and then click **Save Changes and Reboot**. For help, see “Saving Configuration Changes” on page 15.

SNMP Community Parameter Descriptions

Parameter	Description
Enable SNMPv3	Enables/disables SNMPv3.
Enables SNMPv1/ SNMPv2c	Enables/disables SNMPv1 and SNMPv2c.
SNMP Community (Read-Only)	Specifies a password that provides read-only access. This password can be from 1 to 15 characters and is case-sensitive. The default is <code>public</code> .
SNMP Community (Read/Write)	Specifies a password that provides read and write access. This password can be from 1 to 15 characters and is case-sensitive. The default is <code>CR52401</code> .
SNMP Community (Secret)	Specifies a password that provides read and write access and lets the user change the community strings. This password can be from 1 to 15 characters and is case-sensitive. The default is <code>secret</code> .
SNMPv3 Read-Only User	Specifies a password that provides read-only access. This password can be from 1 to 15 characters and is case-sensitive.

SNMP Community Parameter Descriptions (continued)

Parameter	Description
SNMPv3 Read-Write User	Specifies a password that provides read and write access. This password can be from 1 to 15 characters and is case sensitive.
Authentication Protocol	Specifies the protocol for authenticated SNMPv3 messages. This must match a supported authentication protocol on the SNMP management station.
Data Privacy Protocol	Specifies the protocol for encrypted SNMPv3 messages. This must match a supported encryption protocol on the SNMP management station.

Maintaining the IF30

The Maintenance menu lets you view IF30 parameters and characteristics, including:

- port statistics.
- a list of logged events.
- a configuration summary.

You may need this information when you call Intermecc Product Support.

Viewing Port Statistics

The Port Statistics screen shows the total number of packets and bytes the IF30 has received and transmitted since it was last booted.

To view port statistics

- From the menu, click **Maintenance > Port Statistics**. The Port Statistics screen appears.

The screenshot shows the 'Maintenance/Port Statistics/' screen. At the top, there are buttons for 'Logout', 'Save/Discard Changes', 'Upgrade Software', and 'Help'. Below this is a 'Navigation Menu' on the left and 'IF30 RFID Reader Configuration' on the right. The 'Port Statistics' option is selected in the menu. The main content area displays 'Ethernet' statistics in two tables.

	Packets	Errors	Drops	FIFO Errors	Frame Error	Mt
Rx	436929	0	0	0	0	

	Packets	Errors	Drops	FIFO Errors	Collisions	Carr
Tx	19654	0	0	0	0	

Viewing the Events Log

The Events Log screen shows the events that have been logged by the IF30. These events are cleared when the IF30 loses power or is rebooted.

To view the events log

- From the menu, click **Maintenance > Events Log**. The Events Log screen appears.

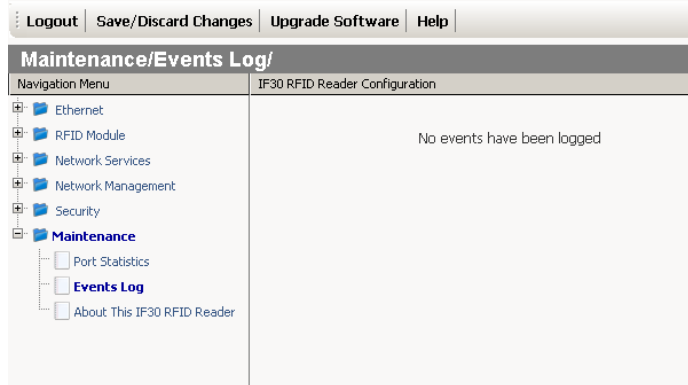

Viewing the About This IF30 RFID Reader Screen

The About This IF30 RFID Reader screen summarizes the configuration settings for the IF30 and includes a list of software versions, serial numbers, and other IF30-specific information. Any changes from the default configuration that have been made to the IF30 appear in blue.

To view the About This IF30 RFID Reader screen

- From the menu, click **Maintenance > About This IF30 RFID Reader**. The About This IF30 RFID Reader screen appears.

Copyright © 1995-2006 Intermecc Technologies Corporation reserved.

Find This IF30

The 'Find This IF30' button will cause the LEDs to blink in a u...
The two outer LEDs will be unchanged; the inner LEDs will all...
This feature is intended to help physically locate this

Boot code version	6.90
Code version	1.20
Software Release	1.00
Serial Number	07200500013
Configuration String	if30a00000000012
Total Running Processes	56
Total flash memory	16777216 Bytes
Total RAM (Userspace)	31551488 Bytes
Available RAM	13459456 Bytes
System up-time	0:00:11:35 (Days:Hours:Minutes:Seconds)
System time	Friday, January 19, 2007 16:3

RFID Module	
Firmware version	6.33

You can use the LEDs to help locate a specific IF30 in your location.

To locate the IF30

- On the About This IF30 RFID Reader screen, click **Find This IF30**. The middle three LEDs on the IF30 start flashing, while the two LEDs on the end are unchanged. The LEDs flash until you click **Finished Finding IF30**.

Viewing the IF30 Configuration Summary

The About This IF30 RFID Reader screen includes a summary that shows basic parameter settings. Parameters that have been changed from the default configuration appear in blue.

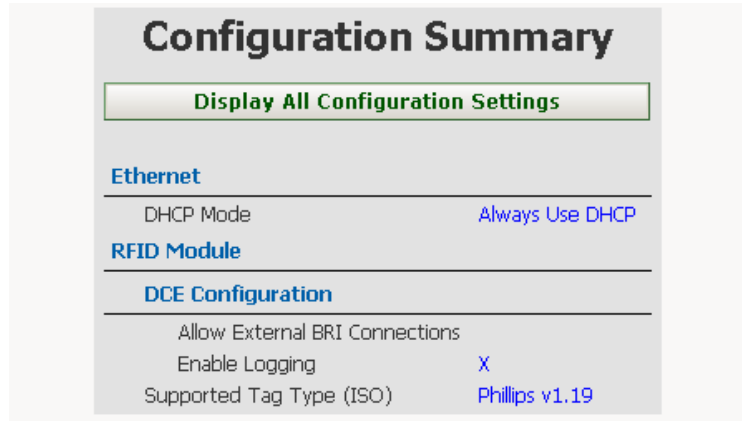

Follow the next procedure to see a complete list of settings.

To view all IF30 configuration settings

- In the About This IF30 RFID Reader Screen, scroll down and click **Display All Configuration Settings**. The screen refreshes and shows a list of complete settings.

The screenshot shows a 'Configuration Summary' screen with a button 'Display Only Differences From Defaults'. Below the button are three sections: Ethernet, IPv6 Configuration, and RFID Module. The Ethernet section lists DHCP Mode, IP Address, IP Subnet Mask, and IP Router (Gateway). The IPv6 Configuration section lists Enable IPv6 and Link Speed. The RFID Module section lists DCE Configuration with various parameters like Allow External BRI Connections, BRI TCP Port, etc.

Ethernet	
DHCP Mode	Use DHCP if IP Address is Zero
IP Address	136.179.85.105
IP Subnet Mask	255.255.255.0
IP Router (Gateway)	136.179.85.1

IPv6 Configuration	
Enable IPv6	
Link Speed	Auto Select

RFID Module	
DCE Configuration	
Allow External BRI Connections	X
BRI TCP Port	2189
BRI Heartbeat	
Trigger Management	
Allow External EPC Connections	X
EPC TCP Port	4684
Enable Logging	
Supported Tag Type (ISO)	None

To hide parameter settings that have not been changed

- Click **Display only Differences From Defaults**. The screen refreshes and shows only parameters changed from the default values.

Restoring the IF30 to the Default Configuration

- 1 From the menu, click **Save/Discard Changes**. The Save/Discard Changes screen appears.

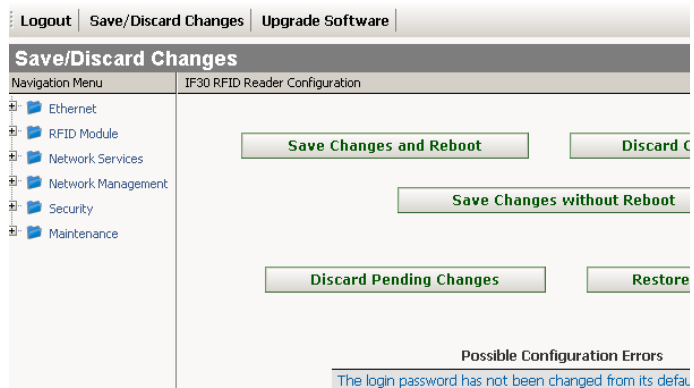

- 2 Click **Restore Factory Defaults**. A list of parameters that will be changed appears in the **Pending Changes** list.
- 3 Click **Save Changes and Reboot**. The IF30 reboots and the default configuration is restored.

Upgrading Firmware

This section explains how to import and install the IF30 and RFID firmware upgrades to the IF30.



Note: To upgrade the firmware, use only files provided by Intermec. Be sure to contact your Intermec RFID system consultant before upgrading.



Make sure the IF30 is connected to a reliable AC power source before you upgrade the firmware. Do not cycle power to the IF30 during the upgrade. If AC power is lost during the upgrade, the IF30 may require factory repair.

To upgrade the firmware

- 1 From the menu, click **Upgrade Software**. The Upgrade Software screen appears.

The screenshot shows the 'Upgrade Software' screen in the IF30 RFID Reader Configuration web interface. At the top, there are navigation tabs: 'Logout', 'Save/Discard Changes', and 'Upgrade Software'. Below the tabs is a header 'Upgrade Software' and a sub-header 'IF30 RFID Reader Configuration'. On the left is a 'Navigation Menu' with expandable items: Ethernet, RFID Module, Network Services, Network Management, Security, and Maintenance. The main content area contains a red warning: 'Warning: Do not close or navigate away from this page during up'. Below the warning is the text 'Enter or select the name of the firmware upgrade file:' followed by an input field and a 'Browse...' button. A green button labeled 'Transfer upgrade file to IF30' is positioned below the input field. At the bottom, there is explanatory text: 'Before upgrading the firmware, you must obtain an upgrade file from our website. Enter the correct file name in the input field above or click the "Browse..." button to open a file browser. When the correct file name is displayed in the input field, click the "Upgrade" button to begin the upgrade.' and 'The upgrade will take up to three minutes to complete. Once it finishes, the device will reboot before the new firmware will take effect.'

- 2 Click **Browse** to browse to the location of the upgrade file, and then double-click the filename. The name of the file appears in the **Enter or select the name of the firmware upgrade file:** entry field.
- 3 Click **Upgrade**. The file is imported to the IF30. When the file has been imported, the Save/Discard Changes screen appears. The new firmware version appears under Pending Upgrade. You may need to scroll to see this part of the screen.

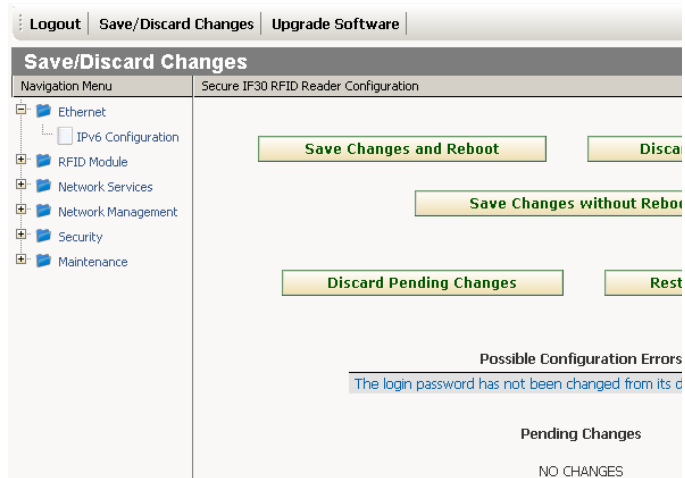

- 4 To continue the upgrade, click **Save Changes and Reboot**. The Rebooting screen appears, the IF30 reboots, and the upgrade begins. This process can take several minutes. Do not cycle power to the IF30 during the upgrade. When the upgrade process is complete, the IF30 reboots.
To cancel the upgrade, click **Discard Pending Changes**.

Troubleshooting the IF30

This section includes lists of problems and possible solutions.

Problems While Working With RFID

Many problems you may encounter when working with your RFID system can be solved by carefully checking the RFID settings and changing them accordingly. For help, see “Configuring RFID Settings” on page 42.

RFID Problems and Solutions

Problem	Solution
The IF30 is unable read RFID tags, or seems to read tags slowly or inconsistently.	<p>Check these conditions:</p> <ul style="list-style-type: none">• Your RFID antennas must be connected correctly to the IF30 and mounted in optimum locations. Make sure all antenna connections are tight and that the cables are in good condition. For help, contact your Intermec RFID system consultant.• Terminators must be installed on all unused RFID antenna ports. If you have operated the IF30 without terminators on all unused antenna ports, the RFID module may be damaged. For help, contact Intermec Product Support.• To maximize IF30 performance, make sure you have chosen the correct Tag Type for your application. For help, see “Configuring RFID Settings” on page 42.

Problems With Network Connectivity

When troubleshooting problems with network connectivity, make sure you know and understand these network-specific settings:

- TCP/IP settings
- COM port settings for serial connections

You should also make sure all physical network connectors and cables are in good working order.

Connectivity Problems and Solutions

Problem	Solution
You have assigned a static IP address to the IF30 but cannot connect to the IF30 over your network.	Make sure that DHCP is disabled and that your TCP/IP parameters are set correctly. For help, see “Configuring the IF30 (Setting the IP Address)” on page 9.
You cannot load a security certificate.	You must use a secure web browser connection to load certificates. For help, see “Using the Web Browser Interface” on page 14.
You cannot connect the IF30 using the serial port.	<ol style="list-style-type: none"> 1 Verify if you are using the correct null modem cable. 2 Verify that you are communicating through the correct serial port. 3 Verify that your PC is set to 9600, N, 8, 1, no flow control.
You cannot connect to the IF30 using a web browser.	<ol style="list-style-type: none"> 1 Verify that you are not using a crossover cable if you are connected to a hub or switch. Verify that you are using a crossover cable if connected directly to the server or PC. 2 Open a HyperTerminal session to the IF30, and verify that you did not enable web browser access in the Security screen. 3 If you access the Internet through a proxy server, be sure you have added the IP address of the IF30 to the Exceptions list.

Calling Intermec Product Support

You may need to call Intermec Product Support if you have problems operating the IF30. Before calling, be sure you can answer the following questions:

- What kind of network are you using?
- What were you doing when the error occurred?
- What error message did you see?
- Can you reproduce the problem?
- What version of the IF30 and RFID software are you using?
For help, see “Viewing the About This IF30 RFID Reader Screen” on page 62.

When you have these answers, call Intermec Product Support at 1-800-755-5505.



5 Using the IF30 GPIO Interfaces

This chapter explains how to access the IF30 general purpose input/output (GPIO) interfaces and how to connect industrial controls such as motion sensors or indicator lamps to the IF30 Fixed Reader. This chapter includes these topics:

- About the GPIO Interfaces
- Accessing the GPIO Interfaces
- Using the Input Interfaces
- Using the Output Interfaces
- Using the Power Interfaces

About the GPIO Interfaces

The IF30 has four general purpose input and output (GPIO) interfaces. You connect external controls such as motion sensors or indicator lamps to the GPIO interfaces, which can then trigger IF30 operations.

Each interface is electrically isolated from the IF30 and designed for low voltage DC loads. The IF30 can also supply 12VDC at 0.5A to external devices.

How the inputs and outputs are used depends on the RFID application software being used in the system. You need to coordinate input and output control wiring with the software developer.

Accessing the GPIO Interfaces

You can access the GPIO interfaces through the control port on the front panel of the IF30. The control port uses a standard 25-pin serial cable. For port pin assignments, see “Port Pin Assignments” on page 82.

You can also use the GPIO Terminal Block accessory to connect devices to the IF30 GPIO interfaces. The block provides access to the IF30 GPIO interfaces via standard screw terminals.

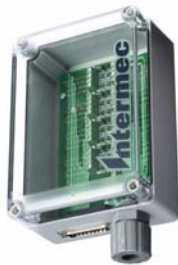

GPIO Terminal Block Accessory

For more information on the terminal block, contact your local Intermec distributor.

Using the Input Interfaces

Each of the four inputs is compatible with input signals of 10 to 48 VDC. Both of the high and low signal contacts are exposed and isolated to 1500V. Input impedance is 1.8K minimum.

GPIO Signal Input Descriptions

Signal	Description	Min.	Typical	Max.
V_{in} (High)	High input voltage	10V	24V	48V
V_{in} (Low)	Low input voltage	-1V	0V	1V

In a typical application, the IF30 senses input from an external control like a switch and then starts a tag read operation.

There are three basic ways to connect input controls to the IF30 input interfaces:

- Supply the input interface with power from the IF30.
- Isolate the IF30 from the input power source.
- Use an open collector solid state drive from a remote device to control the inputs.

IF30 Powered Input

This is the simplest way to connect a control to an IF30 input interface. If the external control device is a switch, you can connect one side of the switch to an IF30 +Input pin, and the other side of the switch to one of the +12 VDC sources, then ground the corresponding -Input pin.

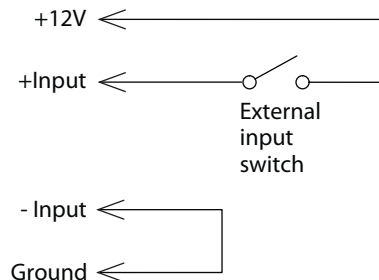

IF30 Powered Input

Isolated Input Interface

This method is used to minimize noise induced by distance or grounding. The isolated input avoids induced noise by referencing a remote input to chassis return of the IF30. The illustration below shows how to wire in this method.

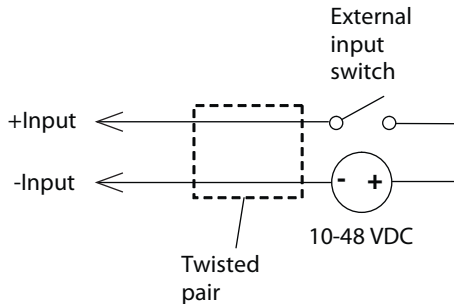

Isolated Input Interface

Open Collector Interface

The input can be connected to an open collector interface of an external device. This implies that the grounds are tied together for two systems. The common ground can be a source of noise, so you should follow good grounding practices for both the IF30 and the input device.

In this situation, the IF30 provides power to the pull-up resistor for the open collector. Connect the +Input pin to the +12 VDC source as shown in the next illustration.

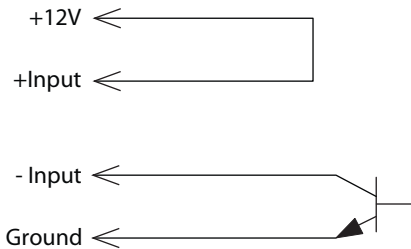

Open Collector Interface

Using the Output Interfaces

Each IF30 output interface is optically isolated, polarized, and rated for 5 to 48 VDC at 0.25A. All IF30 outputs include internal thermal fuses that trip if the load exceeds 0.25A, and the fuses are self-recovering once the excessive load is removed. The high and low contacts are exposed and isolated from the ground. Transient suppression limits output voltage spikes to 65 VDC.

GPIO Output Specifications

Signal	Description	Min.	Typical	Max.
Leakage current (High)	Switch output, high leakage current	0 mA	1 mA	10 mA
V_{sat} (Low)	Switch output on, saturation voltage with .25A load	0V	1V	1.5V

Since the outputs are optically isolated, each of the outputs can be configured to switch the high or low side of the load. You can power the load directly from the IF30 or from an external power supply.

In a typical application, the outputs control indicator lamps that signal good reads or errors. These are the basic methods for connecting external devices to the GPIO outputs:

- Switching the high side, with the load powered by the IF30.
- Switching the low side, with the load powered by the IF30.
- Switching the high side, with the load powered externally.
- Driving a DC relay that controls an AC load.

Switching the High Side Using IF30 Power

In this example, an external indicator lamp with a 0.25A maximum current is connected to the -Output and Ground pins, and the corresponding +Output pin is connected to the +12 VDC source.

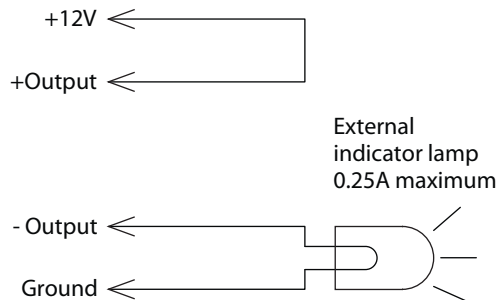

Switching the High Side

Switching the Low Side Using IF30 Power

For low side switching applications, the lamp is routed to all the lamps in common and the low side of the load is routed to the switch.

In this method, connect the external indicator lamp to the +Output and +12 VDC pins, and short the corresponding -Output pin to ground as shown.

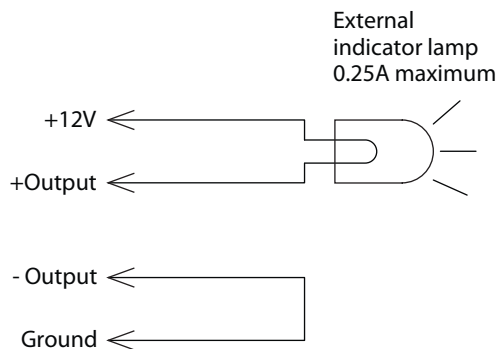

Switching the Low Side

Switching the High Side Using External Power

To use external power (5 to 48 VDC) to switch the high side, connect the Ground pin to the ground system of the external power supply, and connect the positive side of the external supply to the +Output pin. The external indicator lamp is connected to the corresponding -Output and Ground pins as shown below.

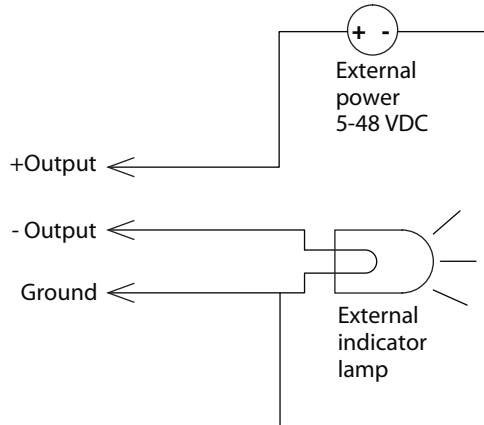

Switching the High Side With External Power

Driving a DC Relay to Control an AC Load

While the IF30 outputs are designed to switch DC loads, they can drive relays that control AC loads. The illustration on the next page shows how to connect such a system to an IF30 output.

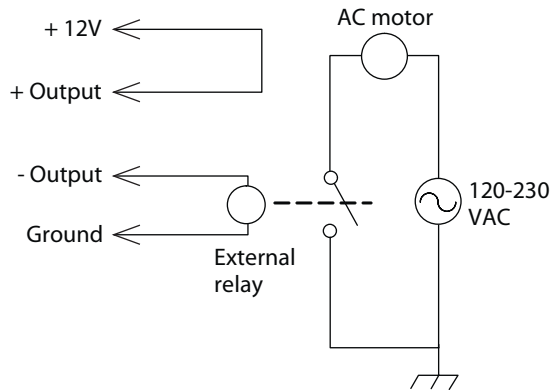

Driving a DC Relay: The external relay provides dry contacts for controlling the AC motor.



Note: In many installations, the relay and AC wiring must be placed in an enclosure that meets local fire code regulations.

Using the Power Interface

The IF30 GPIO interface provides 12 VDC at 0.5A for powering external inputs and loads, eliminating the need for an external DC supply and simplifying the system installation.

The GPIO interface power has an internal thermal fuse that trips if the load exceeds 0.5A. The fuse is self-recovering once excessive load is removed.

The total load on the GPIO interface power must stay within the 0.5A limit. When you design a system that uses the GPIO interface power, be sure to complete a power budget assessment to ensure that the supply is adequate for the system.

If your system needs more than +12 VDC at 0.5A, you can connect to an external power supply to the +12V and Ground pins. The external supply powers the external loads, and that power will be available at all +12V pins on the control port.

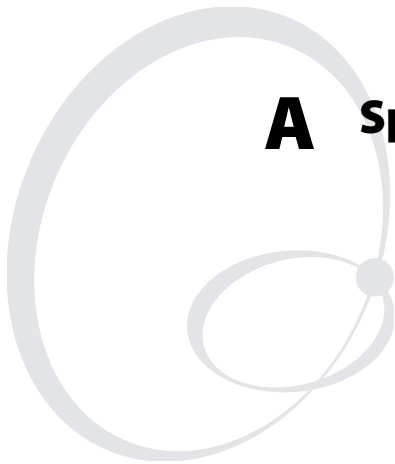

A Specifications

This appendix includes physical and electrical specifications for the IF30 and information about the port pin assignments.

IF30 Specifications

Height	9.5 cm (3.8 in)
Length	35.5 cm (14.0 in)
Width	23.6 cm (9.3 in)
Weight	2.63 kg (5.8 lb)
AC electrical rating	~ 100 to 240V, 1.0 to 0.5A, 50 to 60 Hz
Operating temperature	-25°C to +70°C (-13°F to +158°F)
Storage temperature	-40°C to +70°C (-22°F to +158°F)
Humidity (non-condensing)	10 to 90%
Ethernet interfaces	10BaseT/100BaseTx (twisted-pair)
Ethernet compatibility	Ethernet frame types and Ethernet addressing
Ethernet data rate	10 Mbps/100 Mbps
Serial port maximum data rate	115,200 bps
SNMP agent	RFC 1213 (MIB-2), RFC 1398 (dot3)
Linux version	2.6.11.5

RFID Specifications

Protocols Supported	EPCglobal Class 1 Gen 2 ISO 18000-6B Generation 1 ISO 18000-6B Generation 2 Phillips v1.19
Frequency Range	865-868 MHz, 869 MHz, or 915 MHz
Usable channels	1
Output power	
865-867 MHz, 915 MHz	Minimum: 28.5 dBm Typical: 29.5 dBm Maximum: 30.0 dBm
869 MHz	Minimum: 25.5 dBm Typical: 26.5 dBm Maximum: 27.0 dBm
Occupied frequency bandwidth	<250 KHz
Tag data rate	32 kbps/160 kbps
Dispatch rates	
Tag ID rate	70 tags per second
Tag data exchange rate	Reads a tag containing 8 bytes of data within 12 ms. Performs a verified write to a tag at an average rate of 31 mS per byte per tag.
Write range	Up to 70% of the read distance under similar conditions
Transmitter type	90% amplitude modulation index
Frequency stability	<±100 ppm from -25°C to +55°C (-13°F to 131°F)
Number of antennas	Up to 4, electronically switched
Antenna port isolation	22 dB
Antenna connectors	865-867 MHz: SMA 915 MHz: Reverse SMA

Port Pin Assignments

Control Port

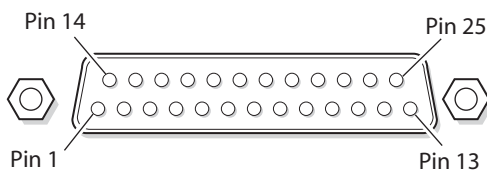

Control Port Pin Assignments

Pin	Description	Active Polarity
1	-Input 1	Low-RTN
2	-Input 2	Low-RTN
3	-Input 3	Low-RTN
4	-Input 4	Low-RTN
5	Ground	
6	Ground	
7	+Output 1	High (10-48V)
8	Ground	
9	+Output 2	High (10-48V)
10	Ground	
11	+Output 3	High (10-48V)
12	Ground	
13	+Output 4	High (10-48V)
14	+Input 1	High (10-48V)
15	+Input 2	High (10-48V)
16	+Input 3	High (10-48V)
17	+Input 4	High (10-48V)
18	12VDC	
19	-Output 1	Low-RTN
20	12VDC	
21	-Output 2	Low-RTN
22	12VDC	
23	-Output 3	Low-RTN
24	12VDC	
25	-Output 4	Low-RTN

Serial Port

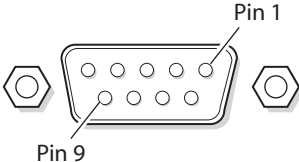

Serial Port Pin Assignments

Pin	Description	Active Polarity
1	NC	
2	Receive data (RXD)	High
3	Transmit data (TXD)	High
4	NC	
5	Signal ground	
6	NC	
7	NC	
8	NC	
9	NC	

Ethernet Port



Ethernet Port Pin Assignments

Pin	Description	Pin	Description
1	LAN_RX+	5	VDC_A
2	LAN_RX-	6	LAN_TX-
3	LAN_TX+	7	VDC_B
4	VDC_A	8	VDC_B



Note: The IF30 does not support power over Ethernet (POE).

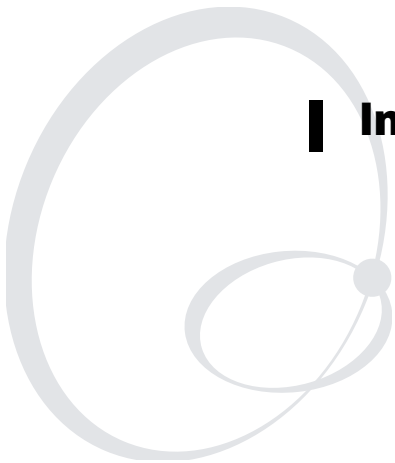

| Index

Index

A

- About This IF30 RFID Reader screen, 62
- AC power port
 - described, 5
 - location, 4
- access via menus, controlling, 31
- Allow External EPC Connection
 - setting, 49
- Allow Service Password check box, 36
- Always Use DHCP setting, 26
- antenna firing sequence, for RFID,
 - described, 48
- ANTTRIES equivalent, 46
- applications
 - configuring data collection engine, 48
 - how to develop, 42
- Avalanche, *See* Wavelink Avalanche

B

- Basic Reader Interface
 - attribute equivalents for RFID module
 - settings, 44
 - blue LED, described, 7
 - Heartbeat setting, 49
 - TCP Port setting, for DCE, 49
- blue LED, described, 7
- bracket, mounting, described, 18
- BRI Heartbeat setting, 49
- BRI TCP Port setting, for DCE, 49
- Browser Access setting, described, 32
- BRI. *See* Basic Reader Interface

C

- cable access door, removing, 4
- cautions, described, vii
- Certificate Details screen, illustrated, 37
- configuring the IF30
 - active configuration file, described, 16
 - connecting via Ethernet, 11
 - connecting with communications
 - program, 10
 - current configuration file, described, 16
 - data collection engine, 48
 - default configuration file, described, 16
 - default configuration, restoring, 65
 - DHCP settings, 26
 - DNS settings, 28

- configuring the IF30 (*continued*)
 - Ethernet link speed, 24
 - Ethernet settings, 24
 - firmware, upgrading, 66
 - Intermec Settings, using, 54
 - IP address, 9
 - network services, 28
 - network settings, 24
 - password server, 34
 - saving changes, 17
 - security, 30
 - setting IP address, described, 9
 - SNTP client settings, 30
 - SYSLOG destination, 28
 - username and password, setting, 33
 - using web browser interface, 14
 - viewing summary, 62
- control port
 - location, 4
 - pin assignments, 82

D

- data collection engine, 49
 - Allow External BRI Connection, 49
 - BRI TCP Port, 49
 - configuring, 48
 - Enable Logging, 49
 - EPC TCP Port, 49
 - log, enable and viewing, 50
 - logfile command event descriptions, 51
 - settings, described, 49
 - statistics, viewing, 51
 - trigger, managing, 49
 - using with Intermec Ready-To-Work
 - indicator, 7
- Data Privacy Protocol setting, for
 - SNMPv3, 58, 59
- date and time
 - setting with web browser interface, 20
 - SNTP client settings, 30
- DCE Configuration screen, illustrated, 48
- default configuration, restoring, 65
- default login, changing, 35
- defaults, restoring, 65
- DHCP Mode setting, 26
- DHCP settings, configuring, 26
- Disable DHCP setting, 26

- Display Log screen, for DCE,
 - illustrated, [50](#)
- DNS settings, configuring, [28](#)
- E**
- electrical specifications, [80](#)
- Enable Antenna Port check box, [48](#)
- Enable Logging check box, for DCE, [49](#)
- Enabling Autoconfiguration, for IPv6, [27](#)
- EPC TCP Port setting, [49](#)
- EPCglobal Class 1 Gen 2
 - certification, [2](#)
 - tags, choosing in RFID Module Settings, [44](#)
- Ethernet, [26](#)
 - IF30 in wired network, illustrated, [9](#)
 - port
 - described, [5](#)
 - pin assignments, [83](#)
 - settings, configuring with web browser interface, [24](#)
 - troubleshooting problems, [69](#)
- Ethernet port
 - location, [4](#)
- Events Log screen, illustrated, [61](#)
- events log, viewing in Maintenance menu, [61](#)
- external controls, using with IF30, [72](#)
- F**
- Field Separator setting, [45](#)
- Field Strength setting, [47](#)
- fields, in tags, separating, [45](#)
- FIELDSEP equivalent, [45](#)
- FIELDSTRENGTH equivalent, [48](#)
- firmware upgrades, [66](#)
- front panel ports
 - accessing, [4](#)
 - described, [5](#)
- G**
- general purpose input/output
 - interfaces, [72](#)
 - accessing, [72](#)
 - described, [72](#)
 - inputs, using, [73](#)
 - isolated input, [74](#)
 - open collector input, [74](#)
 - general purpose input/output interfaces
 - (*continued*)
 - output, switching the high side using external power, [76](#)
 - output, switching the low side, [76](#)
 - power, using, [78](#)
 - powered input, [73](#)
 - relay, driving to control AC load, [78](#)
 - switching the high side using external power, [77](#)
- GPIO. *See* general purpose input/output interfaces
- H**
- HyperTerminal, using to configure IF30, [10](#)
- I**
- ID Report check box, [45](#)
- ID Tries setting, [46](#)
- IDTRIES equivalent, [46](#)
- IF30
 - configuration summary, viewing, [63](#)
 - connecting to network, [19](#)
 - connecting with communications program, [10](#)
 - default configuration, restoring, [65](#)
 - described, [2](#)
 - DHCP state, describe, [9](#)
 - dimensions, [80](#)
 - Ethernet network, described and illustrated, [9](#)
 - firmware, upgrading, [66](#)
 - installing, [18](#)
 - IP address, setting, [9](#)
 - learning about, [4](#)
 - locating with LEDs, [62](#)
 - maintaining, [60](#)
 - managing, [54](#)
 - mounting location, choosing, [18](#)
 - overview, [2](#)
 - related documents, list of, [ix](#)
 - RFID settings, configuring, [42](#)
 - SNMP, managing with, [57](#)
 - specifications, [80](#)
 - troubleshooting, [68](#)
 - unpacking, [3](#)

Index

- IF30 (*continued*)
 - using securely, [21](#)
- Init Tries setting, [46](#)
- Initial Queue, [47](#)
- initialize tags setting, [46](#)
- INITIALQ equivalent, [47](#)
- INITTRIES equivalent, [46](#)
- input interface
 - isolated, [74](#)
 - open collector, [74](#)
 - powered, [73](#)
 - signal descriptions, [73](#)
- installing
 - IF30, [18](#)
 - RFID antennas, [19](#)
- Intermec
 - Global Sales and Service, [vii](#)
 - Knowledge Central, [vii](#)
 - manuals, how to download from web, [ix](#)
 - Product Support, what to know when calling, [70](#)
 - Settings, application, [54](#)
 - SmartSystems Console, [54](#)
- Internet Protocol version 6
 - enabling in communications program, [12](#)
 - enabling in web browser interface, [27](#)
- IP address
 - saving changes, [15](#)
 - setting, [9](#)
 - with communications program, [10](#)
 - with web browser interface, [24](#)
- IPv6. *See* Internet Protocol version 6
- L**
- LEDs
 - described, [6](#)
 - Intermec Ready-to-Work Indicator, [6](#)
 - location, [6](#)
 - power, [6](#)
 - wired LAN, [6](#)
- location, choosing for IF30, [18](#)
- Lock Tries setting, [47](#)
- LOCKTRIES equivalent, [47](#)
- login screen, [14](#)
- login, changing default, [35](#)
- M**
- maintaining the IF30, [60](#)
- Maintenance menu
 - About this IF30 RFID Reader screen, [62](#)
 - configuration summary, [63](#)
 - events log, viewing, [61](#)
 - port statistics, viewing, [60](#)
 - using LEDs to locate the IF30, [62](#)
- managing the IF30
 - defaults, restoring, [65](#)
 - firmware, upgrading, [66](#)
 - methods, [54](#)
 - SmartSystems Foundation, [54](#)
 - SNMP, [57](#)
 - using securely, [21](#)
- manuals, Intermec, how to download from web, [ix](#)
- motion sensors
 - using with the IF30, [72](#)
- mounting location, choosing, [18](#)
- N**
- network, [19](#)
 - connecting IF30 to, [19](#)
 - DNS settings, configuring, [28](#)
 - Ethernet connection, in
 - communications program, [11](#)
 - IF30 illustrated in, [9](#)
 - SNTP client settings, configuring, [30](#)
 - SYSLOG destination, configuring, [28](#)
- No Tag Report check box, [45](#)
- NOTAGRPT equivalent, [45](#)
- NOTAGS message, enabling or disabling, [45](#)
- notes, described, [vii](#)
- O**
- output interface
 - driving external DC relay, [78](#)
 - high side switching, [76](#)
 - high side switching with eternal power, [77](#)
 - low side switching, [76](#)
 - output interfaces, [75](#)
 - signal descriptions, [73](#)
- overview of the IF30, [2](#)

P

- Password
 - user login, 36
- password settings, described, 36
- Passwords screen
 - illustrated, 34
- patent information, x
- pin assignments, for ports, 82
- pinouts, 82
- port pin assignments
 - control, 82
 - Ethernet, 83
 - serial, 83
- ports
 - AC power, 5
 - control, 5
 - Ethernet, 5
 - front panel, accessing, 4
 - front panel, described, 5
 - pin assignments, 82
 - rear panel, described, 8
 - RFID antenna, 8
 - serial, 5
- power interface, 78
- power port, described, 5
- problems with IF30, solving, 68
- Product Support, calling Intermec, 70
- proxy server, using to access Internet, 14

R

- RADIUS authentication server,
 - described, 33
- RDTRIES equivalent, 46
- Read Only Password setting, 36
- Read Tries setting, 46
- reader module, settings, 42
- Ready-to-Work indicator, described, 7
- rear panel ports, described and illustrated, 8
- Reject Expired Certificates check box, 32, 39
- RFID
 - antenna firing sequence, described, 48
 - antenna port locations, 8
 - applications, how to develop, 42
 - IF30 settings, described, 44
 - module, configuring, 42

RFID (*continued*)

- RFID Module screen, illustrated, 43
- specifications, 81
- troubleshooting problems, 68

S

- safety information, vii
- Saving Configuration Changes, 15
- securely using the IF30, 21
- security
 - certificates described, 37
 - configuring, 30
 - controlling menu access, 31
 - default login, changing, 35
 - password server, using with IF30, 34
 - supported methods, 30
- Select Tries setting, 47
- SELTRIES equivalent, 47
- serial port
 - location, 4
 - pin assignments, 83
- service password, described, 36
- SESSION equivalent, 47
- Session settings, 47
- Set Clock screen, 20
- Simple Network Time Protocol (SNTP)
 - client settings, configuring, 30
- SmartSystems Foundation, Intermec, using to manage IF30, 54
- SNMP
 - Community settings, described, 58
 - parameters, described, 58
 - using to manage IF30, 57
- SNMPv3
 - Authentication Protocol, 58, 59
 - Data Privacy Protocol, 59
 - enabling, 57
 - settings, described, 58
- specifications
 - electrical and physical, 80
 - RFID, 81
- summary of configuration settings in Maintenance menu, 63
- summary of settings, viewing, 63
- support, calling Intermec, 70
- SYSLOG destination
 - configuring, 28

- SYSLOG (*continued*)
 defined, 29
 SYSLOG server, 29
- T**
- Tag Type setting, 44
 tags, RFID
 choosing type, 44
 ID reporting, enabling or disabling, 45
 TAGTYPE equivalent, 44
 TCP/IP screen, illustrated, 25
 TCP/IP settings, configuring, 24
 terminators, location, 8
 time and date
 setting with web browser interface, 20
 SNTP client settings, 30
 Timeout Configuration mode,
 enabling, 45
 TIMEOUTMODE equivalent, 45
 trigger, managing with data collection
 engine, 49
 TRIGGERREADY command, from
 DCE, 49
 troubleshooting the IF30, 68
 connectivity problems, 69
 default configuration, restoring, 65
 Intermec Product Support, calling, 70
 port statistics, viewing, 60
 RFID problems, 68
- U**
- Unpacking the IF30, 2
- Unselect Tries setting, 47
 UNSELTRIES equivalent, 47
 upgrade files, where to find, 66
 Upgrade Software screen, illustrated, 66
 upgrading firmware, 66
 Use DHCP if IP Address is Zero
 setting, 26
 Use RADIUS for Login Authorization
 check box, 36
 User Name setting, for passwords, 36
 Using the IF30 Securely, 21
- W**
- warnings, described, vii
 Wavelink Avalanche
 parameters, described, 56
 using to manage IF30, 56
 web browser interface, 14
 data collection engine, changing
 settings, 48
 date and time, setting, 20
 defaults, restoring, 65
 enabling or disabling, 31
 Maintenance menu, 60
 RFID module, changing settings, 42
 secure, 14, 15
 SNMP, enabling, 57
 upgrading firmware, 66
 Wavelink Avalanche, enabling, 55
 Write Tries setting, 46
 WRTRIES equivalent, 46

