

ioLogik E2210 User's Manual

Sixth Edition, June 2008

www.moxa.com/product

MOXA®

© 2008 Moxa Inc., all rights reserved.
Reproduction without permission is prohibited.

ioLogik E2210 User's Manual

The software described in this manual is furnished under a license agreement, and may be used only in accordance with the terms of that agreement.

Copyright Notice

Copyright © 2008 Moxa Inc.
All rights reserved.
Reproduction without permission is prohibited.

Trademarks

MOXA is a registered trademark of Moxa Inc.
All other trademarks or registered marks in this manual belong to their respective manufacturers.

Disclaimer

Information in this document is subject to change without notice, and does not represent a commitment on the part of Moxa.

Moxa provides this document “as is,” without warranty of any kind, either expressed or implied, including, but not limited to, its particular purpose. Moxa reserves the right to make improvements, and/or changes to this manual, or to the products, and/or the programs described in this manual, at any time.

Information provided in this manual is intended to be accurate, and reliable. However, Moxa assumes no responsibility for its use, or for any infringements on the rights of third parties that may result from its use.

This manual might include unintentional technical or typographical errors. Changes are made periodically to the information herein to correct such errors, and these changes are incorporated into new editions of the manual.

Technical Support Contact Information

www.moxa.com/support

Moxa Americas:

Toll-free: 1-888-669-2872
Tel: +1-714-528-6777
Fax: +1-714-528-6778

Moxa China (Shanghai office):

Toll-free: 800-820-5036
Tel: +86-21-5258-9955
Fax: +86-10-6872-3958

Moxa Europe:

Tel: +49-89-3 70 03 99-0
Fax: +49-89-3 70 03 99-99

Moxa Asia-Pacific:

Tel: +886-2-8919-1230
Fax: +886-2-8919-1231

Table of Contents

Chapter 1.	Introduction	1-1
	Overview	1-2
	Traditional Remote I/O.....	1-2
	Active Ethernet I/O.....	1-2
	Click&Go	1-3
	Optional Liquid Crystal Display Module (LCM)	1-3
	Product Features	1-3
	Packing List.....	1-3
	Product Specifications.....	1-4
	Physical Dimensions	1-5
	Without LCD Module.....	1-5
	With LCD Module.....	1-6
	Hardware Reference	1-7
	Panel Guide	1-7
	LED Indicators	1-7
Chapter 2.	Initial Setup.....	2-1
	Hardware Installation	2-2
	Connecting the Power.....	2-2
	Grounding the ioLogik E2210.....	2-2
	Connecting to the Network.....	2-2
	Setting the RS-485 Baudrate	2-2
	Adding More I/O Channels	2-3
	Software Installation.....	2-3
Chapter 3.	Using ioAdmin	3-1
	Introduction to ioAdmin	3-2
	Features of ioAdmin	3-2
	ioAdmin Main Screen.....	3-4
	Main Screen Overview	3-4
	Wiring Guide	3-5
	Main Items.....	3-5
	File.....	3-5
	System	3-6
	Sort	3-7
	Help	3-7
	Quick Links	3-7
	Main Window	3-8
	I/O Configuration Tab (General)	3-8
	Server Info Tab.....	3-8
	Server Settings Tab (General)	3-9
	Message Monitor Tab.....	3-9
	ioAdmin Administrator Functions	3-10
	I/O Configuration Tab (Administrator)	3-10
	Server Settings Tab (Administrator).....	3-13
	Network Tab.....	3-13
	Firmware Update Tab.....	3-14
	Watchdog Tab.....	3-15
	Click&Go Logic Tab	3-16

	Server Context Menu.....	3-16
	Using TFTP to Import/Export Configuration	3-18
	Using ioEventLog.....	3-19
	Installing ioEventLog	3-19
	Basic Functions.....	3-19
	Configuration.....	3-20
	Checking Connected Devices	3-21
	Opening Log Files	3-21
	Clearing the Log	3-21
Chapter 4.	Using the Web Console	4-1
	Introduction to the Web Console	4-2
	Basic Settings	4-2
	Network Settings	4-3
	General Settings.....	4-3
	Ethernet Configuration	4-4
	RS-485 Settings	4-4
	I/O Settings.....	4-5
	DI Channels	4-5
	DO Channels	4-6
	System Management	4-6
	Accessible IP Settings.....	4-6
	SNMP Agent	4-7
	Network Connection.....	4-8
	Firmware Update	4-8
	Import System Config	4-8
	Export System Config	4-9
	LCM	4-9
	Change Password.....	4-9
	Load Factory Default.....	4-10
	Save/Restart.....	4-10
Chapter 5.	Click&Go Logic.....	5-1
	Overview	5-2
	Features	5-2
	Click&Go Logic Basics.....	5-3
	Working with Rules.....	5-3
	Defining Logic Rules	5-4
	IF Conditions	5-4
	More Info on Repeat Interval vs. Edge Detection	5-5
	THEN Actions	5-7
	Defining Peer-to-Peer I/O Rules.....	5-10
	Configuring Input for Peer-to-Peer I/O.....	5-12
	Configuring Output for Peer-to-Peer I/O.....	5-12
	Working with Click&Go Rulesets	5-13
	Activating the Ruleset.....	5-13
	Ruleset Management Bar.....	5-13
	Ruleset Import/Export	5-14
	Application Examples	5-14
	Local I/O Control.....	5-14
	Active I/O Messages.....	5-14
	Peer-to-Peer I/O.....	5-15

	MXIO DLL for Active I/O Messages.....	5-17
Appendix A.	Liquid Crystal Display Module (LCM).....	A-1
Appendix B.	Modbus/TCP Address Mappings	B-1
	0xxxx Read/Write Coils (Functions 1, 5, 15)	B-1
	1xxxx Read Only Coils (Function 2).....	B-4
	3xxxx Read Only Registers (Function 4)	B-4
	4xxxx Read/Write Registers (Functions 3, 6, 16).....	B-5
	Function 8.....	B-12
Appendix C.	Used Network Port Numbers.....	C-2
Appendix D.	SNMP MIB II	D-1
Appendix E.	Factory Default Settings	E-2
Appendix F.	Pinouts and Cable Wiring.....	F-1
	Ethernet Port Pinouts	F-1
	Serial Port Pinouts	F-1
	Digital Input Wiring	F-1
	Structure	F-1
	Dry Contact	F-2
	Wet Contact	F-2
	Example.....	F-2
	Digital Output.....	F-3
	Structure	F-3
	Output Channel.....	F-3
	Pin Assignment of Terminal Blocks	F-4

The ioLogik E2210 is a stand-alone Active Ethernet I/O server that can connect sensors and on/off switches for automation applications over Ethernet and IP-based networks.

The following topics are covered in this chapter:

- ❑ **Overview**
 - Traditional Remote I/O
 - Active Ethernet I/O
 - Click&Go
 - Optional Liquid Crystal Display Module (LCM)
- ❑ **Product Features**
- ❑ **Packing List**
- ❑ **Product Specifications**
- ❑ **Physical Dimensions**
 - Without LCD Module
 - With LCD Module
- ❑ **Hardware Reference**
 - Panel Guide
 - LED Indicators

Overview



(shown with and without optional LCM)

The ioLogik E2210 is part of the E2000 line of ioLogik Active Ethernet I/O servers, which are designed for intelligent, pro-active status reporting of attached sensors, transmitters, transducers, and valves over a network. It includes 2 MB of Flash ROM, 8 MB of SDRAM, and supports an optional hot-pluggable Liquid Crystal Display Module (LCM) to view and configure device settings.

Traditional Remote I/O

Ethernet remote I/O solutions have been on the market for a long time. Traditional solutions are “passive,” in the sense that I/O servers wait passively to be polled by a host computer. The response time in this type of setup, however, tends to be on the order of seconds. The “passive” remote I/O structure is simply inadequate for data acquisition and control systems that require an efficient, real-time I/O solution with a response time on the order of hundredths of seconds.

Active Ethernet I/O

Moxa's **Active Ethernet I/O** line was developed specifically to address the limitations of the traditional passive approach. Rather than having the host computer poll the I/O device server over the network for the status of each I/O device, the **Active Ethernet I/O server** intelligently sends the host computer status information only under specified conditions. This is a **report by exception** approach, which greatly reduces the load on CPU and network resources. Network packets are far fewer in number and far smaller in size, since I/O information is only sent when necessary, and only information from the specified I/O device is sent. Based on field tests of an ioLogik E2000 series server used in an RFID system, 50 ms is the typical response time over a 100 Mbps Ethernet network. Moxa's active I/O messaging system uses TCP or UDP for I/O messaging and supports sending messages to up to ten host computers simultaneously.

In addition to providing intelligent status reporting, Active Ethernet I/O servers are backwards compatible, with all of the functions and capabilities of traditional passive remote I/O servers.

Click&Go

Moxa developed the Click&Go logic control interface for easy configuration and deployment of Active Ethernet I/O. Click&Go's intuitive, graphical interface lets administrators use simple IF/THEN statements as rules to determine how the Active Ethernet I/O server responds to different I/O conditions. For example, the Active Ethernet I/O server could be programmed to turn on an attached switch as well as send an e-mail or SNMP trap when an attached event counter reaches a certain value. Click&Go makes it easy to define a set of these rules, which will become the basis for your Active Ethernet I/O system.

Optional Liquid Crystal Display Module (LCM)

As a Moxa Easy View product, the ioLogik E2210 supports an optional hot-pluggable Liquid Crystal Display Module (LCM) for field management and configuration. The LCM can display network and I/O settings such as digital input mode and value. The ioLogik E2210's IP address and netmask may also be configured using the LCM, and one LCM can be used to maintain and configure all your Easy View devices.

Product Features

- Click&Go logic builder for easy configuration of your Active Ethernet I/O system
- High-speed active I/O messaging
- 12-channels of 24 VDC digital input (DI) with DI/Event Counter mode and software selectable filtering time
- 8-channels of 24 VDC digital output (DO) with Pulse Output mode and software selectable pulse width
- 10/100 Mbps Ethernet with Modbus/TCP protocol connecting up 10 hosts
- Bundled Windows utility and quick programming library for VB, VC++, BCB
- Supports RS-485 modules for expandable I/O
- Supports SCADA software such as Wonderware InTouch and GE Intellution iFix32
- SNMP for system management and I/O status
- Remote management over the network including firmware updates
- Supports use of TFTP server to import configuration
- Configurable DO power-on and safe status settings
- Optional hot-pluggable LCM for status display and configuration

Packing List

The ioLogik E2210 is shipped with the following items:

Standard Accessories

- ioLogik E2210 Active Ethernet I/O Server
- Document and Software CD

Optional Accessories

- LDP1602 ioLogik Liquid Crystal Display Module (LCM)

NOTE: Notify your sales representative if any of the above items are missing or damaged.

Product Specifications

LAN	
Ethernet	10/100 Mbps, RJ45
Protection	1.5 KV magnetic isolation
Protocols	Modbus/TCP, TCP/IP, UDP, DHCP, Bootp, SNMP(MIB for I/O and Network), HTTP
Serial	
Interface	RS-485 (2-wire): Data+, Data-, GND
Serial Line Protection	15 KV ESD for all signals
Serial Communication parameters	
Parity	None
Data Bits	8
Stop Bits	1
Flow Control	None
Speed	1200 to 115200 bps
Protocol	Modbus/RTU
Built-in RTC	Yes
Digital Input	
Inputs	12, source type
I/O Mode	DI or Event Counter (input frequency: 900 Hz)
Dry Contact	Logic 0: short to GND, Logic 1: open
Wet Contact	Logic 0: 0 to 3 VDC, Logic 1: 10 to 30 VDC (DI COM to DI)
Common Type	12 points / 1 COM
Isolation	2000 VRMS / 3000 VDC
Digital Output	
Outputs	8, sink type
On-state Voltage	24 VDC nominal
Output Current Rating:	Max. 200 mA per channel
Optical Isolation	2000 VRMS / 3000 VDC
Protection	Over temperature shutdown: 170°C Over current limit: 750 mA/channel (typical)
Power Requirement	
Power Input	24 VDC nominal, 12 to 48 VDC
Power Consumption	282 mA @ 24 VDC (typical)
Field Power	24 VDC nominal, up to 48 VDC
Mechanical Specifications	
Wiring	I/O cable max. 14 AWG
Environmental	
Operating Temperature	-10 to 60°C (14 to 140°F), 5 to 95%RH
Storage Temperature	-40 to 85°C (-4 to 185°F), 5 to 95%RH
Shock	IEC60068-2-27
Freefall	IEC60068-2-32
Vibration	IEC60068-2-6
Agency Approvals	
EMC	FCC Part 15, CISPR (EN55022) Class A CE: IEC 61000-4-2 (ESD), Level 2/3 IEC 61000-4-3 (RS), Level 2 IEC 61000-4-4 (EFT), Level 2

IEC 61000-4-5 (Surge), Level 3
IEC 61000-4-6 (CS), Level 2
IEC 61000-4-8 (PM), Level 1
IEC 61000-4-11 (DIP)
IEC 61000-6-2
IEC 61000-6-4 (EMC)
UL 508, EN61000-6-2, EN61000-6-4
2 years

Safety
Warranty

Physical Dimensions

Without LCD Module

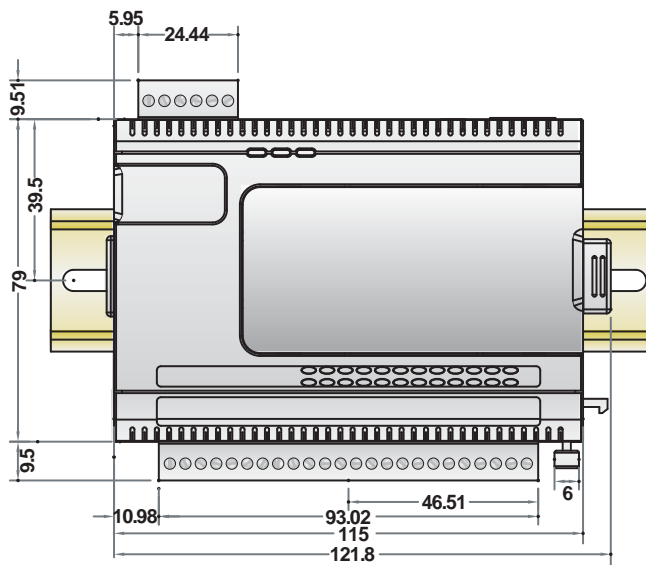
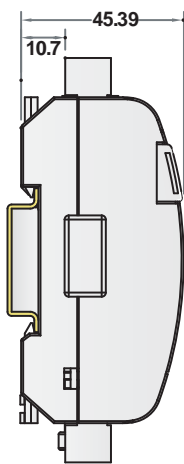

Unit=mm

With LCD Module

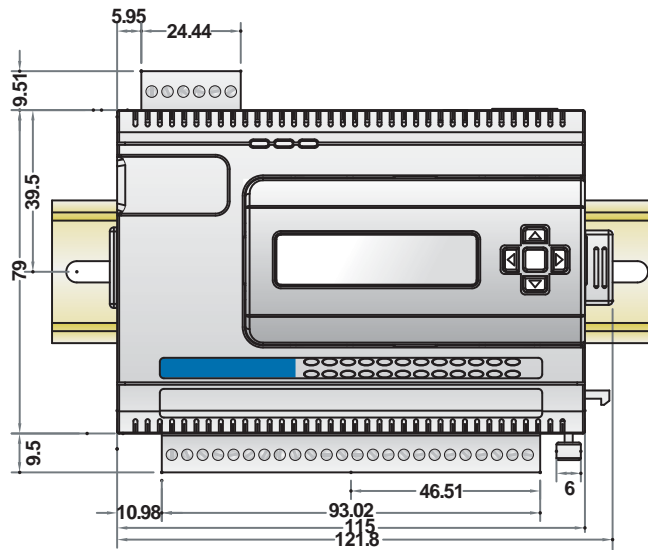
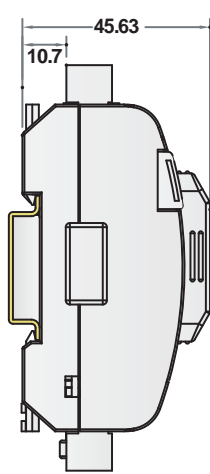

Unit=mm

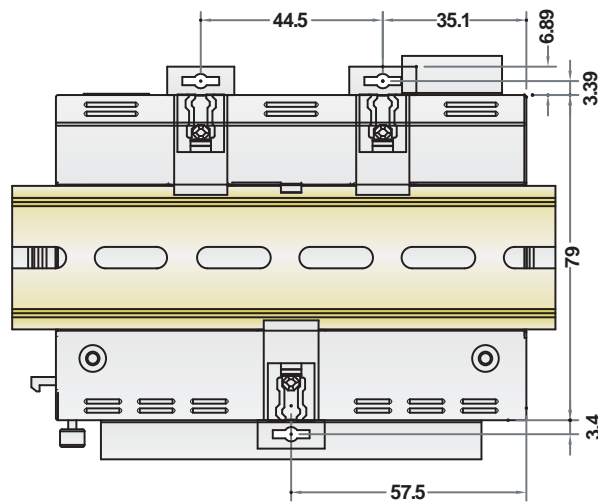

Unit=mm

Hardware Reference

Panel Guide

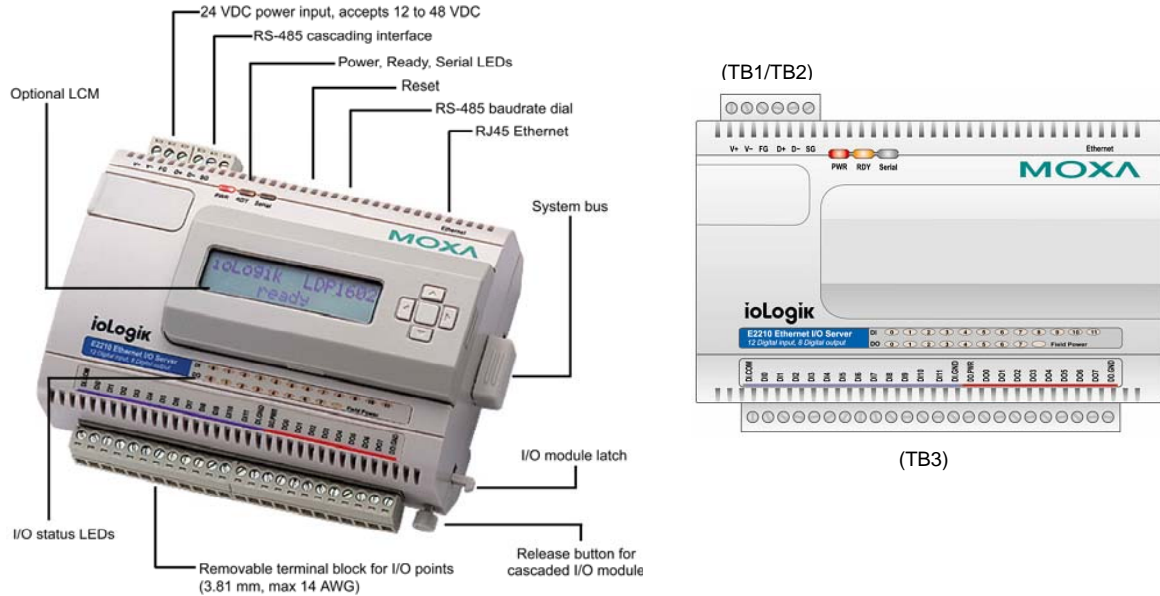

NOTE – The reset button restarts the server and resets all settings to factory defaults. Use a pointed object such as a straightened paper clip to hold the reset button down for 5 sec. The RDY LED will turn red as you are holding the reset button down. The factory defaults will be loaded once the RDY LED turns green again. You may then release the reset button.

LED Indicators

Ethernet		
Ethernet	orange	Connected to a 10 Mbps Ethernet connection.
	green	Connected to a 100 Mbps Ethernet connection.
	(flashing)	Transmitting or receiving data
System		
PWR	red	Power is on
	off	Power is off
RDY	red	System error
	green (steady)	Unit is functioning normally
	green (flashing)	Click&Go ruleset is active
	green & red (flashing)	Unit is in Safe Status
	off	Power is off or there is a power problem.
Serial	(flashing)	Serial port is receiving/transmitting data
I/O		
DI × 12 pins DO × 8 pins	green	ON status
	off	OFF status
DO PWR	red	ON status
	off	No power connected

2

Initial Setup

This chapter describes how to install the ioLogik E2210.

The following topics are covered:

- ❑ **Hardware Installation**
 - Connecting the Power
 - Grounding the ioLogik E2210
 - Connecting to the Network
 - Setting the RS-485 Baudrate
 - Adding More I/O Channels
- ❑ **Software Installation**

Hardware Installation

Connecting the Power

Connect the 12 to 48 VDC power line to the ioLogik E2210's terminal block (TB1). If power is properly supplied, the Power LED will glow a solid red color until the system is ready.



ATTENTION

Disconnect the power before installing and wiring

Disconnect the power cord before installing and/or wiring your ioLogik E2210.

Do not exceed the maximum current for the wiring

Determine the maximum possible current for each power wire and common wire. Observe all electrical codes dictating the maximum current allowable for each wire size.

If the current exceeds the maximum rating, the wiring could overheat, causing serious damage to your equipment.

Grounding the ioLogik E2210

The ioLogik E2210 is equipped with two grounding points, one on the wall mount hole and the other on the DIN-rail mount.

Note that both grounding points are actually connected to the same conducting pathway.

Connecting to the Network

1. Connect the ioLogik E2210 to the host PC with an Ethernet cable. For initial setup of the ioLogik E2210, it is recommended that the ioLogik E2210 be configured using a direct connection to a host computer rather than remotely over the network.
2. Configure the host PC's IP address to 192.168.127.xxx. (xxx: from 001 to 253). In Windows, you will need to do this through the Control Panel.

ioLogik E2210 Default IP Address	Default Netmask	Default Gateway
192.168.127.254	255.255.255.0	None

3. Use ioAdmin or the web console to detect the ioLogik E2210. Once the ioLogik E2210 has been detected, modify the settings as needed for your network environment, then restart the server.

Setting the RS-485 Baudrate

The RS-485 port on the ioLogik E2210 is reserved to chain another RS-485 I/O server. The RS-485 port can run Modbus/RTU or I/O command sets. The baudrate is set by a physical dial on the back of the ioLogik E2210. The default settings are baudrate = 115200, parity check = N, data bits = 8, and stop bit = 1.

	Baudrate for RS-485 (parameters are N, 8, 1)	Dial setting and corresponding baudrate:			
		0:115200	1:57600	2:38400	3:19200
		4:9600	5:4800	6:2400	7:1200

Remember to restart the ioLogik E2210 after making any changes to the RS-485 baudrate.

Adding More I/O Channels

A cost-effective way to add more I/O channels to your ioLogik E2000 I/O server is to attach the appropriate ioLogik R2000 I/O server. The two servers can be snapped together using the RS-485 system bus connector, as shown in the following figure. For the ioLogik E2210, additional digital I/O channels are added using the ioLogik R2110. For additional details, please refer to the ioLogik R2110 user's manual.



Software Installation

ioAdmin is a Windows utility provided for the configuration and management of the ioLogik E2210 and attached I/O devices. It may be used from anywhere on the network to monitor and configure the ioLogik E2210. You may also configure some of the settings through the web console or optional LCM.

1. **Installation from CD:** Insert the Document and Software CD into the host computer. In the root directory of the CD, locate and run SETUP.EXE. The installation program will guide you through the installation process and install the ioAdmin utility. You can also install the MXIO DLL library or ioEventLog separately.
2. **Open ioAdmin:** After installation is finished, run **ioAdmin** from **Start → Program Files → MOXA → IO Server → Utility → ioAdmin**.
3. **Search the network for the server:** On the menu bar, select **System → Auto Scan Active Ethernet I/O Server**. A dialog window will pop up. Click **Start Search** to begin searching for the ioLogik E2210.

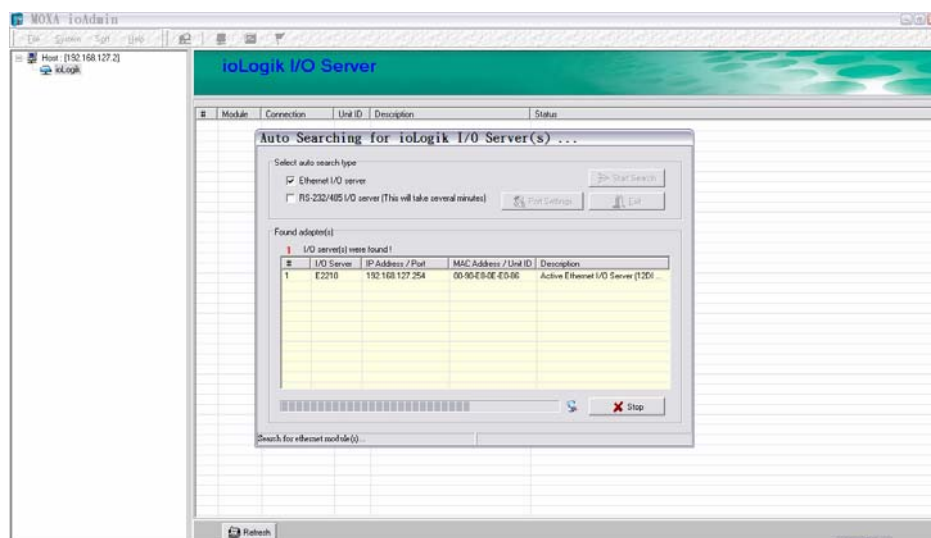

If ioAdmin is unable to find the ioLogik E2210, there may be a problem with your network settings.

If multiple ioLogik E2000 units are installed on the same network, remember that each unit has the same default IP address. You will need to assign a different IP address to each unit to avoid IP conflicts. ioAdmin automatically detects IP conflicts and gives you a chance to modify each unit's IP address in the "IP Address" columns. Click the "Set" button to reboot the corresponding unit with its new IP address. Click the "Re-Search" button to refresh the list of units found by ioAdmin.

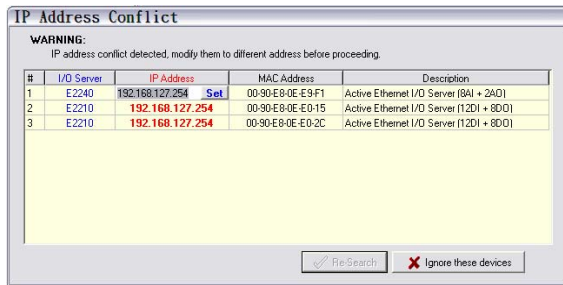

4. **Monitoring I/O status:** Once the ioLogik E2210 is found by ioAdmin, you may view the status of all I/O devices on ioAdmin's main screen.

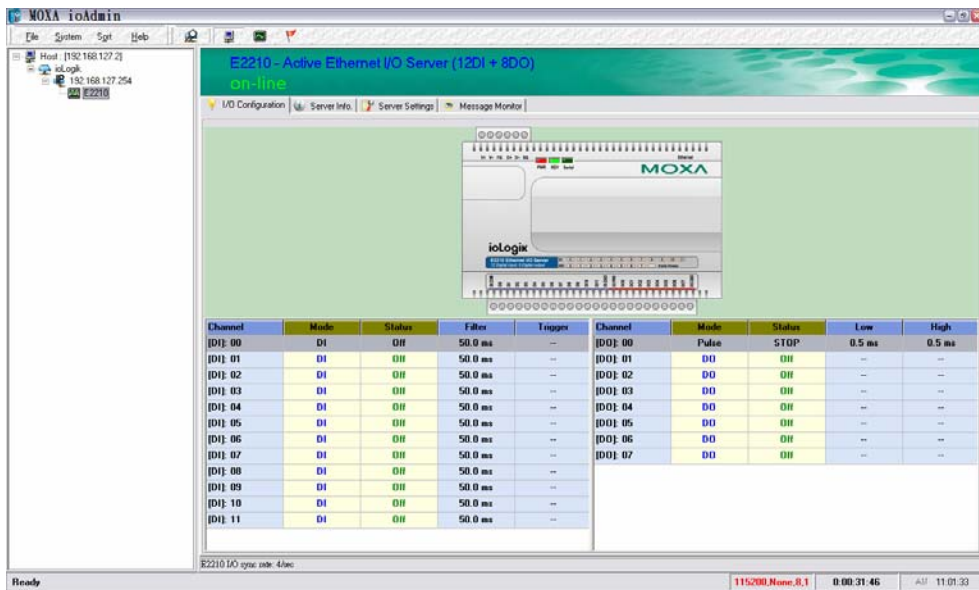

You may now use ioAdmin to set up or configure your ioLogik E2210.

This chapter goes over the functions available in ioAdmin, the ioLogik E2210's main configuration and management utility.

The following topics are covered:

- ❑ **Introduction to ioAdmin**
- ❑ **Features of ioAdmin**
- ❑ **ioAdmin Main Screen**
 - Main Screen Overview
 - Wiring Guide
- ❑ **Main Items**
- ❑ **Main Window**
 - I/O Configuration Tab (General)
 - Server Info Tab
 - Server Settings Tab (General)
 - Message Monitor Tab
- ❑ **ioAdmin Administrator Functions**
 - I/O Configuration Tab (Administrator)
 - Server Settings Tab (Administrator)
 - Network Tab
 - Firmware Update Tab
 - Watchdog Tab
 - Click&Go Logic Tab
- ❑ **Server Context Menu**
- ❑ **Using TFTP to Import/Export Configuration**
- ❑ **Using ioEventLog**
 - Installing ioEventLog
 - Basic Functions
 - Configuration
 - Checking Connected Devices
 - Opening Log Files
 - Clearing the Log

Introduction to ioAdmin

The ioLogik I/O server may be managed and configured over the Ethernet by ioAdmin, a Windows utility provided with your ioLogik E2210. ioAdmin's graphical user interface gives you easy access to all status information and settings.

The ioLogik E2210 also supports configuration by web console and by optional LCM, but full configuration and management is only available through ioAdmin.

A new feature in ioAdmin automatically detects IP conflicts between ioLogik E2000 units. If ioAdmin detects an IP conflict, a window will appear that allows you to resolve the IP conflict immediately and restart each unit.

ioAdmin also includes Click&Go logic control for the configuration of your Active Ethernet I/O system.

ioAdmin consists of following software:

- **ioAdmin with Click&Go Logic**
- **ioLogik 2000 Wiring Guide**
- **ioLogik 4000 Wiring Guide**

Features of ioAdmin

Remote Management

Over the Ethernet network, ioAdmin allows users to

- find and configure multiple ioLogik servers.
- monitor and configure attached I/O devices.
- test I/O devices.
- reset the server.

On-line Wiring Guide

An on-line wiring guide can be opened from within ioAdmin for your convenience. The easily accessible wiring guide can save administrators much time while planning or troubleshooting.

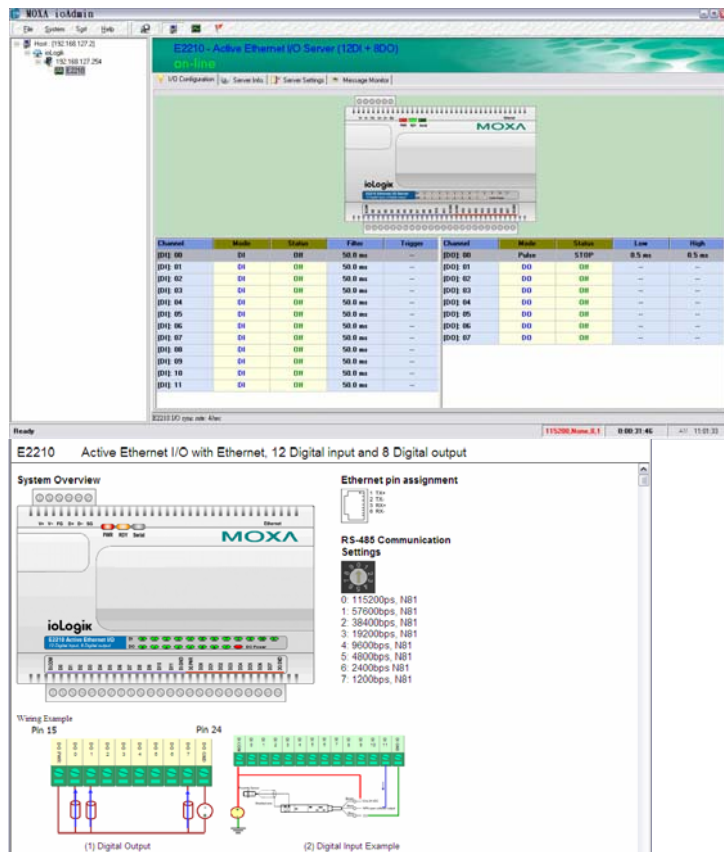

Configuration File

ioAdmin allows the entire configuration of the ioLogik E2210 to be saved as a file. The file is viewable as text and can serve three purposes:

- as a record or backup of configuration
- as a template for the configuration of other servers
- as a quick reference guide for you to configure Modbus drivers in a SCADA system

The file includes the following information:

- file title, date, and time
- model information
- Modbus address

Server Management List

ioAdmin can import and export a list of ioLogik servers that are being managed. This file can make it easier to manage all devices on the network, and includes the following information:

- server name
- module type
- IP address
- unit ID

```
Time: 9:10:55 AM
-----
[1. Model]
-----
MOD_TYPE=E2210 - Active Remote I/O Server (12DI + 8Do)
MOD_LOC=
MOD_NAME=
-----
[2. I/O Configurations]
-----
DI00=0, (DI),          DI00_FILTER=100, (50.00ms)
DI01=0, (DI),          DI01_FILTER=100, (50.00ms)
DI02=0, (DI),          DI02_FILTER=100, (50.00ms)
DI03=0, (DI),          DI03_FILTER=100, (50.00ms)
DI04=0, (DI),          DI04_FILTER=100, (50.00ms)
DI05=0, (DI),          DI05_FILTER=100, (50.00ms)
DI06=0, (DI),          DI06_FILTER=100, (50.00ms)
DI07=0, (DI),          DI07_FILTER=100, (50.00ms)
DI08=0, (DI),          DI08_FILTER=100, (50.00ms)
DI09=0, (DI),          DI09_FILTER=100, (50.00ms)
DI10=0, (DI),          DI10_FILTER=100, (50.00ms)
DI11=0, (DI),          DI11_FILTER=100, (50.00ms)

DO00=0, (DO),          DO00_PWN=0, (OFF),          DO00_SAFE=0, (OFF)
DO01=0, (DO),          DO01_PWN=0, (OFF),          DO01_SAFE=0, (OFF)
DO02=0, (DO),          DO02_PWN=0, (OFF),          DO02_SAFE=0, (OFF)
DO03=0, (DO),          DO03_PWN=0, (OFF),          DO03_SAFE=0, (OFF)
DO04=0, (DO),          DO04_PWN=0, (OFF),          DO04_SAFE=0, (OFF)
DO05=0, (DO),          DO05_PWN=0, (OFF),          DO05_SAFE=0, (OFF)
DO06=0, (DO),          DO06_PWN=0, (OFF),          DO06_SAFE=0, (OFF)
DO07=0, (DO),          DO07_PWN=0, (OFF),          DO07_SAFE=0, (OFF)
-----
[3. Modbus address table]
-----
CHANNEL      I/O TYPE      MODEBUS REFERENCE      MODBUS ADDRESS (Dec, Hex)
DI00          Input         10001                   0000, 0x0000
DI01          Input         10002                   0001, 0x0001
DI02          Input         10003                   0002, 0x0002
DI03          Input         10004                   0003, 0x0003
DI04          Input         10005                   0004, 0x0004
DI05          Input         10006                   0005, 0x0005
DI06          Input         10007                   0006, 0x0006
DI07          Input         10008                   0007, 0x0007
DI08          Input         10009                   0008, 0x0008
DI09          Input         10010                   0009, 0x0009
DI10          Input         10011                   0010, 0x000A
```

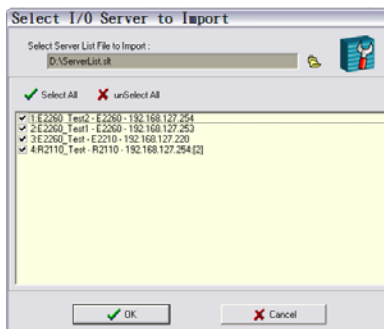

ioAdmin Main Screen

Main Screen Overview

This is ioAdmin's main screen. The main window defaults to the I/O Configuration tab, which displays a figure of the ioLogik E2210 and the status of every I/O channel below it. The other tabs in the main window take you to server and network settings, and further functions are available when you log on as an administrator. Note that configuration options are not available until you log on as an administrator.

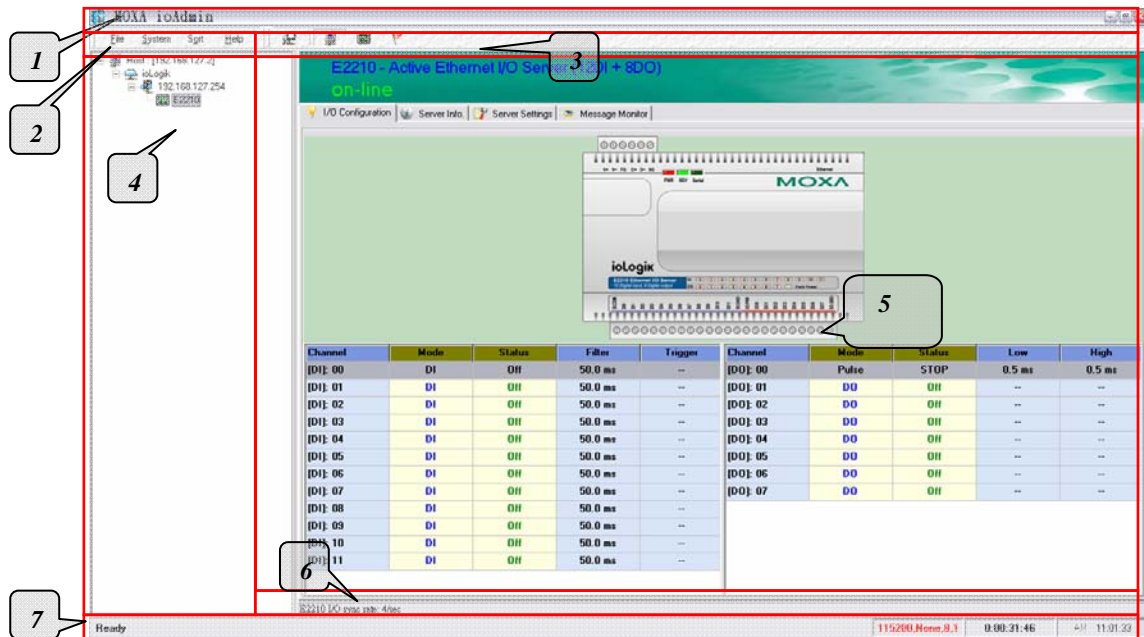

ioAdmin Main Screen	
1.	Title
2.	Menu bar
3.	Quick link
4.	Navigation panel
5.	Main window
6.	Sync. rate status
7.	Status bar

Wiring Guide

ioAdmin provides a wiring guide to the ioLogik E2210. You may access the wiring guide by right-clicking the figure of the ioLogik E2210 in the I/O Configuration tab. Select "Wiring Guide" in the submenu to open a help file showing the wiring information and electrical characteristics of the ioLogik E2210.

System Overview

The diagram shows the physical layout of the ioLogik E2210. It features a top panel with status LEDs (V+, V-, FG, D+, D-, SG) and a PWR, RDY, Serial indicator. The front panel includes an Ethernet port and a row of 24 digital I/O pins labeled DI0 through DI23. The bottom panel shows a row of 24 digital output pins labeled DO0 through DO23.

Ethernet pin assignment

The diagram shows the pin assignment for the Ethernet port:

- 1: TX+
- 2: TX-
- 3: RX+
- 6: RX-

RS-485 Communication Settings

The diagram shows the RS-485 communication settings:

- 0: 115200ps, N81
- 1: 57600bps, N81
- 2: 38400bps, N81
- 3: 19200bps, N81
- 4: 9600bps, N81
- 5: 4800bps, N81
- 6: 2400bps, N81
- 7: 1200bps, N81

Wiring Example

Pin 15

Pin 24

(1) Digital Output

(2) Digital Input Example

You may also access the On-line Wiring Guide through the Help menu on the menu bar.

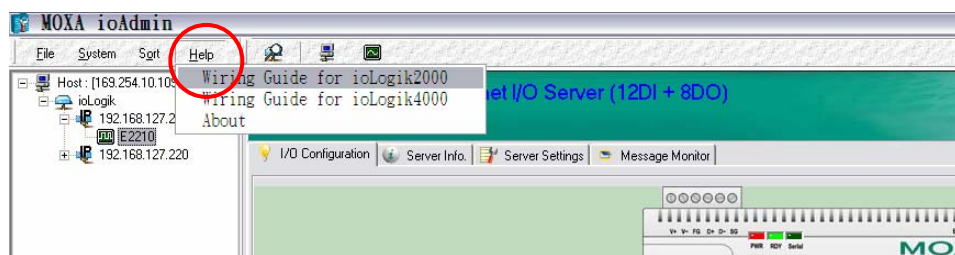

Main Items

File

From the **File** menu, you can export the list of I/O servers that are currently displayed in the navigation panel. You also can import a list of I/O servers into ioAdmin.

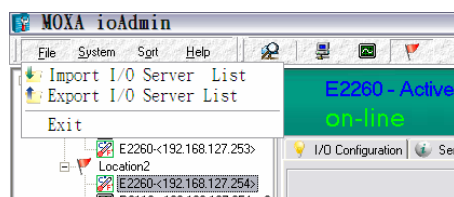

When importing a server list, you will be prompted to select which servers on the list need to be imported.

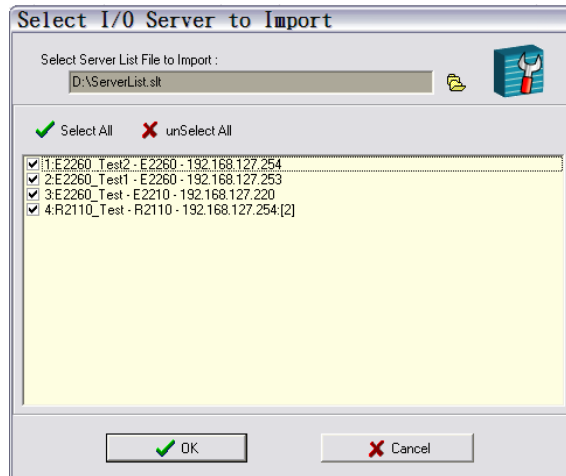

The file will have a .SLT extension and can be opened as a text file. The server list will provide the following information for each server:

- server name
- module type
- IP address
- unit ID

System

Several operations are possible from the **System** menu.

Auto Scan Active Ethernet I/O Server will search for ioLogik servers on the network. When connecting for the first time or recovering from a network disconnection, you can use this command to find I/O servers that are on the network.

Network Interface allows you to select a network to use, if the PC has multiple network adapters installed.

I/O Status Refresh Rate is used to adjust how often the I/O server is polled for device status. The current rate is displayed on the status bar at the bottom of the window. Note that higher sync rates result in higher loads on the network.

TCP Socket Timeout Interval allows you to select the preferred timeout value for TCP socket communication.

COM Port Setting is used to set the parameters for Modbus communication, such as baudrate, data bits, and timeout interval. For most applications, this will involve connecting to ioLogik R-Series devices.

Active Message Listen Port specifies the port number to use for Active Ethernet I/O messages. If your network uses a firewall, you can coordinate this setting with your firewall settings to ensure that active messages get through.

Reset NA4010 Network Adapter IP is used to re-assign an IP address to the NA-4010 network adapter, for ioLogik 4000 systems.

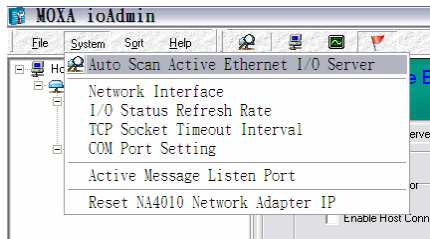

Sort

The **Sort** menu allows the server list in the navigation panel to be sorted by connection, type, and location.

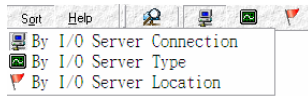

Help



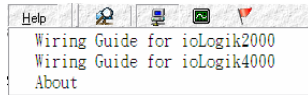

In the **Help** menu, you can view wiring guides and information about ioAdmin.



Quick Links

Quick links are provided to search for I/O servers on the network and sort the server list.



	Search network for I/O servers
	Sort by connection
	Sort by I/O server type
	Sort by location

Main Window

I/O Configuration Tab (General)

The **I/O Configuration** tab shows the status of every I/O channel. This is the default tab when you first open ioAdmin.

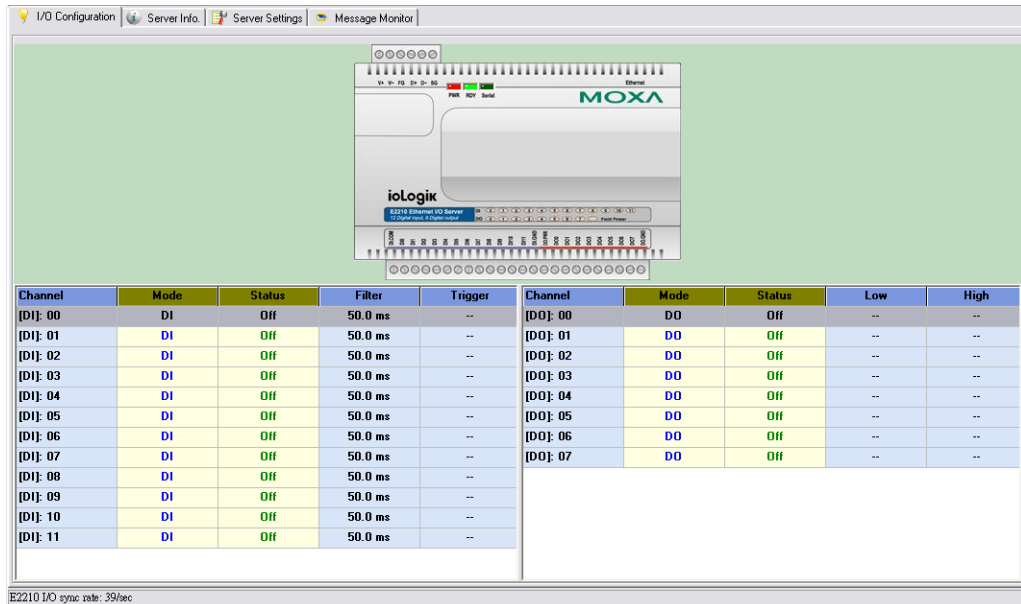

Server Info Tab

Server information, such as firmware revision, is displayed in the **Server Info** tab.

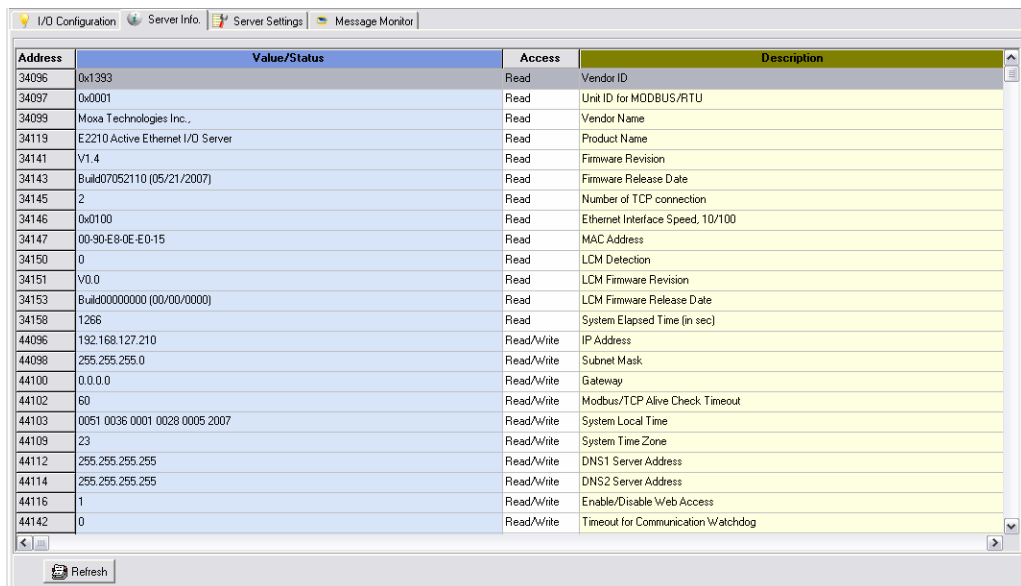

Server Settings Tab (General)

The **Server Settings** tab is where you log in as an administrator. This is required in order to gain access to the ioLogik E2210 configuration options. If no administrator password has been set up, simply click on **Login** and leave the **Password for entry** field blank. Additional detail is provided later in this chapter.

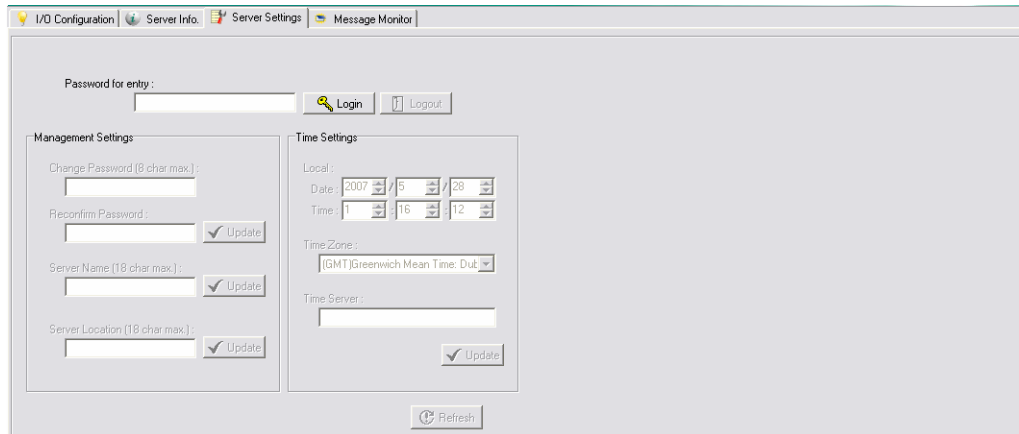

Message Monitor Tab

The **Message Monitor** tab will display any TCP/UDP I/O messages received from the ioLogik E2210. When you install the ioLogik E2210 for the first time, the active I/O messaging ruleset will not have been defined yet, so there will be no messages in the Message Monitor Tab. Please refer to Chapter 5 for information on how to program the ioLogik E2210's active I/O messaging system. Once the active I/O messaging system has been configured and activated, TCP/UDP messages sent from the ioLogik E2210 will be viewable in the Message Monitor tab.

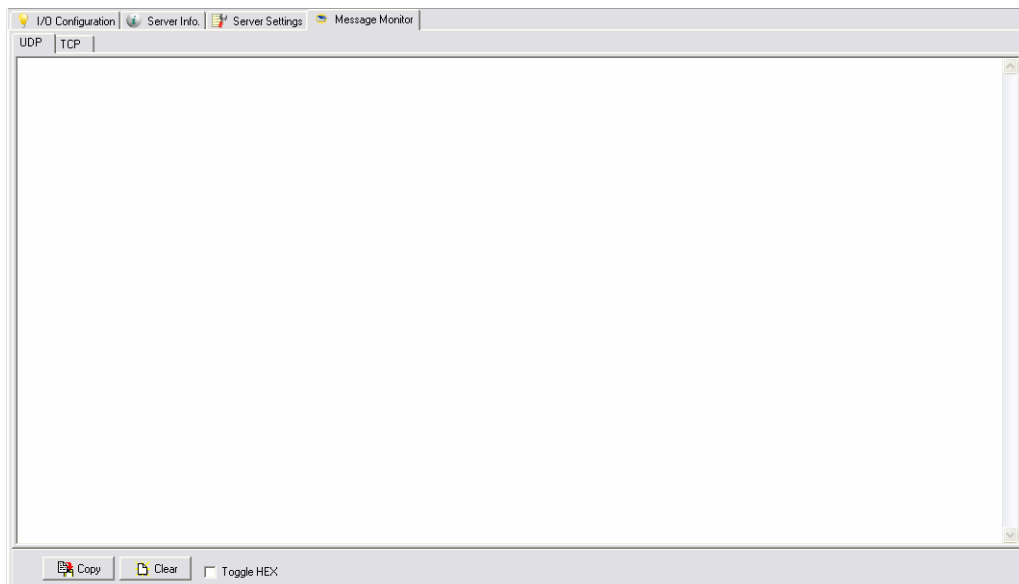

Messages can be displayed in ASCII or in HEX. To display messages in HEX, make sure that "Toggle HEX" is checked.

ioAdmin Administrator Functions

For full access to all configuration options, log in as an administrator in the Server Settings tab. This is required whenever you start up ioAdmin or boot up/restart the ioLogik E2210. When you install the ioLogik E2210 for the first time, the password will be blank and you may simply click on **Login**. Additional functions will be available after logging in, including the following new tabs:

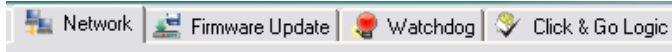

When making configuration changes, you will need to click on **Update** or on **Apply** to save the changes. Some changes will require a restart of the ioLogik E2210 in order to take effect, and you will be given the option to restart the computer if necessary.

ATTENTION



You must log in to access any administrator function, including Network, Communication Watchdog Timer, and Firmware Update tabs. If you forget the password, you may hold down the ioLogik's reset button to clear the password and load factory defaults. **This will result in the loss of all configuration settings and your Click&Go Logic active I/O messaging program!**

I/O Configuration Tab (Administrator)

When logged on as an administrator, you may double click on a channel in the **I/O Configuration** tab to configure that channel's settings. A window will open with configuration options for that channel. Settings made in this window can be copied to all I/O channels using the "Apply to all channels" option. Options for Power On Settings and Safe Status Settings are also available.

Configuring Digital Input Channels

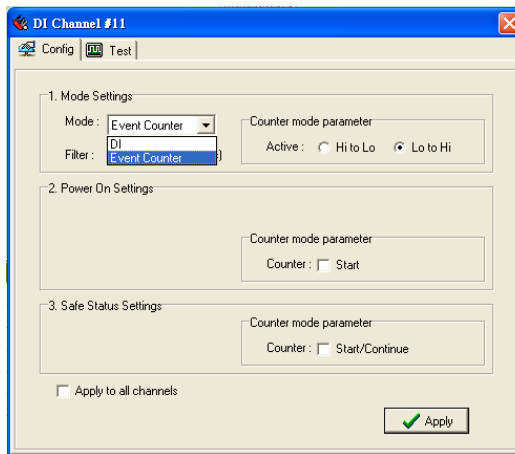

The E2210 is equipped with 12 DI (digital input) channels that can be separately set to "DI" or "Event Counter Mode." In DI mode, the specifications are as follows:

Type	Logic 0 (OFF)	Logic 1 (ON)
Dry contact	close to GND	open
Wet contact	0 to 3 V	10 to 30 V

In Event Counter mode, the ioLogik E2210's DI channel accepts limit or proximity switches and counts events according to the ON/OFF status. You may select from two modes, "Lo to Hi" or "Hi to Lo"

Lo.” When “Lo to Hi” is selected, the counter value increases while the switch is pushed. When “Hi to Lo” is selected, the counter value increases when the switch is push and released.

To control switch bounces, the ioLogik E2210 provides software filtering. It is configurable in multiples of 0.5 ms. For example, a setting of 2 would mean a 1 ms filter (2 × 0.5 ms). The maximum value allowed by the software filter is 65535.

NOTE: “1” is the minimum filter value.

Configuring Digital Output Channels

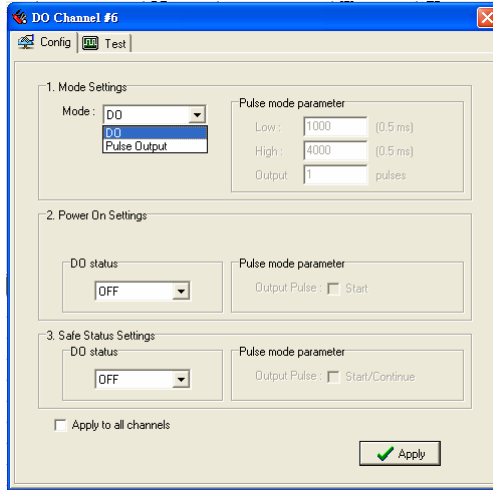

The ioLogik E2210 is equipped with 8 DO (digital output or sink) channels that can be set individually to “DO” or “Pulse Output” mode.

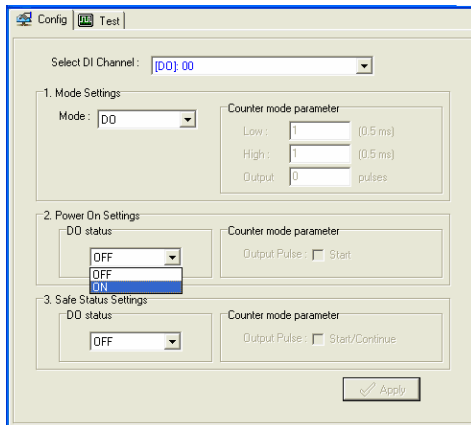

In DO mode, the specification is as follows.

Type	Logic 0 (OFF)	Logic 1 (ON)
DO mode	Open	Short

In Pulse Output mode, the selected digital output channel will generate a square wave as specified in the pulse mode parameters. The low and high level widths are entered in multiples of 0.5ms, with a maximum setting of 65,535 (32,767 ms). To set the low level width for 500 ms, you would enter 1000 (because 1000 × 0.5 ms = 500 ms). If the low width value is 5000 and the high width value is 5000, the pulse output would be a square wave with a 5-second pulse cycle. If continuous pulse

output is desired, enter “0” for the number of pulses, otherwise enter the desired number of pulses between 1 and 4,294,967,295.

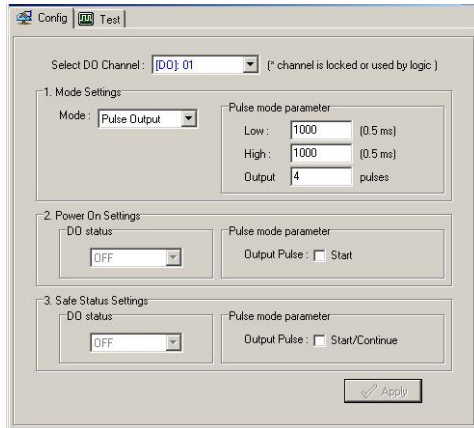

Power On Settings

Use this field to set the initial behavior of the DI/O channel when the ioLogik E2210 is powered on. For DI channels in Event Counter mode, you may configure whether or not counting begins at power up. For DO channels in DO mode, you may configure whether or not the DO is set to OFF or ON at power up. For DO channels in Output Pulse mode, you may configure whether or not the pulse output commences at power up.

Safe Status Settings

Use this field to specify how the DI/O channel behaves when the network connection is lost. When the network connection is lost for the amount of time specified in the Host Connection Watchdog, the ioLogik E2210 enters Safe Status, and each DI/O channel's Safe Status settings will go into effect. Note that the Host Connection Watchdog is disabled by default. If the Host Connection Watchdog is disabled, the ioLogik E2210 will never enter Safe Status and the Safe Status settings will have no effect.

For DI channels in Event Counter mode, you can configure whether or not counting starts or continues when Safe Status has been activated. For DO channels in DO mode, you can configure whether or not the DO is set to OFF or ON at Safe Status. For DO channels in Output Pulse mode, you can configure whether or not the output pulse commences or continues at Safe Status.

Test I/O

You may test the DI/O channel by using ioAdmin.

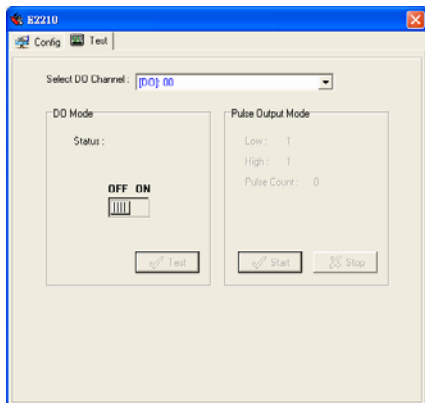

- DI-DI: show the channel's status
- DI-Counter: start or stop the counter
- DO-DO: set the DO to "ON" or "OFF"
- DO-Pulse: activate or stop pulse generation.

Server Settings Tab (Administrator)

You may set up a password, server name, location, date, time zone, and time server in the Server Settings tab. ioAdmin supports long server names and a location description up to 58 chars. If you will be using ioEventLog to receive server status reports, such as for warm or cold starts, indicate the IP address and port number for the PC that will be running ioEventLog in the "System Log" field. The default port number is 4040.

For additional information, please refer the ioEventLog section later in this chapter.

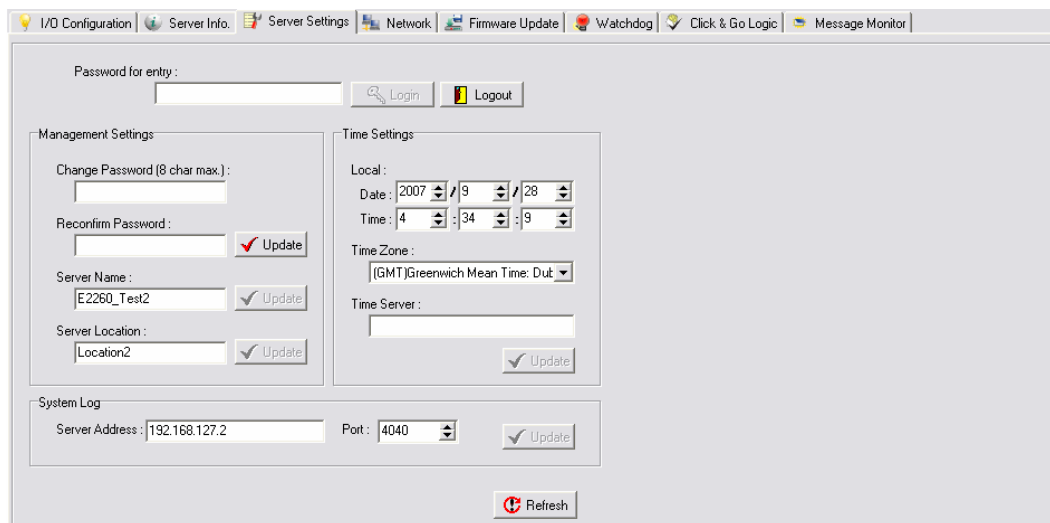

Network Tab

The **Network** tab is where you configure IP settings, Modbus/TCP Alive Check Timeout settings, DNS settings, Serial settings, SNMP settings, and Web Access settings for the ioLogik E2210.

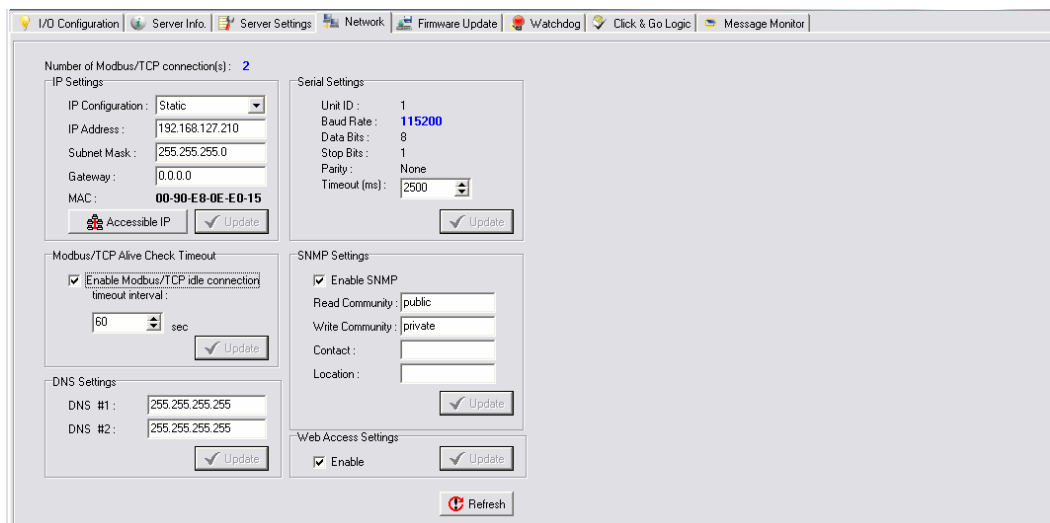

IP Settings: You can set up a static or dynamic IP address for the ioLogik E2210, as well as the subnet mask and gateway address. The **Accessible IP** screen can be used to control network access to the ioLogik E2210 and attached sensors. Network requests that originate from sources that are not listed in the accessible IP list will be unable to use Modbus/TCP or ioAdmin to access the ioLogik E2210.

Modbus/TCP Alive Check Timeout Settings: The Modbus/TCP Alive Check Timeout is designed to avoid TCP connection failure. When the host is down, the ioLogik E2210 will continue to wait for a response from the host. This will cause the TCP port to be indefinitely occupied by the host. When the Modbus/TCP idle connection timeout interval is enabled, the ioLogik E2210 will close the TCP connection automatically if there is no TCP activity for the specified time. Please note that Modbus/TCP connections will be blocked when setting up Accessible IP.

DNS Settings: Use this field to specify up the IP addresses of up to 2 DNS servers. These two DNS servers may be used to automatically find available e-mail addresses when configuring for Active Ethernet I/O e-mail messaging.

Serial Settings: You may view the reserved RS-485 communication parameters here, and you may set the timeout value for breaks in RS-485 communication. Note that the other serial communication parameters cannot be modified. If you wish to adjust the baudrate, you will need to use the physical dial on the back panel of the ioLogik E2210.

SNMP Settings: The ioLogik E2210 provides SNMP v2 (Simple Network Management Protocol) to allow monitoring of network and I/O devices with SNMP Network Management software. It is useful in building automation and telecom applications. Use these fields to enable SNMP and set the read and write community strings.

Web Access Settings: This field enables and disables the ioLogik E2210's web console. The web console allows the configuration of many settings using a web browser that is directed to the server's IP address. If the web console is not enabled in this field, you will not be able to access the web console.

Firmware Update Tab

The ioLogik E2210 supports remote firmware updates through the **Firmware Update** tab. Enter the path to the firmware file or click on the icon to browse for the file. Click **Update** to update the firmware. The wizard will lead you through the process until the server is restarted.

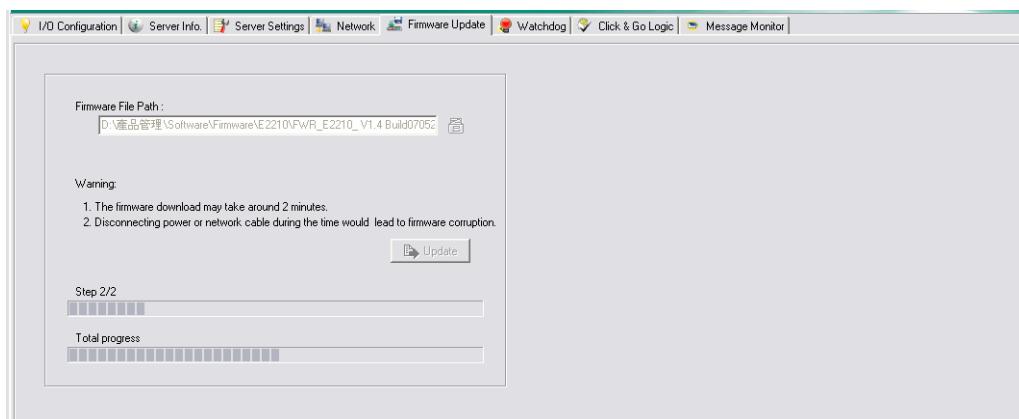



WARNING

Do not interrupt the firmware update process! An interruption in the process may result in your device becoming unrecoverable.

After the firmware is updated, the ioLogik will restart and you will have to log in again to access administrator functions.

The firmware on any attached I/O expansion module, such as an ioLogik R2000 server, must be updated over the RS-485 bus. Firmware on cascaded modules cannot be updated over Ethernet.

Watchdog Tab

The **Watchdog** tab is where you configure the Host Connection Watchdog, which is used with the Safe Status settings to define each DI/O channel's response to a lost network connection. When the ioLogik E2210 loses its network connection for the amount of time specified in the timeout, the Host Connection Watchdog will switch the ioLogik E2210 to Safe Status and the DI/O channels will reset to their Safe Status settings. By default, the Watchdog is disabled. To enable the Watchdog, make sure **Enable Host Connection Watchdog** is checked, set the Timeout value, then click the **Update** button.

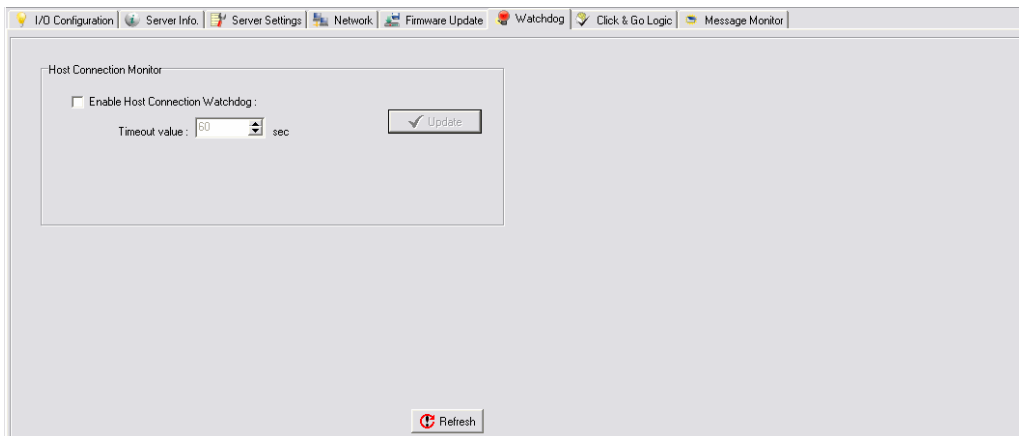

After the Watchdog is enabled, the ioLogik E2210 will enter safe status if the network connection is lost. Once the connection has been restored, you will need to return to the Watchdog Tab in order to exit safe status. There will be a message saying "Host Connection Lost", indicating that the server is in safe status. Click **Clear Alarm** to exit safe status and return to normal operation.

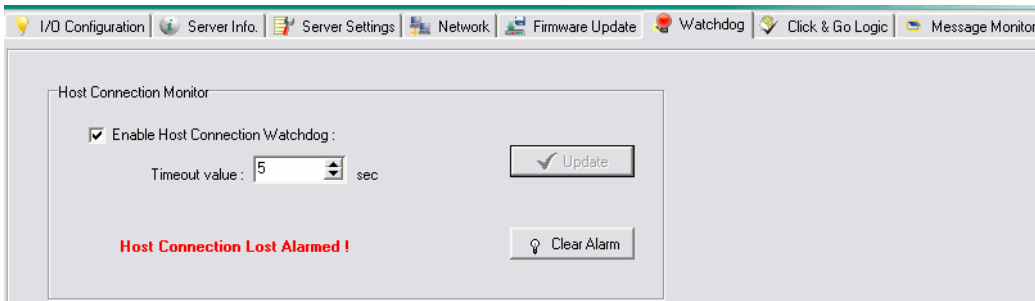

Click&Go Logic Tab

The **Click&Go Logic** tab is where administrators set up the ioLogik E2210's active I/O messaging program. Instead of the server reacting passively to repeated polling request from a host for I/O data, the ioLogik E2210 is able to actively send I/O information to the host when an I/O channel satisfies conditions that you specify. Click&Go Logic was developed by Moxa to provide a powerful and easy-to-use tool for defining the conditions under which I/O information will be sent over the network. Please refer to Chapter 5 for more detailed information.

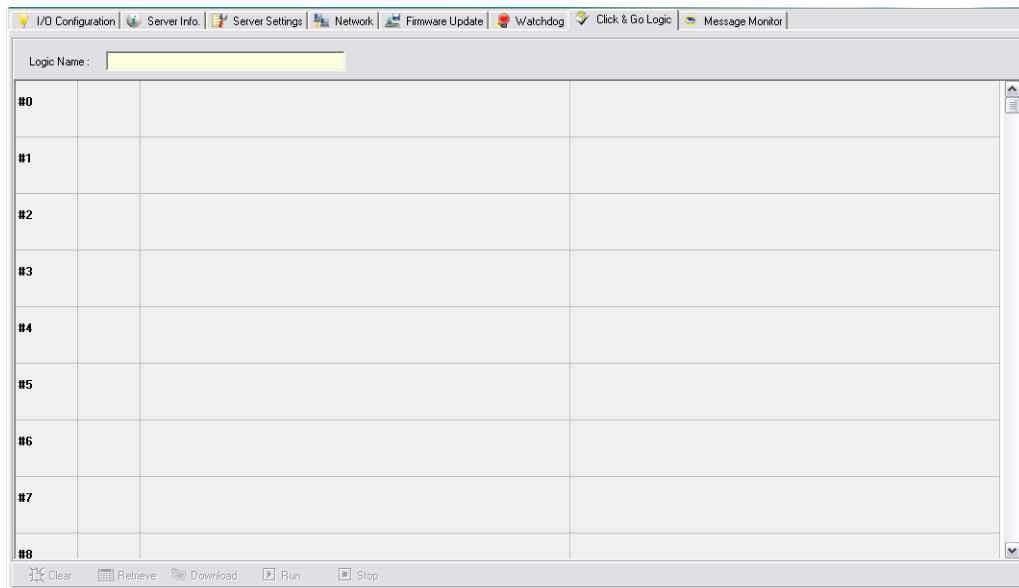

Changes made in the Click&Go Logic tab are not effective until the ioLogik E2210 is restarted, just like changes made in other tabs. Note that when Click&Go Logic is being used, the range and units of I/O channel being used in Click&Go Logic may not be modified.

Server Context Menu

The server context menu is accessed by right clicking on the server model name in the navigation panel.

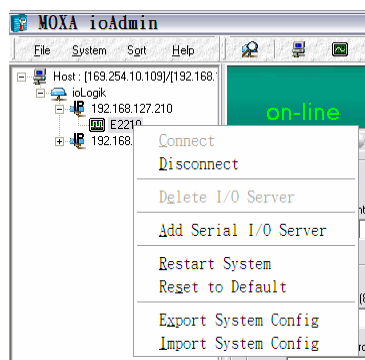

Connect

Select this command to have ioAdmin attempt a re-connection over the network to the selected ioLogik server.

Disconnect

Select this command to have ioAdmin drop the network connection with the selected ioLogik server.

Delete I/O Server

Select this command to have ioAdmin remove the selected server.

Add Serial I/O Server

Select this command to manually add a server by using its Unit ID.

Restart System

Select this command to restart your ioLogik E2210 from a remote site. You will need to log in as an administrator to use this function.

Reset to Default

Select this command to reset all settings, including console password, to factory default values. You will need to log in as an administrator to use this function.

Export System Config

Select this command to export the configuration of the ioLogik E2210 to a text file. You will need to log in as an administrator to use this function. It is strongly recommended you use this method to back up your configuration after you have finished configuring the ioLogik E2210 for your application.

Below is an example of the exported configuration file

```

Time: 9:10:55 AM
[1. Model]
-----
MOD_TYPE=E2210 - Active Remote I/o Server (12DI + 8DO)
MOD_LOC=
MOD_NAME=

[2. I/o Configurations]
-----
DI00=0, (DI),          DI00_FILTER=100, (50.00ms)
DI01=0, (DI),          DI01_FILTER=100, (50.00ms)
DI02=0, (DI),          DI02_FILTER=100, (50.00ms)
DI03=0, (DI),          DI03_FILTER=100, (50.00ms)
DI04=0, (DI),          DI04_FILTER=100, (50.00ms)
DI05=0, (DI),          DI05_FILTER=100, (50.00ms)
DI06=0, (DI),          DI06_FILTER=100, (50.00ms)
DI07=0, (DI),          DI07_FILTER=100, (50.00ms)
DI08=0, (DI),          DI08_FILTER=100, (50.00ms)
DI09=0, (DI),          DI09_FILTER=100, (50.00ms)
DI10=0, (DI),          DI10_FILTER=100, (50.00ms)
DI11=0, (DI),          DI11_FILTER=100, (50.00ms)

DO00=0, (DO),          DO00_PWN=0, (OFF),          DO00_SAFE=0, (OFF)
DO01=0, (DO),          DO01_PWN=0, (OFF),          DO01_SAFE=0, (OFF)
DO02=0, (DO),          DO02_PWN=0, (OFF),          DO02_SAFE=0, (OFF)
DO03=0, (DO),          DO03_PWN=0, (OFF),          DO03_SAFE=0, (OFF)
DO04=0, (DO),          DO04_PWN=0, (OFF),          DO04_SAFE=0, (OFF)
DO05=0, (DO),          DO05_PWN=0, (OFF),          DO05_SAFE=0, (OFF)
DO06=0, (DO),          DO06_PWN=0, (OFF),          DO06_SAFE=0, (OFF)
DO07=0, (DO),          DO07_PWN=0, (OFF),          DO07_SAFE=0, (OFF)

[3. Modbus address table]
-----
CHANNEL      I/O TYPE      MODBUS REFERENCE      MODBUS ADDRESS (Dec, Hex)
DI00          Input          10001                  0000, 0x0000
DI01          Input          10002                  0001, 0x0001
DI02          Input          10003                  0002, 0x0002
DI03          Input          10004                  0003, 0x0003
DI04          Input          10005                  0004, 0x0004
DI05          Input          10006                  0005, 0x0005
DI06          Input          10007                  0006, 0x0006
DI07          Input          10008                  0007, 0x0007
DI08          Input          10009                  0008, 0x0008
DI09          Input          10010                  0009, 0x0009
DI10          Input          10011                  0010, 0x000A

```

Import System Config

Select this command to reload a configuration that was exported to a text file. You will need to log in as an administrator to use this function. You will need to restart the ioLogik E2210 in order for the new configuration to take effect. This command may be used to restore a configuration after loading the factory defaults, or to duplicate a configuration to multiple ioLogik servers.

Using TFTP to Import/Export Configuration

TFTP (Trivial File Transfer Protocol) was defined in 1980 to provide basic FTP functionality in a very simple protocol. Due to TFTP's simplicity, it can be implemented using a very small amount of memory, an important consideration when it was first developed. ioLogik E2000 I/O servers support the use of TFTP to import or export configuration files.

The following is an example using Windows TFTP and an ioLogik E2210 with an IP address of 192.168.127.254:

1. Enter "TFTP 192.168.127.254 GET ik2210.txt" to get the ioLogik's configuration file.
2. Enter "TFTP 192.168.127.254 PUT ik2210.txt" to load a configuration file onto the ioLogik

You must use "**ik2210.txt**" as the destination filename when copying a configuration file to the ioLogik E2000 unit. Otherwise, you will receive an error message as shown below:

```

Error on server : ioServer - Fail to write file !.cess Protocol
pcmail-srv      158/tcp          #PCMail Server
snmp            161/udp          #SNMP
snmptrap        162/udp          snmp-trap      #SNMP trap
print-srv       170/tcp          #Network PostScript
bgp             179/tcp          #Border Gateway Protocol
irc            194/tcp          #Internet Relay Chat Protocol
l
ipx            213/udp          #IPX over IP
ldap           389/tcp          #Lightweight Directory Access
s Protocol
https          443/tcp          MCom
https          443/udp          MCo
https          443/tcp          MCom
https          443/udp          MCo?
  
```

You can use TFTP in a batch file to transfer configuration files for different units. For example, you might have two configuration files that need to be copied to two different servers: **ik2210_1.txt** for 192.168.127.253, and **ik2210_2.txt** for 192.168.127.254. A batch file could be written as follows:

```
tftp 192.168.127.253 put ik2210_1.txt ik2210.txt
```

```
tftp 192.168.127.254 put ik2210_2.txt ik2210.txt
```



ATTENTION

You can also run TFTP client software, open the configuration file, and enter the remote server's IP. Note that both ASCII and Octet mode are supported. When the download process is complete, the I/O server will reboot.

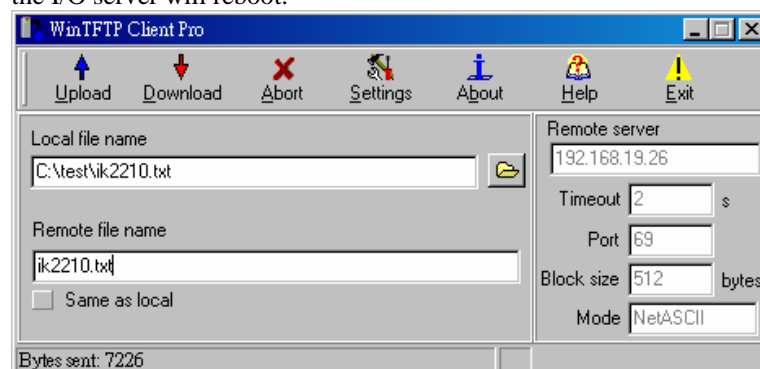

WinTFTP Client Pro is a trademark of WinTFTP. All rights reserved.

Using ioEventLog

Installing ioEventLog

ioEventLog is a Windows utility that can be used anywhere on the network to monitor the ioLogik E2210.

1. **Installation from CD:** Insert the Document and Software CD into the host computer. Run SETUP.EXE, which is located in the root directory. The installation program will guide you through the installation process and install the ioEventLog utility.
2. **Open ioEventLog:** After installation is finished, run **ioEventLog** from **Start → Program Files → MOXA → IO Server → Utility → ioEventLog**.

Basic Functions

ioEventLog is installed along with ioAdmin from the Document and Software CD. It is designed to help you keep a record of ioLogik status events over the network. The log is stored on the Windows PC. You will need to set up your ioLogik server to send status events to the PC's IP address. The following events are monitored:

- cold start
- warm start

For each event, the following information is provided. The log can be sorted by any of these fields:

- Event type
- Event date and time
- ioLogik server source name
- Source IP
- Destination IP
- Host date and time
- Source model

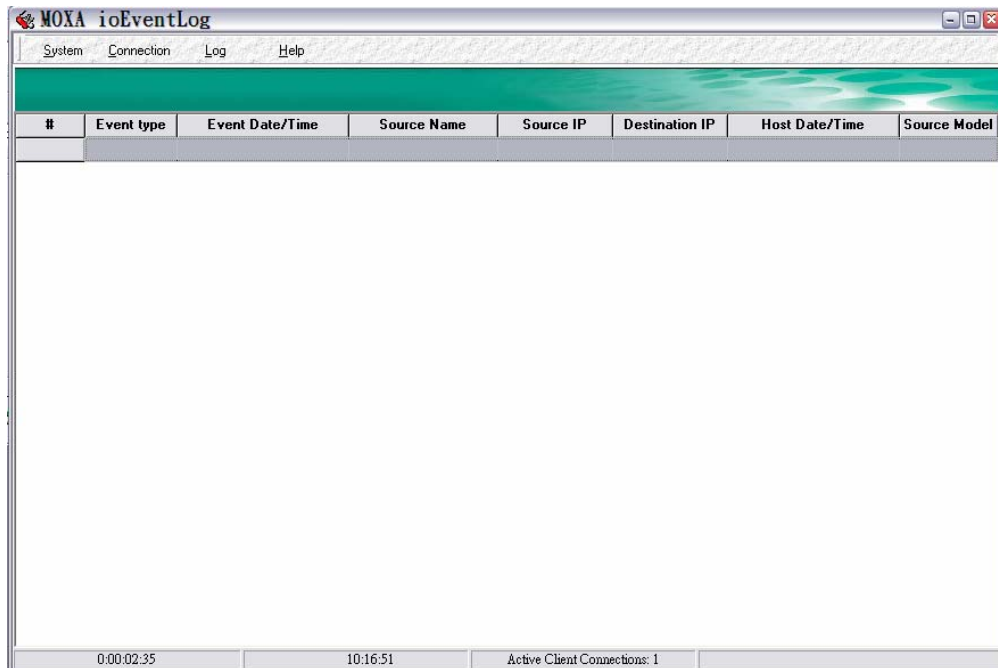

Configuration

In the System menu, select Settings to configure ioEventLog.

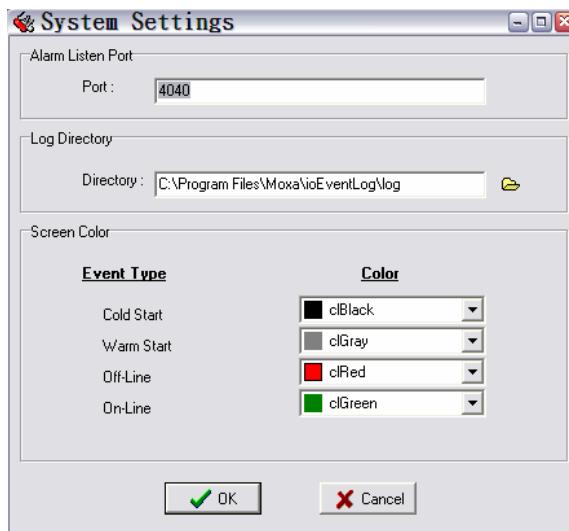

The Alarm Listen Port is the TCP port number that will be monitored for status events. You can modify this setting as necessary to receive signals through a firewall. It will need to match the settings for the ioLogik server that is being monitored.

The Log Directory is where the log files will be stored. The default directory is C:\Program Files\Moxa\ioEventLog\log. A separate log file is created for each day, with file names assigned automatically.

You can also select the color of each event type in the log.

Checking Connected Devices

You can see which I/O servers are already connected to ioEventLog by selecting Connected Device List from the Connection menu.



Opening Log Files

You can view previously saved logs by selecting Open from the Log menu. You will be prompted for the data that you wish to view.

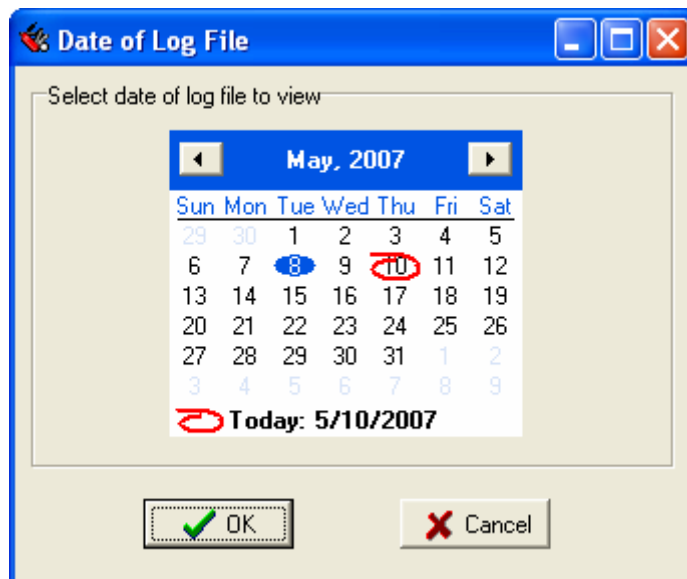

The logs for the selected day will be displayed.

Clearing the Log

If you wish to clear the log, you can select Clear from Log menu. This will clear all events for the current day. The cleared events will not be saved in that day's logs. After the logs are cleared, new events will be displayed and recorded as usual.

Using the Web Console

You may use the ioLogik E2210's built in web console to configure many options.

The following topics are covered:

- Introduction to the Web Console**
- Basic Settings**
- Network Settings**
 - General Settings
 - Ethernet Configuration
 - RS-485 Settings
- I/O Settings**
 - DI Channels
 - DO Channels
- System Management**
 - Accessible IP Settings
 - SNMP Agent
 - Network Connection
 - Firmware Update
 - Import System Config
 - Export System Config
- LCM**
- Change Password**
- Load Factory Default**
- Save/Restart**

Introduction to the Web Console

The ioLogik E2210 web console is a browser-based configuration utility. When the ioLogik E2210 is connected to your network, you may enter the server's IP address in your web browser to access the web console. Note that although most configuration options are available in the web console, some settings are only available through ioAdmin. Furthermore, the web console can be disabled under Web Access Settings in ioAdmin. If you are unable to access the web console, check the Web Access Settings in ioAdmin.

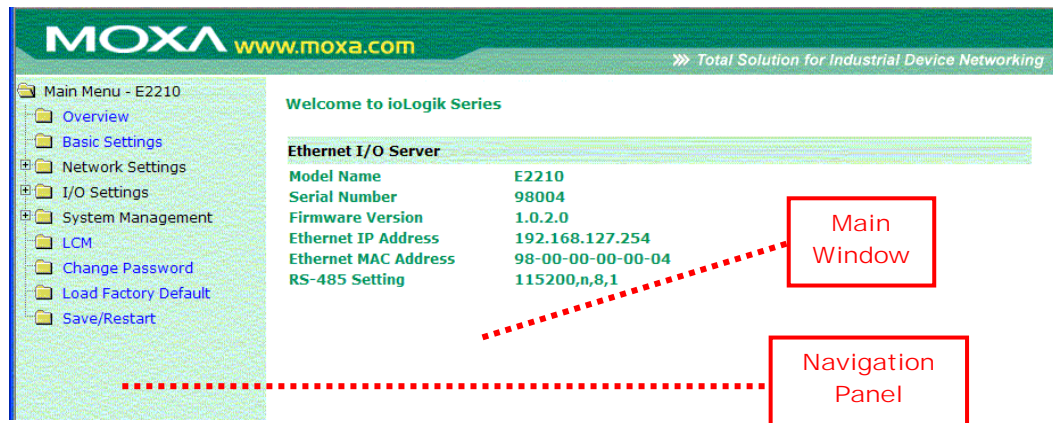

The left panel is the navigation panel and contains an expandable menu tree for navigating among the various settings and categories. When you click on a menu item in the navigation panel, the main window will display the corresponding options for that item. Configuration changes can then be made in the main window. For example, if you click on **Basic Settings** in the navigation panel, the main window will show a page of basic settings that you can configure.

You must click on the **Submit** button after making configuration changes. The **Submit** button will be located at the bottom of every page that has configurable settings. If you navigate to another page without clicking the **Submit** button, your changes will not be retained.

Submitted changes will not take effect until they are saved and the ioLogik E2210 is restarted! You may save and restart the server in one step by clicking on the **Save/Restart** button after you submit a change. If you need to make several changes before restarting, you may save your changes without restarting by selecting **Save/Restart** in the navigation panel. If you restart the ioLogik E2210 without saving your configuration, the ioLogik E2210 will discard all submitted changes.

Basic Settings

On the Basic Settings page, you may set the ioLogik E2210's system time or provide the IP address of a time server for time synchronization.

Network Settings

General Settings

On the General Settings page, you may assign a server name and location to assist you in differentiating between different I/O servers. You may also enable the Host Communication Watchdog and define the timeout value.

The Host Connection Watchdog activates Safe Status when the ioLogik E2210 loses its network connection for the specified amount of time. By default, the Watchdog is disabled. When the Watchdog is enabled and a timeout occurs, the ioLogik E2210 will enter Safe Status. You may use ioAdmin to configure how each DO channel responds in that channel's Safe Status settings.

To enable the Watchdog, check off **Enable connection watchdog**, set the timeout value, and restart the server. With Watchdog enabled, the ioLogik E2210 will enter Safe Status after there is disruption in communication that exceeds the time specified.

Ethernet Configuration

On the Ethernet Configuration page, you may set up a static or dynamic IP address for the ioLogik E2210, as well as the subnet mask and gateway address.

MOXA www.moxa.com »» Total Solution for Industrial Device Networking

Main Menu - E2210

- Overview
- Basic Settings
- Network Settings
 - General Settings
 - Ethernet Configurations**
 - RS-485 Settings
- I/O Settings
- System Management
 - LCM
 - Change Password
 - Load Factory Default
 - Save/Restart

Ethernet Configurations

Ethernet Parameters

IP Configuration:

IP Address:

Subnet Mask:

Gateway:

RS-485 Settings

On the RS-485 Settings page, you may view the serial communication parameters, but no configuration changes are allowed. The baudrate may only be configured by the physical dial on the back of the ioLogik E2210. This is a reserved function.

MOXA www.moxa.com »» Total Solution for Industrial Device Networking

Main Menu - E2210

- Overview
- Basic Settings
- Network Settings
 - General Settings
 - Ethernet Configurations
 - RS-485 Settings**
- I/O Settings
- System Management
 - LCM
 - Change Password
 - Load Factory Default
 - Save/Restart

RS-485 Settings

Serial Parameters

Unit ID: 0x01

Baud Rate: 115200

Data Bits: 8

Stop Bits: 1

Parity: None

I/O Settings

DI Channels

On the DI Channels page, you may view the status of each DI (digital input) channel.

DI Channel #	Mode	Status	Filter	Counter Trigger
[DI-00]	DI	Off	50.0 ms	--
[DI-01]	DI	Off	50.0 ms	--
[DI-02]	DI	Off	50.0 ms	--
[DI-03]	DI	Off	50.0 ms	--
[DI-04]	DI	Off	50.0 ms	--
[DI-05]	DI	Off	50.0 ms	--
[DI-06]	DI	Off	50.0 ms	--
[DI-07]	DI	Off	50.0 ms	--
[DI-08]	DI	Off	50.0 ms	--
[DI-09]	DI	Off	50.0 ms	--
[DI-10]	DI	Off	50.0 ms	--
[DI-11]	DI	Off	50.0 ms	--

You may also configure each channel's digital input mode and parameters by clicking on the channel. DI channels can operate in DI mode or Event Counter mode.



For DI mode, the maximum value of the filter is 65535.

For Event Counter mode, you may configure the low width and high width in multiples of 0.5 ms. The counter should be set to either **start**, or **stop**. If it is in **stop** mode, the counter can be activated by the Modbus command. Make sure that the Counter Filter is not set to 0, otherwise the counter will never be activated.

You may use the **Power On Setting** field to specify the channel's setting when the ioLogik E2210 is powered on, and the **Safe Status Setting** field to specify channel's setting when the ioLogik E2210 enters Safe Status. Note that Safe Status is controlled by the Host Connection Watchdog, which is disabled by default. If the Host Connection Watchdog is disabled, the ioLogik E2210 will never enter Safe Status and your Safe Status settings will have no effect.

DO Channels

On the DO Channels page, you may configure each DO (digital output) channel by clicking on the channel. DO Channels can operate in DO mode or Pulse Output mode. In DO mode, output is either on or off. In Pulse Output mode, a configurable square wave is generated.

DO Channel #	Mode	Status	Low Width	High Width
[DO-00]	DO	Off	--	--
[DO-01]	DO	Off	--	--
[DO-02]	DO	Off	--	--
[DO-03]	DO	Off	--	--
[DO-04]	DO	Off	--	--
[DO-05]	DO	Off	--	--
[DO-06]	DO	Off	--	--
[DO-07]	DO	Off	--	--

You may use the **Power On Setting** field to specify the channel's setting when the ioLogik E2210 is powered on, and the **Safe Status Setting** field to specify channel's setting when the ioLogik E2210 enters Safe Status. Note that Safe Status is controlled by the Host Connection Watchdog, which is disabled by default. If the Host Connection Watchdog is disabled, the ioLogik E2210 will never enter Safe Status and your Safe Status settings will have no effect.

System Management

Accessible IP Settings

On the Accessible IP Settings page, you may control network access to the ioLogik E2210 by allowing only specified IP addresses. When the accessible IP list is enabled, a host's IP address must be listed in order to have access to the ioLogik E2210.

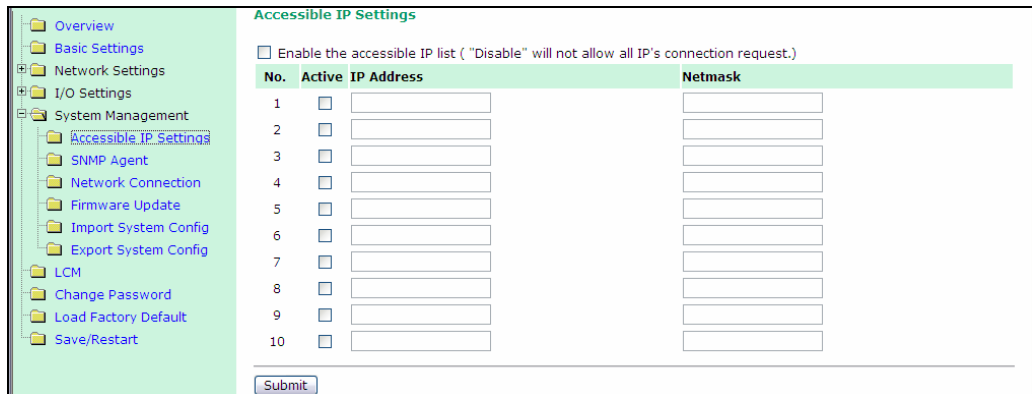

You may add a specific address or range of addresses by using a combination of IP address and netmask, as follows:

To allow access to a specific IP address

Enter the IP address in the corresponding field; enter **255.255.255.255** for the netmask.

To allow access to hosts on a specific subnet

For both the IP address and netmask, use **0** for the last digit (e.g., **192.168.1.0** and **255.255.255.0**).

To allow unrestricted access

Deselect the **Enable the accessible IP list** option.

Refer to the following table for additional configuration examples.

Allowed Hosts	IP address/Netmask
Any host	Disable
192.168.1.120	192.168.1.120 / 255.255.255.255
192.168.1.1 to 192.168.1.254	192.168.1.0 / 255.255.255.0
192.168.0.1 to 192.168.255.254	192.168.0.0 / 255.255.0.0
192.168.1.1 to 192.168.1.126	192.168.1.0 / 255.255.255.128
192.168.1.129 to 192.168.1.254	192.168.1.128 / 255.255.255.128

SNMP Agent

On the SNMP Agent page, you may enable SNMP and set the read and write community strings. The ioLogik E2210 provides SNMP v2 (Simple Network Management Protocol) to allow monitoring of network and I/O devices with SNMP Network Management software. It is useful in building automation and telecom applications.

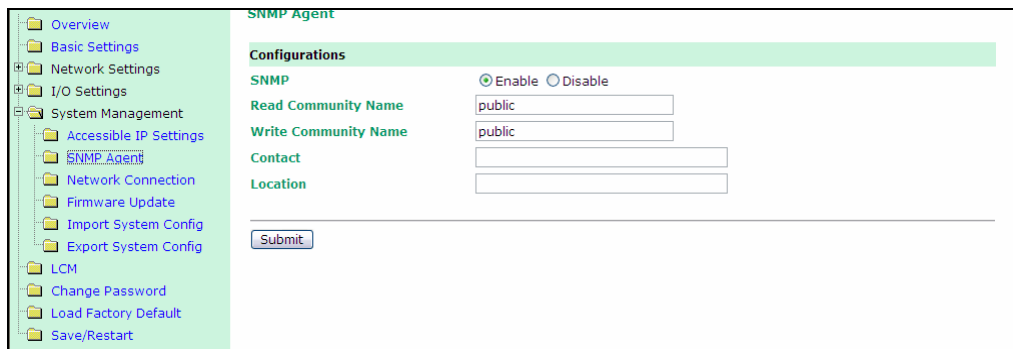

Network Connection

On the Network Connection page, you may view the TCP connections from other hosts. This may assist you in the management of your devices.

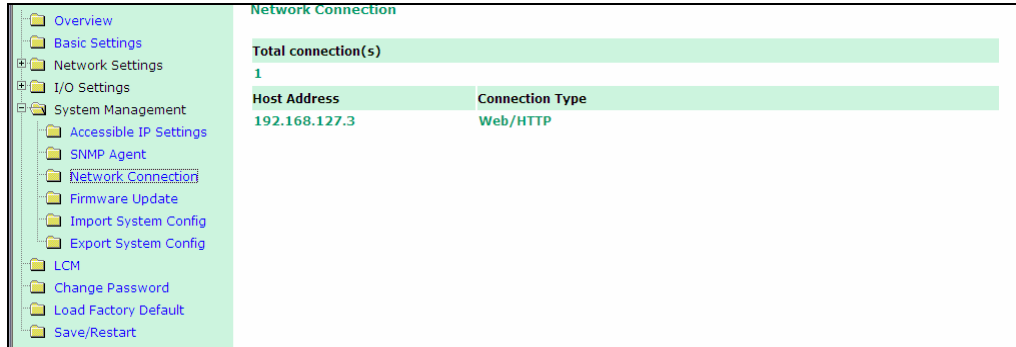

Firmware Update

On the Firmware Update page, you may load new or updated firmware onto the ioLogik.

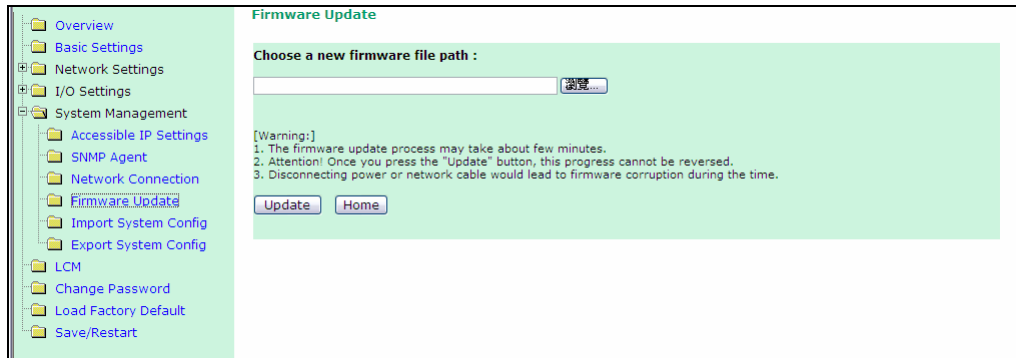

Import System Config

On the Import System Config page, you may import a configuration onto the ioLogik server. The configuration file can be generated by ioAdmin or through the web console. This function can be used to duplicate settings between ioLogik servers. You will be prompted for the location of the configuration file (i.e., "ik2210.txt").

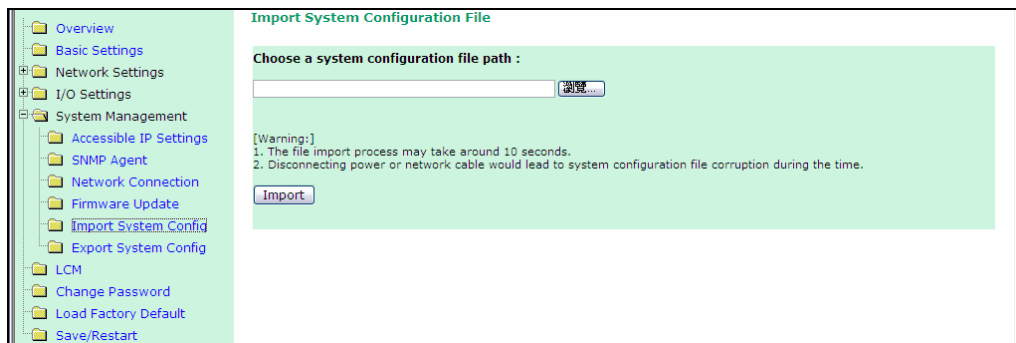

Export System Config

On the Export System Config page, you may save the ioLogik's configuration into a file for backup or import into another ioLogik server.

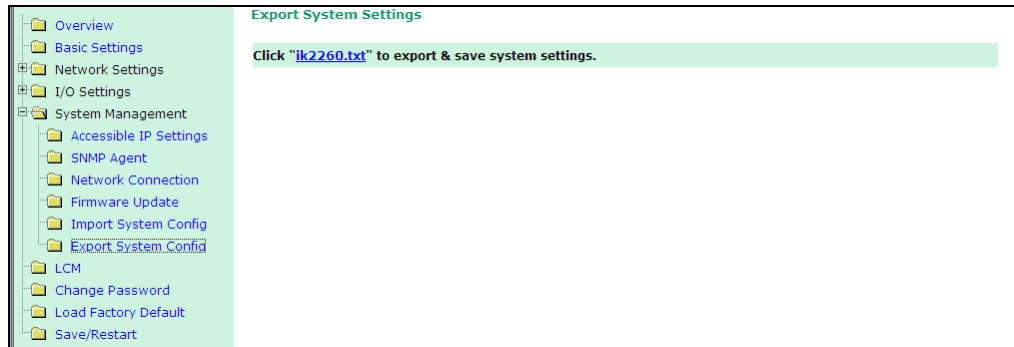

LCM

If you have installed the optional LCM, you may view the status and firmware details on the LCM page.



Change Password

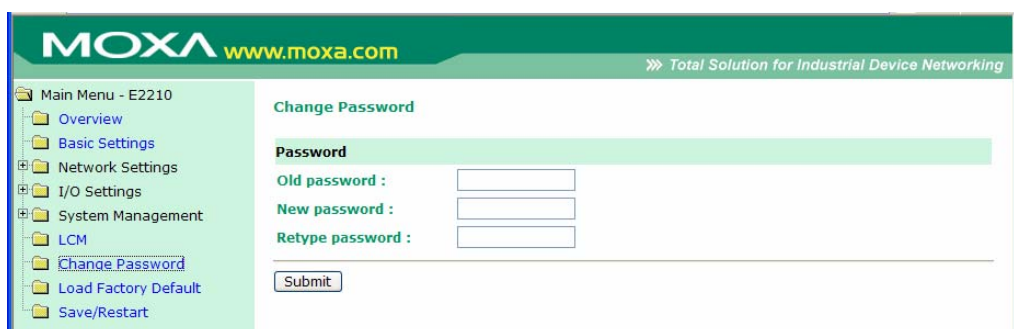

For all changes to the ioLogik E2210's password protection settings, you will first need to enter the old password. Leave this blank if you are setting up password protection for the first time. To set up a new password or change the existing password, enter your desired password under both **New password** and **Confirm password**. To remove password protection, leave the **New password** and **Confirm password** fields blank.

**ATTENTION**

If you forget the password, the **ONLY** way to configure the ioLogik E2210 is by using the reset button to load the factory defaults.

Before you set a password for the first time, it is a good idea to export the configuration to a file when you have finished setting up your ioLogik E2210. Your configuration can then be easily imported back into the ioLogik E2210 if you need to reset the ioLogik E2210 due to a forgotten password or for other reasons.

Load Factory Default

This function will reset all of the ioLogik E2210's settings to the factory default values. All previous settings including the console password will be lost.

Save/Restart

If you change the configuration, do not forget to reboot the system.

Click&Go Logic was developed by Moxa to provide an easy way to program your ioLogik E2210 for active I/O messaging. In the chapter, we will show you how Click&Go Logic works and how to use it to develop your active I/O messaging program.

The following topics are covered in this chapter:

- ❑ **Overview**
- ❑ **Features**
- ❑ **Click&Go Logic Basics**
 - Working with Rules
- ❑ **Defining Logic Rules**
 - IF Conditions
 - More Info on Repeat Interval vs. Edge Detection
 - THEN Actions
- ❑ **Defining Peer-to-Peer I/O Rules**
 - Configuring Input for Peer-to-Peer I/O
 - Configuring Output for Peer-to-Peer I/O
- ❑ **Working with Click&Go Rulesets**
 - Activating the Ruleset
 - Ruleset Management Bar
 - Ruleset Import/Export
- ❑ **Application Examples**
 - Local I/O Control
 - Active I/O Messages
 - Peer-to-Peer I/O
 - MXIO DLL for Active I/O Messages

Overview

The ioLogik E2210's Active Ethernet I/O system eliminates the need for host computers to continually poll I/O devices for status. Instead, the server itself is able to monitor the status of each I/O device and take the appropriate action when the I/O status satisfies a user-defined condition. For example, the ioLogik E2210 could be configured to send a TCP/UDP message only when the switch attached to DI(0) is turned on. This structure results in a much improved response time and a much reduced load on the host computer's CPU and on network bandwidth.

Click&Go Logic was developed by Moxa to easily and intuitively configure when and how I/O information is transmitted over the network. Using simple If – Then statements, you may set conditions that need to be satisfied and the actions that will be triggered. Up to three conditions and three actions can be combined in any one rule, and you may define up to 16 rules. SNMP traps and TCP/UDP messages may be configured for transmission to up to 10 computers simultaneously.

Click&Go can also be used to map an input channel on one ioLogik E2210 to an output channel on another ioLogik E2210, for direct peer-to-peer communication. Up to five different IP addresses can be entered as the output destination. This function can be described as peer-to-peer I/O, and provides a very flexible and easy way to extend I/O signals or set up remote on/off switches. It can be used, for example, to replace or extend the wiring of PLC or DCS systems over Ethernet.

Features

Click&Go Logic's key features are as follows:

- Easy local logic control using intuitive IF/THEN style construction
- Up to 16 user-defined rules
- Up to 3 I/O-based conditions and 3 DO or network actions per rule
- Choice of email, TCP, UDP, or SNMP Trap for active I/O messaging
- Customizable message content with dynamic fields for time, date, IP address, and more
- Up to 10 simultaneous IP destinations for TCP/UDP messaging
- Up to 5 simultaneous IP destinations for peer-to-peer I/O
- Configurable interval for time-triggered events

Click&Go Logic Basics

To use Click&Go Logic, open ioAdmin and log on as an administrator on the **Server Settings** tab. Once you are logged on, go to the **Click&Go Logic** tab. It should appear as below:

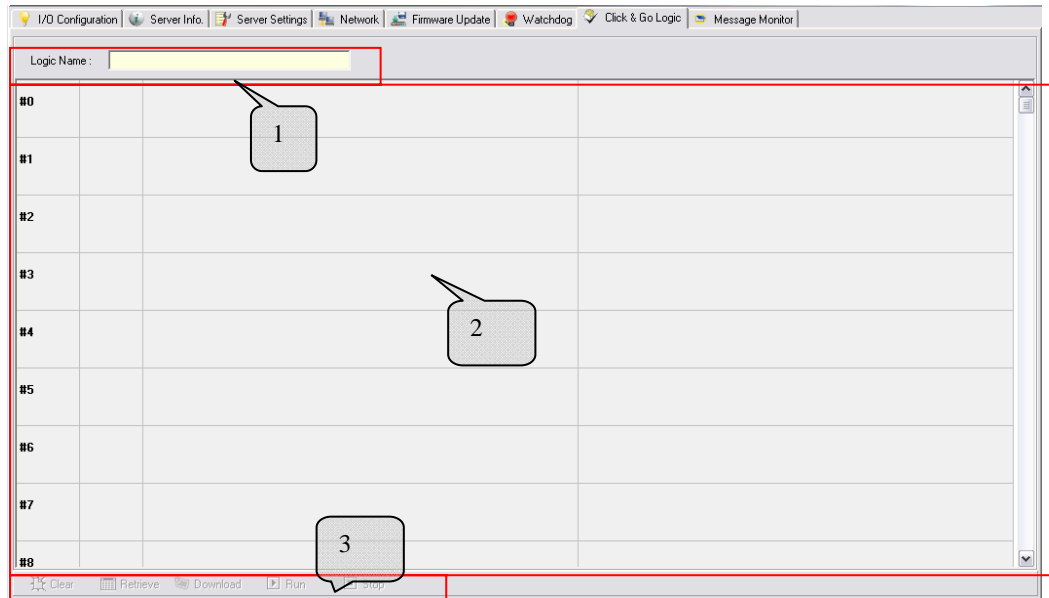

Click&Go Logic Tab	
1.	Logic Name: In this field, you may assign a name for the set of rules.
2.	Rules List: In this area, each rule's conditions, actions, and status are displayed.
3.	Ruleset Management Bar: In this area, you manage the ruleset

Working with Rules

Rules are the building blocks of your Active Ethernet I/O system. With rules, you define the exact trigger conditions for transmission of I/O information as well as the content and destination of that information. DO operation can also be automated through DI trigger conditions or mapped directly to a remote DI channel on another ioLogik E2210.

In the main screen, you will see a list of the rules in the current ruleset. Double click on a rule to open that rule's configuration window, or double click on an empty rule to start a new rule.

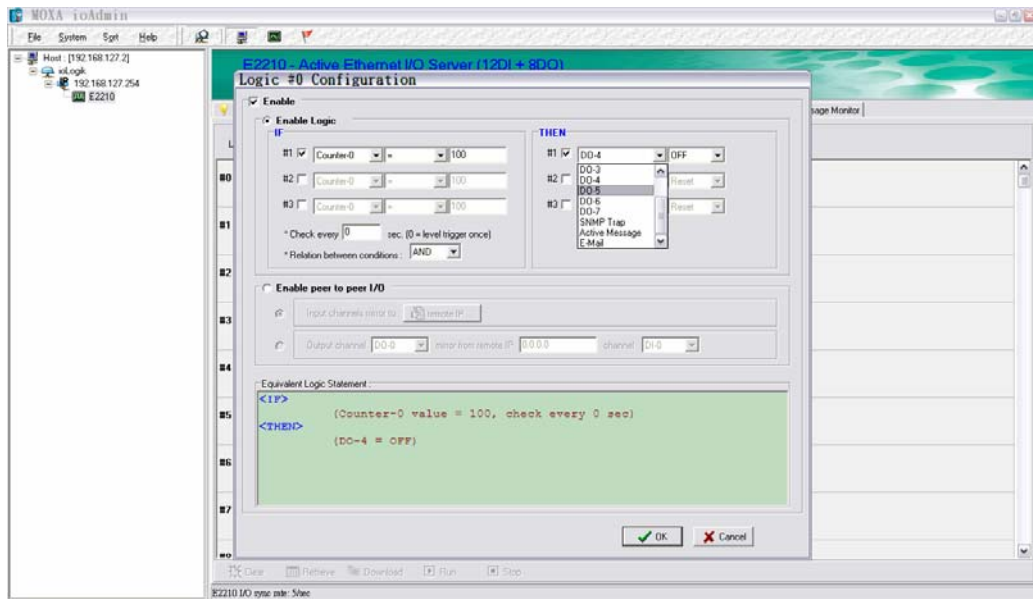

The configuration window is where the rule is defined. There are two types of rules that can be defined: Logic rules and peer-to-peer I/O rules. Logic rules are used for DI event-based triggers, whereas peer-to-peer I/O rules are used for mapping I/O channels between two ioLogik E2210 servers.

The **Equivalent Logic Statement** at the bottom shows a real-time text-based summary of the rule that you are defining. It can be a useful way to make sure that the rule is designed as you intended.



ATTENTION

When configuring input or output control or response values, **you must select the unit of measurement before entering a value**. If you select a unit of measurement after entering a value, the value will not be retained. Also, when an I/O channel is being used in a Click&Go Logic rule, the channel's range and units may not be modified.

Defining Logic Rules

IF Conditions

Under the **IF** column, you may set up to 3 sensor conditions that must be satisfied for the actions under the **THEN** column to take place. As soon as the IF conditions are satisfied, the specified THEN action is performed. For example, an alarm can be activated when a door is opened. Use the pull downs to specify the conditions and units of measurement (e.g. DI(0)=OFF). The available operators are =,<,>,<=,>=.

Edge detection can be used to refine the conditions. For example, the condition **DI(0)=OFF** is satisfied for as long as DI(0) remains off. The condition **DI(0)=ON to OFF**, however, is satisfied only at the instant that DI(0) turns off.

You may want an action to be repeated for as long as the conditions remain satisfied. For example, instead of turning on an alarm, you may wish to send an alert message every five minutes for as long as the door is open. You can set a repeating interval in the **Check every ___ sec** field. The THEN action will be repeated at the specified interval, as long as the set of IF conditions is satisfied. Note that if edge detection is used in the IF conditions, the **Check every ___ sec** field will be of no use,

because edge-detection conditions can only satisfied for an instant rather than over a sustained period of time. More information is provided below.

Under **Relation between condition**, select **AND** to specify that all conditions must satisfied for the action to take place; select **OR** to specify that any one of the conditions may be satisfied for the action to take place.

You may wish to set up a heartbeat status message or action that repeats at regular intervals as long as the I/O server is operational. In this case, you can set up a **Time Trigger** rule as the first IF condition. For example, you can set a 3600 second interval so that a TCP status message is sent every hour.

More Info on Repeat Interval vs. Edge Detection

The **Check every ___ sec** field is designed to allow THEN actions to be repeated when the specified conditions are sustained. However, if a condition is based on edge detection (i.e., **ON to OFF** or **OFF to ON**), it cannot be sustained, and the **Check every ___ sec** field will have no effect.

The following scenarios illustrate how edge detection affects the **Check every ___ sec** field. In each diagram, the statuses of three sensors are shown over a period of time, with a high signal corresponding to a "true" condition. The green shaded area shows the duration of time that the IF conditions have been met.

No Edge Detection		
In this scenario, the rule checks each sensor for "on" status, so edge detection is not involved. As long as the sensors remain on, the required conditions are satisfied, and the THEN actions will repeat at interval <i>N</i> .		
DI(0) = ON DI(1) = ON DI(2) = ON		
Relation between conditions	AND	OR
"IF" condition satisfied		
Request interval	"Check every <i>N</i> sec"	"Check every <i>N</i> sec"
"THEN" action triggered		

Edge Detection for All Conditions		
<p>In this scenario, the rule checks each sensor for a change from “off” to “on” status, meaning only edge detection conditions are used. As soon as a sensor changes from “off” to “on”, the condition is satisfied, but only for that instant. Right after that instant, the condition is no longer satisfied because it is no longer changing from “off” to “on”. The repeat interval will have no effect, since edge conditions cannot be sustained over a period of time.</p>		
DI(0) = OFF to ON DI(1) = OFF to ON DI(2) = OFF to ON		
Relation between conditions	AND	OR
“IF” condition satisfied		
Request interval	N/A	N/A
“THEN” action triggered		

Edge Detection for Two Conditions		
<p>In this scenario, the rule checks DI(0) and DI(1) for a change in status and DI(2) for status only. The repeat interval will not have an effect if the AND relationship is used, because the two edge conditions can never be sustained over a length of time. With the OR relationship, the IF conditions will be satisfied as long as DI(2) is “on”, and the THEN actions will be triggered over interval N.</p>		
DI(0) = OFF to ON DI(1) = OFF to ON DI(2) = ON		
Relation between conditions	AND	OR
“IF” condition satisfied		
Request interval	N/A	“Check every <i>N</i> sec”
“THEN” action triggered		

Edge Detection for One Condition		
<p>In this scenario, the rule checks DI(0) for a change in status and DI(1) and DI(2) for status only. The repeat interval will not have an effect if the AND relationship is used, because the edge condition for DI(0) can never be sustained over a length of time. With the OR relationship, the IF conditions will be satisfied as long as either DI(1) or DI(2) is “on”, and the THEN actions will be triggered over interval N.</p>		
<p>DI(0) = OFF to ON DI(1) = ON DI(2) = ON</p>		
Relation between conditions	AND	OR
“IF” condition satisfied		
Request interval	N/A	“Check every N sec”
“THEN” action triggered		

THEN Actions

Under the **THEN** column, you may set up to 3 actions that will be performed if the conditions under the **IF** column are satisfied. The 3 actions may be any combination of DI/O setting, SNMP trap, Active Message (by TCP/UDP), or E-mail. For SNMP trap, Active Message, and E-mail actions, use the following memo icon to additional parameters:

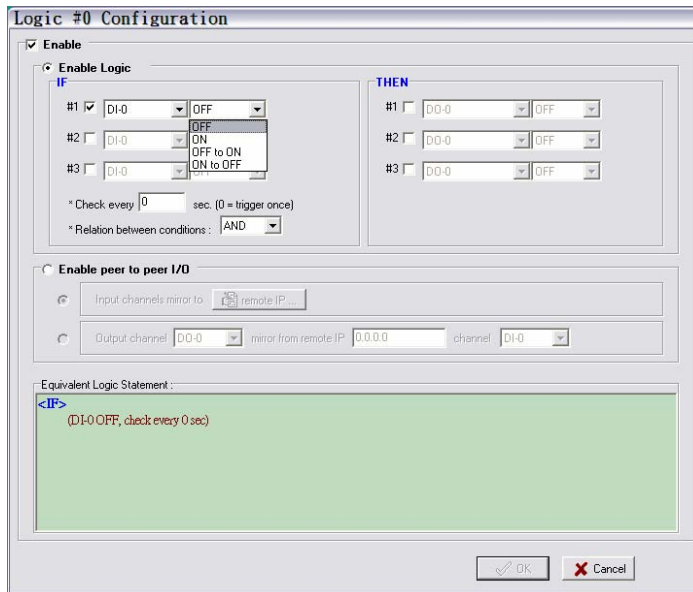

Summary of IF/THEN Parameters

IF Conditions	Operators	Remark
DI-x	ON, OFF, ON to OFF, OFF to ON	Depends on DI type
Counter-x	=,>,<,>=,<=,Change	Max value 4,294,967,295
Time Trigger (Condition #1 only)	N/A	Max value 4,294,967,295 for time interval

THEN Actions	Operators	Remark
Counter-x	Reset	Depends on DI type
DO-x	ON/OFF	Depends on DO type
Pulse Output-x	Start/Stop	Depends on DO type
SNMP Trap	1 to 20	Details below
Active Message	N/A	Details below
Email	N/A	Details below

Active Message

Select **Active Message** for active I/O messaging over TCP or UDP. Click the memo icon to configure the message and parameters. Note that TCP and UDP cannot be used at the same time within a ruleset – all rules must use the same protocol.

After clicking the memo icon, you may enter your desired message in the Message Content window. If necessary, dynamic fields such as time, date, IP address, and I/O status may be inserted in your message by clicking on the **Keyword Lookup** button. Up to 10 IP destinations for the message can be specified in the Message Receiver list. The default Message Port is 9000, and this can be modified as necessary to work with your firewall.

By default, messages are sent in ASCII, although ioAdmin can display the message in HEX in Message Monitor.

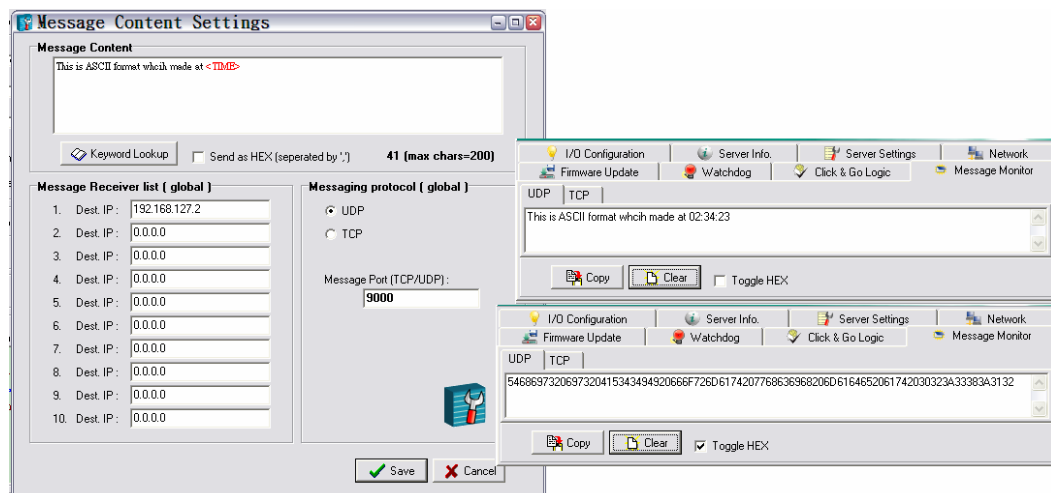

Messages may also be entered in HEX by selecting the “Send as HEX” checkbox. When sending a message in HEX, each HEX value must be delimited by commas. Certain control characters will only appear in the Message Monitor when “Toggle HEX” is selected, as in the following example.

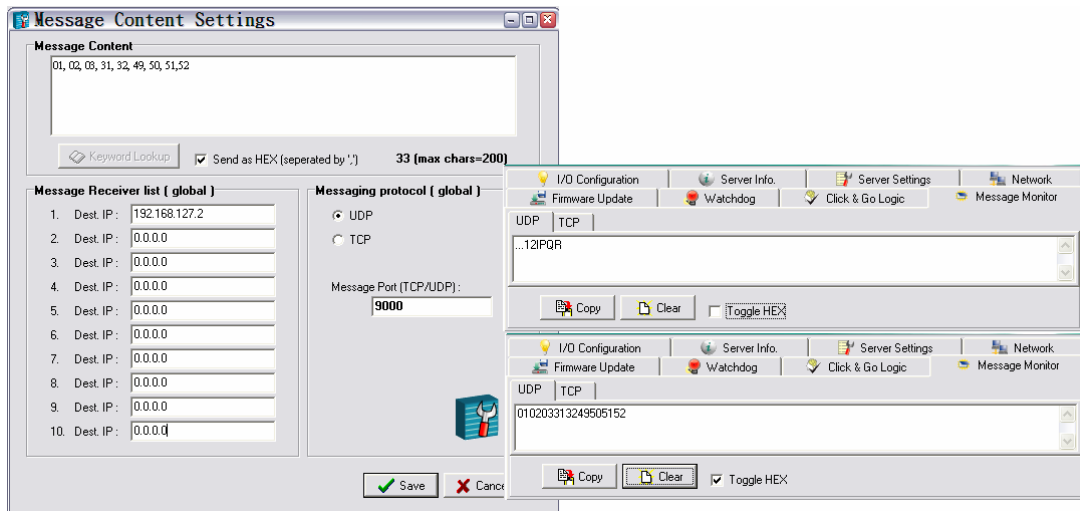

SNMP Trap

Select **SNMP trap** along with a trap number between 1 and 20. You may need to consult with your network administrator to determine how trap numbers will be used and defined in your network. Click the memo icon to specify up to 10 IP addresses to receive the SNMP trap. You can also bind the status of up to three I/O channels within each trap.

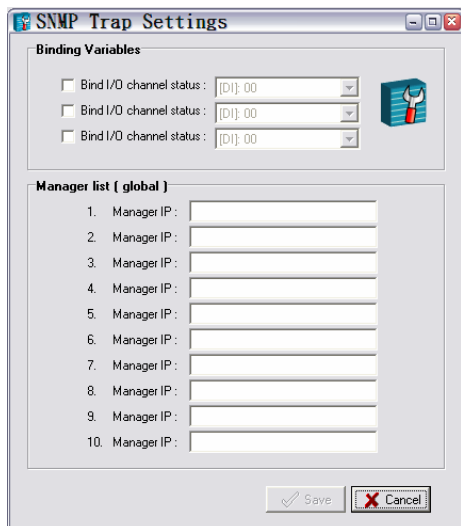
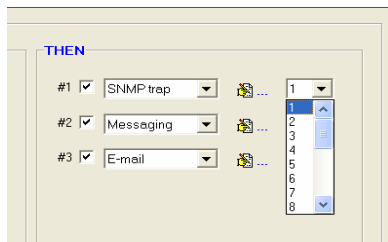

E-mail

Select **E-mail** to send a user-defined email to the specified addresses. Click the memo icon to enter the desired message and the intended recipients. Dynamic fields such as time, date, IP address, and I/O status may be inserted in your message by clicking on the **Keyword Lookup** button.

To add a recipient, you must first add the recipient's e-mail address to the **Available receivers list**. You may then use the finger icons to move e-mail addresses to and from the **Receivers list**. To edit an e-mail address, click on the memo icon. Note that the Available Receivers list will already contain a list of names if you provided the DNS server information in the Network Settings tab. Enter your own e-mail address in the **From Address** field.

Under **Mail Server Settings**, you must configure the IP address of the SMTP server with your username and password. Since the ioLogik E2210 supports DNS, you may enter the domain name of the SMTP server.

Defining Peer-to-Peer I/O Rules

A basic use of digital input and output is to connect a pushbutton to an LED. The pushbutton is the digital input, with on/off status controlled by a user, and the LED is the digital output, with on/off status controlled by the button. The peer-to-peer I/O function allows this operation to be mapped over Ethernet from a digital input on one ioLogik E2210 to the digital output on another ioLogik E2210. This allows a pushbutton in one location to have direct control of an LED in another room, building, or even city.

Peer-to-peer I/O can be used for simple one-to-one mapping, but also supports one-to-many and many-to-many mapping. A single digital input channel can be mapped to up to five remote digital output channels.

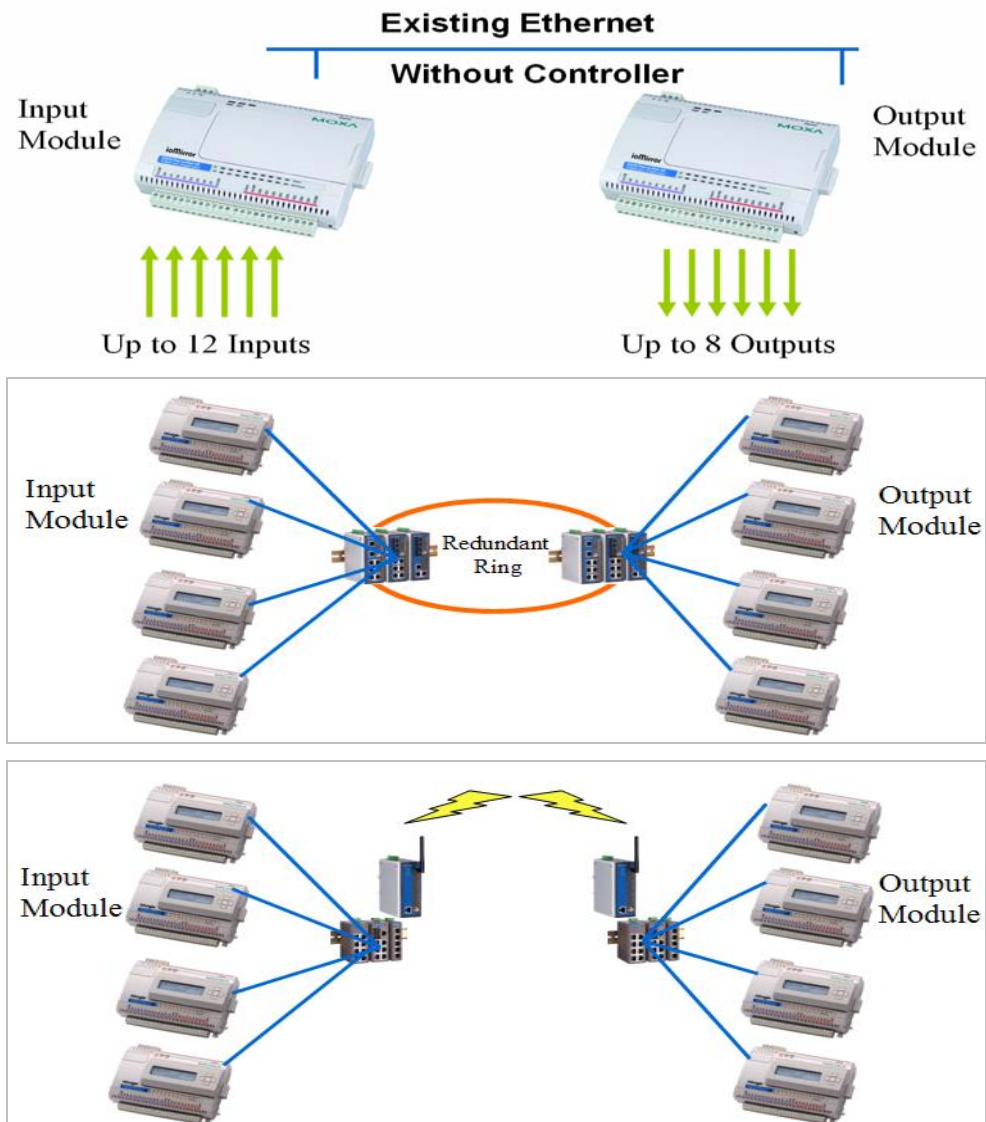

Peer-to-peer I/O is configured in two steps. On the input module, a rule is defined to send I/O data to one or more destination IP addresses. On the output module, a rule is defined for a specific output channel to mirror a specific channel on the input module.

Configuring Input for Peer-to-Peer I/O

Configuring the peer-to-peer I/O input module will use up one Click&Go rule on the ioLogik E2210 providing the input channels. In the Click&Go Logic tab, open a new rule's configuration window and enable peer-to-peer I/O. Select "Input channels mirror to", then click "remote IP..." and enter up to five IP addresses as destinations. Each IP address should belong to an ioLogik E2210 server that will provide output channels for the peer-to-peer I/O. You may repeat this process with additional peer-to-peer I/O rules if you wish to mirror input channels to more than five destinations. If all 16 rules are used for peer-to-peer I/O, a total of 80 destination IP addresses can be entered.

Make sure that the specific input channels that will be mirrored are set to DI mode, not Event Counter mode.

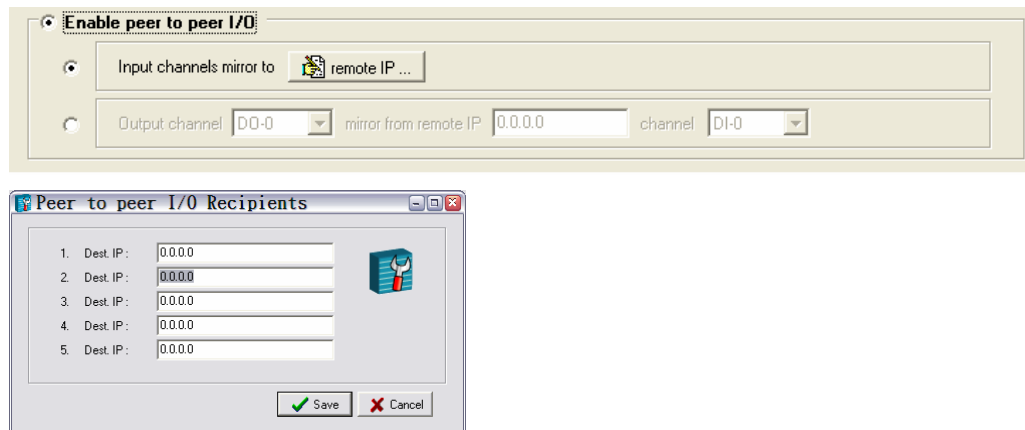

Note that you cannot configure the ioLogik E2210 as an input module and as an output module simultaneously within one rule. This may be done only by using at least two rules: one rule to configure input module operation and another rule to define output module operation.

Configuring Output for Peer-to-Peer I/O

Configuring the peer-to-peer I/O output module will use up one Click&Go rule for each output channel that mirrors a remote input channel. In the Click&Go tab, open a new rule's configuration window and enable peer-to-peer I/O. Select "Output channel" and provide the DO channel that will mirror the remote input channel, the IP address of the input module (i.e., the remote ioLogik E2210), and the DI channel on the input module that will be mirrored.

For example, DO-0 on the output module can be configured to mirror DI-0 on the input module. When DI-0 on the input module is on, DO-0 on the output module will turn on; when DI-0 on the input module is off, DO-0 on the output module will turn off.

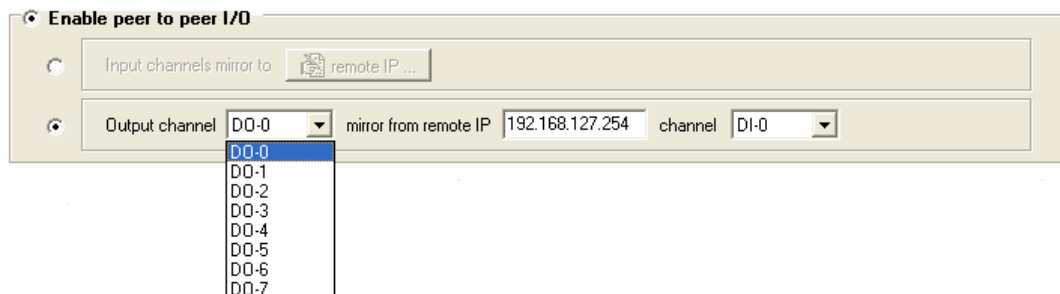

Make sure that the input module has been configured to mirror its input channels to this ioLogik E2210's IP address. Also, any output channels used for peer-to-peer I/O must be set to DO mode, not Pulse Output mode.

Once both the input and output sides have been configured, you may begin peer-to-peer I/O operation by activating the rulesets on both ioLogik E2210 servers and making sure they both have valid connections to the network.

If the ioLogik E2210 will be serving simultaneously as an input module and as an output module, you will need to use at least two rules: one rule to configure input module operation and one rule to for each output module channel.

Working with Click&Go Rulesets

Activating the Ruleset

A Click&Go Logic ruleset consists of all the rules that are defined for the I/O server. The Click&Go Logic tab lists all the rules in the current ruleset, which acts as the brain of your active I/O system. The rules in a ruleset work together to determine what I/O information is sent, who it is sent to, how it is sent, and under what I/O conditions it is sent. This simple but powerful tool is significantly more efficient with network and CPU resources than traditional blanket polling methods.

In order to operate as an Active Ethernet I/O server rather than a passive remote I/O server, the ioLogik E2210 will need to perform three steps after all rules in the ruleset have been defined:

1. The ruleset must first be downloaded from ioAdmin onto the ioLogik E2210. You may do so by clicking on **Download** in the Ruleset Management bar.
2. After the ruleset has been downloaded, you must restart the ioLogik E2210. You may do this by right clicking on the server name in the navigation panel in ioAdmin and selecting **Restart**. Do not use the reset button, as that will load all factory defaults and erase your ruleset from memory.
3. After the ioLogik E2210 has restarted, the ruleset must be activated for Active Ethernet I/O operation. First, you will need to log in as an administrator again in ioAdmin's Server Setting tab. Once you have logged in, go to the Click&Go Logic tab and click **Run** in the Ruleset Management bar. This will activate the ruleset and the ioLogik E2210 will begin working as an Active Ethernet I/O server.

When the ruleset has been activated, it will remain active even when the ioLogik E2210 is disconnected from the host computer or from the network. If the ioLogik E2210 is turned off, Active Ethernet I/O operation will resume when it is turned back on. This allows you to use the ioLogik E2210 for PC-independent automation.

Ruleset Management Bar

- **Clear:** The Clear command erases the ruleset in both ioAdmin and in the ioLogik E2210.
- **Retrieve:** The Retrieve command copies the ruleset from the ioLogik E2210 into ioAdmin.
- **Download:** The Download command copies the ruleset from ioAdmin onto the ioLogik E2210.
- **Run:** The Run command starts the active I/O messaging system using the ruleset that the ioLogik E2210 booted up with.
- **Stop:** The Stop command stops the active I/O messaging system.

Ruleset Import/Export

Although rulesets alone cannot be imported and exported, the entire system configuration including the current ruleset may be imported and exported. As you make changes to a ruleset, you may export the system configuration in order to save that ruleset.

Application Examples

Local I/O Control

In this scenario, we have two switches, one attached to DI(0) and one attached to DO(0). Very simply, we want DO(0) to automatically mirror DI(0)'s setting. Once the ruleset is downloaded onto the ioLogik E2210 and activated, the server handles all processing locally and there is no usage of network or host resources.

Rule 0: IF DI(0)=ON, THEN DO(0)=ON

Rule 1: IF DI(0)=OFF, THEN DO(0)=OFF.

1. In ioAdmin, make sure that you have logged in on the **Server Settings** tab. Go to the **Click&Go Logic** tab.
2. Double click on **#0** in the **Rules List**. The rule configuration window will appear.
3. Make sure that **Enable** in the upper left hand corner is checked.
4. Select **Enable Logic**.
5. Select **DI(0)** as your condition in the first **IF field**, and set its value to **ON**.
6. Select **DO(0)** as your action in the first **THEN field**, and set its value **ON**.
7. Click on **OK**.
8. Double click on **#1** in the **Rules List**.
9. Make sure that **Enable** in the upper left hand corner is checked.
10. Select **Enable Logic**.
11. Select **DI(0)** as your condition in the first **IF field**, and set its value to **OFF**.
12. Select **DO(0)** as your action in the first **THEN field**, and set its value **OFF**.
13. Click on **OK**.
14. Click on **Download** on the **Ruleset Management Bar**.
15. Select **Yes** when asked to restart and wait until the server has restarted and is back on-line.
16. Log in on the **Server Settings** tab, then go to the **Click&Go Logic** tab.
17. Click on **Run** on the **Ruleset Management Bar**. The RDY LED will be flashing green, showing that the server is now operating as an Active Ethernet I/O server, using the ruleset that was just defined.

Active I/O Messages

In this scenario, we have a switch attached to DI(0). We want the server to send a TCP message that indicates the exact time that the switch is turned on.

Rule 0: IF DI(0)=ON, THEN send Active Message

1. In ioAdmin, make sure that you have logged in on the **Server Settings** tab. Go to the **Click&Go Logic** tab.
2. Double click on #0 in the **Rules List**. The rule configuration window will appear.
3. Make sure that **Enable** in the upper left hand corner is checked.
4. Select **Enable Logic**.
5. Select **DI(0)** as your condition in the first **IF field**, and set its value to **ON**.
6. Select **Active Message** as your action in the first **THEN field**.
7. Click the memo button. The Message parameters window will appear.
8. Click on **Keyword Lookup**. In the Variable List that pops up, click on **<Server_time>**.
9. Click on **Save**.
10. Click on **Download** on the **Ruleset Management Bar**.
11. Select **Yes** when asked to restart and wait until the server has restarted and is back on-line.
12. Log in on the **Server Settings** tab, then go to the **Click&Go Logic** tab.
13. Click on **Run** on the **Ruleset Management Bar**. The RDY LED will be flashing green, showing that the server is now operating as an Active Ethernet I/O server, using the ruleset that was just defined.

Peer-to-Peer I/O

In this scenario, we are using peer-to-peer I/O to replace 2 km of I/O wiring between a control panel and a water tank using peer-to-peer I/O.

Before:

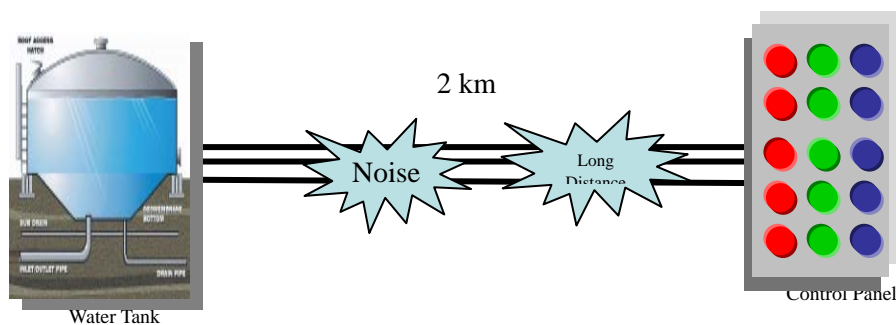

After:

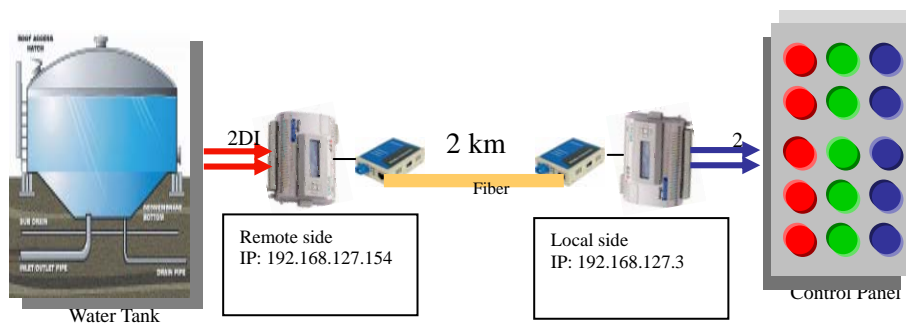

At 192.168.127.154

Rule 0: Send I/O status to 192.168.127.3

1. In ioAdmin, make sure that you have searched for and selected the correct ioLogik E2210 server, at IP address 192.168.127.154. Also, make sure you are logged in on the **Server Settings** tab. Go to the **Click&Go Logic** tab.
2. Double click on **#0** in the **Rules List**. The rule configuration window will appear.
3. Make sure that **Enable** in the upper left hand corner is checked.
4. Select **Enable peer-to-peer I/O**
5. Select **Input channels mirror to** and click **remote IP...**
6. In the **1. Dest. IP:** field, enter **192.168.127.3** and click **OK** to save this setting.
7. Click **OK** to finish configuring the rule.
8. Click on **Download** on the **Ruleset Management Bar**.
9. Select **Yes** when asked to restart and wait until the server has restarted and is back on-line.
10. Log in on the **Server Settings** tab, then go to the **Click&Go Logic** tab.
11. Click on **Run** on the **Ruleset Management Bar**. The RDY LED will be flashing green, showing that the server is now operating as an Active Ethernet I/O server, using the ruleset that was just defined.

At 192.168.127.3

Rule 0: DI(0) at 192.168.127.154 mapped to DO(0)

Rule 1: DI(1) at 192.168.127.154 mapped to DO(1)

1. In ioAdmin, make sure that you have searched for and selected the correct ioLogik E2210 server, at IP address 192.168.127.3. Also, make sure you are logged in on the **Server Settings** tab. Go to the **Click&Go Logic** tab.
2. Double click on **#0** in the **Rules List**. The rule configuration window will appear.
3. Make sure that **Enable** in the upper left hand corner is checked.
4. Select **Enable peer-to-peer I/O**
5. Select **Output channel**, then select **DO-0** for the first field, enter **192.168.127.154** for the second field, and select **DI-0** for the third field.
6. Click **OK** to finish configuring the rule.
7. Double click on **#1** in the **Rules List**. The rule configuration window will appear.
8. Make sure that **Enable** in the upper left hand corner is checked.
9. Select **Enable peer-to-peer I/O**
10. Select **Output channel**, then select **DO-1** for the first field, enter **192.168.127.154** for the second field, and select **DI-1** for the third field.
11. Click **OK** to finish configuring the rule.
12. Click on **Download** on the **Ruleset Management Bar**.
13. Select **Yes** when asked to restart and wait until the server has restarted and is back on-line.

14. Log in on the **Server Settings** tab, then go to the **Click&Go Logic** tab.
15. Click on **Run** on the **Ruleset Management Bar**. The RDY LED will be flashing green, showing that the server is now operating as an Active Ethernet I/O server, using the ruleset that was just defined.

Sensors at the water tank will connect to digital input channels at 192.168.127.154, and the digital output channels at 192.168.127.3 will connect to the control panel. As long as both ioLogik E2210's are on and connected to the network, the status of digital output channels 0 and 1 at 192.168.127.3 will be a "mirror" of input channels 0 and 1 at 192.168.127.154. Status will be updated once every second.

MXIO DLL for Active I/O Messages

This is an example of a Visual C application that receives active I/O messages using the MXIO DLL library. We do not recommend using Visual Basic, because Visual Basic does not support multi-threading environments.

```

/*****
/*
/* Example program : Message.cpp
/*
/* Description:
/* 1. Receive active message from ioLogik 2000 ethernet series.
/* 2. The message transmission can use TCP protocol or UDP protocol.
/*
/* List of MXIO Functions used in this example:
/* MXEIO_Init, MXEIO_Exit, Message2K_Start, Message2K_Stop
/*
/*****
#include <stdio.h>
#include <stdlib.h>
#include "..\..\..\..\..\include\c\Mxio.h"

void CALLBACK getTcpMessage( BYTE data[], WORD wSize ); //TCP call back function
void CALLBACK getUdpMessage( BYTE data[], WORD wSize ); //UDP call back function

void CheckErr( int iRet, char * szFunctionName ); //check function execution result

int main()
{
    /*******
    // Initiate socket and create connection
    /*******
    int iRet; //stored return code

    //Initiate the socket to use
    iRet = MXEIO_Init();

    CheckErr( iRet, "MXEIO_Init" );

    printf("Initiate the socket succeeded.\n");

    /*******
    // start TCP & UDP active message
    /*******
    iRet = Message2K_Start( PROTOCOL_TCP, //start TCP message
                          9000, //TCP port number
                          getTcpMessage ); //call back function

    CheckErr( iRet, "Message2K_Start" );

    printf("Start to receive active TCP message.\n");

    iRet = Message2K_Start( PROTOCOL_UDP, //start UDP message
                          9000, //UDP port number
                          getUdpMessage ); //call back function

    CheckErr( iRet, "Message2K_Start" );

    printf("Start to receive active UDP message.\n");

```



```

        ::Sleep( 5000 );
        Message2K_Stop( PROTOCOL_TCP );      //stop TCP message
        printf("Stop to receive active TCP message.\n");
        Message2K_Stop( PROTOCOL_UDP );      //stop UDP message
        printf("Stop to receive active UDP message.\n");

        //*****
        // disconnect and terminate socket
        //*****

        //To terminates use of the socket
        MXEIO_Exit();

        printf("Terminate the socket succeeded.\n");

        return 0;
    }

void CALLBACK getTcpMessage( BYTE data[], WORD wSize )
{
    data[wSize] = 0;
    printf( "TCP Message : %s\n", data );
}

void CALLBACK getUdpMessage( BYTE data[], WORD wSize )
{
    data[wSize] = 0;
    printf( "UDP Message : %s\n", data );
}

// After each MXIO function call, the application checks whether the call succeeded.
// If the call failed, this procedure prints an error message and exits.
void CheckErr( int iRet, char * szFunctionName )
{
    if( iRet != MXIO_OK )
    {
        char * szErrMsg;

        switch( iRet )
        {
            case ILLEGAL_FUNCTION:
                szErrMsg = "ILLEGAL_FUNCTION";
                break;
            case ILLEGAL_DATA_ADDRESS:
                szErrMsg = "ILLEGAL_DATA_ADDRESS";
                break;
            case ILLEGAL_DATA_VALUE:
                szErrMsg = "ILLEGAL_DATA_VALUE";
                break;
            case SLAVE_DEVICE_FAILURE:
                szErrMsg = "SLAVE_DEVICE_FAILURE";
                break;
            case SLAVE_DEVICE_BUSY:
                szErrMsg = "SLAVE_DEVICE_BUSY";
                break;
            case EIO_TIME_OUT:
                szErrMsg = "EIO_TIME_OUT";
                break;
            case EIO_INIT_SOCKETS_FAIL:
                szErrMsg = "EIO_INIT_SOCKETS_FAIL";
                break;
            case EIO_CREATING_SOCKET_ERROR:
                szErrMsg = "EIO_CREATING_SOCKET_ERROR";
                break;
            case EIO_RESPONSE_BAD:
                szErrMsg = "EIO_RESPONSE_BAD";
                break;
            case EIO_SOCKET_DISCONNECT:
                szErrMsg = "EIO_SOCKET_DISCONNECT";
                break;
            case PROTOCOL_TYPE_ERROR:
                szErrMsg = "PROTOCOL_TYPE_ERROR";
                break;
        }
    }
}

```

```

        case SIO_OPEN_FAIL:
            szErrMsg = "SIO_OPEN_FAIL";
            break;
        case SIO_TIME_OUT:
            szErrMsg = "SIO_TIME_OUT";
            break;
        case SIO_CLOSE_FAIL:
            szErrMsg = "SIO_CLOSE_FAIL";
            break;
        case SIO_PURGE_COMM_FAIL:
            szErrMsg = "SIO_PURGE_COMM_FAIL";
            break;
        case SIO_FLUSH_FILE_BUFFERS_FAIL:
            szErrMsg = "SIO_FLUSH_FILE_BUFFERS_FAIL";
            break;
        case SIO_GET_COMM_STATE_FAIL:
            szErrMsg = "SIO_GET_COMM_STATE_FAIL";
            break;
        case SIO_SET_COMM_STATE_FAIL:
            szErrMsg = "SIO_SET_COMM_STATE_FAIL";
            break;
        case SIO_SETUP_COMM_FAIL:
            szErrMsg = "SIO_SETUP_COMM_FAIL";
            break;
        case SIO_SET_COMM_TIME_OUT_FAIL:
            szErrMsg = "SIO_SET_COMM_TIME_OUT_FAIL";
            break;
        case SIO_CLEAR_COMM_FAIL:
            szErrMsg = "SIO_CLEAR_COMM_FAIL";
            break;
        case SIO_RESPONSE_BAD:
            szErrMsg = "SIO_RESPONSE_BAD";
            break;
        case SIO_TRANSMISSION_MODE_ERROR:
            szErrMsg = "SIO_TRANSMISSION_MODE_ERROR";
            break;
        case PRODUCT_NOT_SUPPORT:
            szErrMsg = "PRODUCT_NOT_SUPPORT";
            break;
        case HANDLE_ERROR:
            szErrMsg = "HANDLE_ERROR";
            break;
        case SLOT_OUT_OF_RANGE:
            szErrMsg = "SLOT_OUT_OF_RANGE";
            break;
        case CHANNEL_OUT_OF_RANGE:
            szErrMsg = "CHANNEL_OUT_OF_RANGE";
            break;
        case COIL_TYPE_ERROR:
            szErrMsg = "COIL_TYPE_ERROR";
            break;
        case REGISTER_TYPE_ERROR:
            szErrMsg = "REGISTER_TYPE_ERROR";
            break;
        case FUNCTION_NOT_SUPPORT:
            szErrMsg = "FUNCTION_NOT_SUPPORT";
            break;
        case OUTPUT_VALUE_OUT_OF_RANGE:
            szErrMsg = "OUTPUT_VALUE_OUT_OF_RANGE";
            break;
        case INPUT_VALUE_OUT_OF_RANGE:
            szErrMsg = "INPUT_VALUE_OUT_OF_RANGE";
            break;
    }

    printf( "Function \"%s\" execution Fail. Error Message : %s\n",
szFunctionName, szErrMsg );

    //To terminates use of the socket
    MXEIO_Exit();

    exit(1);
}
}

```

A

Liquid Crystal Display Module (LCM)

The ioLogik E2210 supports an optional detachable Liquid Crystal Display Module (LCM) for easier field maintenance. The LCM is hot-pluggable and can be used to configure the network settings or display other settings. When plugged in, the LCM displays the ioLogik E2210 “home page,” and pressing any button takes you into the settings and configuration.

LCM Controls

The up and down buttons navigate between the current options. The right and left buttons enter and exit the submenus. The center button is used when modifying settings or restarting the server.

Button	Function
Up	go to the previous item
Down	go to the next item
Left	exit the current submenu and return to the previous menu (go up one level)
Right	enter the selected submenu (go down one level)
Center	enter/exit editing mode

An “e” in the upper right hand corner of the display indicates that the parameter can be modified. Press the center button on the LCM to modify that parameter’s settings.

LCM Options

Display	Explanation / Actions
<ioLogik E2210>	This is the default “home page” showing the IP address. Press the down button to view the submenus.
<ioLogik E2210> server	Enter this submenu to display information about the specific server you are viewing: <ul style="list-style-type: none">● serial number● name● location● E2210 f/w ver● lcm f/w ver● model name

Display	Explanation / Actions
<ioLogik E2210> network	Enter this submenu to display information and settings for the network: <ul style="list-style-type: none"> ● Ethernet link ● MAC address ● IP mode ● IP address ● netmask ● gateway ● DNS server-1 ● DNS server-2
<ioLogik E2210> click&go	Enter this submenu to display information about the ruleset being used by the active I/O system. <ul style="list-style-type: none"> ● name ● status
<ioLogik E2210> serial port	Enter this submenu to display the RS-485 cascade port settings.
<ioLogik E2210> i/o setting	Enter this submenu to access I/O channel status. Here are examples of settings that you might see: <ul style="list-style-type: none"> ● DI-00 [di]=off ● DO-00 [pulse]=stop Press up or down to navigate through the different I/O channels without having to go back to the previous menu.
<ioLogik E2210> console	Enter this submenu to see if the web console is enabled or disabled.
<ioLogik E2210> ping	Select this option to enter an IP address to ping. If you get a "timeout" error, it indicates that the E2210 cannot reach that IP address. Otherwise, the display will show the response time.
<ioLogik E2210> save/restart	Enter this submenu to display the restart now submenu. Enter the restart now submenu to display the restart option. Press the center button to modify this option, then select enable to save changes and reboot the I/O server. The disable option has no effect.

**WARNING**

Any configuration changes that are made through the LCM will not take effect until the ioLogik E2210 is restarted.

B

Modbus/TCP Address Mappings

E2210 Modbus Mapping

0xxxx Read/Write Coils (Functions 1, 5, 15)

Reference	Address	Data Type	Description
00001	0x0000	1 bit	CH0 DO Value 0: Off 1: On
00002	0x0001	1 bit	CH1 DO Value 0: Off 1: On
00003	0x0002	1 bit	CH2 DO Value 0: Off 1: On
00004	0x0003	1 bit	CH3 DO Value 0: Off 1: On
00005	0x0004	1 bit	CH4 DO Value 0: Off 1: On
00006	0x0005	1 bit	CH5 DO Value 0: Off 1: On
00007	0x0006	1 bit	CH6 DO Value 0: Off 1: On
00008	0x0007	1 bit	CH7 DO Value 0: Off 1: On
00009	0x0008	1 bit	CH0 DO Power On Value 0: Off 1: On
00010	0x0009	1 bit	CH1 DO Power On Value 0: Off 1: On
00011	0x000A	1 bit	CH2 DO Power On Value 0: Off 1: On
00012	0x000B	1 bit	CH3 DO Power On Value 0: Off 1: On
00013	0x000C	1 bit	CH4 DO Power On Value 0: Off 1: On
00014	0x000D	1 bit	CH5 DO Power On Value 0: Off 1: On
00015	0x000E	1 bit	CH6 DO Power On Value 0: Off 1: On
00016	0x000F	1 bit	CH7 DO Power On Value 0: Off 1: On
00017	0x0010	1 bit	CH0 DO Safe Value 0: Off 1: On
00018	0x0011	1 bit	CH1 DO Safe Value 0: Off 1: On
00019	0x0012	1 bit	CH2 DO Safe Value 0: Off 1: On
00020	0x0013	1 bit	CH3 DO Safe Value 0: Off 1: On
00021	0x0014	1 bit	CH4 DO Safe Value 0: Off 1: On
00022	0x0015	1 bit	CH5 DO Safe Value 0: Off 1: On
00023	0x0016	1 bit	CH6 DO Safe Value 0: Off 1: On
00024	0x0017	1 bit	CH7 DO Safe Value 0: Off 1: On
00025	0x0018	1 bit	CH0 DO Pulse Operate Status 0: Off 1: On
00026	0x0019	1 bit	CH1 DO Pulse Operate Status 0: Off 1: On
00027	0x001A	1 bit	CH2 DO Pulse Operate Status 0: Off 1: On
00028	0x001B	1 bit	CH3 DO Pulse Operate Status 0: Off 1: On
00029	0x001C	1 bit	CH4 DO Pulse Operate Status 0: Off 1: On
00030	0x001D	1 bit	CH5 DO Pulse Operate Status 0: Off 1: On
00031	0x001E	1 bit	CH6 DO Pulse Operate Status 0: Off 1: On
00032	0x001F	1 bit	CH7 DO Pulse Operate Status 0: Off 1: On
00033	0x0020	1 bit	CH0 DI Pulse Operate Status 0: Off 1: On
00034	0x0021	1 bit	CH1 DI Pulse Operate Status 0: Off 1: On

00035	0x0022	1 bit	CH2 DI Pulse Operate Status 0: Off 1: On
00036	0x0023	1 bit	CH3 DI Pulse Operate Status 0: Off 1: On
00037	0x0024	1 bit	CH4 DI Pulse Operate Status 0: Off 1: On
00038	0x0025	1 bit	CH5 DI Pulse Operate Status 0: Off 1: On
00039	0x0026	1 bit	CH6 DI Pulse Operate Status 0: Off 1: On
00040	0x0027	1 bit	CH7 DI Pulse Operate Status 0: Off 1: On
00041	0x0028	1 bit	CH8 DI Pulse Operate Status 0: Off 1: On
00042	0x0029	1 bit	CH9 DI Pulse Operate Status 0: Off 1: On
00043	0x002A	1 bit	CH10 DI Pulse Operate Status 0: Off 1: On
00044	0x002B	1 bit	CH11 DI Pulse Operate Status 0: Off 1: On
00045	0x002C	1 bit	CH0 DI Clear Count Value read always :0 Write: 1 : Clear counter value 0 : return Illegal Data Value
00046	0x002D	1 bit	CH1 DI Clear Count Value read always :0 Write: 1 : Clear counter value 0 : return Illegal Data Value
00047	0x002E	1 bit	CH2 DI Clear Count Value read always :0 Write: 1 : Clear counter value 0 : return Illegal Data Value
00048	0x002F	1 bit	CH3 DI Clear Count Value read always :0 Write: 1 : Clear counter value 0 : return Illegal Data Value
00049	0x0030	1 bit	CH4 DI Clear Count Value read always :0 Write: 1 : Clear counter value 0 : return Illegal Data Value
00050	0x0031	1 bit	CH5 DI Clear Count Value read always :0 Write: 1 : Clear counter value 0 : return Illegal Data Value
00051	0x0032	1 bit	CH6 DI Clear Count Value read always :0 Write: 1 : Clear counter value 0 : return Illegal Data Value
00052	0x0033	1 bit	CH7 DI Clear Count Value read always :0 Write: 1 : Clear counter value 0 : return Illegal Data Value
00053	0x0034	1 bit	CH8 DI Clear Count Value read always :0 Write: 1 : Clear counter value 0 : return Illegal Data Value
00054	0x0035	1 bit	CH9 DI Clear Count Value read always :0 Write: 1 : Clear counter value 0 : return Illegal Data Value
00055	0x0036	1 bit	CH10 DI Clear Count Value read always :0 Write: 1 : Clear counter value 0 : return Illegal Data Value
00056	0x0037	1 bit	CH11 DI Clear Count Value read always :0 Write: 1 : Clear counter value 0 : return Illegal Data Value
00057	0x0038	1 bit	CH0 DI OverFlow Status Read : 0 : Normal 1 : Overflow Write : 0 : clear overflow status 1 : return Illegal Data Value

00076	0x004B	1 bit	CH7 DI Count Trigger
00077	0x004C	1 bit	CH8 DI Count Trigger
00078	0x004D	1 bit	CH9 DI Count Trigger
00079	0x004E	1 bit	CH10 DI Count Trigger
00070	0x004F	1 bit	CH11 DI Count Trigger

1xxxx Read Only Coils (Function 2)

Reference	Address	Data Type	Description
10001	0x0000	1 bit	CH0 DI Value
10002	0x0001	1 bit	CH1 DI Value
10003	0x0002	1 bit	CH2 DI Value
10004	0x0003	1 bit	CH3 DI Value
10005	0x0004	1 bit	CH4 DI Value
10006	0x0005	1 bit	CH5 DI Value
10007	0x0006	1 bit	CH6 DI Value
10008	0x0007	1 bit	CH7 DI Value
10009	0x0008	1 bit	CH8 DI Value
10010	0x0009	1 bit	CH9 DI Value
10011	0x000A	1 bit	CH10 DI Value
10012	0x000B	1 bit	CH11 DI Value

3xxxx Read Only Registers (Function 4)

Reference	Address	Data Type	Description
30001	0x0000	word	CH0 DI Count Value Hi-Byte
30002	0x0001	word	CH0 DI Count Value Lo-Byte
30003	0x0002	word	CH1 DI Count Value Hi-Byte
30004	0x0003	word	CH1 DI Count Value Lo-Byte
30005	0x0004	word	CH2 DI Count Value Hi-Byte
30006	0x0005	word	CH2 DI Count Value Lo-Byte
30007	0x0006	word	CH3 DI Count Value Hi-Byte
30008	0x0007	word	CH3 DI Count Value Lo-Byte
30009	0x0008	word	CH4 DI Count Value Hi-Byte
30010	0x0009	word	CH4 DI Count Value Lo-Byte
30011	0x000A	word	CH5 DI Count Value Hi-Byte
30012	0x000B	word	CH5 DI Count Value Lo-Byte
30013	0x000C	word	CH6 DI Count Value Hi-Byte
30014	0x000D	word	CH6 DI Count Value Lo-Byte
30015	0x000E	word	CH7 DI Count Value Hi-Byte
30016	0x000F	word	CH7 DI Count Value Lo-Byte
30017	0x0010	word	CH8 DI Count Value Hi-Byte
30018	0x0011	word	CH8 DI Count Value Lo-Byte
30019	0x0012	word	CH9 DI Count Value Hi-Byte
30020	0x0013	word	CH9 DI Count Value Lo-Byte
30021	0x0014	word	CH10 DI Count Value Hi-Byte
30022	0x0015	word	CH10 DI Count Value Lo-Byte
30023	0x0016	word	CH11 DI Count Value Hi-Byte
30024	0x0017	word	CH11 DI Count Value Lo-Byte

// for Citect SCADA compatibility, I/O data can be WORD accessed as well			
312289	0x3000	word	CH0 DI Value
312290	0x3001	word	CH1 DI Value
312291	0x3002	word	CH2 DI Value
312292	0x3003	word	CH3 DI Value
312293	0x3004	word	CH4 DI Value
312294	0x3005	word	CH5 DI Value
312295	0x3006	word	CH6 DI Value
312296	0x3007	word	CH7 DI Value
312297	0x3008	word	CH8 DI Value
312298	0x3009	word	CH9 DI Value
312299	0x300A	word	CH10 DI Value
312300	0x300B	word	CH11 DI Value

4xxxx Read/Write Registers (Functions 3, 6, 16)

Reference	Address	Data Type	Description
40001	0x0000	word	CH0 DO Pulse Output Count Value Hi-Byte
40002	0x0001	word	CH0 DO Pulse Output Count Value Lo-Byte
40003	0x0002	word	CH1 DO Pulse Output Count Value Hi-Byte
40004	0x0003	word	CH1 DO Pulse Output Count Value Lo-Byte
40005	0x0004	word	CH2 DO Pulse Output Count Value Hi-Byte
40006	0x0005	word	CH2 DO Pulse Output Count Value Lo-Byte
40007	0x0006	word	CH3 DO Pulse Output Count Value Hi-Byte
40008	0x0007	word	CH3 DO Pulse Output Count Value Lo-Byte
40009	0x0008	word	CH4 DO Pulse Output Count Value Hi-Byte
40010	0x0009	word	CH4 DO Pulse Output Count Value Lo-Byte
40011	0x000A	word	CH5 DO Pulse Output Count Value Hi-Byte
40012	0x000B	word	CH5 DO Pulse Output Count Value Lo-Byte
40013	0x000C	word	CH6 DO Pulse Output Count Value Hi-Byte
40014	0x000D	word	CH6 DO Pulse Output Count Value Lo-Byte
40015	0x000E	word	CH7 DO Pulse Output Count Value Hi-Byte
40016	0x000F	word	CH7 DO Pulse Output Count Value Lo-Byte
40017	0x0010	word	CH0 DO Pulse Low Signal Width
40018	0x0011	word	CH1 DO Pulse Low Signal Width
40019	0x0012	word	CH2 DO Pulse Low Signal Width
40020	0x0013	word	CH3 DO Pulse Low Signal Width
40021	0x0014	word	CH4 DO Pulse Low Signal Width
40022	0x0015	word	CH5 DO Pulse Low Signal Width
40023	0x0016	word	CH6 DO Pulse Low Signal Width
40024	0x0017	word	CH7 DO Pulse Low Signal Width
40025	0x0018	word	CH0 DO PulseHigh Signal Width
40026	0x0019	word	CH1 DO PulseHigh Signal Width
40027	0x001A	word	CH2 DO PulseHigh Signal Width
40028	0x001B	word	CH3 DO PulseHigh Signal Width
40029	0x001C	word	CH4 DO PulseHigh Signal Width
40030	0x001D	word	CH5 DO PulseHigh Signal Width
40031	0x001E	word	CH6 DO PulseHigh Signal Width

40032	0x001F	word	CH7 DO PulseHigh Signal Width
40033	0x0020	word	CH0 DO Mode 0: DO 1: Pulse
40034	0x0021	word	CH1 DO Mode 0: DO 1: Pulse
40035	0x0022	word	CH2 DO Mode 0: DO 1: Pulse
40036	0x0023	word	CH3 DO Mode 0: DO 1: Pulse
40037	0x0024	word	CH4 DO Mode 0: DO 1: Pulse
40038	0x0025	word	CH5 DO Mode 0: DO 1: Pulse
40039	0x0026	word	CH6 DO Mode 0: DO 1: Pulse
40040	0x0027	word	CH7 DO Mode 0: DO 1: Pulse
40041	0x0028	word	CH0 DI Count Filter
40042	0x0029	word	CH1 DI Count Filter
40043	0x002A	word	CH2 DI Count Filter
40044	0x002B	word	CH3 DI Count Filter
40045	0x002C	word	CH4 DI Count Filter
40046	0x002D	word	CH5 DI Count Filter
40047	0x002E	word	CH6 DI Count Filter
40048	0x002F	word	CH7 DI Count Filter
40049	0x0030	word	CH8 DI Count Filter
40050	0x0031	word	CH9 DI Count Filter
40051	0x0032	word	CH10 DI Count Filter
40052	0x0033	word	CH11 DI Count Filter
40053	0x0034	word	CH0 DI Mode 0: DI 1: Count Others : return Illegal Data Value
40054	0x0035	word	CH1 DI Mode 0: DI 1: Count Others : return Illegal Data Value
40055	0x0036	word	CH2 DI Mode 0: DI 1: Count Others : return Illegal Data Value
40056	0x0037	word	CH3 DI Mode 0: DI 1: Count Others : return Illegal Data Value
40057	0x0038	word	CH4 DI Mode 0: DI 1: Count Others : return Illegal Data Value
40058	0x0039	word	CH5 DI Mode 0: DI 1: Count Others : return Illegal Data Value
40059	0x003A	word	CH6 DI Mode 0: DI 1: Count Others : return Illegal Data Value

40060	0x003B	word	CH7 DI Mode 0: DI 1: Count Others : return Illegal Data Value
40061	0x003C	word	CH8 DI Mode 0: DI 1: Count Others : return Illegal Data Value
40062	0x003D	word	CH9 DI Mode 0: DI 1: Count Others : return Illegal Data Value
40063	0x003E	word	CH10 DI Mode 0: DI 1: Count Others : return Illegal Data Value
40064	0x003F	word	CH11 DI Mode 0: DI 1: Count Others : return Illegal Data Value
// for Citect SCADA compatibility, I/O data can be WORD accessed as well			
40257	0x0100	1 word	CH0 DO Value 0: Off 1: On
40258	0x0101	1 word	CH1 DO Value 0: Off 1: On
40259	0x0102	1 word	CH2 DO Value 0: Off 1: On
40260	0x0103	1 word	CH3 DO Value 0: Off 1: On
40261	0x0104	1 word	CH4 DO Value 0: Off 1: On
40262	0x0105	1 word	CH5 DO Value 0: Off 1: On
40263	0x0106	1 word	CH6 DO Value 0: Off 1: On
40264	0x0107	1 word	CH7 DO Value 0: Off 1: On
40265	0x0108	1 word	CH0 DO Power On Value 0: Off 1: On
40266	0x0109	1 word	CH1 DO Power On Value 0: Off 1: On
40267	0x010A	1 word	CH2 DO Power On Value 0: Off 1: On
40268	0x010B	1 word	CH3 DO Power On Value 0: Off 1: On
40269	0x010C	1 word	CH4 DO Power On Value 0: Off 1: On
40270	0x010D	1 word	CH5 DO Power On Value 0: Off 1: On
40271	0x010E	1 word	CH6 DO Power On Value 0: Off 1: On
40272	0x010F	1 word	CH7 DO Power On Value 0: Off 1: On
40273	0x0110	1 word	CH0 DO Safe Mode Value 0: Off 1: On
40274	0x0111	1 word	CH1 DO Safe Mode Value 0: Off 1: On
40275	0x0112	1 word	CH2 DO Safe Mode Value 0: Off 1: On
40276	0x0113	1 word	CH3 DO Safe Mode Value 0: Off 1: On
40277	0x0114	1 word	CH4 DO Safe Mode Value 0: Off 1: On
40278	0x0115	1 word	CH5 DO Safe Mode Value 0: Off 1: On
40279	0x0116	1 word	CH6 DO Safe Mode Value 0: Off 1: On
40280	0x0117	1 word	CH7 DO Safe Mode Value 0: Off 1: On
40281	0x0118	1 word	CH0 DO Pulse Operate Status 0: Stop 1: Start
40282	0x0119	1 word	CH1 DO Pulse Operate Status 0: Stop 1: Start
40283	0x011A	1 word	CH2 DO Pulse Operate Status 0: Stop 1: Start
40284	0x011B	1 word	CH3 DO Pulse Operate Status 0: Stop 1: Start
40285	0x011C	1 word	CH4 DO Pulse Operate Status 0: Stop 1: Start
40286	0x011D	1 word	CH5 DO Pulse Operate Status 0: Stop 1: Start
40287	0x011E	1 word	CH6 DO Pulse Operate Status 0: Stop 1: Start
40288	0x011F	1 word	CH7 DO Pulse Operate Status 0: Stop 1: Start
40289	0x0120	1 word	CH0 DO PowerOn Pulse Operate Status 0: Stop 1: Start

40290	0x0121	1 word	CH1 DO PowerOn Pulse Operate Status 0: Stop 1: Start
40291	0x0122	1 word	CH2 DO PowerOn Pulse Operate Status 0: Stop 1: Start
40292	0x0123	1 word	CH3 DO PowerOn Pulse Operate Status 0: Stop 1: Start
40293	0x0124	1 word	CH4 DO PowerOn Pulse Operate Status 0: Stop 1: Start
40294	0x0125	1 word	CH5 DO PowerOn Pulse Operate Status 0: Stop 1: Start
40295	0x0126	1 word	CH6 DO PowerOn Pulse Operate Status 0: Stop 1: Start
40296	0x0127	1 word	CH7 DO PowerOn Pulse Operate Status 0: Stop 1: Start
40297	0x0128	1 word	CH0 DO Safe Mode Pulse Operate Status 0: Stop 1: Start
40298	0x0129	1 word	CH1 DO Safe Mode Pulse Operate Status 0: Stop 1: Start
40299	0x012A	1 word	CH2 DO Safe Mode Pulse Operate Status 0: Stop 1: Start
40300	0x012B	1 word	CH3 DO Safe Mode Pulse Operate Status 0: Stop 1: Start
40301	0x012C	1 word	CH4 DO Safe Mode Pulse Operate Status 0: Stop 1: Start
40302	0x012D	1 word	CH5 DO Safe Mode Pulse Operate Status 0: Stop 1: Start
40303	0x012E	1 word	CH6 DO Safe Mode Pulse Operate Status 0: Stop 1: Start
40304	0x012F	1 word	CH7 DO Safe Mode Pulse Operate Status 0: Stop 1: Start
40305	0x0130	1 word	CH0 DI Counter Operate Status 0: Stop 1: Start
40306	0x0131	1 word	CH1 DI Counter Operate Status 0: Stop 1: Start
40307	0x0132	1 word	CH2 DI Counter Operate Status 0: Stop 1: Start
40308	0x0133	1 word	CH3 DI Counter Operate Status 0: Stop 1: Start
40309	0x0134	1 word	CH4 DI Counter Operate Status 0: Stop 1: Start
40310	0x0135	1 word	CH5 DI Counter Operate Status 0: Stop 1: Start
40311	0x0136	1 word	CH6 DI Counter Operate Status 0: Stop 1: Start
40312	0x0137	1 word	CH7 DI Counter Operate Status 0: Stop 1: Start
40313	0x0138	1 word	CH8 DI Counter Operate Status 0: Stop 1: Start
40314	0x0139	1 word	CH9 DI Counter Operate Status 0: Stop 1: Start
40315	0x013A	1 word	CH10 DI Counter Operate Status 0: Stop 1: Start
40316	0x013B	1 word	CH11 DI Counter Operate Status 0: Stop 1: Start
40317	0x013C	1 word	CH0 DI Clear Count Value Read: always return: 0 Write: 1 : Clear counter value0 : Return illegal data value(0x03)
40318	0x013D	1 word	CH1 DI Clear Count Value Read: always return: 0 Write: 1 : Clear counter value 0 : Return illegal data value(0x03)
40319	0x013E	1 word	CH2 DI Clear Count Value Read: always return: 0 Write: 1 : Clear counter value 0 : Return illegal

			data value(0x03)
40320	0x013F	1 word	CH3 DI Clear Count Value Read: always return: 0 Write: 1 : Clear counter value 0 : Return illegal data value(0x03)
40321	0x0140	1 word	CH4 DI Clear Count Value Read: always return: 0 Write: 1 : Clear counter value 0 : Return illegal data value(0x03)
40322	0x0141	1 word	CH5 DI Clear Count Value Read: always return: 0 Write: 1 : Clear counter value 0 : Return illegal data value(0x03)
40323	0x0142	1 word	CH6 DI Clear Count Value Read: always return: 0 Write: 1 : Clear counter value 0 : Return illegal data value(0x03)
40324	0x0143	1 word	CH7 DI Clear Count Value Read: always return: 0 Write: 1 : Clear counter value 0 : Return illegal data value(0x03)
40325	0x0144	1 word	CH8 DI Clear Count Value Read: always return: 0 Write: 1 : Clear counter value 0 : Return illegal data value(0x03)
40326	0x0145	1 word	CH9 DI Clear Count Value Read: always return: 0 Write: 1 : Clear counter value 0 : Return illegal data value(0x03)
40327	0x0146	1 word	CH10 DI Clear Count Value Read: always return: 0 Write: 1 : Clear counter value 0 : Return illegal data value(0x03)
40328	0x0147	1 word	CH11 DI Clear Count Value Read: always return: 0 Write: 1 : Clear counter value 0 : Return illegal data value(0x03)
40329	0x0148	1 word	CH0 DI OverFlow Status Read: 0 : Normal 1 : Overflow Write : 0 : Clear overflow status 1 : Return illegal data value (0x03)
40330	0x0149	1 word	CH1 DI OverFlow Status Read: 0 : Normal 1 : Overflow Write : 0 : Clear overflow status 1 : Return illegal data value (0x03)
40331	0x014A	1 word	CH2 DI OverFlow Status Read: 0 : Normal 1 : Overflow Write : 0 : Clear overflow status 1 : Return illegal data value (0x03)
40332	0x014B	1 word	CH3 DI OverFlow Status Read: 0 : Normal 1 : Overflow Write : 0 : Clear overflow status 1 : Return illegal data value (0x03)
40333	0x014C	1 word	CH4 DI OverFlow Status Read: 0 : Normal 1 : Overflow Write : 0 : Clear overflow status 1 : Return illegal data value (0x03)
40334	0x014D	1 word	CH5 DI OverFlow Status Read: 0 : Normal 1 : Overflow Write : 0 : Clear overflow status

			1 : Return illegal data value (0x03)
40335	0x014E	1 word	CH6 DI OverFlow Status Read: 0 : Normal 1 : Overflow Write : 0 : Clear overflow status 1 : Return illegal data value (0x03)
40336	0x014F	1 word	CH7 DI OverFlow Status Read: 0 : Normal 1 : Overflow Write : 0 : Clear overflow status 1 : Return illegal data value (0x03)
40337	0x0150	1 word	CH8 DI OverFlow Status Read: 0 : Normal 1 : Overflow Write : 0 : Clear overflow status 1 : Return illegal data value (0x03)
40338	0x0151	1 word	CH9 DI OverFlow Status Read: 0 : Normal 1 : Overflow Write : 0 : Clear overflow status 1 : Return illegal data value (0x03)
40339	0x0152	1 word	CH10 DI OverFlow Status Read: 0 : Normal 1 : Overflow Write : 0 : Clear overflow status 1 : Return illegal data value (0x03)
40340	0x0153	1 word	CH11 DI OverFlow Status Read: 0 : Normal 1 : Overflow Write : 0 : Clear overflow stat 1 : Return illegal data value (0x03)
40341	0x0154	1 word	CH0 DI Counter Trigger , 0=Low to High, 1=High to Low
40342	0x0155	1 word	CH1 DI Counter Trigger , 0=Low to High, 1=High to Low
40343	0x0156	1 word	CH2 DI Counter Trigger , 0=Low to High, 1=High to Low
40344	0x0157	1 word	CH3 DI Counter Trigger , 0=Low to High, 1=High to Low
40345	0x0158	1 word	CH4 DI Counter Trigger , 0=Low to High, 1=High to Low
40346	0x0159	1 word	CH5 DI Counter Trigger , 0=Low to High, 1=High to Low
40347	0x015A	1 word	CH6 DI Counter Trigger , 0=Low to High, 1=High to Low
40348	0x015B	1 word	CH7 DI Counter Trigger , 0=Low to High, 1=High to Low
40349	0x015C	1 word	CH8 DI Counter Trigger , 0=Low to High, 1=High to Low
40350	0x015D	1 word	CH9 DI Counter Trigger , 0=Low to High, 1=High to Low
40351	0x015E	1 word	CH10 DI Counter Trigger , 0=Low to High, 1=High to Low
40352	0x015F	1 word	CH11 DI Counter Trigger , 0=Low to High, 1=High to Low

			to Low
40353	0x0160	1 word	CH0 DI PowerOn Counter Operate Status 0: Stop 1: Start
40354	0x0161	1 word	CH1 DI PowerOn Counter Operate Status 0: Stop 1: Start
40355	0x0162	1 word	CH2 DI PowerOn Counter Operate Status 0: Stop 1: Start
40356	0x0163	1 word	CH3 DI PowerOn Counter Operate Status 0: Stop 1: Start
40357	0x0164	1 word	CH4 DI PowerOn Counter Operate Status 0: Stop 1: Start
40358	0x0165	1 word	CH5 DI PowerOn Counter Operate Status 0: Stop 1: Start
40359	0x0166	1 word	CH6 DI PowerOn Counter Operate Status 0: Stop 1: Start
40360	0x0167	1 word	CH7 DI PowerOn Counter Operate Status 0: Stop 1: Start
40361	0x0168	1 word	CH8 DI PowerOn Counter Operate Status 0: Stop 1: Start
40362	0x0169	1 word	CH9 DI PowerOn Counter Operate Status 0: Stop 1: Start
40363	0x016A	1 word	CH10 DI PowerOn Counter Operate Status 0: Stop 1: Start
40364	0x016B	1 word	CH11 DI PowerOn Counter Operate Status 0: Stop 1: Start
40365	0x016C	1 word	CH0 DI Safe Mode Counter Operate Status 0: Stop 1: Start
40366	0x016D	1 word	CH1 DI Safe Mode Counter Operate Status 0: Stop 1: Start
40367	0x016E	1 word	CH2 DI Safe Mode Counter Operate Status 0: Stop 1: Start
40368	0x016F	1 word	CH3 DI Safe Mode Counter Operate Status 0: Stop 1: Start
40369	0x0170	1 word	CH4 DI Safe Mode Counter Operate Status 0: Stop 1: Start
40370	0x0171	1 word	CH5 DI Safe Mode Counter Operate Status 0: Stop 1: Start
40371	0x0172	1 word	CH6 DI Safe Mode Counter Operate Status 0: Stop 1: Start
40372	0x0173	1 word	CH7 DI Safe Mode Counter Operate Status 0: Stop 1: Start
40373	0x0174	1 word	CH8 DI Safe Mode Counter Operate Status 0: Stop 1: Start
40374	0x0175	1 word	CH9 DI Safe Mode Counter Operate Status 0: Stop 1: Start
40375	0x0176	1 word	CH10 DI Safe Mode Counter Operate Status 0: Stop 1: Start
40376	0x0177	1 word	CH11 DI Safe Mode Counter Operate Status 0: Stop 1: Start

Function 8

Sub-function	Data Field (Request)	Data Field (Response)	Description
0x0001	0x0000	Echo Request Data	Reboot
0x0001	0xFF00	Echo Request Data	Reset to Factory defaults

Used Network Port Numbers

E2210 Network Port Usage

Port	Type	Usage
80	TCP	Web server
502	TCP	Modbus communication
161	TCP	SNMP
68	UDP	BOOTPC
68	UDP	DHCP
4800	UDP	Auto search
9020	TCP	Peer-to-Peer function
69	UDP	Export/import file
9000	TCP	Active Message (default)
9000	UDP	Active Message (default)
4040	TCP	ioEventLog

D

SNMP MIB II

RFC1213 MIB II Supported SNMP Variables

The following SNMP variables are built into the ioLogik firmware and are compliant with RFC1213 MIB II.

System MIB			
SysDescr	SysObjectID	SysUpTime	SysContact
SysName	SysLocation		

Interfaces MIB			
ifAdminStatus	ifInOctets	ifOperStatus	ifOutUcastPkts
ifDescr	ifInUcastPkts	ifOutDiscards	ifPhysAddress
ifIndex	ifInUnknownProtos	ifOutErrors	ifSpecific
ifInDiscards	ifLastChange	ifOutNUcastPkts	ifSpeed
ifInErrors	ifMtu	ifOutOctets	ifType
ifInNUcastPkts	ifNumber	ifOutQLen	

IP MIB			
ipAdEntAddr	ipFragOKs	IpNetToMediaType	ipRouteIfIndex
ipAdEntBcastAddr	ipInAddrErrors	ipOutDiscards	ipRouteInfo
ipAdEntIfIndex	ipInDelivers	ipOutNoRoutes	ipRouteMask
ipAdEntNetMask	ipInDiscards	ipOutRequests	ipRouteMetric1
ipAdEntReasmMaxSiz	ipInHdrErrors	ipReasmFails	ipRouteMetric2
ipDefaultTTL	ipInreceives	ipReasmOKs	ipRouteMetric3
ipForwarding	ipInUnknownProtos	ipReasmReqds	ipRouteMetric4
ipForwDatagrams	IpNetToMediaIfIndex	ipReasmTimeout	ipRouteMetric5
ipFragCreates	IpNetToMediaNetAddr	ipRouteAge	ipRouteNextHop
ipFragFails	IpNetToMediaPhysAdd	ipRouteDest	ipRouteProto
ipRouteType			
IpRoutingDiscards			

IP MIB			
ICMP MIB			
IcmpInAddrMasks	IcmpInRedirects	IcmpOutEchoReps	IcmpOutTimeExcds
IcmpInDestUnreachs	IcmpInSrcQuenchs	IcmpOutEchos	IcmpOutTimestampRep
IcmpInEchoReps	IcmpInTimeExcds	IcmpOutErrors	IcmpOutTimestamps
IcmpInEchos	IcmpInTimestamps	IcmpOutMsgs	IcmpTimestampReps
IcmpInErrors	IcmpOutAddrMaskReps	IcmpOutParmProbs	
IcmpInMsgs	IcmpOutAddrMasks	IcmpOutRedirects	
IcmpInParmProbs	IcmpOutDestUnreachs	IcmpOutSrcQuenchs	

UDP MIB			
UdpInDatagrams	UdpLocalAddress	UdpNoPorts	
UdpInErrors	UdpLocalPort	UdpOutDatagrams	

Address Translation MIB			
AtIfIndex	AtPhysAddress	AtNetAddress	

TCP MIB			
tcpActiveOpens	tcpConnRemPort	tcpInSegs	tcpRetransSegs
tcpAttemptFails	tcpConnState	tcpMaxConn	tcpRtoAlgorithm
tcpConnLocalAddress	tcpCurrEstab	tcpOutRsts	tcpRtoMax
tcpConnLocalPort	tcpEstabResets	tcpOutSegs	tcpRtoMin
tcpConnRemAddress	tcpInErrs	tcpPassiveOpens	

SNMP MIB		
snmpEnableAuthenTraps	snmpInGetRequests	snmpInTotalSetVars
snmpInASNParseErrs	snmpInGetResponses	snmpInTraps
snmpInBadCommunityNames	snmpInNoSuchNames	snmpOutBadValues
snmpInBadCommunityUses	snmpInPkts	snmpOutGenErrs
snmpInBadValues	snmpInReadOnlys	snmpOutGetNexts
snmpInBadVersions	snmpInSetRequests	snmpOutGetRequests
snmpInGenErrs	snmpInTooBigs	snmpOutGetResponses
snmpInGetNexts	snmpInTotalReqVars	snmpOutNoSuchNames
snmpOutPkts	snmpOutTooBigs	
snmpOutSetRequests	snmpOutTraps	

Private MIB File and SNMP Variables

Moxa also provides an SNMP to I/O MIB file that can help you monitor I/O status with SNMP software. You can find the MIB file on the Document and Software CD.

Moxa IO MIB			
DI00-Filter	DI07-Filter	DO01-Type	DO06-Type
DI00-Index	DI07-Index	DO01-Low Width	DO06-Low Width
DI00-Mode	DI07-Mode	DO01-High Width	DO06-High Width
DI00-Status	DI07-Status	DO01-PulseStart	DO06-PulseStart
DI00-Type	DI07-Type	DO02-Index	DO07-Index
DI01-Filter	DI08-Filter	DO02-Mode	DO07-Mode
DI01-Index	DI08-Index	DO02-Status	DO07-Status
DI01-Mode	DI08-Mode	DO02-Type	DO07-Type
DI01-Status	DI08-Status	DO02-Low Width	DO07-Low Width
DI01-Type	DI08-Type	DO02-High Width	DO07-High Width
DI02-Filter	DI09-Filter	DO02-PulseStart	DO07-PulseStart
DI02-Index	DI09-Index	DO03-Index	firmwareVersion
DI02-Mode	DI09-Mode	DO03-Mode	serverModel
DI02-Status	DI09-Status	DO03-Status	systemTime
DI02-Type	DI09-Type	DO03-Type	totalChannelNumber
DI03-Filter	DI10-Filter	DO03-Low Width	
DI03-Index	DI10-Index	DO03-High Width	
DI03-Mode	DI10-Mode	DO03-PulseStart	
DI03-Status	DI10-Status	DO04-Index	
DI03-Type	DI10-Type	DO04-Mode	
DI04-Filter	DI11-Filter	DO04-Status	
DI04-Index	DI11-Index	DO04-Type	
DI04-Mode	DI11-Mode	DO04-Low Width	
DI04-Status	DI11-Status	DO04-High Width	
DI04-Type	DI11-Type	DO04-PulseStart	
DI05-Filter	DO00-Index	DO05-Index	
DI05-Index	DO00-Mode	DO05-Mode	
DI05-Mode	DO00-Status	DO05-Status	
DI05-Status	DO00-Type	DO05-Type	
DI05-Type	DO00-Low Width	DO05-Low Width	
DI06-Filter	DO00-High Width	DO05-High Width	
DI06-Index	DO00-PulseStart	DO05-PulseStart	

Moxa IO MIB			
DI06-Mode	DO01-Index	DO06-Index	
DI06-Status	DO01-Mode	DO06-Mode	
DI06-Type	DO01-Status	DO06-Status	

E

Factory Default Settings

The ioLogik E2210 is configured with the following factory defaults:

Default IP address:	192.168.127.254
Default Netmask:	255.255.255.0
Default Gateway:	0.0.0.0
Communication watchdog:	Disable
Modbus/TCP Alive Check:	On
Modbus/TCP Timeout Interval:	60 sec
DI Mode:	DI
Filter time:	100 × 0.5 ms
Trigger for counter:	Lo to Hi
Counter status:	Stop
DO Mode:	DO
DO Safe Status:	Off
Power on status:	Off
Low width for pulse:	1 × 0.5 ms
Hi width for pulse:	1 × 0.5 ms
Output pulses:	0 (continuous)
Password:	NONE
Module Name:	NONE
Module Location:	NONE
SNMP:	Enable
Community:	Public
Contact:	NONE
Location:	NONE
Click&Go	NONE

F

Pinouts and Cable Wiring

Ethernet Port Pinouts

Pin	Signal
1	Tx+
2	Tx-
3	Rx+
6	Rx-

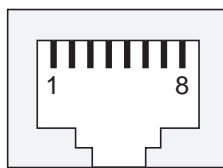

Serial Port Pinouts

E2210 RS-485 Network Adapter Pin Assignment

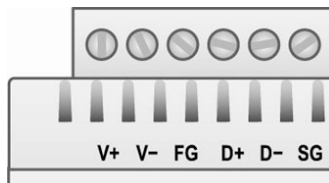

Digital Input Wiring

Structure

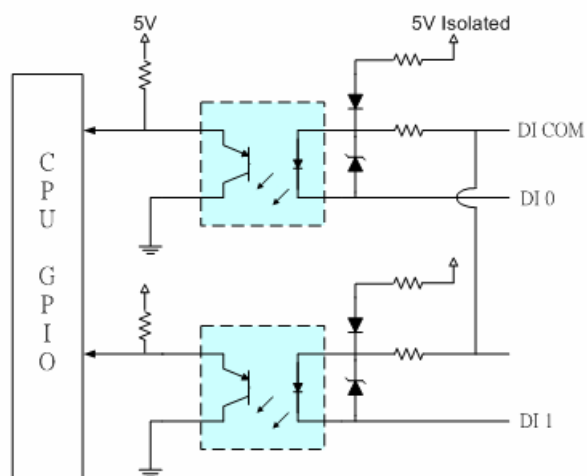

Dry Contact

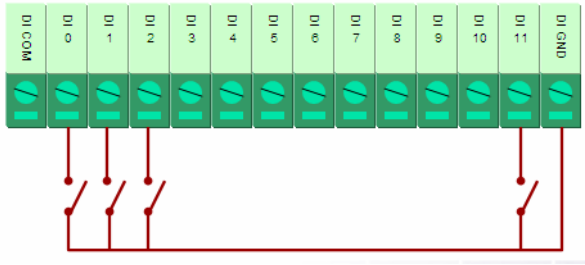

Wet Contact



Note: If you are using wet contacts, you must connect “DI COM” to power. For testing purposes, you may connect “DI COM” to the V+ terminal of a power supply.

Example

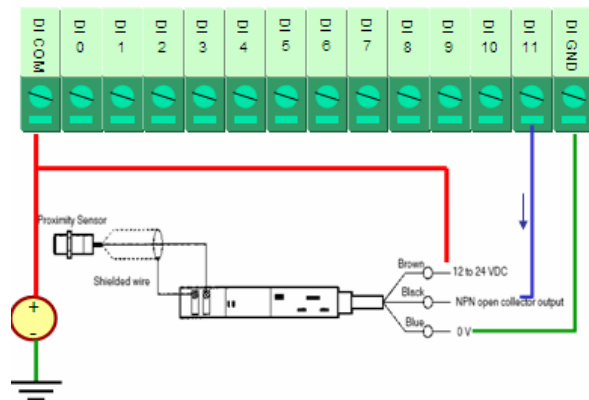

Digital Output

Structure

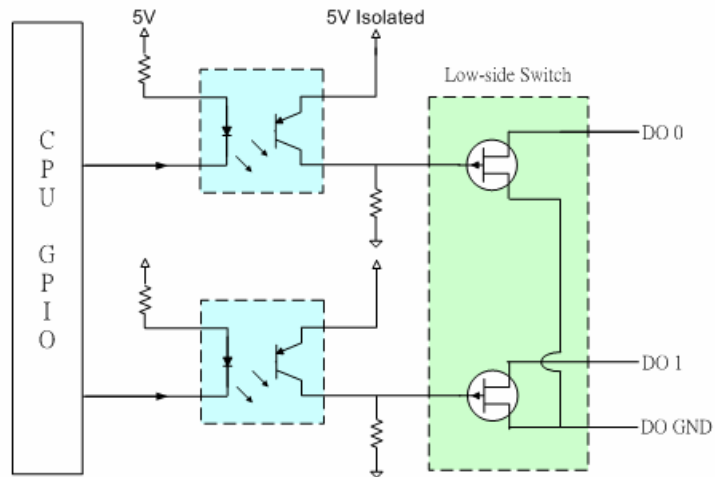

Output Channel

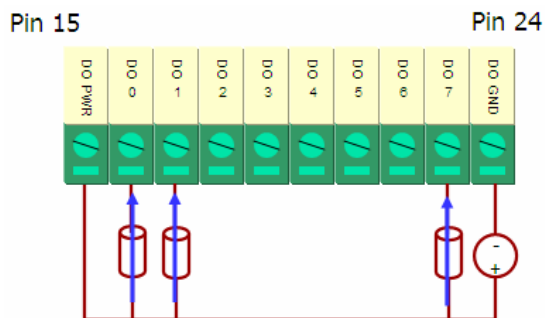

* DO PWR is for powering up the *field Power* LED.

Pin Assignment of Terminal Blocks

Ethernet

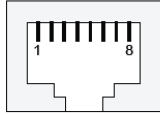

PIN	Signals
1	Tx+
2	Tx-
3	Rx+
6	Rx-

Power / RS-485

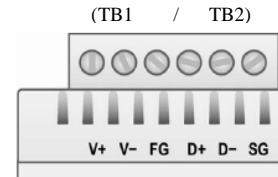

I/O (left to right)

(TB3)

Pin	1	2	3	4	5	6	7	8	9	10	11	12
Signal	DI.COM	DI0	DI1	DI2	DI3	DI4	DI5	DI6	DI7	DI8	DI9	DI10
Pin	13	14	15	16	17	18	19	20	21	22	23	24
Signal	DI11	DI.GND	DO.PWR	DO0	DO1	DO2	DO3	DO4	DO5	DO6	DO7	DO.GND

