

LAMP®

MonoFlat FAD® FAD-44、FAD-44L

Wooden Frame Type Instruction Manual

Thank you for selecting our product. Before starting installation, please read this manual thoroughly to ensure correct installation. Please keep this manual at hand for future reference.

■ About this product.

Lateral swing mechanism hardware that can be installed in narrow spaces where a normally hinged door may not fit.
Ideal for tight front space applications

- When placing cabinets next to each other the front will be completely flat when the door is closed.
- There is no need of embedding a rail on the floor.
- It is possible to adjust the door vertically (-3 to +7 mm), horizontally (± 7 mm), as well as in depth and parallel.
*In order to make it possible to adjust, make sure that the shelf board can be detached for access.

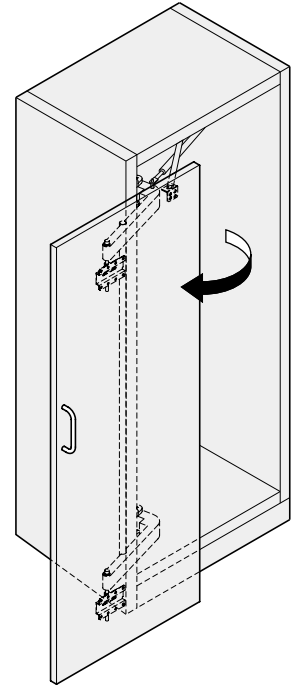

■ For your safety work and operation.

	This symbol denotes prohibited actions.
	This symbol denotes what must be done.



WARNING: If these warnings are not followed, it may result in death or serious injury.

- ❗ This (sliding door system) should be installed by an experienced person who has correct knowledge. If the system is not installed correctly, the door will not operate smoothly, and or may cause injury.
- ❗ It is necessary to manufacture the frame with sufficient strength so it endures the weight of the door and impact shocks upon opening/closing the door. Also make sure to only use the designated screws and to fasten them firmly. A frame with poor strength or loose screws might result in improper and slower movement of the door. In the worst case, the door might drop down and cause injury.
- ⊘ Do not try to use this product for any other purposes than originally intended for. Do not use the parts for applications that are out of specification.
- ⊘ Do not disassemble nor modify any parts other than those described in this document.



Caution If these cautions are not followed, it may result in injury or damage.

- ❗ This product is a part for cabinets. After installation, make sure to test the finished product thoroughly to ensure that it is well-functioning and safe.
- ❗ Make sure to follow the designated measurements and specifications as well as horizontal and verticals angles. Make sure that frame and door are not warped nor bent, since it may affect the movement of the door.
- ❗ If cutting any parts, make sure to remove any burr before installation.
- ❗ Make sure to test the screws for slack at regular intervals (one month from first usage, half year and then one time every year is recommended).

■ Notes on works

Handling of product

- The door is not supplied.
- After unpacking the product, check for damages on the parts.

Specifications

Cabinet inside measurement	From 750 mm to 800 mm*	Door thickness	From 24 to 38 mm
	* If the overlay distance on both sides of side plate is 25 mm, the door width should be 800 to 850 mm.	Door weight	Max. 35 kg
Door height	Max. 2380 mm [2980 mm]	Side plate thickness	Min. 25 mm

Note: Check that the cabinet side plate is constructed and assembled in the vertical direction. The size in [] applies to the FAD-44L.

Description of parts

1

Hinge base x 2 Support arm nut x 1 Gas spring nut x 1 Channel rail x 1

Supplied Screw		Q'ty
Countersunk self-tapping screw 4x20		5
Countersunk self-tapping screw 4.5x30		12

2

Support arm x 1 Crank bracket

Upper arm (w/ stopper) x 1

Lower arm x 1 Clear cushion rubber x1 + 1 (spare)

Supplied (for assembling arm) Screw		Q'ty
Hexagon socket head cap screw M6x12		2
Spring washer		2
Cross-recessed blind self-tapping screw 4.5 x 20		4
Square nut M6(No need for this application)		2

3

Pipe length=1990 [2600]

Arm connecting pipe x 1 Pipe clamp x 1

Supplied Screw		Q'ty
Hexagon socket head cap screw M6x35		4
Flat washer		4

4

Gas spring holder x 1 Screw pin x 1

Conical springwasher x 1

Supplied Screw		Q'ty
Hexagon socket head cap screw M6x12		2
Spring washer		2
Flat washer		2
E-ring		2
Square nut M6(No need for this application)		2

5

Bearing housing x 4

Supplied Screw		Q'ty
Hexagon socket head cap screw M6x12		8
Spring washer		8
Square nut M6(No need for this application)		8

6

Positioning unit x 2

Supplied Screw		Q'ty
Cross-recessed blind self-tapping screw 4.5 x 20		16

7

Parts to assemble support arm **2** and positioning unit **6**.

Supplied Screw		Q'ty
Hexagon head bolt M10x150		2
Hexagon nut M10		2
Flat washer 10		2

Gas spring x 1

Brush seal x 1
FAD-44: (5000)x1
FAD-44L: (6000)x1

■ Tools used

- Phillips screwdriver No. 2 - Hexagonal wrench key 5
- Wrench 10, 16 - E-type retaining ring mounter

1

Working in Door and Cabinet

Have a fixing screw pilot hole drilled in the cabinet or have that position marked precisely beforehand. Set core material of which strength is enough for secure fixing to this part.

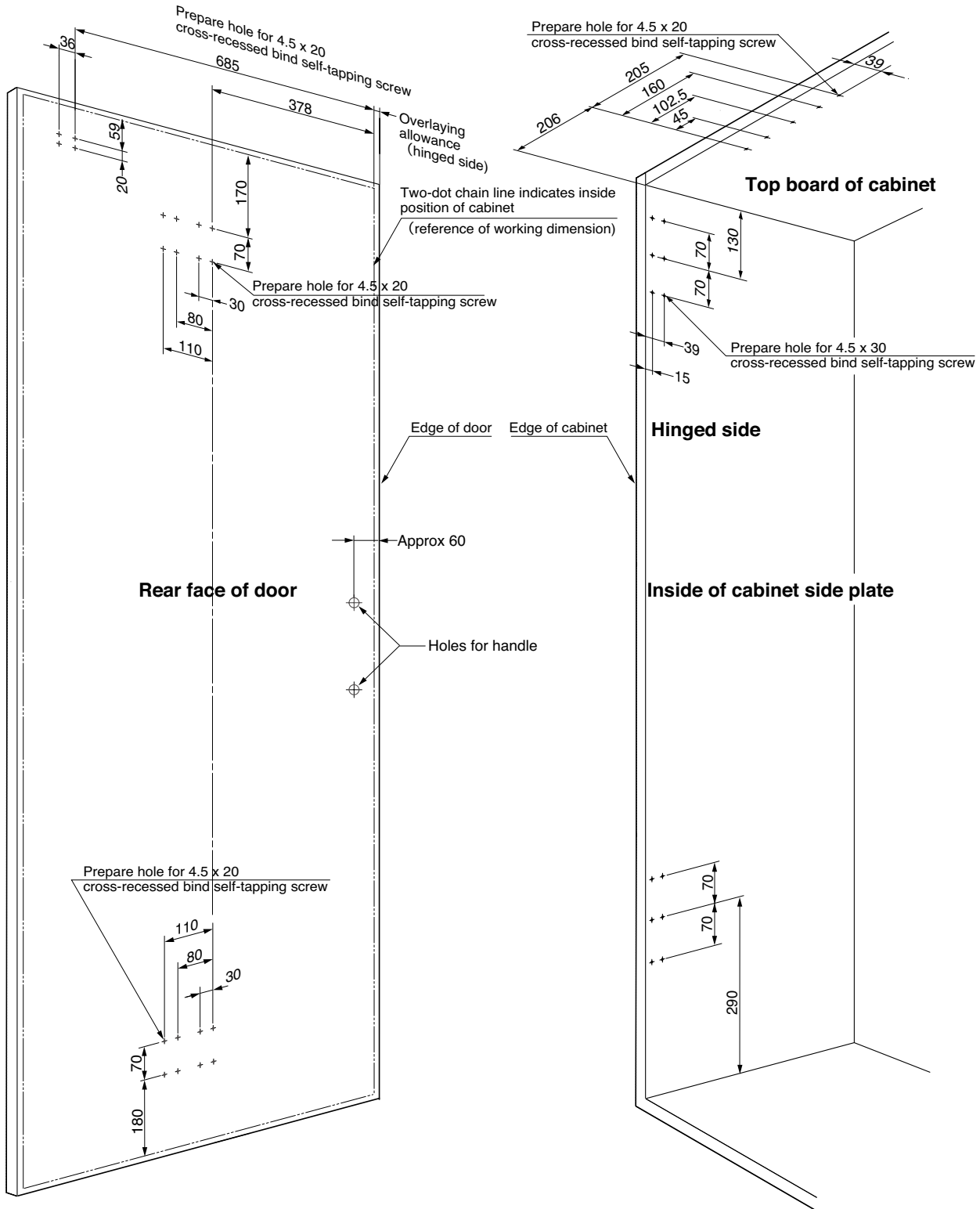

Left side hinged plan

Right side hinged plan can be symmetrical.

2 Installing Parts to Cabinet

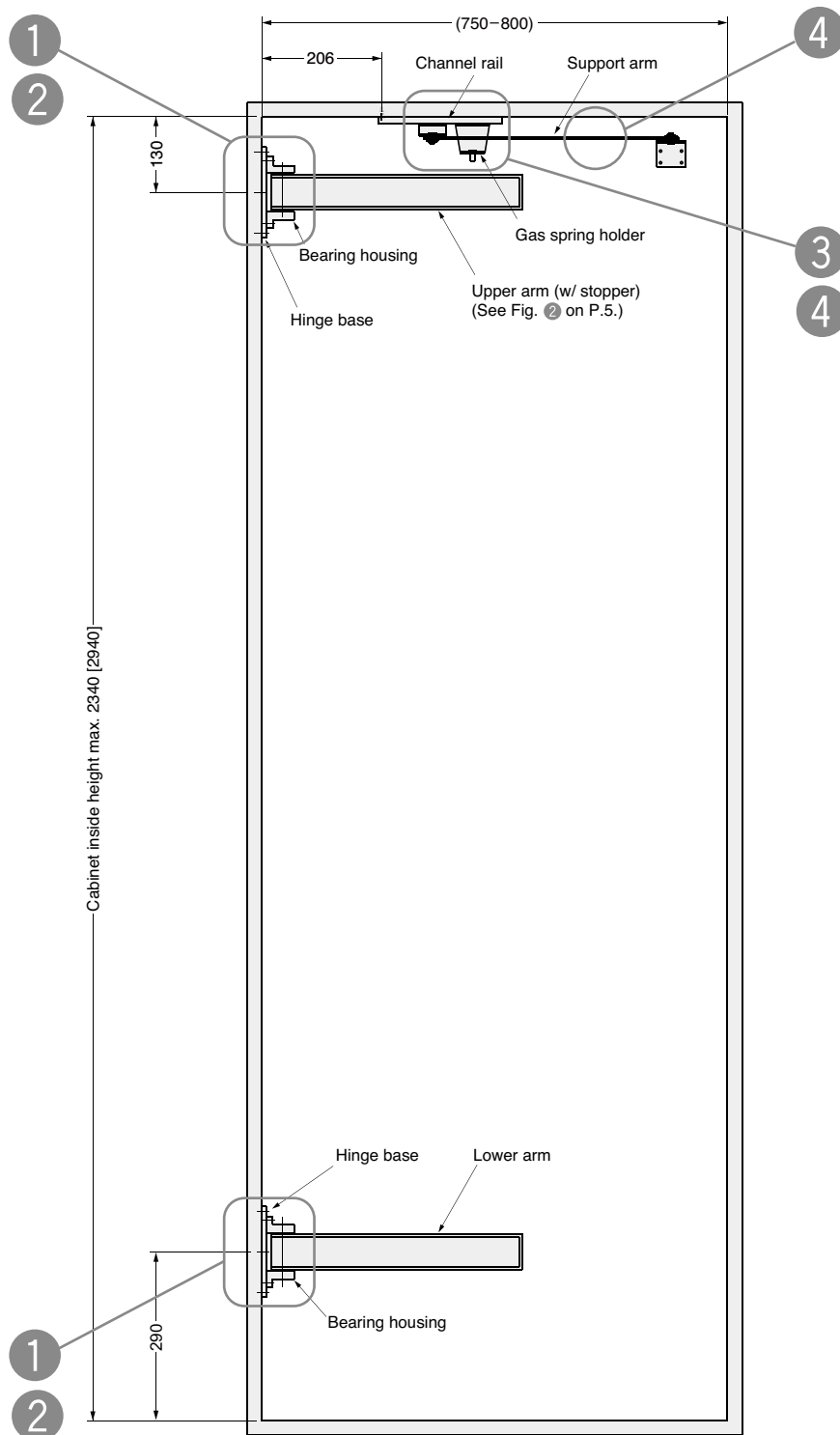

Symbols from ① to ④ shown in the figure indicate the locations described below.

1 Installing hinge base

Use the provided screws to fix each hinge base temporarily to six drilled holes on the cabinet.

Torque the screws in a criss-cross pattern to prevent the hinge base to be warped.

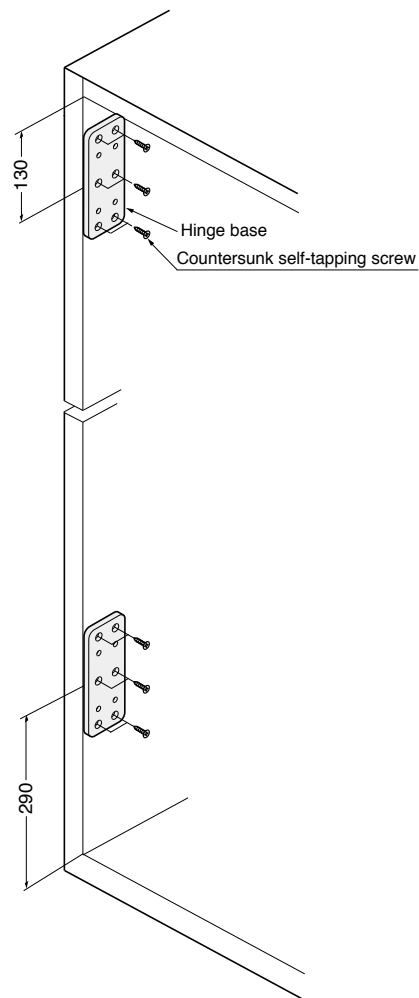

2 Installing upper and lower arms

(1) Fix the lower bearing housing to each hinge base by using the provided screws and spring washers.

Tool: hex key (width across flats 5)

(2) Insert the shaft of the upper arm to the bearing housing, which is identified by the installed stopper.

Assemble the lower arm in the same way.

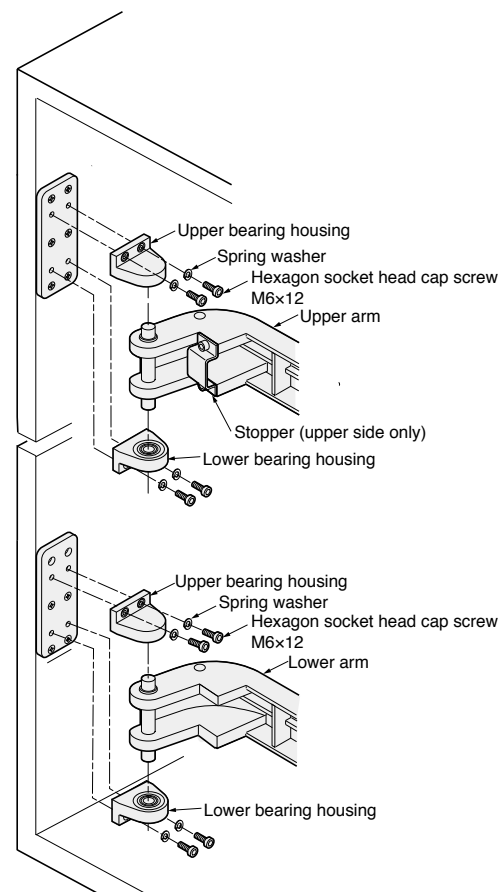

3 Installing channel rail

- (1) Fix the channel rail to the top board with the provided screws.
- (2) When screwing, tighten in order of ① to ⑤ as shown in the right figure.

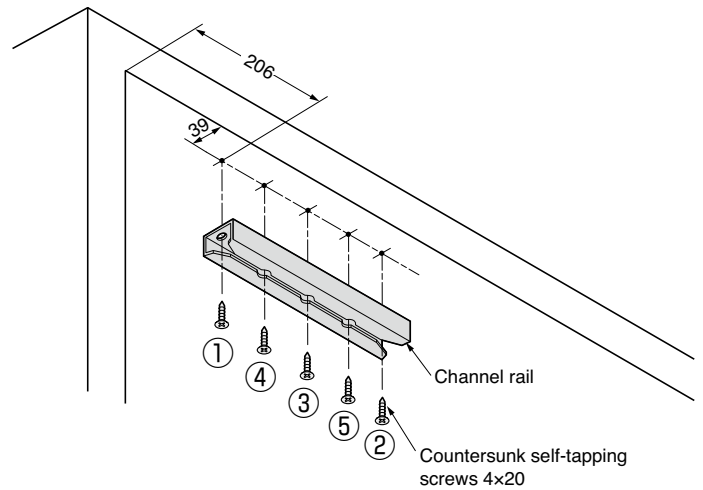

4 Installing Support arm and Gas spring holder

- (1) Assemble the Support arm nut to the Support arm crank bracket with the provided screws. Leave around 5 mm of distance between the nut and the bracket.

Insert the Support arm nut to the channel rail and fix it at the circle-marked position in the right figure.

⚠ Caution

- Be sure to fix the Support arm crank bracket to the direction in the right figure.

- (2) Assemble the Gas spring holder nut to the Gas spring holder with the provided screws.

Leave around 5 mm of distance between the nut and the holder.

Insert the Gas spring holder nut to the channel rail and fix it at the circle-marked position in the right figure. (See ②.) Position the Support arm in front of Gas spring holder as shown in the right figure.

- (3) Tape the Support arm temporarily so that it would not interfere with the installation of the other parts.

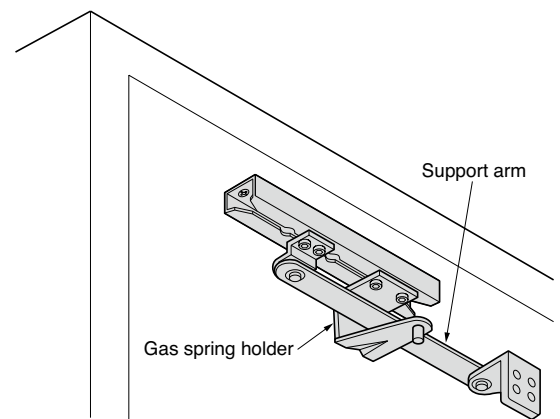
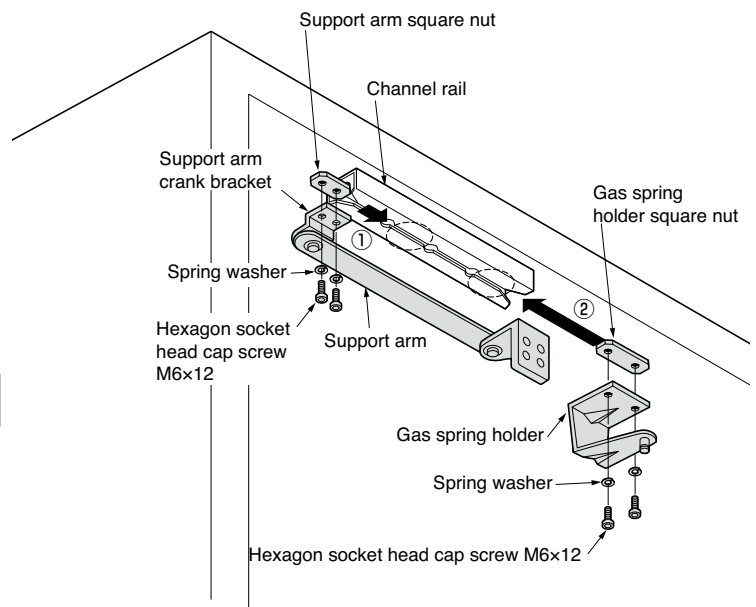

3 Installing Arm Connecting Pipe

1 Cutting Arm connecting pipe

- (1) Pipe length = Cabinet inside height - 350
(This does not include the caps on both ends.)
- (2) Cut the pipe end without the clamp.
- (3) Remove burrs around the cutting edge to prevent injury and enable smooth insertion of the cap.
- (4) Replace the cap on the cut end.

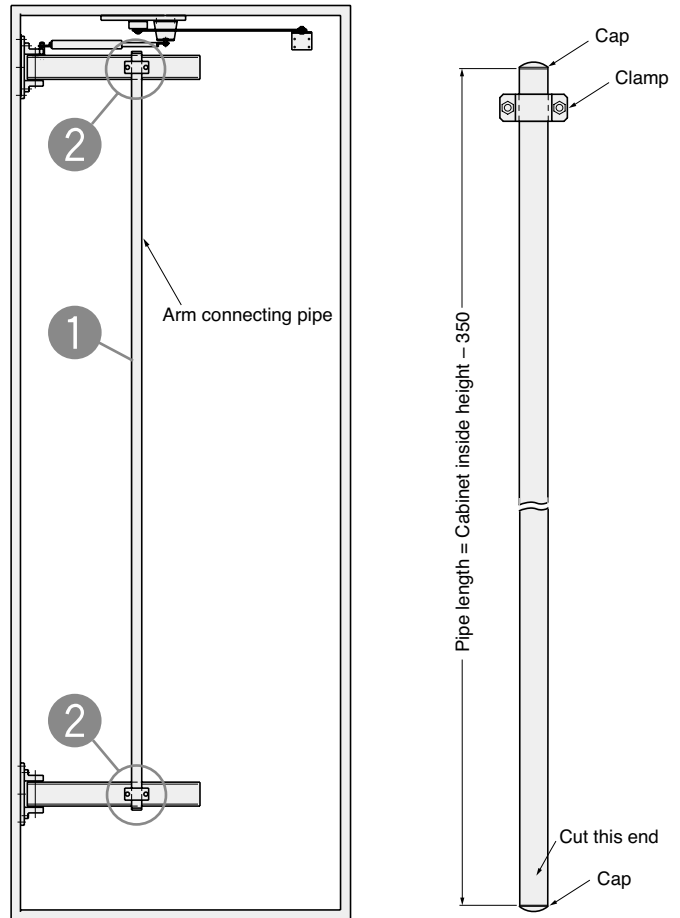

2 Installing arm connecting pipe

Attach the Connection pipe to the cutout part on both arms and fix it with the provided screws and flat washers.

Torque the screws step by step, in a criss-cross pattern, to prevent torsion of the pipe.

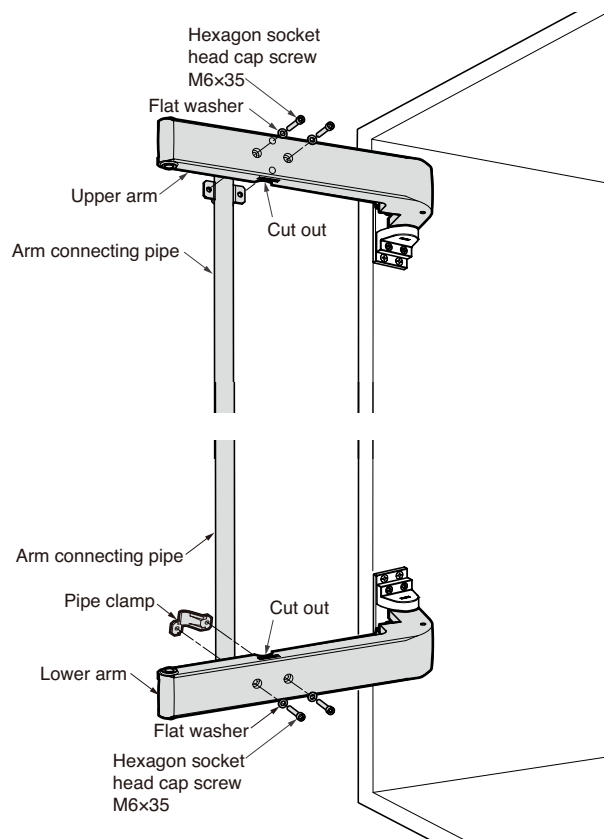

4 Installing Gas Spring

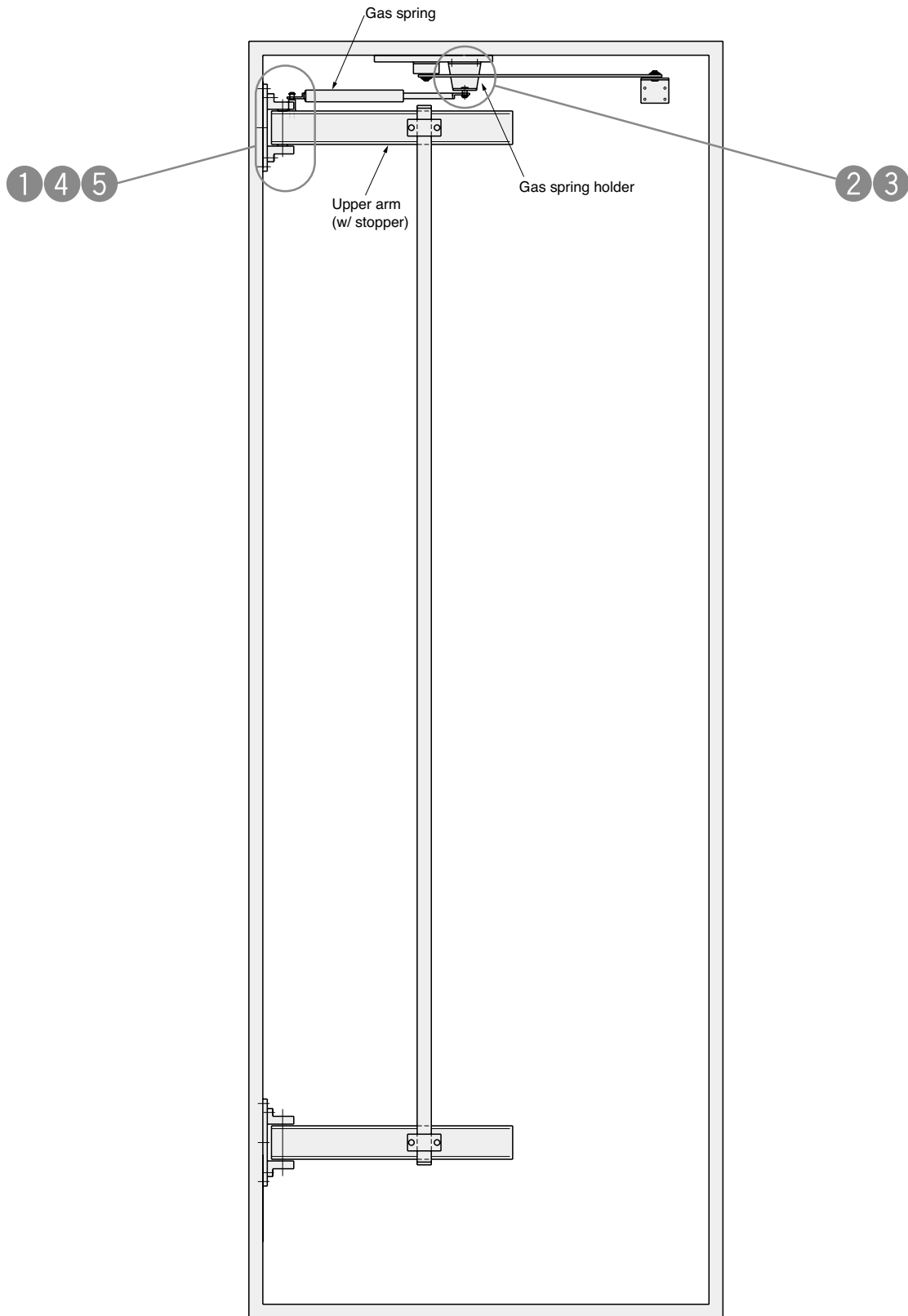

1 Installing Screw pin

Tighten the Screw pin firmly into the tapped hole on the top face of the Upper arm.

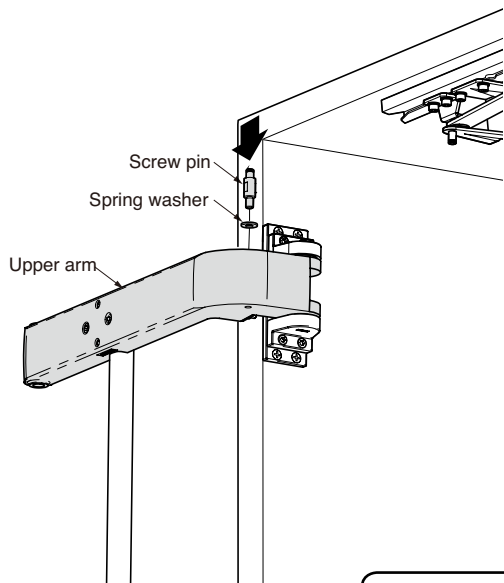

2 Fixing Gas spring (arm side)

Move the Upper arm to the full opening position where the stopper touches the side board, then assemble the Gas spring to the Screw pin as shown in the below figure.

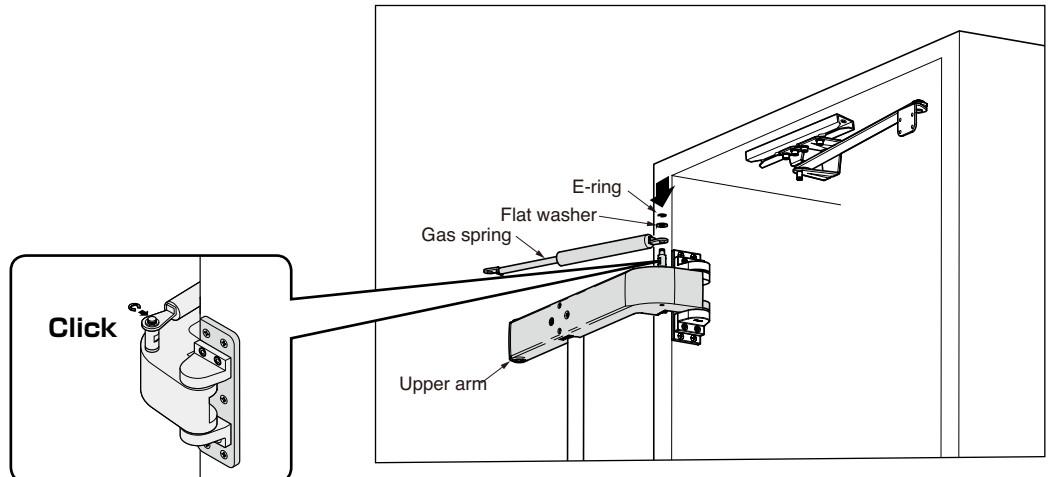
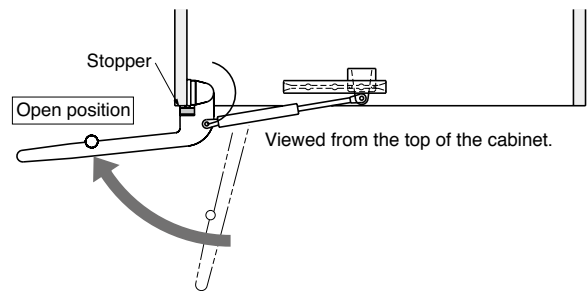

3 Fixing Gas spring (top board)

Loosen the screws on the Gas spring holder a little. Assemble the Gas spring to the Screw pin as shown in the below figure.

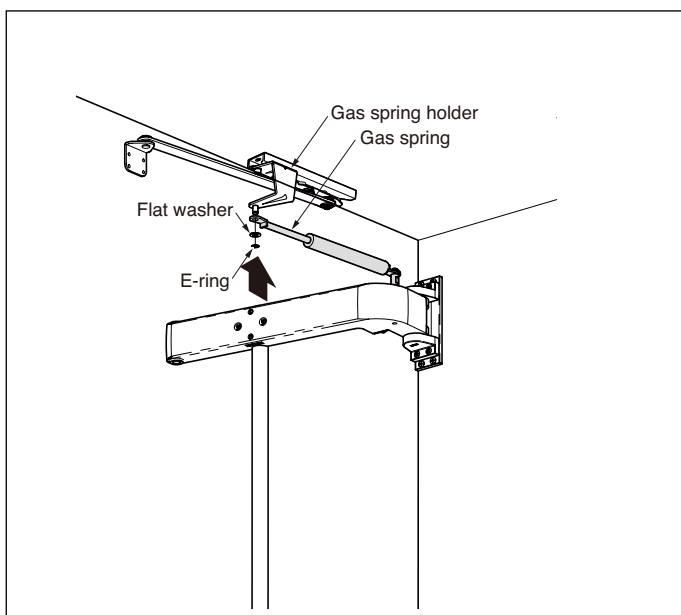

4 Fixing Gas spring holder

With Upper arm at the full opened position where the stopper touches the side board, tighten the screws on the Gas spring holder firmly.

5 Attaching Clear cushion rubber

Return the Upper arm to the closed position, then stick the Clear cushion rubber on the center of the Upper arm stopper.

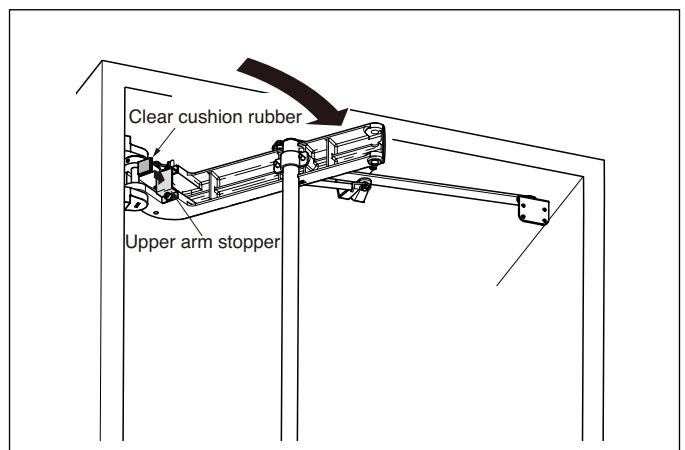

5 Installing parts to the door

1 Fixing Positioning unit

Mount the Positioning unit on the rear face of the door with the provided screws so that the LAMP logo can be seen properly.

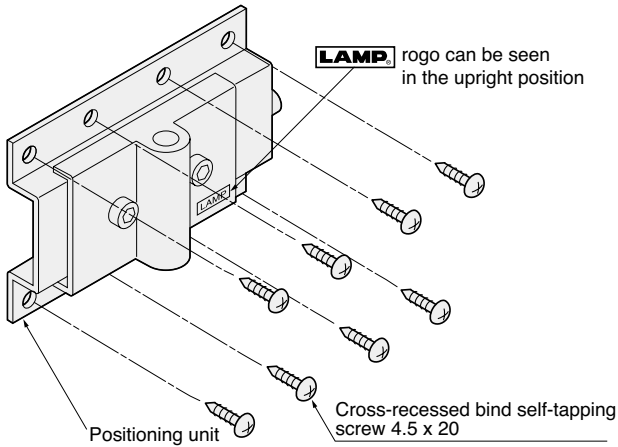

CAUTION

Set core material of which strength is enough for secure tightening of self-tapping screws to the locations that parts are to be installed.

Dimensions in lateral direction are determined with the (width) of the cabinet (wooden frame) regarded as the reference position. If the door end face is regarded as the reference position, add the overlaying allowance.

2 Sticking Brush seal

Stick the Brush seal to both edges on the rear face of the door.

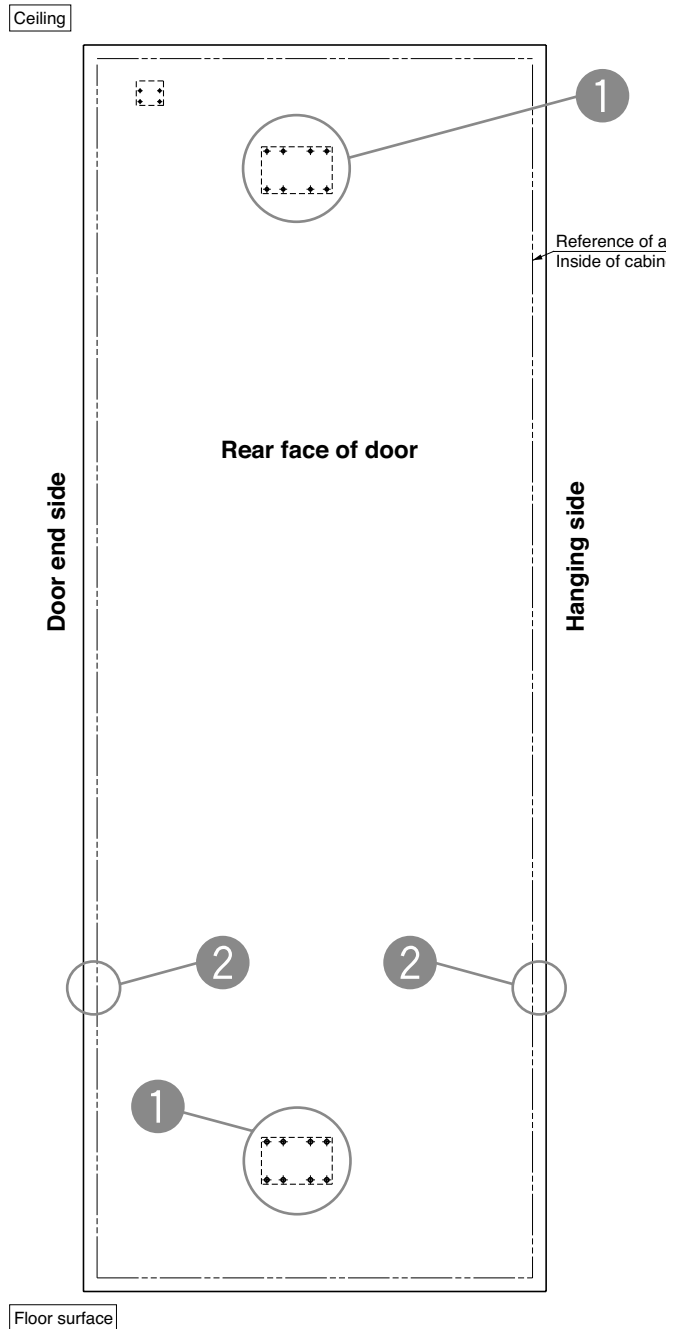
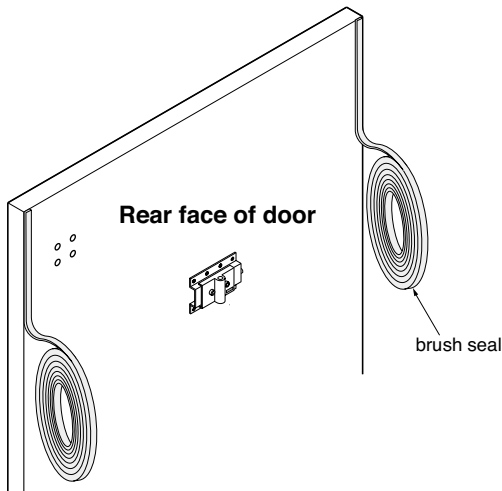

6 Installing door

1 Assembling Upper and Lower arms and Positioning unit

1. Open Upper and Lower arms to full opening position as below.
The figure shows the Upper arm from underneath.

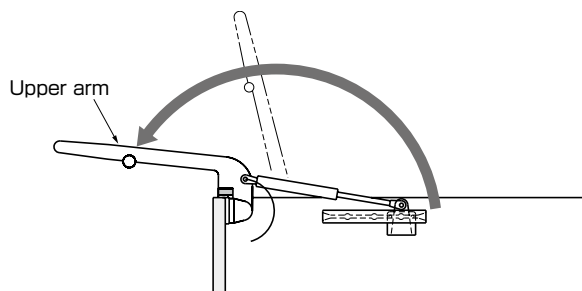

2. When hanging the door, place a support under the door.
This is to protect the door and roughly match the height of Upper and Lower arms and Positioning units.

3. Hang the door in the following manner.
 - (1) Tighten the horizontal positioning screws on the Upper and Lower positioning units.
 - (2) Align the top surfaces of the Upper and Lower positioning units on the door with the bottom surfaces of the Upper and Lower arms.
 - (3) Insert a hexagon head bolt into the connecting hole with the flat washer.
 - (4) Screw the hexagon head bolt into the positioning unit until its leading end protrudes by about 10 mm.
 - (5) Screw a hexagon nut into position until it touches the positioning unit.

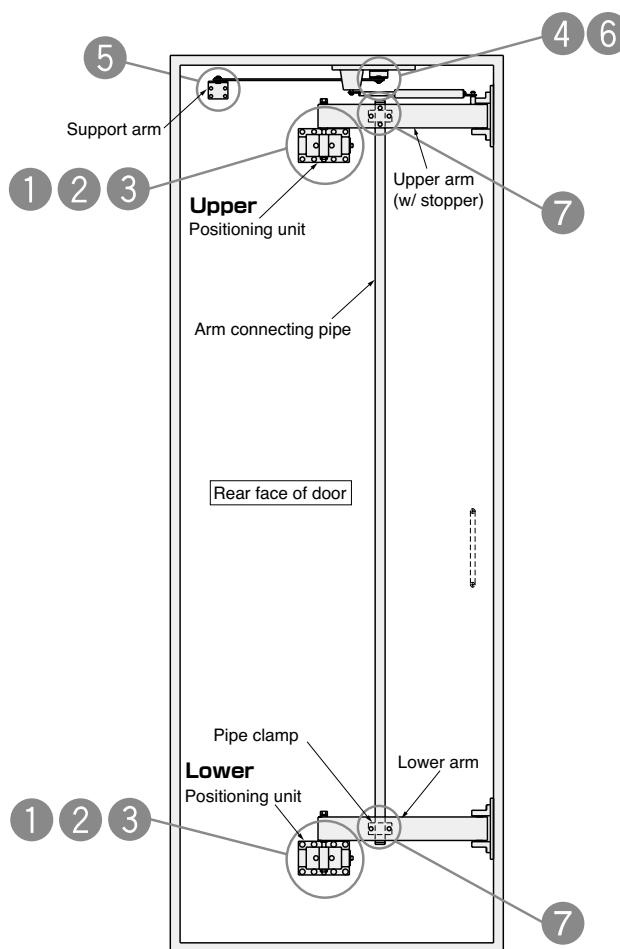

Back face of the door viewed from the inside of the cabinet

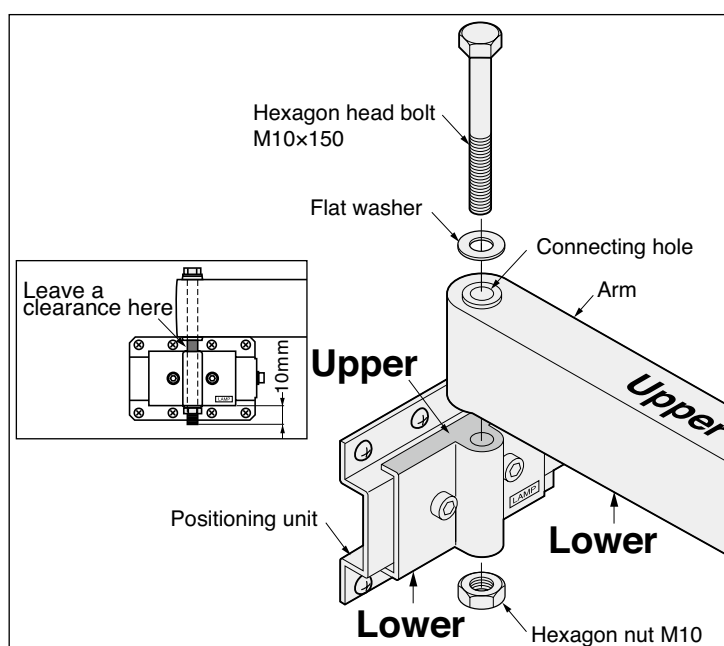

⚠ Caution

Assemble the Upper arm and Upper positioning unit first, then assemble the Lower arm and Lower positioning unit.



When positioning the door, be sure to loosen the hexagon socket head cap screw on the Support arm crank bracket (see P. 6 ④) to allow the bracket to move along the Channel rail.

② Vertical positioning of door

Be sure that the side board of the cabinet is assembled in a vertical direction.

1. Remove the support and close the door gently.
2. Measure the clearance between the top surface of the door and the top board.
 - (1) The difference between the planned dimension and the measurement is the required amount of adjustment.
 - (2) If there is no gap to correct, proceed to “③ Horizontal positioning of door.”
 - (3) Replace the support in the original position and open the door again.
 - Loosen the hexagon head bolt on the Upper and Lower arms a little.
 - Refer to the right figure and adjust the height. After the adjustment, turn the hexagon bolt on the Lower arm clockwise.
 - Close the door gently and check the height.
 - If the height is OK, tighten the hexagon nut.



Caution

Note that there should be no gap between the Hexagon bolt and washer for both Upper and Lower arms.

If any gap is found, tighten the Hexagon bolts so that the load on the two arms will be equal.

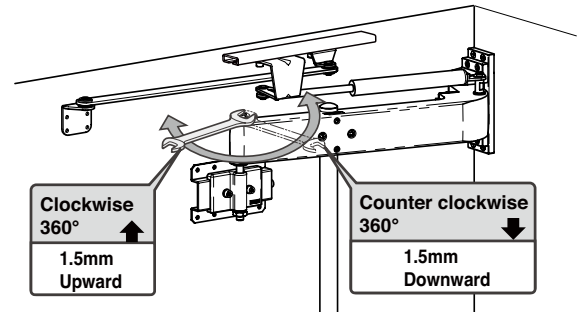
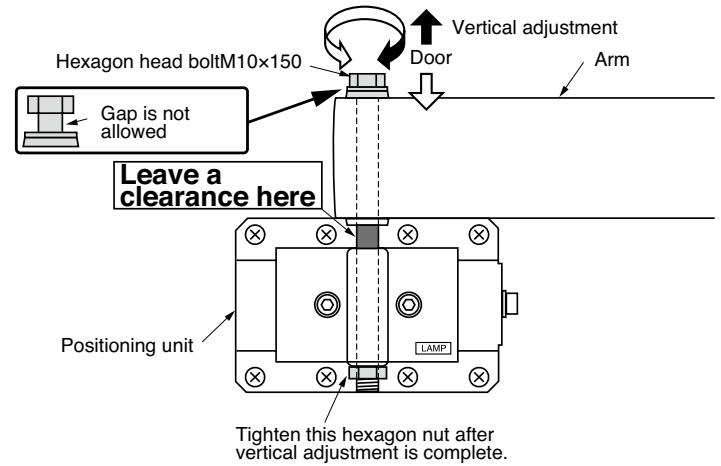

③ Horizontal positioning of door

1. Measure the horizontal gap between the door and cabinet. If there is any gap to be corrected, loosen the Hexagon socket head bolt on the Support arm crank bracket. (See P. 13 ④.)
2. Loosen the horizontal fixing screws on both Upper and Lower positioning units.
3. Turn the horizontal positioning screws.
 - (1) Turn the screws clockwise to move the door to the left or counterclockwise to move the door to the right when the door is viewed from the front.
 - (2) Retighten the positioning screws if the adjustment is OK.

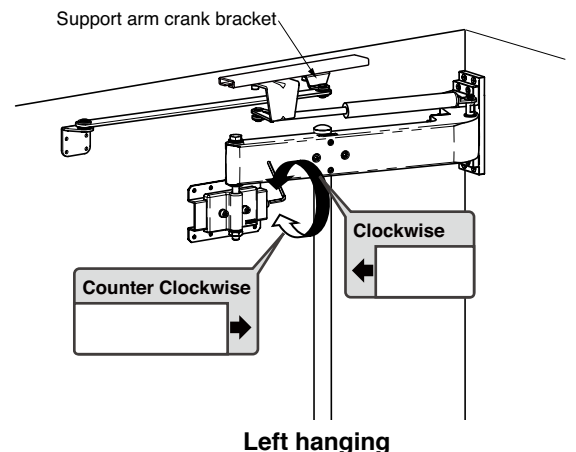
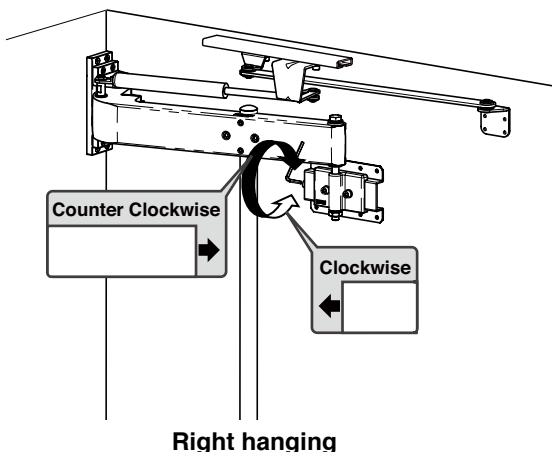
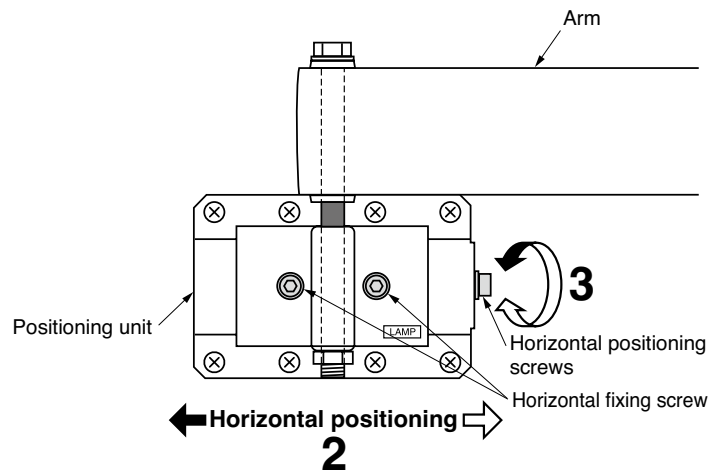

4 Release Support arm crank bracket.

Loosen the hexagon socket head cap screws on the Support arm crank bracket, and allow the bracket to move along the Channel rail.

5 Fixing Support arm

Close the door completely, and fix the Support arm L-type bracket to the door with provided screws.



Be sure to face the pin of the crank bracket to the rear of the cabinet.

6 Fix Support arm crank bracket.

Open the door slowly and fully and fix the Crank bracket.



When positioning the door, be sure to loosen the hexagon socket head cap screw on the Support arm crank bracket to allow the bracket to move along the Channel rail.

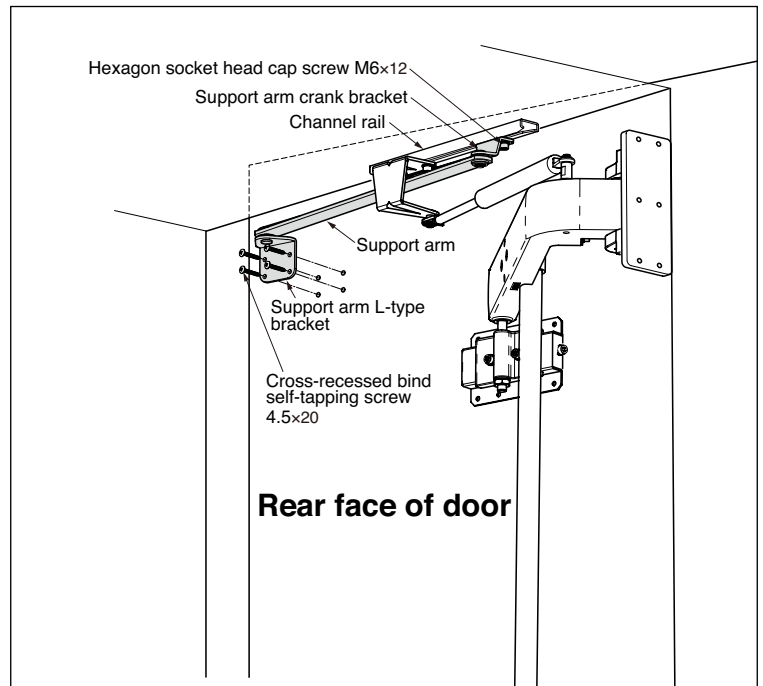

7 Adjusting the gap between the side board and door.

Loosen the screws on the Lower arm which fix the Arm connecting pipe. While keeping the door closed with no gap between the door and side board, retighten the screws. If there is any gap left, adjust it by referring to "7 Troubleshooting [4]".

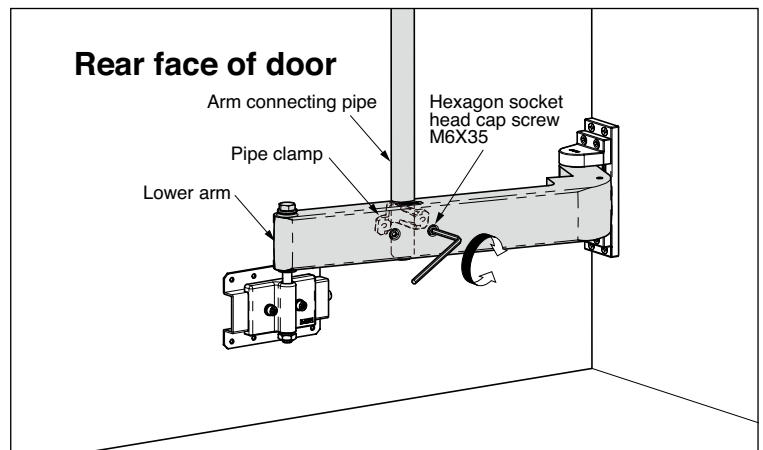

7

Troubleshooting

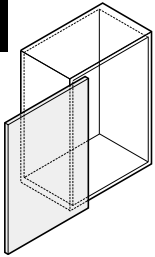

[1] Large friction sound when opening/closing door

Possible cause:

Positioning unit may touch the arm.

Solution:

Refer to P. 12 ② and make a clearance between the Positioning unit and arm.

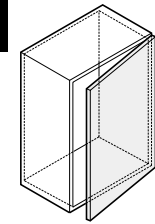
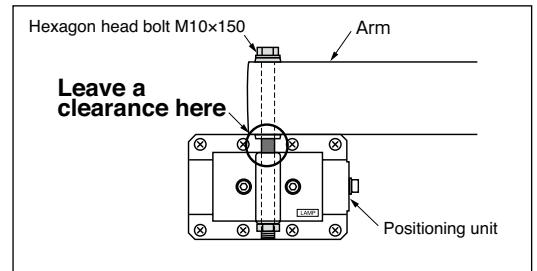

[2] A gap remains between the side board and the door (hanging side) or it takes a long time to be closed.

(1) In case of large gap

Possible cause:

The position of Crank bracket may be improper.

Solution:

Loosen the screws on the bracket and move the bracket to the door-end direction. Then re-tighten the screws. (See P. 12.)

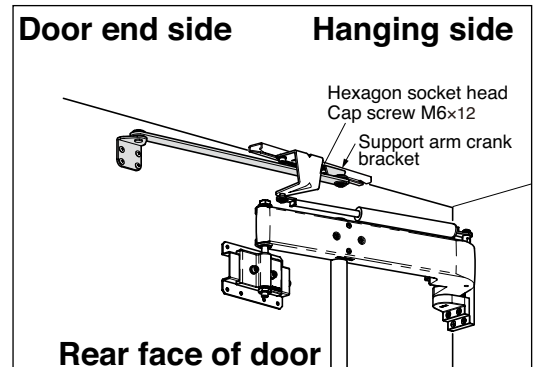

(2) In case of small gap

Possible cause:

Horizontal positioning of door may be improper.

Solution:

Loosen Horizontal fixing screws on the Positioning unit, then adjust the position by rotating the Horizontal positioning screw.

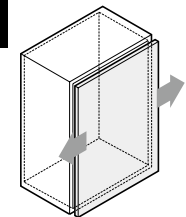
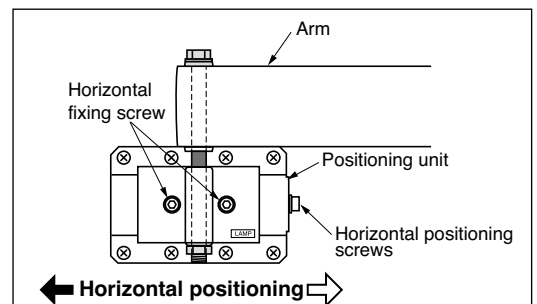

[3] Gap between door and cabinet varies after horizontal positioning

Solution:

Check the following in order.

(1) Vertical positioning, (2) Horizontal positioning (P.12), (3) Positioning of Crank bracket (P.13), and (4) Door close position adjuster screw A, B (P.15)

Possible cause;

If you adjust the vertical position or horizontal position in the last order, the gap between the door and cabinet may vary.

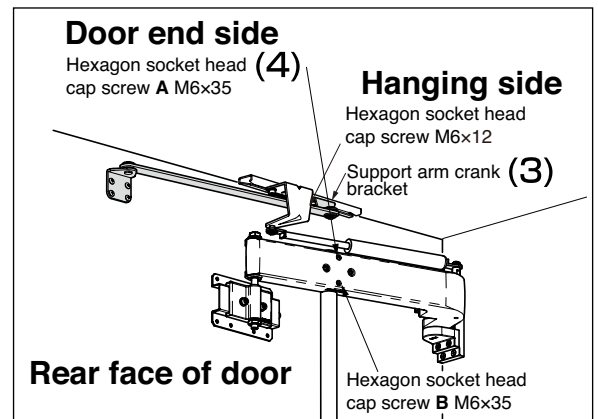
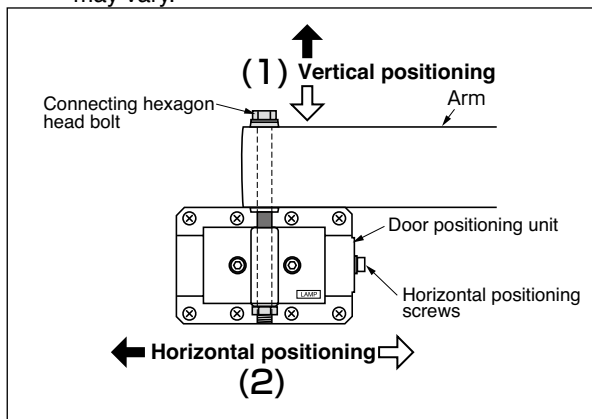

[4] Gap between door and cabinet still remains

Overview:

This system controls the slant of the door by bowing the Connecting pipe.
Simply try the following method unsuspectingly.

Release the stress on Connecting pipe by loosening the 4 pcs of Hexagon socket head cap screws.

*Also, loosen Door close position adjuster screw A and B, so that it make a clearance between the Upper arm and the Connecting pipe.

*Adjustment need to be done from inside the cabinet at the closed door.

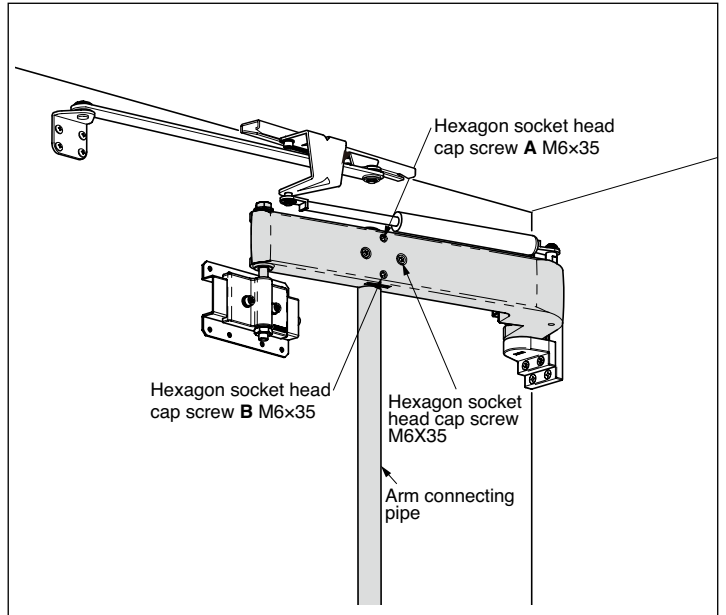

Tighten the Hexagon socket head cap screws on Lower arm. Adjustment would not be achieved if the screws on Lower arm were loose.

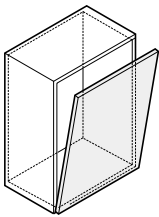

Gap at the top

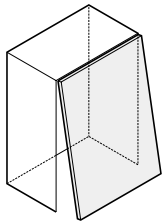
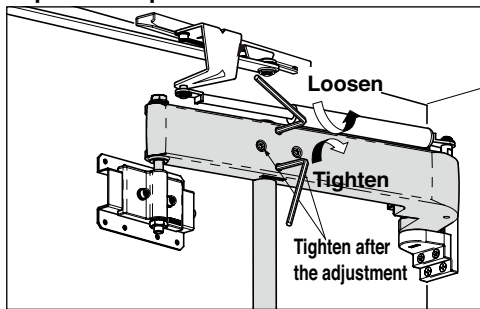

Gap at the bottom

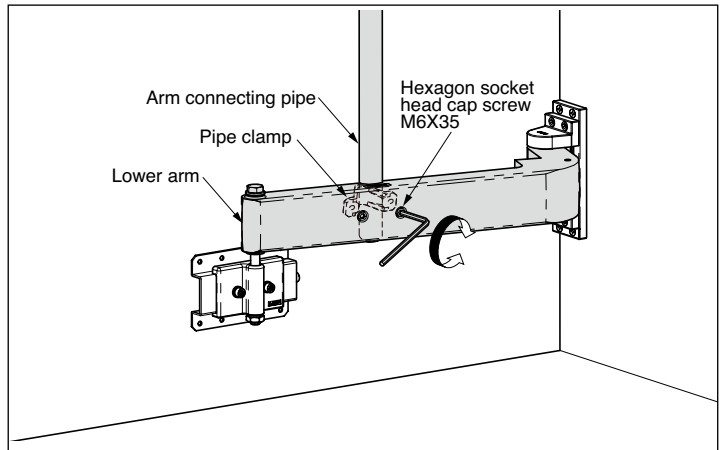
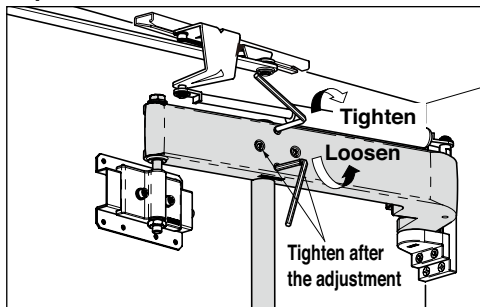

In case the gap still remains, even if the Connecting pipe is 7 or 8 mm apart from Upper arm, once loosen the Door position adjuster screw A and B completely, then tighten them until the Connecting pipe touches Upper arm. (See below figure.)

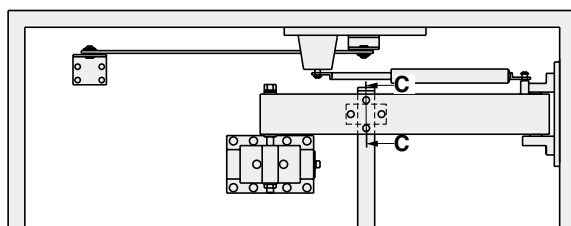

Cross section C-C

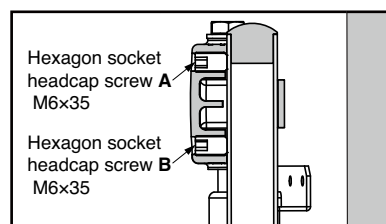

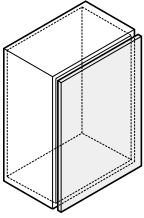

[5] There are gaps on all four corners

Possible cause:

Large doors are likely to warp, and perfect adjustment is not possible in case of a large warp.

Adjust the gap between the door and the cabinet by attaching either the Brush seal or alternatively use "BS Bumpers" (sold separately).

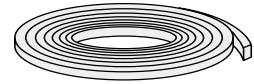

Brush seal
FAD-44 : (5000mm)×1
FAD-44L : (6000mm)×1

In case the door bows inward.
It is not possible to make more than 2 corners to be contacted.

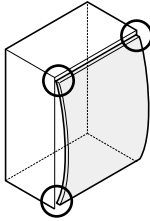

In case the door bows outward.
It is not possible to make more than a corner to be contacted.

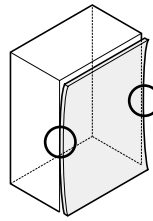

BS Bumpers(sold separately)
You can choose various thickness.

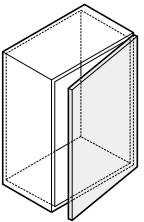

[6] Out of alignment after using

Possible cause:

The position of the handle may be improper.

The arm may be bent or out of alignment due to improper opening force if the handle is located far from the Hanging side.

Try the alignment.

If the parts are damaged. Contact us.

SUGATSUNE KOGYO CO.,LTD.
Phone: +81 3 3866 2260
F a x : +81 3 3866 4447
E-mail: export@sugatsune.co.jp
Website: www.sugatsune-intl.com

SUGATSUNE KOGYO (UK) LTD.
Phone: +44 118 9272 955
F a x : +44 118 9272 871
E-mail: sales@sugatsune.co.uk
Website: www.sugatsune.co.uk

SUGATSUNE AMERICA, INC.
Phone: +1 310 329 6373
F a x : +1 310 329 0819
E-mail: sales@sugatsune.com
Website: www.sugatsune.com

SUGATSUNE SHANGHAI CO., LTD.
Phone: +86 21 3632 1858
F a x : +86 21 3632 1868
E-mail: lamp@sugatsune.com.cn
Website: www.sugatsune.com.cn