

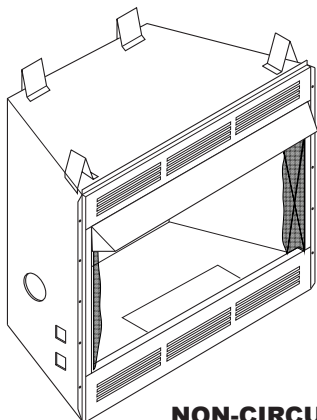

**UNVENTED (VENT-FREE)
UNIVERSAL FIREBOX
OWNER'S OPERATION AND
INSTALLATION MANUAL**



**NON-CIRCULATING MODELS
BV36(B), VBV36, BV42(B) AND VBV42
CIRCULATING MODELS
BV36L(B), VBV36L, BV42L(B) AND VBV42L**

⚠ WARNING: If the information in this manual is not followed exactly, a fire or explosion may result causing property damage, personal injury or loss of life.

FOR USE ONLY WITH A LISTED GAS-FIRED UNVENTED DECORATIVE ROOM HEATER NOT TO EXCEED 40,000 BTU/HR. DO NOT BUILD A WOOD FIRE.

Carefully review the instructions supplied with the decorative type unvented room heater for the minimum fireplace size requirement.

DO NOT INSTALL AN APPLIANCE IN THIS FIREBOX UNLESS THIS FIREBOX MEETS THE MINIMUM DIMENSIONS REQUIRED FOR THE INSTALLATION.

This firebox has been tested and approved under ANSI Z21.91 for use with any ANSI Z21.11.2 approved gas logs.

INSTALLER: Leave this manual with the appliance.
CONSUMER: Retain this manual for future reference.

TABLE OF CONTENTS

Safety	2	Installation	7
Local Codes.....	3	Parts	12
Product Features.....	3	Replacement Parts.....	14
Locating Firebox.....	4	Technical Service.....	14
Product Specifications.....	4	Accessories	14
Air For Combustion and Ventilation.....	5	Warranty.....	Back Cover

SAFETY

⚠ WARNING: Improper installation, adjustment, alteration, service or maintenance can cause injury or property damage. Refer to this manual for correct installation and operational procedures. For assistance or additional information consult a qualified installer, service agency or the gas supplier.

This appliance may be installed in an aftermarket,* permanently located, manufactured (mobile) home, where not prohibited by local codes.

* Aftermarket: Completion of sale, not for purpose of resale, from the manufacturer.

State of Massachusetts: The installation must be made by a licensed plumber or gas fitter in the Commonwealth of Massachusetts.

Sellers of unvented propane or natural gas-fired supplemental room heaters shall provide to each purchaser a copy of 527 CMR 30 upon sale of the unit.

Vent-free gas products are prohibited for bedroom and bathroom installation in the Commonwealth of Massachusetts.

⚠ WARNING: This product contains and/or generates chemicals known to the state of California to cause cancer or birth defects or other reproductive harm.

IMPORTANT: Read this owner's manual carefully and completely before trying to assemble, operate or service this heater. Improper use of this fireplace can cause serious injury or death from burns, fire, explosion, electrical shock and carbon monoxide poisoning.

⚠ WARNING: Any change to this firebox or its controls can be dangerous.

⚠ WARNING: Do not allow fans to blow directly into the firebox. Avoid any drafts that alter burner flame patterns. Ceiling fans can create drafts that alter burner flame patterns. Altered burner patterns can cause sooting.

⚠ WARNING: Do not use a blower insert, heat exchanger insert or other accessory not approved for use with this firebox.

SAFETY

Continued

Do not place clothing or other flammable material on or near the appliance. Never place any objects in the firebox or on logs.

Firebox front and screen become very hot when running heater. Keep children and adults away from hot surface to avoid burns or clothing ignition. Firebox will remain hot for a time after shutdown. Allow surface to cool before touching.

Carefully supervise young children when they are in the room with firebox.

You must operate this fireplace with the provided fireplace screen, hood if provided, in place. Make sure these parts are in place and screens are closed before running firebox. The supplied hood may not be replaced with a hood which may be provided with a log heater.

Keep the fireplace area clear and free from combustible materials, gasoline and other flammable vapors and liquids.

1. Do not use this firebox as a wood-burning fireplace. Use only decorative unvented room heaters (log sets).
2. Do not add extra logs or ornaments such as pine cones, vermiculite or rock wool. Using these added items can cause sooting.
3. Use only provided hood.
4. Vent-free gas log heaters installed in these fireboxes require fresh air ventilation to run properly. See *Air for Combustion and Ventilation*, page 5.
5. Do not run firebox
 - where flammable liquids or vapors are used or stored
 - under dusty conditions
6. Do not use this firebox to cook food or burn paper or other objects.
7. Turn firebox off and let cool before servicing. Only a qualified service person should service and repair firebox.
8. Operating firebox above elevations of 4,500 feet could cause pilot outage.
9. Do not use firebox if it has been under water due to shock hazard that could result with the blower accessory (if installed) in place.

LOCAL CODES

Install and use heater with care. Follow all local codes. In the absence of local codes, use the latest edition of *The National Fuel Gas Code, ANSI Z223.1/NFPA 54**. Firebox must be electrically grounded in accordance with the *National Electrical Code, ANSI/NFPA70* (latest edition).

*Available from:

American National Standards Institute, Inc.
1430 Broadway
New York, NY 10018

National Fire Protection Association, Inc.
Batterymarch Park
Quincy, MA 02269

PRODUCT FEATURES

OPERATION

This firebox is designed for use with approved ANSI Z21.11.2 decorative type unvented room heaters. (Physical size limitations apply. Refer to minimum firebox requirements supplied with log heater.) It requires no outside venting or chimney making installation easy and inexpensive. This firebox requires no electricity making it ideal for emergency backup heat.

OUTSIDE AIR KIT ACCESSORY

The optional AK4 air kit provides additional outdoor air to improve burner efficiency and reduce build-up of condensation in living space. Follow instructions included with air kit.

LOCATING FIREBOX

PLANNING

Plan where you will install the firebox. This will save time and money later when you install the firebox. Before installation, consider the following:

1. Where the firebox will be located. Allow for wall and ceiling clearances (see *Installation Clearances*, page 8).

2. Everything needed to complete installation.
3. These models CANNOT be installed in a bedroom unless the maximum Btu rating of the installed vent-free log set is less than 10,000 Btu/hr.
4. Proper air for combustion and ventilation (page 6).

PRODUCT SPECIFICATIONS

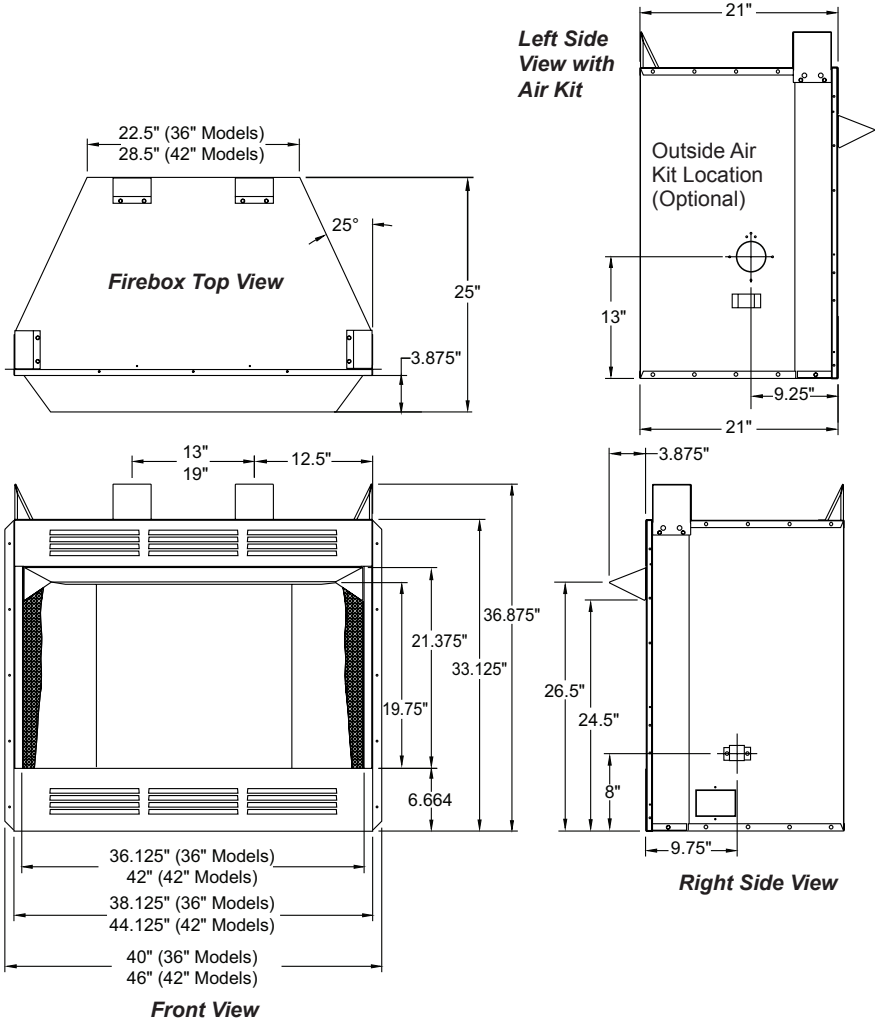

Figure 1 - Firebox Dimensions

AIR FOR COMBUSTION AND VENTILATION

⚠ WARNING: This heater shall not be installed in a room or space unless the required volume of indoor combustion air is provided by the method described in the *National Fuel Gas Code, ANSI Z223.1/NFPA 54*, the *International Fuel Gas Code*, or applicable local codes. Read the following instructions to insure proper fresh air for this and other fuel-burning appliances in your home.

Today's homes are built more energy efficient than ever. New materials, increased insulation and new construction methods help reduce heat loss in homes. Home owners weather strip and caulk around windows and doors to keep the cold air out and the warm air in. During heating months, home owners want their homes as airtight as possible.

While it is good to make your home energy efficient, your home needs to breathe. Fresh air must enter your home. All fuel-burning appliances need fresh air for proper combustion and ventilation.

Exhaust fans, fireboxes, clothes dryers and fuel burning appliances draw air from the house to operate. You must provide adequate fresh air for these appliances. This will insure proper venting of vented fuel-burning appliances.

PROVIDING ADEQUATE VENTILATION

The following are excerpts from *National Fuel Gas Code, ANSI Z223.1/NFPA 54, Air for Combustion and Ventilation*.

All spaces in homes fall into one of the three following ventilation classifications:

1. Unusually Tight Construction
2. Unconfined Space
3. Confined Space

The information on page 5 through 7 will help you classify your space and provide adequate ventilation.

Unusually Tight Construction

The air that leaks around doors and windows may provide enough fresh air for combustion and ventilation. However, in buildings of unusually tight construction, you must provide additional fresh air.

Unusually tight construction is defined as construction where:

- a. walls and ceilings exposed to the outside atmosphere have a continuous water vapor retarder with a rating of one perm (6×10^{-11} kg per pa-sec- m^2) or less with openings gasketed or sealed and
- b. weather stripping has been added on openable windows and doors and
- c. caulking or sealants are applied to areas such as joints around window and door frames, between sole plates and floors, between wall-ceiling joints, between wall panels, at penetrations for plumbing, electrical and gas lines and at other openings.

If your home meets all of the three criteria above, you must provide additional fresh air. See [Ventilation Air From Outdoors](#), page 7.

If your home does not meet all of the three criteria above, proceed to [Determining Fresh-Air Flow for Firebox Location](#), page 6.

Confined and Unconfined Space

The *National Fuel Gas Code, ANSI Z223.1/NFPA 54* defines a confined space as a space whose volume is less than 50 cubic feet per 1,000 Btu per hour (4.8 m^3 per kw) of the aggregate input rating of all appliances installed in that space and an unconfined space as a space whose volume is not less than 50 cubic feet per 1,000 Btu per hour (4.8 m^3 per kw) of the aggregate input rating of all appliances installed in that space. Rooms communicating directly with the space in which the appliances are installed*, through openings not furnished with doors, are considered a part of the unconfined space.

* Adjoining rooms are communicating only if there are doorless passageways or ventilation grills between them.

AIR FOR COMBUSTION AND VENTILATION

Continued

DETERMINING FRESH-AIR FLOW FOR HEATER LOCATION

Determining if You Have a Confined or Unconfined Space

Use this work sheet to determine if you have a confined or unconfined space.

Space: Includes the room in which you will install heater plus any adjoining rooms with doorless passageways or ventilation grills between the rooms.

1. Determine the volume of the space (length x width x height).

Length x Width x Height = _____ cu. ft. (volume of space)

Example: Space size 22 ft. (length) x 18 ft. (width) x 8 ft. (ceiling height) = 3168 cu. ft. (volume of space)

If additional ventilation to adjoining room is supplied with grills or openings, add the volume of these rooms to the total volume of the space.

2. Multiply the space volume by 20 to determine the maximum Btu/Hr the space can support.

_____ (volume of space) x 20 = (Maximum Btu/Hr the space can support)

Example: 3168 cu. ft. (volume of space) x 20 = 63,360 (maximum Btu/Hr the space can support)

3. Add the Btu/Hr of all fuel burning appliances in the space.

Vent-free heater	_____	Btu/Hr
Gas water heater*	_____	Btu/Hr
Gas furnace	_____	Btu/Hr
Vented gas heater	_____	Btu/Hr
Gas fireplace logs	_____	Btu/Hr
Other gas appliances* +	_____	Btu/Hr
Total	= _____	Btu/Hr

* Do not include direct-vent gas appliances. Direct-vent draws combustion air from the outdoors and vents to the outdoors.

Example:

Gas water heater	_____	40,000	Btu/Hr
Vent-free heater	+ _____	39,000	Btu/Hr
Total	= _____	79,000	Btu/Hr

4. Compare the maximum Btu/Hr the space can support with the actual amount of Btu/Hr used.

_____ Btu/Hr (maximum the space can support)

_____ Btu/Hr (actual amount of Btu/Hr used)

Example: 63,360 Btu/Hr (maximum the space can support)

79,000 Btu/Hr (actual amount of Btu/Hr used)

The space in the above example is a confined space because the actual Btu/Hr used is more than the maximum Btu/Hr the space can support. You must provide additional fresh air. Your options are as follows:

- A. Rework worksheet, adding the space of an adjoining room. If the extra space provides an unconfined space, remove door to adjoining room or add ventilation grills between rooms. See *Ventilation Air From Inside Building*, page 7.
- B. Vent room directly to the outdoors. See *Ventilation Air From Outdoors*, page 7.
- C. Install a lower Btu/Hr heater, if lower Btu/Hr size makes room unconfined.

If the actual Btu/Hr used is less than the maximum Btu/Hr the space can support, the space is an unconfined space. You will need no additional fresh air ventilation.

⚠ WARNING: If the area in which the heater may be operated does not meet the required volume for indoor combustion air, combustion and ventilation air shall be provided by one of the methods described in the *National Fuel Gas Code, ANSI Z223.1/NFPA 54, the International Fuel Gas Code, or applicable local codes.*

AIR FOR COMBUSTION AND VENTILATION

Continued

VENTILATION AIR

Ventilation Air From Inside Building

This fresh air would come from an adjoining unconfined space. When ventilating to an adjoining unconfined space, you must provide two permanent openings: one within 12" of the ceiling and one within 12" of the floor on the wall connecting the two spaces (see options 1 and 2, Figure 2). You can also remove door into adjoining room (see option 3, Figure 3). Follow the *National Fuel Gas Code, ANSI Z223.1/NFPA 54, Air for Combustion and Ventilation* for required size of ventilation grills or ducts.

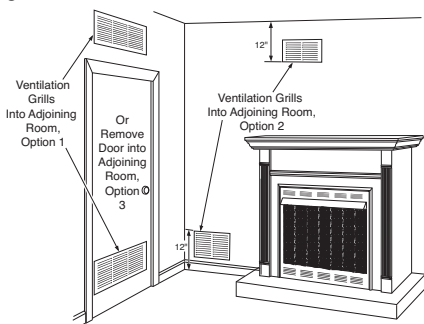

Figure 2 - Ventilation Air from Inside Building

Ventilation Air From Outdoors

Provide extra fresh air by using ventilation grills or ducts. You must provide two permanent openings: one within 12" of the ceiling and one within 12" of the floor. Connect these items directly to the outdoors or spaces open to the outdoors. These spaces include attics and crawl spaces. Follow the *National Fuel Gas Code, ANSI Z223.1/NFPA 54, Air for Combustion and Ventilation* for required size of ventilation grills or ducts.

IMPORTANT: Do not provide openings for inlet or outlet air into attic if attic has a thermostat-controlled power vent. Heated air entering the attic will activate the power vent.

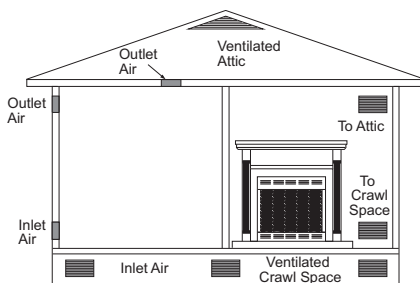

Figure 3 - Ventilation Air from Outdoors

INSTALLATION

WARNING: A qualified service person must install firebox. Follow all local codes.

WARNING: Never install the firebox

- in a bedroom or bathroom*
- in a recreational vehicle
- where curtains, furniture, clothing or other flammable objects are less than 42" from the front, top or sides of the firebox
- in high traffic areas
- in windy or drafty areas

* Unless the installed log set is rated at 10,000 Btu/Hr or less in a bedroom or 6,000 Btu/Hr or less in a bathroom.

CAUTION: Log heaters installed in this firebox create warm air currents. These currents move heat to wall surfaces next to firebox. Installing firebox next to vinyl or cloth wall coverings or operating firebox where impurities (such as, but not limited to, tobacco smoke, aromatic candles, cleaning fluids, oil or kerosene lamps, etc.) in the air exist, may discolor walls or cause odors.

INSTALLATION

Continued

IMPORTANT: Vent-free gas log heaters add moisture to the air. Although this is beneficial, installing firebox in rooms without enough ventilation air may cause mildew to form from too much moisture. See [Air for Combustion and Ventilation](#), page 5.

IMPORTANT: Make sure firebox is level. If firebox is not level, log set will not work properly.

Note: Your firebox is designed to be used in zero clearance installations. Wall or framing material can be placed against any exterior surface on the rear, sides, top or bottom of your firebox, except where standoff spacers are integrally attached. If standoff spacers are attached to your firebox, these spacers can be placed directly against wall or framing materials. Use the dimensions shown for rough opening to create the easiest installation.

Use dimensions shown for rough openings to create the easiest installation (see [Built-In Firebox Installation](#), page 9).

INSTALLATION CLEARANCES

WARNING: Maintain the minimum clearances. If you can, provide greater clearances from floor, ceiling and adjoining wall.

Carefully follow these instructions. This will ensure safe installation.

Minimum Wall and Ceiling Clearances (see Figure 4)

- Clearances from the side of fireplace cabinet to any combustible material and wall should follow diagram in Figure 4.
Example: The face of a mantel, bookshelf, etc. is made of combustible material and protrudes 3 1/2" from the wall. This combustible material must be 4" from the side of the fireplace cabinet (see Figure 4).
- Clearances from the top of firebox opening to ceiling should not be less than 42".
- When firebox is installed on carpeting or other combustible material, other than wood flooring, firebox should be installed on a metal or wood panel extending the full width and depth of enclosure.
- Clearances from bottom of firebox to the floor is 0".

These fireboxes can be installed as freestanding units against a wall with the approved, optional cabinet mantels (see [Accessories](#), page 14) or as a built-in unit. Clearances are the same for either installation method.

CAUTION: Do not install firebox directly on carpet or vinyl.

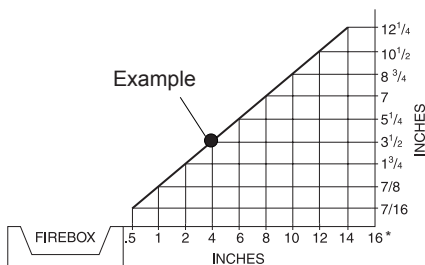

*Minimum 16" from Side Wall

Figure 4 - Minimum Clearance for Combustible to Wall

Mantel Clearances for Built-In Installation

If placing custom mantel above built-in firebox, you must meet the minimum allowable clearance between mantel shelf and top of firebox opening shown in Figure 5, page 9. These are the minimum allowable mantel clearances for a safe installation. Use larger clearances whenever possible to minimize the heating of objects and materials placed on the mantel.

CAUTION: Do not allow the vent-free gas log heater to touch or extend beyond the fireplace screen.

NOTICE: Surface temperatures of adjacent walls and mantels become hot during operation. Walls and mantels above the firebox may become hot to the touch. If installed properly, these temperatures meet the requirement of the national product standard. Follow all minimum clearances shown in this manual.

NOTICE: If your installation does not meet the minimum clearances shown, you must do one of the following:

- raise the mantel to an acceptable height
- remove the mantel

INSTALLATION

Continued

BUILT-IN FIREBOX INSTALLATION

Built-in installation of this firebox involves installing firebox into a framed-in enclosure. This makes the front of firebox flush with wall. Optional brass trim accessories are available (see *Accessories*, page 14). The brass trim will extend past sides of firebox approximately 1/2". This will cover the rough edges of the wall opening. If installing a mantel above the firebox, you must follow the clearances shown in Figure 5. Follow the instructions below to install the firebox in this manner.

1. Frame in rough opening. The firebox framing should be constructed of 2 x 4 lumber or heavier. Use dimensions in the table and rough opening layout in Figure 6a. Adjust framing so that firebox flushes with finished wall surface. If installing in a corner, use dimensions in Figures 6b for rough opening.
2. Install gas piping to firebox location. See *Installing Gas Line*, page 10 and *Connecting to Gas Supply* in log set owner's manual.
3. Carefully set firebox in front of rough opening with back of firebox inside wall opening. **IMPORTANT:** If installing a perimeter trim kit, see instructions included with trim accessory. You must install shoulder screws from trim kit now.
4. Carefully insert firebox into rough opening.

5. Attach firebox to wall studs using nails or wood screws through holes in nailing flange (see Figure 7, page 10).
6. If using an optional perimeter trim kit, install the trim after final finishing and/or painting of wall. See instructions included with trim accessory for attaching trim.
7. Install and properly test gas log heater. Follow installation instructions included with the vent-free gas log heater that is being installed.

IMPORTANT: When finishing your firebox, combustible materials such as wall board, gypsum board, sheet rock, drywall, plywood, etc. may be butted up next to the sides and top of the firebox. Combustible materials should never overlap the firebox front facing.

Rough Opening Dimensions for Built-in Installation			
Model	Front Width (Inside to Inside)	Height	Depth (Min.)
36"	38 1/4"	37 5/8"	22"
42"	44 1/4"	37 5/8"	22"

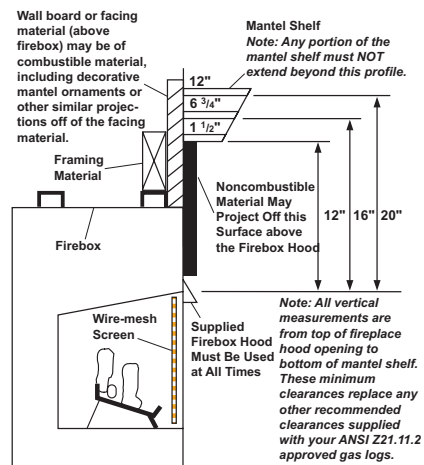

Figure 5 - Minimum Mantel Clearances for Built-In Installation

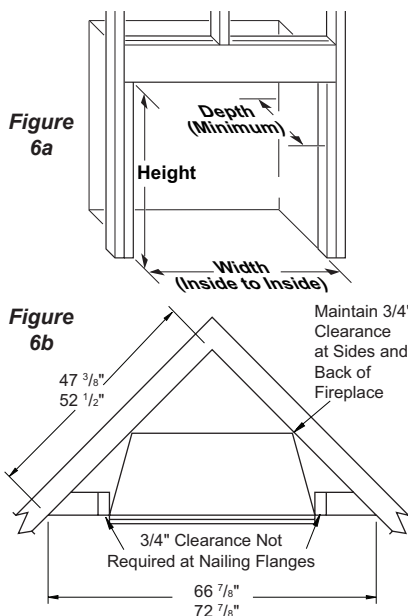

Figure 6 - Rough Opening for Installing in Wall

INSTALLATION

Continued

⚠ WARNING: Do not allow any combustible materials to overlap the firebox front facing.

IMPORTANT: Noncombustible materials such as brick, tile, etc. may overlap the front facing, but should never cover any necessary openings like louvered slots.

⚠ WARNING: Do not allow noncombustible materials to cover any necessary openings like louvered slots.

⚠ WARNING: Use only non-combustible mortar or adhesives when overlapping the front facing with noncombustible facing material.

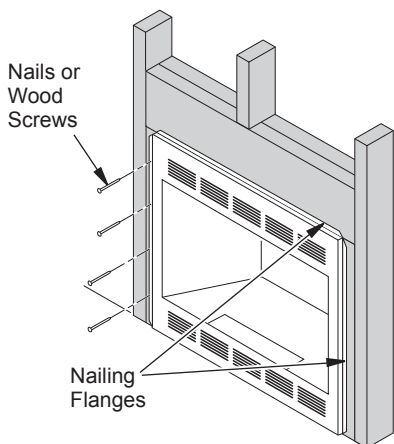

Figure 7 - Attaching Firebox to Wall Studs

INSTALLING FIREBOX USING OPTIONAL ACCESSORY MANTELS

⚠ WARNING: A qualified service person must install firebox. Follow all local codes.

This firebox may be installed using a cabinet mantel accessory against a wall in your home. The firebox and cabinet mantel can be installed directly on the floor. A trim kit is included with the mantel accessories. Follow instructions with mantel for installation.

INSTALLING GAS LINE

NOTICE: A qualified service person must connect heater to gas supply. Follow all local codes.

IMPORTANT: See *Connecting to Gas Supply* in your log set owner's manual for details on gas hookup.

You may run the gas line from either side of the firebox (see Figure 9). Decide which side you want to run the gas line from.

Note: This is one option for installing shutoff valve. Check local codes for equipment shutoff valve location requirements.

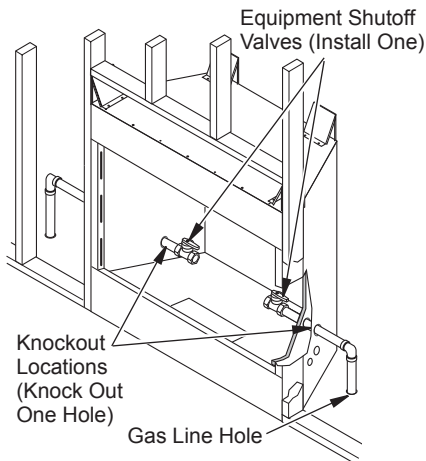

Figure 8 - Installing Gas Line and Equipment Shutoff Valve (Model May Vary From Illustration)

INSTALLATION

Continued

USING OPTIONAL FIBER PANELS

There is a gas knockout in each side panel for the gas line to feed through. Determine on which side the gas connection will be located. Using a utility knife or cutting blade, remove the identified gas knockout.

⚠ CAUTION: Do not use excessive force to remove the knockout. Too much force may damage the fiber panel.

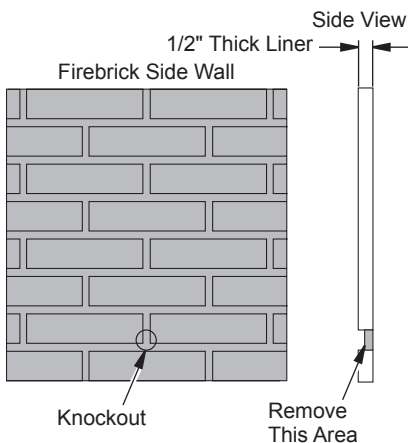

Figure 9 - Location of Knockout for Gas Line

INSTALLING FIREPLACE HOOD

Attach hood to firebox using screws provided (see Figure 10).

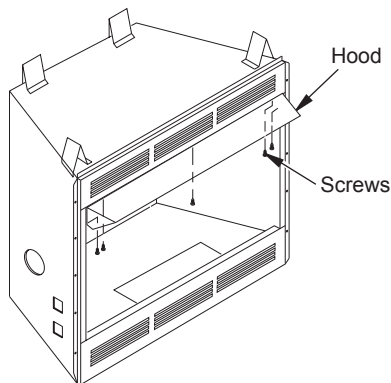
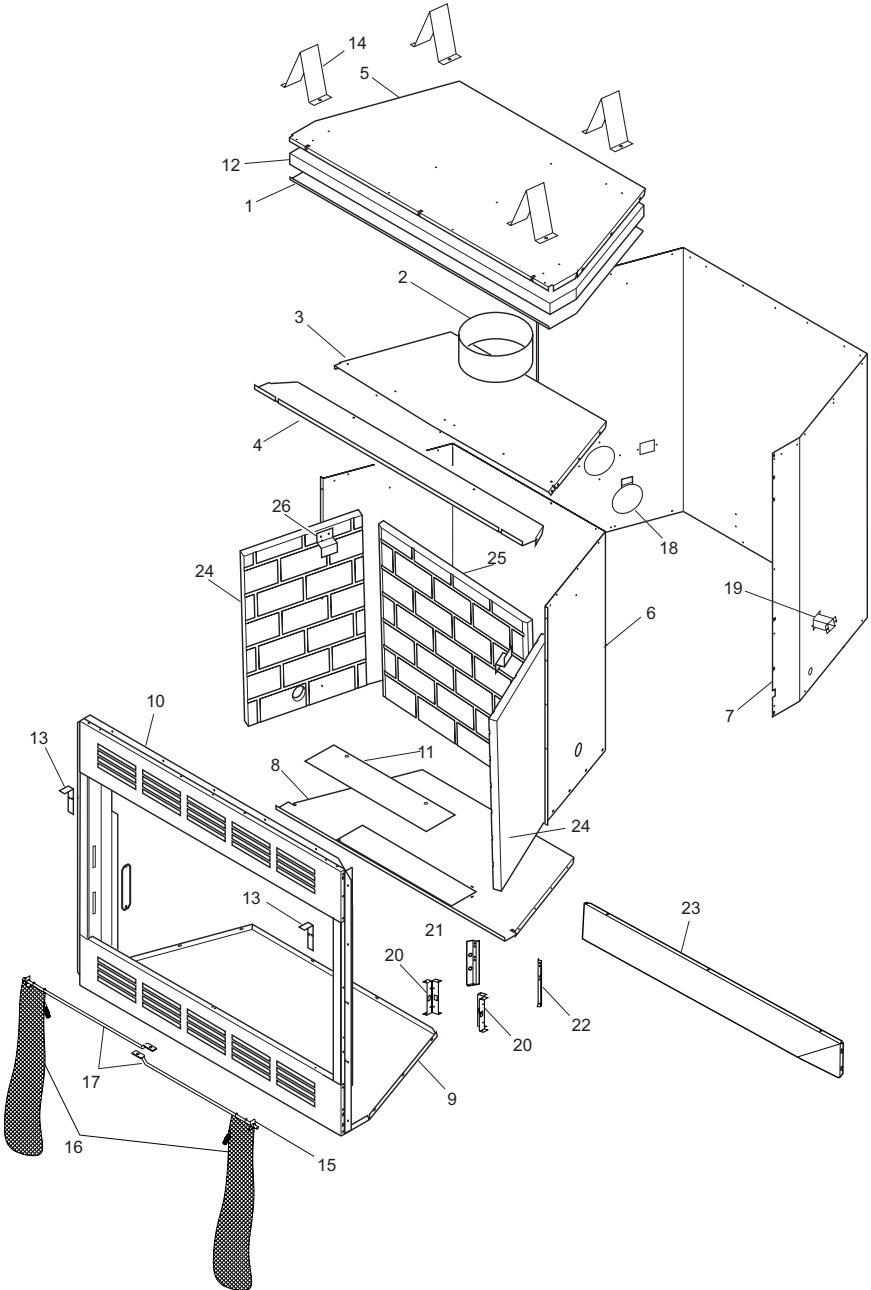

Figure 10 - Screw and Hood Placement (Model May Vary From Illustration)

PARTS

NON-CIRCULATING MODELS BV36(B), VBV36, BV42(B) AND VBV42
CIRCULATING MODELS BV36L(B), VBV36L, BV42L(B) AND VBV42L



PARTS

This list contains replaceable parts used in your firebox. When ordering parts, follow the instructions listed under [Replacement Parts](#) on page 14 of this manual.

KEY			(V)BV36	BV36B	(V)BV36L	BV36LB	(V)BV42	BV42B	(V)BV42L	BV42LB	QTY.
NO.	PART NO.	DESCRIPTION									
	**	Insulation Pan	•	•	•	•	•	•	•	•	1
2	**	Air Spacer	•	•	•	•	•	•	•	•	1
3	**	Firebox Top	•	•	•	•	•	•	•	•	1
4	111431-01	Air Deflector	•	•	•	•					1
	108302-01	Air Deflector					•	•	•	•	1
5	**	Fireplace Top	•	•	•	•	•	•	•	•	1
6	**	Firebox Wrapper	•	•	•	•	•	•	•	•	1
7	**	Outer Wrapper/Insulation Assembly	•	•	•	•	•	•	•	•	1
8	**	Firebox Floor	•	•	•	•	•	•	•	•	1
9	**	Wrapper Bottom	•	•	•	•	•	•	•	•	1
10	**	Front Face Weldment, Smooth	•	•			•	•			1
	**	Front Face Weldment, Louvered			•	•			•	•	1
11	21198	Blower Access Plate	•	•	•	•	•	•	•	•	1
12	**	Top Insulation	•	•	•	•	•	•	•	•	1
13	123495-01	Bracket	•	•	•	•	•	•	•	•	2
14	20280	Top Standoff	•	•	•	•					4
	106959-01	Top Standoff					•	•	•	•	4
15	11418	Push-On Nut	•	•	•	•	•	•	•	•	2
16	107127-01	Screen	•	•	•	•					2
	108424-01	Screen					•	•	•	•	2
17	20806	Screen Rod	•	•	•	•					2
	108780-01	Screen Rod					•	•	•	•	2
18	**	Side Damper Weldment	•	•	•	•	•	•	•	•	1
19	107128-01	Gas Conduit	•	•	•	•	•	•	•	•	4
20	**	Firebox Legs Rear	•	•	•	•	•	•	•	•	2
21	**	Firebox Leg, Left	•	•	•	•	•	•	•	•	1
22	**	Firebox Leg, Right	•	•	•	•	•	•	•	•	1
23	123494-01	Hood	•	•	•	•					1
	123494-02	Hood					•	•	•	•	1
24	124483-01	Side Refractory		•		•	•	•	•	•	2
25	124484-01	Rear Refractory		•	•						1
	124485-01	Rear Refractory					•		•		1
26	20027	Refractory Bracket		•		•	•	•	•	•	2

** Not a field replaceable part

REPLACEMENT PARTS

Note: Use only original replacement parts. This will protect your warranty coverage for parts replaced under warranty.

PARTS UNDER WARRANTY

Contact authorized dealers of this product. If they can't supply original replacement part(s), call FMI PRODUCTS, LLC at 1-866-328-4537.

When calling, have ready:

- your name
- your address
- model and serial numbers of your heater
- how heater was malfunctioning
- purchase date

Usually, we will ask you to return the part to the factory.

PARTS NOT UNDER WARRANTY

Contact authorized dealers of this product. If they can't supply original replacement part(s), call FMI PRODUCTS, LLC at 1-866-328-4537 for referral information. A list of authorized dealers can be found by visiting **www.fmiproducts.com**.

When calling FMI PRODUCTS, LLC, have ready:

- model and serial numbers of your heater
- the replacement part number

TECHNICAL SERVICE

You may have further questions about installation, operation, or troubleshooting. If so, contact FMI PRODUCTS, LLC at 1-866-328-4537.

When calling please have your model and serial numbers of your heater ready.

You can also visit FMI PRODUCTS, LLC's web site at **www.fmiproducts.com**.

ACCESSORIES

NOTICE: All accessories may not be available for all fireplace models.

Purchase these accessories from your local dealer. If they can not supply these accessories call FMI PRODUCTS, LLC at 1-866-328-4537 for information. You can also write to the address listed on the back page of this manual.

FIRE CRACKLE - CF6-A

Creates the sound of a real burning fire.

OUTSIDE AIR KIT

AK4 - Complete Kit w/ Collar, Hood & 3' of Flex Tube

Optional kit provide additional air to reduce build-up of condensation that occurs in today's tightly constructed homes.

RUNNING BOND CERAMIC FIBER BRICK LINER KITS

BLB36SF - 36" Liner Kit

BLB42SF - 42" Liner Kit

RUNNING BOND REFRACTORY BRICK LINER KITS

BLB36SR - 36" Liner Kit

BLB42SR - 42" Liner Kit

WARRANTY

KEEP THIS WARRANTY

Model (located on product or identification tag) _____

Serial No. (located on product or identification tag) _____

Date Purchased _____

Keep receipt for warranty verification.

FMI PRODUCTS, LLC LIMITED WARRANTIES

New Products

Standard Warranty: FMI PRODUCTS, LLC warrants this new product and any parts thereof to be free from defects in material and workmanship for a period of four (4) years from the date of first purchase from an authorized dealer provided the product has been installed, maintained and operated in accordance with FMI PRODUCTS, LLC's warnings and instructions.

For products purchased for commercial, industrial or rental usage, this warranty is limited to 90 days from the date of first purchase.

Factory Reconditioned Products

Limited Warranty: FMI PRODUCTS, LLC warrants factory reconditioned products and any parts thereof to be free from defects in material and workmanship for 30 days from the date of first purchase from an authorized dealer provided the product has been installed, maintained and operated in accordance with FMI PRODUCTS, LLC's warnings and instructions.

Terms Common to All Warranties

The following terms apply to all of the above warranties:

Always specify model number and serial number when contacting the manufacturer. To make a claim under this warranty the bill of sale or other proof of purchase must be presented.

This warranty is extended only to the original retail purchaser when purchased from an authorized dealer, and only when installed by a qualified installer in accordance with all local codes and instructions furnished with this product.

This warranty covers the cost of part(s) required to restore this product to proper operating condition and an allowance for labor when provided by a FMI PRODUCTS, LLC Authorized Service Center or a provider approved by FMI PRODUCTS, LLC. Warranty parts must be obtained through authorized dealers of this product and/or FMI PRODUCTS, LLC who will provide original factory replacement parts. Failure to use original factory replacement parts voids this warranty.

Travel, handling, transportation, diagnostic, material, labor and incidental costs associated with warranty repairs, unless expressly covered by this warranty, are not reimbursable under this warranty and are the responsibility of the owner.

Excluded from this warranty are products or parts that fail or become damaged due to misuse, accidents, improper installation, lack of proper maintenance, tampering, or alteration(s).

This is FMI PRODUCTS, LLC's exclusive warranty, and to the full extent allowed by law; this express warranty excludes any and all other warranties, express or implied, written or verbal and limits the duration of any and all implied warranties, including warranties of merchantability and fitness for a particular purpose to four (4) years on new products and 30 days on factory reconditioned products from the date of first purchase. FMI PRODUCTS, LLC makes no other warranties regarding this product.

FMI PRODUCTS, LLC's liability is limited to the purchase price of the product, and FMI PRODUCTS, LLC shall not be liable for any other damages whatsoever under any circumstances including indirect, incidental, or consequential damages.

Some states do not allow limitations on how long an implied warranty lasts or the exclusion or limitation of incidental or consequential damages, so the above limitation or exclusion may not apply to you.

This warranty gives you specific legal rights, and you may also have other rights which vary from state to state.

For information about this warranty contact:

FMI PRODUCTS, LLC
2701 S. Harbor Blvd.
Santa Ana, CA 92704
1-866-328-4537
www.fmiproducts.com

123492-01
Rev. E
12/09