

Flashlink®



USER MANUAL

FR-CWDM

flashlink® Coarse Wavelength Division Multiplexing System

Network Electronics ASA
Thorøya
3230 Sandefjord, Norway
Phone: +47 33 48 99 99
Fax: +47 33 48 99 98
e-mail: support@network-electronics.com
www.network-electronics.com
Direct Service Phone: +47 90 60 99 99

Network Electronics ASA, Thorøya, 3204 Sandefjord, Norway, Tel.:+47 33 48 99 99 Fax: +47 33 48 99 98
E-mail: support@network-electronics.com - Web: <http://www.network-electronics.com>

Technical specifications are subject to be changed without notice

network
THE INNOVATOR

Index

0. Revision history	4
1. General information	5
1.1 Handling of optical fibers.....	5
1.2 Laser safety precautions.....	5
1.3 Connector cleaning.....	7
1.6 Power dissipation in the flashlink® CWDM-system.....	8
1.7 Warranty Statement.....	8
2. Interconnection of the CWDM-system	9
2.1 4-channel systems.....	10
2.2 8-channel systems.....	11
3. CWDM system description	12
3.1 Specifications.....	13
3.2 Connection drawing.....	15
3.3 Module card LED's.....	15
4. Power connection and RS-422 connection	16
4.1 Pin-out DB9:.....	16
4.2 RS-422 connection.....	17
4.3 Pin-out RS-422.....	17
4.4 RS-422 protocol.....	18
4.5 Connecting several sub-racks together.....	18
4.6 Address setting on each sub-rack.....	19
5. Module card mounting	21
5.1 Removing the front panel.....	21
5.2 Card insertion.....	23
5.3 Card removal.....	25
5.4 Attaching the front panel.....	26
6. Fiber optics	28
6.1 Handling of optical fibers.....	28
6.2 Fiber optic Connector.....	29
6.3 Transmission budget.....	31
7. Application notes	32
7.1 ADM-nodes.....	32
8. Troubleshooting	33
Declaration of conformity with CE	35
General environmental requirements for Network flashlink® equipment	35

Accessories enclosed

- Plastic dust caps for fiber optical connectors
- Fiber optic patch cords for interconnection of sub-rack frames
- 110Ω termination plugs for the Gyda® system controller (optional)
- Cat-5 cables for RS-422 connection to Gyda® (optional)

0. Revision history

The latest version is always available in pdf-format on our web-site:

<http://www.network-electronics.com/>

Current revision of this document is the uppermost in the table below.

Revision	Replaces	Date	<u>Change Description</u>
1	0	14.05.03 RS	Corrected interconnection of sub-racks with RS-422
0	A	19.11.02 RS	Product release
A		01.10.02 RS	Preliminary revision

1. General information

1.1 Handling of optical fibers

This product includes fiber optic equipment. Access to the optical signal path is given through the optical connectors (see separate chapter).

Even though a fiber optic cable can look almost the same as an electrical wire, special care must be taken. Inside the cable is a fiber made of glass. Glass has very different physical properties than the copper used in electrical wires.

In practical terms this means that these precautions must be taken:

- Do not bend the fiber too much
- Do not put anything on top of the optical fiber.
- Keep the connectors clean from dust

If a fiber is bent too much, parts of the transmitted light is lost or in worst case the glass is broken. All the datasheets of optical fibers have a point called "minimum bend radius". This means that any bending of the fiber corresponding to a bend radius less than the given value will make the light leak out of the fiber. A typical value is 20 mm to 40 mm (Bellcore standard) for single mode fibers.

You should also avoid putting any heavy items on top of the optical fibers, because this will change the optical properties of the fiber, and contribute to errors in the transmitted signal.

Unless the fiber is damaged, it will regain its optical properties after a bend is straightened out or the items are removed / the squeeze is released.

1.2 Laser safety precautions

Guidelines to limit hazards from laser exposure.

All the available EO units in the flashlink[®] range include a laser. Therefore this note on laser safety should be read thoroughly.

The lasers emit light at wavelengths around 1550 nm. This means that the human eye cannot see the beam, and the blink reflex cannot protect the eye. (The human eye can see light between 400 nm to 700 nm).

A laser beam can be harmful to the human eye (depending on laser power and exposure time), therefore:

!! BE CAREFUL WHEN CONNECTING / DISCONNECTING FIBER PIGTAILS (ENDS).

NEVER LOOK DIRECTLY INTO THE END OF THE FIBER.

NEVER USE MICROSCOPES, MAGNIFYING GLASSES OR EYE LOUPES TO LOOK INTO A FIBER END.

USE LASER SAFETY EYEWEAR BLOCKING LIGHT AT 1310 nm AND AT 1550 nm.

Instruments exist to verify light output power: Power meters, IR-cards etc.

The FR-2RU-10-2 is classified as Class 1 laser product according to EN 60 825-1:94/A11:96, and CFR Ch1(1997) Part 1040.10.

If the front panel is removed, the FR-2RU-10-2 is classified as Class 1 laser product according to EN 60 825-1:94/A11:96, and class IIb according to CFR Ch1(1997) Part 1040.10.

Maximum output power: 5 mW.

Operating wavelengths: >1465nm.

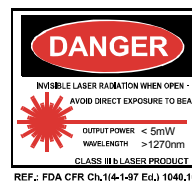

1.3 Connector cleaning

Optical connectors should be kept clean at all times. Whenever a connector is disconnected the enclosed protective dust cap should be put on. This protects the ferrule used for fiber alignment and prevents the surface from being scratched or damaged.

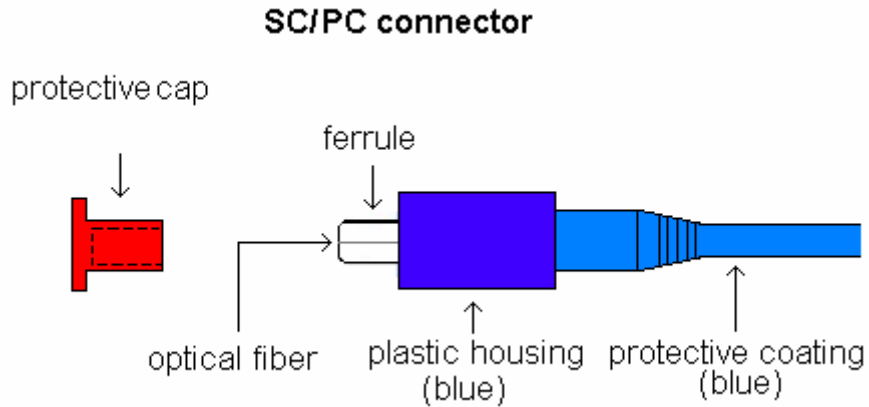

Figure 1.1: The different parts of an SC/PC connector

Cleaning procedure:

If the ferrule is dirty it must be cleaned before re-connection.

If a clean connector is pressed against a dirty connector, both connectors will become dirty resulting in possible degradation of signal quality. Or even worse, you may damage the surface of the connector(s). We recommend that the cleaning procedure is done by using a special cleaning-tape suitable for this purpose, called CleTop (see picture below).



1.6 Power dissipation in the flashlink® CWDM-system.

The low power consumption of the different modules that can be used in the CWDM system, implies that there is no need for forced ventilation of the system in order for the system to work properly.

The operational temperature for the CWDM-system is 0°-40°C.

1.7 Warranty Statement

The following warranty terms and conditions shall apply to all products manufactured by Network Electronics.

Guarantee

Network Electronics guarantees the good quality of the goods supplied for the period started, or when no period is started for a period of three (3) years as from the date from which they have been put in use, but in no event for more than forty (40) months as from the date of despatch, against all defects or failures which appear therein under proper use, and arise solely from faulty materials or workmanship, is being understood that:

Such guarantee does not cover damage sustained by normal wear or tear or any damage arising in consequence of negligence or improper use and storage.

Such guarantee shall not include any items to which a specific manufacturer's guarantee applies.

Network Electronics liability under this guarantee shall be to supply to the purchaser free of charge, replacements of parts that have proved to be defect. These will be repaired to our costs, provided that we are informed by purchaser in writing, telefax or mail within fourteen days after the defects has been revealed, and the defective goods have been placed at Network Electronics disposal. The defective parts shall become Network Electronics property as soon as they have been replaced.

Product Liability

Network Electronics shall not be liable to damages to persons or property unless the purchaser proves that the loss is due to negligence on the part of Network Electronics or Network Electronics personnel.

Network Electronics shall not be liable for indirect losses of any kind such as loss of trade, loss of profit etc.

In the event that Network Electronics is held liable by a third party for damages arising from product liability the purchaser shall be obliged to become a part to any litigation initiated by a third part against Network Electronics.

2. Interconnection of the CWDM-system

The interconnection of each sub-rack is shown below, and this will apply to all sub-racks. The ports are as follows:

C= Common port

1-4 = Channel wavelengths for sub-rack channels 1-4

U= Upgrade port

The GYDA system controller-card, is an optional card, and not part of the standard product.

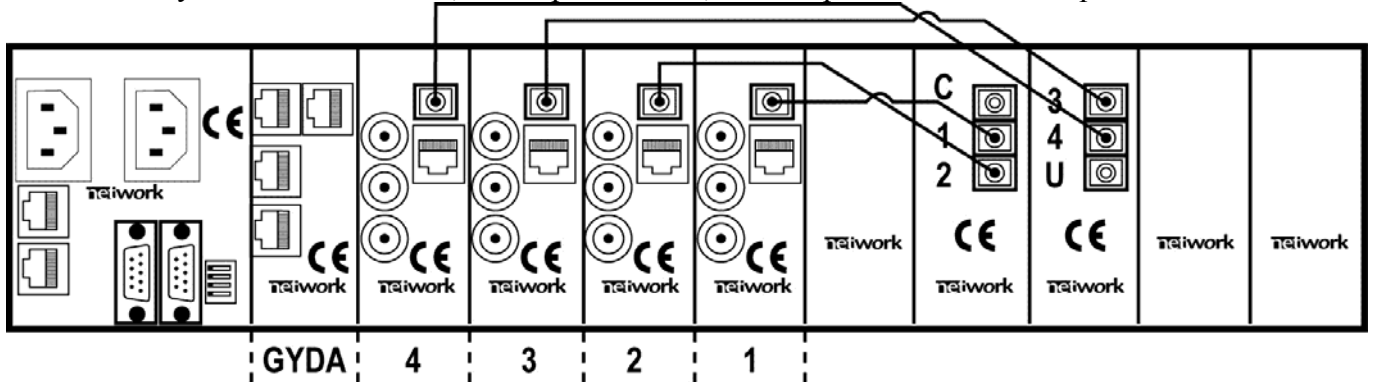

Figure 2.1: Optical interconnection of a sub-rack in the CWDM system

In the different systems described in this chapter, we only show how to connect the different sub-racks together. The patching of each frame is omitted in these drawings, since the patching is the same as in figure 2.1 for all sub-racks regardless of whether it is an Rx or Tx sub-rack frame.

Apply signals to the different channels and connect the power cords.

For installation of Gyda® see Chapter 9.

2.1 4-channel systems

A 4-channel system consists of two sub-racks of 2RU each. One sub-rack at the transmitter side and one sub-rack on the receiver side. A feature of the system is that by swapping a laser card with the corresponding receiver card, a bi-directional system is possible.

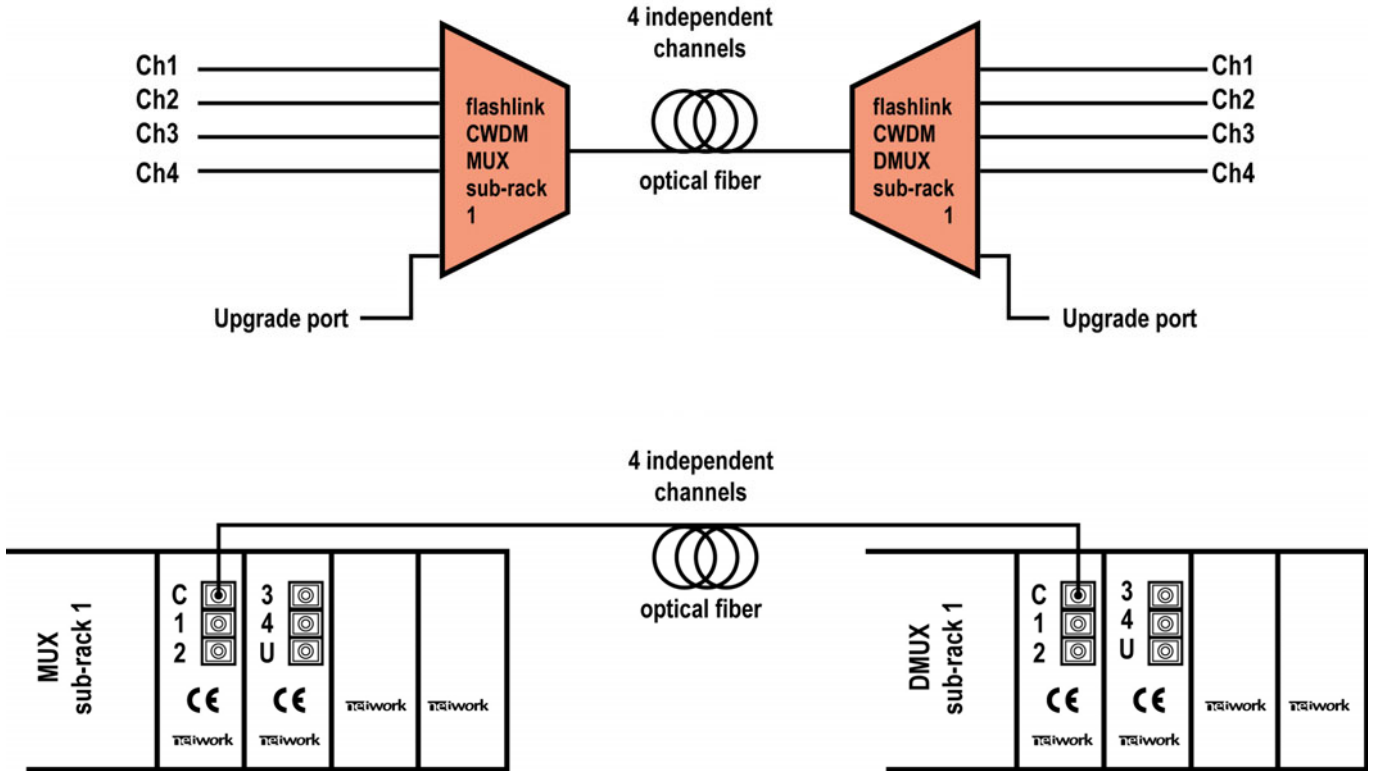

Figure 2.2: 4-channel CWDM system, description of system and connections of the sub-racks.

2.2 8-channel systems

Expanding the 4-channel system with another sub-rack frame makes an 8-channel CWDM system able to transmit 8 channels in any direction. Examples of how this system can be configured, is shown in figures 2.3.

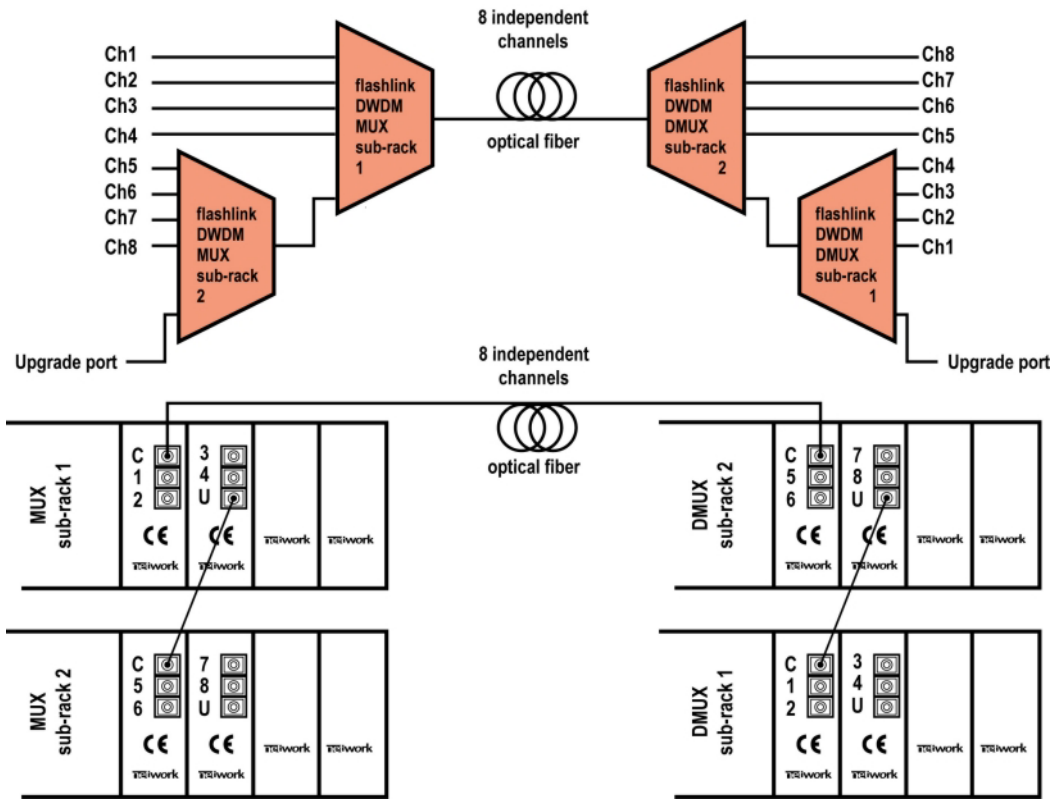

Figure 2.3: 8-channel CWDM system, description of system and connections of the sub-racks 1 and 2. Notice the reverse order of the frames at the two ends of the fiber.

3. CWDM system description

The CWDM concept requires defined sub-rack frames (FR-CWDM) with specified MUX-modules and lasers on the transmitter side, and DEMUX-modules and PIN-diodes on the receiver side. Each frame is based on the original flashlink frame, FR-2RU-10-2, and contains modules needed for simultaneous transport of 4 format- and protocol-independent signals. FR-CWDM has the same options for power redundancy and system control as the FR-2RU-10-2. Note that a point-to-point link always requires the same type of MUX and DEMUX.

The product is available in 4 different versions:

Transmitter side, up to 540Mbps

FR-CWDM-MX4-4	Sub-rack multiplexer frame 1, channel 1-4
FR-CWDM-MX4-8	Sub-rack multiplexer frame 2, channel 5-8

Receiver side, up to 540 Mbps

FR-CWDM-DMX4-4	Sub-rack demultiplexer frame 1, channel 1-4
FR-CWDM-DMX4-8	Sub-rack demultiplexer frame 2, channel 5-8

3.1 Specifications

AC power:	AC power supply module 100-260 VAC (PWR-AC15/15/5V)
DC power (optional):	DC power supply module 36-72 VDC (PWR-DC15/15/5V)
Redundant power (optional)	
Dimensions:	483 x 88 x 178 mm (19", 2RU)
Card slots	10 (9 reserved)
Power supply slots (reserved)	2
Internal voltages :	+5V, + 15 V, -15 V

Optical Output

Transmission circuit fiber:	Single Mode
Light source:	DFB Laser
Centre Wavelengths:	Acc. to ITU-T G.694.2, 1470, 1490, 1510, 1530, 1550, 1570, 1590 and 1610nm.
Wavelength accuracy:	± 6nm
Optical power:	0 dBm typ.
Return loss	Better than 30 dB typ.
Maximum reflected power:	4%
Connector	SC/UPC

Optical Input (SDI-OE-L, see respective user manual for other formats)

Data rate optical:	143Mbps – 540Mbps
Sensitivity SDI-OE-L:	better than –30dBm typ.
Maximum input power SDI-OE-L:	-17 dBm
Detector overload threshold:	Min. –6dBm, typ. –3dBm
Optical wavelengths:	1200-1600 nm
Transmission Circuit Fiber	Multi Mode 50/125µm, Single Mode compatible
Return loss:	better than 40 dB w/Single Mode fiber (typ.)
Connector	SC/UPC

Insertion loss optical filters

4-channel system	Max. 6dB per mux/demux pair
8-channel system	Max. 8dB per mux/demux pair

Channel overview

The channel wavelengths are specified in a recommendation from the International Telecommunications Union (ITU), called ITU-T G.694.2. The channel spacing in the system is 20nm.

Sub-rack 1:

Channel #	Wavelength
1	1510nm
2	1530nm
3	1550nm
4	1570nm

Sub-rack 2:

Channel #	Wavelength
5	1470nm
6	1490nm
7	1590nm
8	1610nm

Supported bit rates

Broadcast:

- 143 Mbps Digital NTSC
- 177 Mbps Digital PAL
- 270 Mbps SDI
- 360 Mbps SDI
- 540 Mbps SDI
- DVB-ASI
- SDTI
- Embedded AES and Data
- SMPTE 310
- M2S (Divicom)

Telecom:

- 140 Mbps E4
- 155 Mbps STM-1 (OC-3c)

Other:

- 100 Mbps Fast Ethernet
- RS-422
- AES (single or multi channel)

3.2 Connection drawing

Figure 1 shows the connections of an FR-CWDM sub-rack frame, as seen from the rear. From left to right we see the connector module for the power supply, the connector module for the optional GYDA[®] Rack System Controller, the connector modules for the 4 channels, and the connector modules for the optical filtering of the different channels.

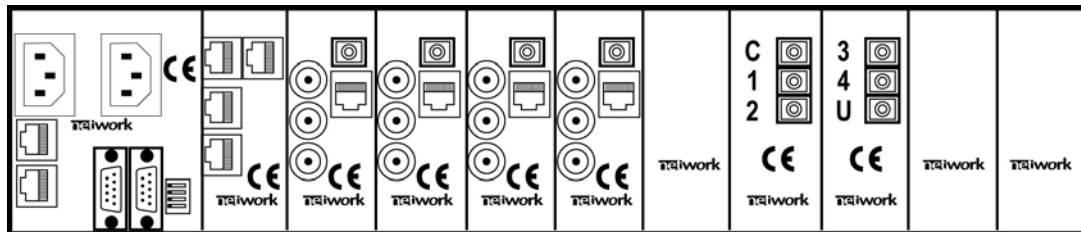

Figure 3.1: Example of fully equipped FR-CWDM with the Gyda[®] Rack System Controller.

3.3 Module card LED's

See the respective user manuals for the different modules that fit in the frame.

4. Power connection and RS-422 connection

Figure 4.1 shows the power connections of the sub-rack as well as the RS-422 connections and the DIP-switches for address setting of the sub-rack.

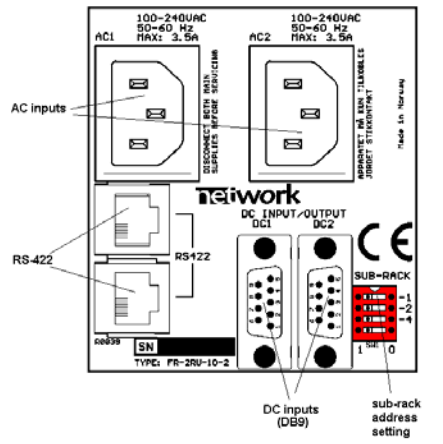

Figure 4.1: Connector module for the power module.

AC: Connect mains to the sub-rack with a mains cord with an IEC 320 connector.

DC: Connect the DB9 male connector from the external DC power supply to the main unit. Tighten the screws to ensure a proper contact. The DC inputs have the same function, the left input (DC1) is for the left power module when seen from the rear and DC2 is for the right power module when seen from the rear.

4.1 Pin-out DB9:

The maximum current drawn from each pin of the DB9 connector is 2,5A.

The power supply is able to deliver an overall maximum current of 5,5A at 5V and 1A at 15V.

The pin-out is the same for both DC1 and DC2.

Pin 1	GND for DC	
Pin 2	+5V	Output
Pin 3	Relay	Open in normal state
Pin 4	+15V	Output
Pin 5	positive part of 48V DC supply	Input
Pin 6	Reserved	
Pin 7	Relay	Open in normal state
Pin 8	-15V	Output
Pin 9	negative part of 48V DC supply	Input

Pin 1, 2, 3 and 8 are common to both DC1 and DC2. (Physically connected).

When the power supply is in operation, a green LED will light on the front.



Figure 4.2: The front of the flashlink® frame, showing the power LED's.

If a redundant power supply solution is used, both power-LED's will show green light. In the FR-CWDM positions 1-5 contains only optical components with no electrical connections, hence there are no status-LED's in the first five card positions.

4.2. RS-422 connection

At the rear end of the sub-rack is an RS-422 bus. When used in combination with the GYDA®-SC-M Rack System Controller, up to 8 sub-racks can be controlled and monitored. On the rear end of the sub-rack are DIP-switches where each sub-rack can be assigned its own address (see figure 4.1). The RS-422 interfaces are also shown in figure 4.1.

4.3 Pin-out RS-422

Pin 1	Rx A(+)
Pin 2	Rx B(-)
Pin 3	Tx A(+)
Pin 4	Reserved
Pin 5	Reserved
Pin 6	Tx B(-)
Pin 7	nc
Pin 8	nc

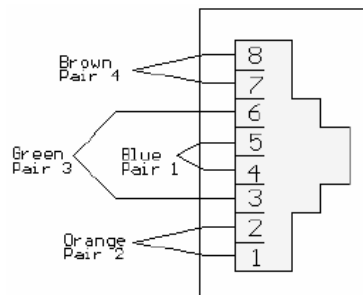

Fig. 4.3 RS-422 inlet

4.4 RS-422 protocol

Hardware interface

The hardware interface is basically RS-422. A serial communication standard much like RS-232 but with balanced lines. You can buy a simple RS-232 to RS-422 converter if you want to use a standard RS-232 port (e.g. a PC COM port).

The receive and transmit lines can be connected to make a true RS-485 bus, but this requires special care from the PC side, since you have to control the bus direction (e.g. using a dedicated RS-485 board with RS-485 drivers). We recommend using RS-422 for control. Data rate: 115200 bps, 8 bits, with one stop bit and no parity. All data is 8 bit ASCII (ISO8859-1 encoding), but currently any ASCII encoding will do). The protocol can be found on our web site <http://www.network-electronics.com/>

Addressing

Each card has a unique identifier called card position, which is assigned (through hardware pinning) automatically when a card is inserted into a sub-rack. The card positions are numbered from 1 to 10 from a user point of view. From a protocol (or software) point of view, the cards are addressed 0-9, but the user should always see positions 1-10 in menus, etc. Each sub-rack (if you use more than one) should have a unique sub-rack id, numbered 0-7 (user and protocol/software wise), more on this in section 4.6.

4.5 Connecting several sub-racks together

There are two versions of the GYDA[®]-SC Rack System Controller.

GYDA[®]-SC-S for control of a single rack

GYDA[®]-SC-M for control of multiple racks

This section only applies to systems including a GYDA[®]-SC-M Rack System Controller.

Several sub-racks can be connected to each other through the RS-422 ports on the rear.

One GYDA[®]-SC-M controller can control maximum 8 sub-racks.

You start with the sub-rack containing the GYDA[®]-SC-M Rack System Controller, and use 1 RS-422 port to loop through to the next.

The last sub-rack connected must be terminated with 110Ω in order to ensure proper operation. The other port of the rack containing the GYDA[®]-SC Rack System Controller must be left open, and cannot be connected to other sub-racks.

Figure 4.4 shows an example of how to connect 8 sub-racks together as seen from the rear end.

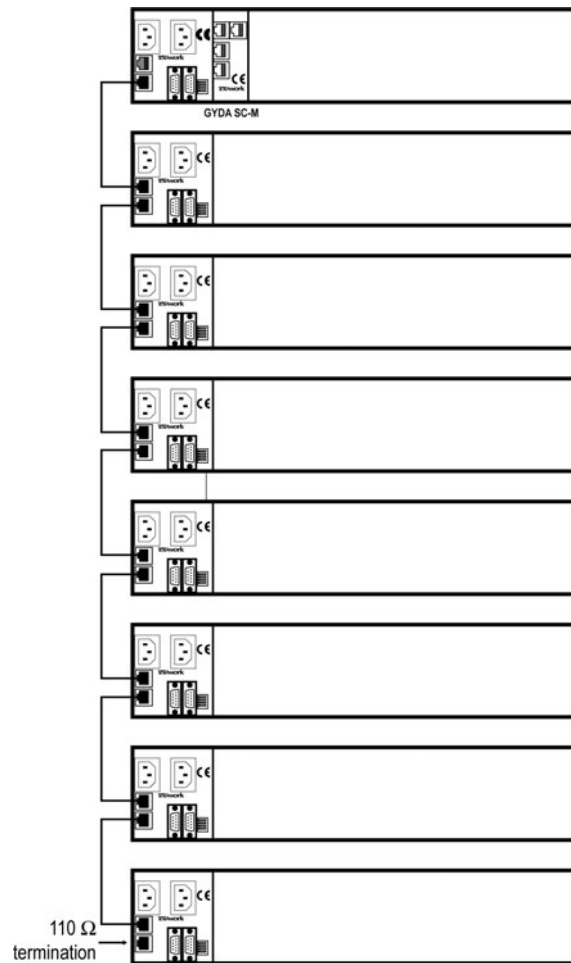

Figure 4.4: Control of 8 sub-racks with GYDA[®]-SC-M.

4.6 Address setting on each sub-rack

Each sub-rack can be assigned an address through the DIP-switches on the rear. Maximum 8 sub-rack addresses are available.

This address setting only applies when the sub-rack is used in combination with a GYDA[®]-SC-M Rack System Controller.

If you have more than 8 sub-racks together, you need several GYDA[®]-SC-M Rack System Controller cards.

!! In order to ensure proper operation of the system, it is important that no sub-racks controlled by the same GYDA[®]-SC-M Rack System Controller card have the same address set. Reset the sub-rack after reconfiguring the sub-rack system. The last sub-rack frame must be terminated with a 110Ω resistor.

The setting of the address of a sub-rack is as follows:

Address:

0 means switch to the right

1 means switch to the left

Address	4	2	1
0	0	0	0
1	0	0	1
2	0	1	0
3	0	1	1
4	1	0	0
5	1	0	1
6	1	1	0
7	1	1	1

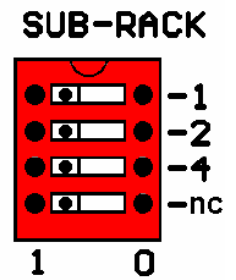

Fig. 4.5 DIP-switch

The GYDA-SC Rack System Controller automatically detects the position of the cards within each sub-rack.

More detailed information on the RS-422 configuration can be found in a separate document and at our web site: <http://www.network-electronics.com/>

5. Module card mounting

In order to replace modules within a sub-rack, the front panel must be removed. Each module has a corresponding connector module at the rear.

!! Be careful when swapping module cards. If a receiver card is removed from the sub-rack, an invisible laser beam may be emitted inside the sub-rack from the laser at the other end. The laser beam might be harmful to your eyes.

5.1 Removing the front panel

Detach the front panel by putting your fingers on the right hand side of the front panel and pull gently, as shown in the figures below. Then pull the front panel slightly to the right before removing it.

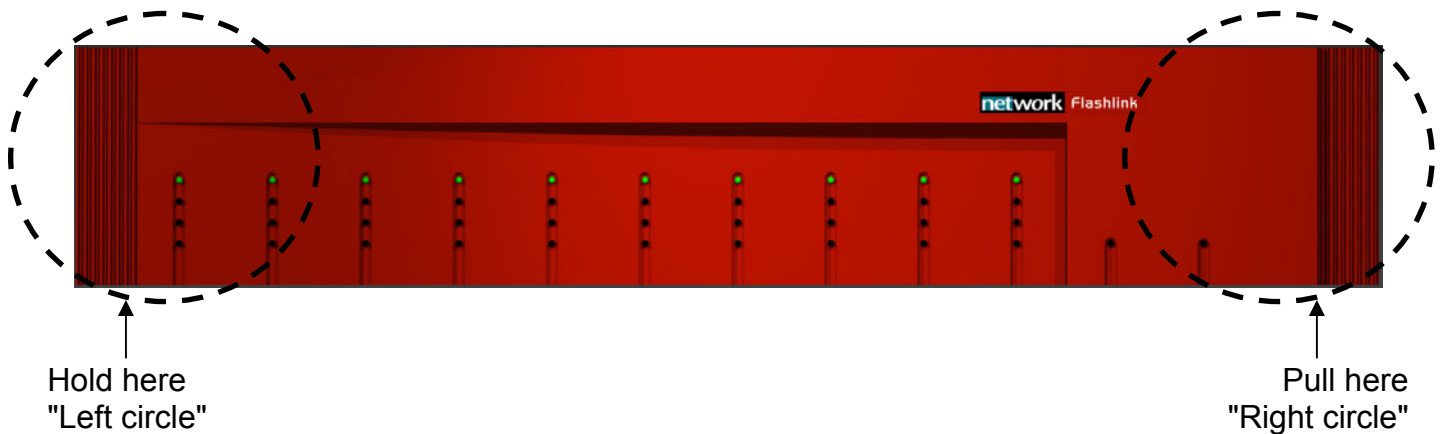

Figure 5.1: Removing the front panel

A more detailed description of how the front panel is detached is given in figure 5.2.

Step 1 looks at the details in the "right circle" seen from the right hand side, whereas the next two steps (step 2 and step 3) give the details of the "left circle" as seen from the top.

DETACHING THE FRONT PANEL

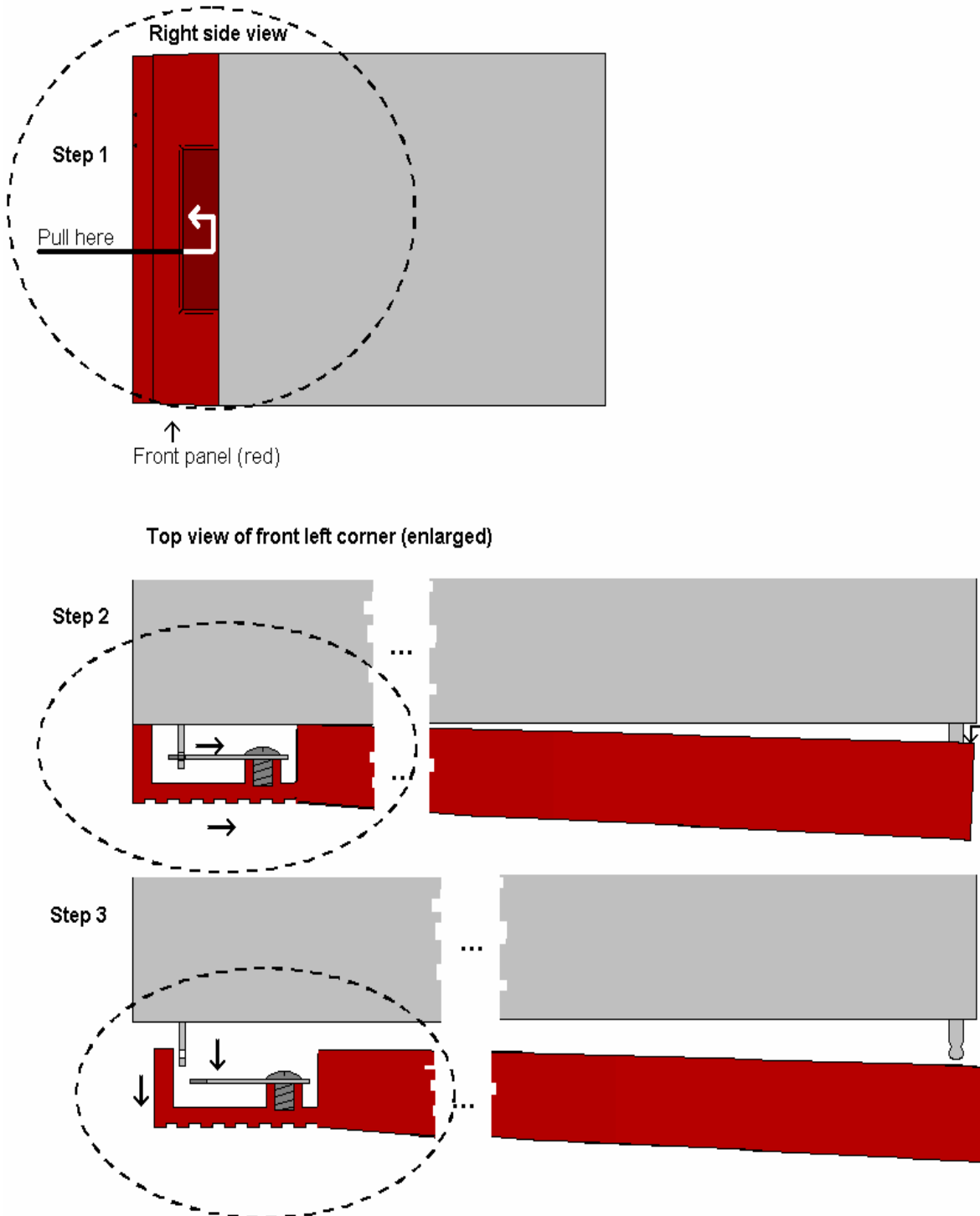

Figure 5.2: Removing the front panel (continued)

5.2 Card insertion

After the front panel is removed, full access to the card modules inside the sub-rack is given. Switch off the power with the power switch on the power-supply modules. The green light on the power module is now switched off. If the power supply is redundant, make sure that both power supplies are off.

The sub-racks are equipped with plastic guide rails to align the module cards into their respective positions 6 to 10. Just before the cards are inserted one should remove the plastic cap from the fiber ferrule as shown in figure 5.3. Do not touch the ferrule tip with your fingers.

Remove plastic cap before inserting module cards

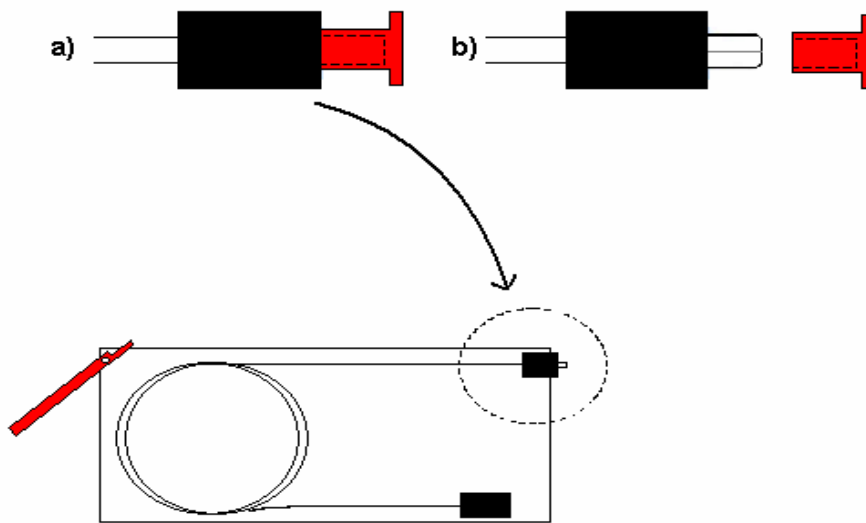

Figure 5.3: Removal of plastic cap (colour most often red or black)

SUB-RACK SEEN FROM THE FRONT WITH THE FRONT PANEL REMOVED

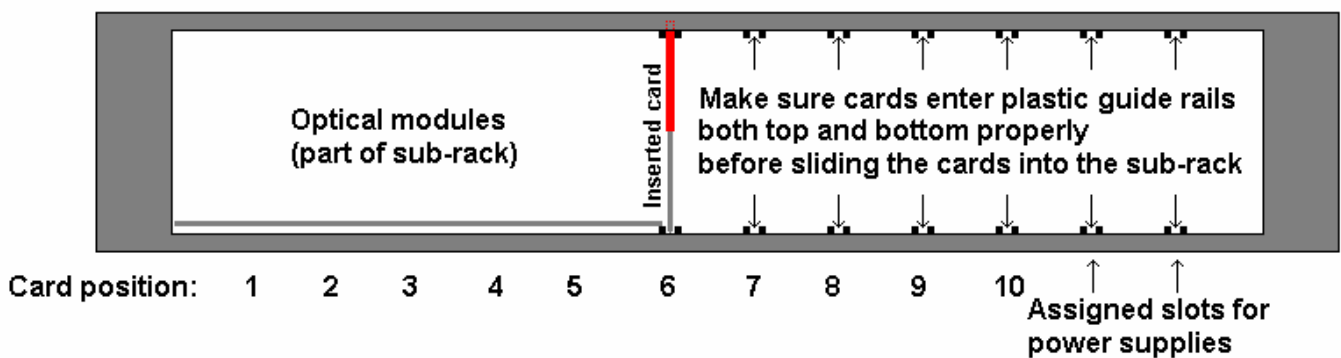

Figure 5.4: Overview of card positions inside an FR-DWDM sub-rack

!! Be careful when inserting the card into the sub-rack. The ferrule of the fiber may be damaged if it touches the sub-rack walls. Do not touch the ferrule tip with your fingers.

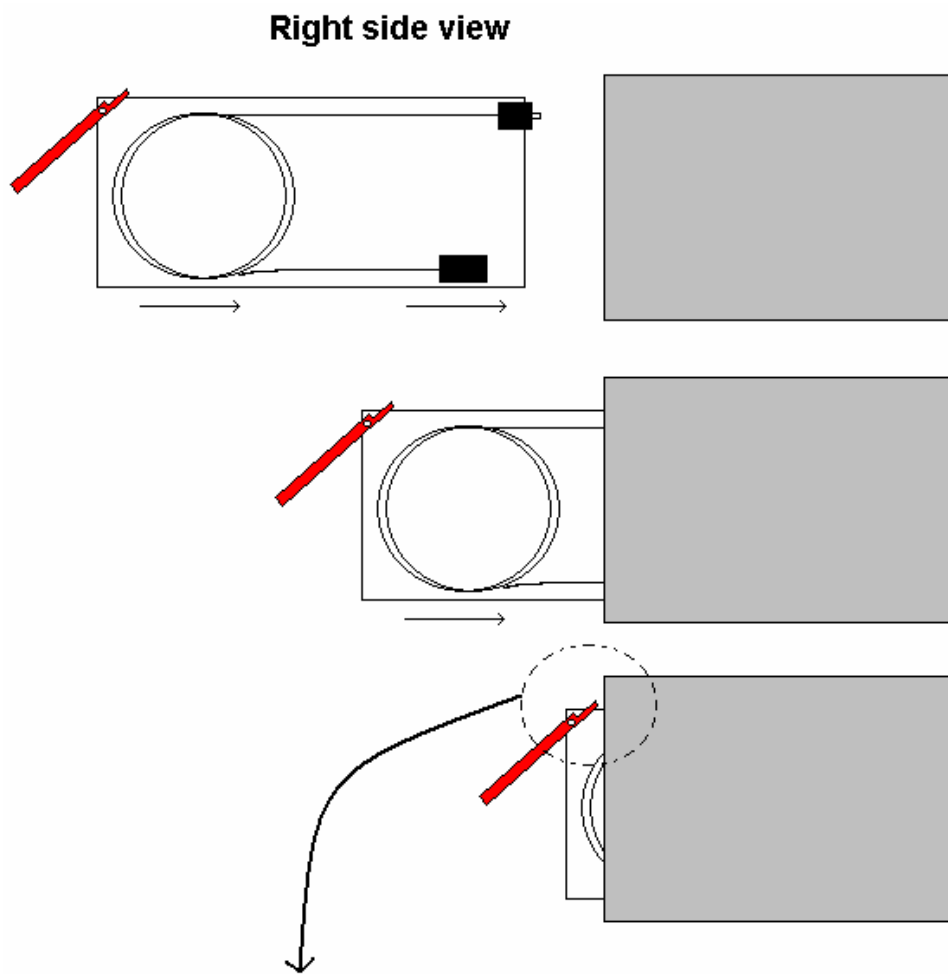

Figure 5.5: Inserting module cards

Slide the card into the plastic guide rails inside the sub-rack until the red handle is close to the sub-rack front. A detailed description of the last part of the insertion process is shown in figure 5.6.

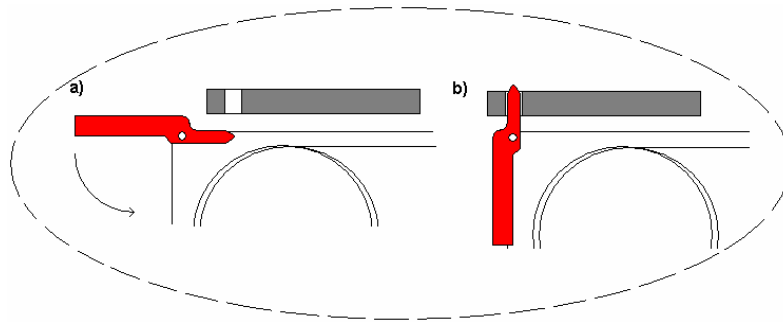

Figure 5.6: Inserting module cards (continued)

On the top of the rack is a hole above each module slot. When the tip of the handle is just below this hole, start bending the handle downwards as in figure 5.6 a). The tip of the handle enters the hole and the card is locked and proper contact ensured when the handle is in upright position (figure 5.6 b)).

5.3 Card removal

To remove a module card from the sub-rack frame, release the card by pulling the red handle until it is in horizontal position see figure 5.7 a). Then pull the card out of the sub-rack with the red handle (figure 5.7 b). After removing a card, it is important that the protective cap is put back on the ferrule tip (figure 5.7 c) and d).

!! When removing a receiver card from the sub-rack, the laser beam may be present inside the sub-rack (transmitted through the fiber). To avoid damaging your eyes, never look directly into the sub-rack unless you are 100 % sure that no laser beam is present inside the sub-rack.

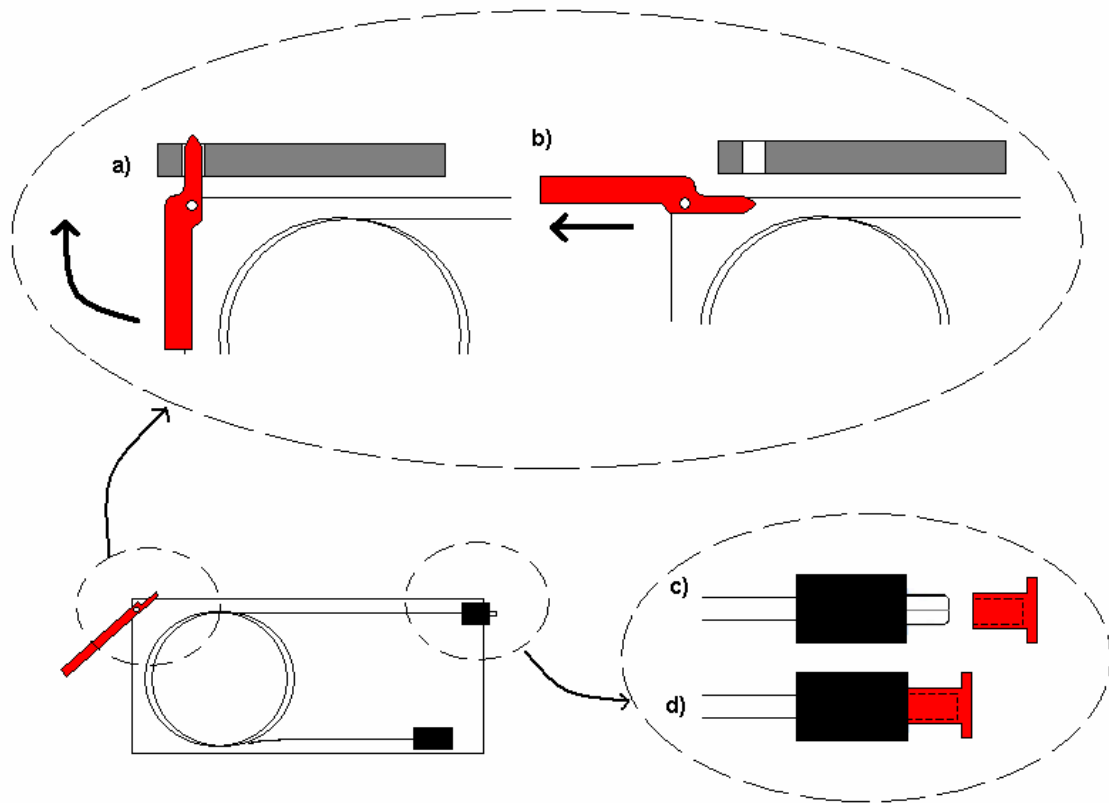

Figure 5.7: Removal of module card.

5.4 Attaching the front panel

To attach the front panel, we reverse the process described in section 5.1. Start by switching on the power supplies.

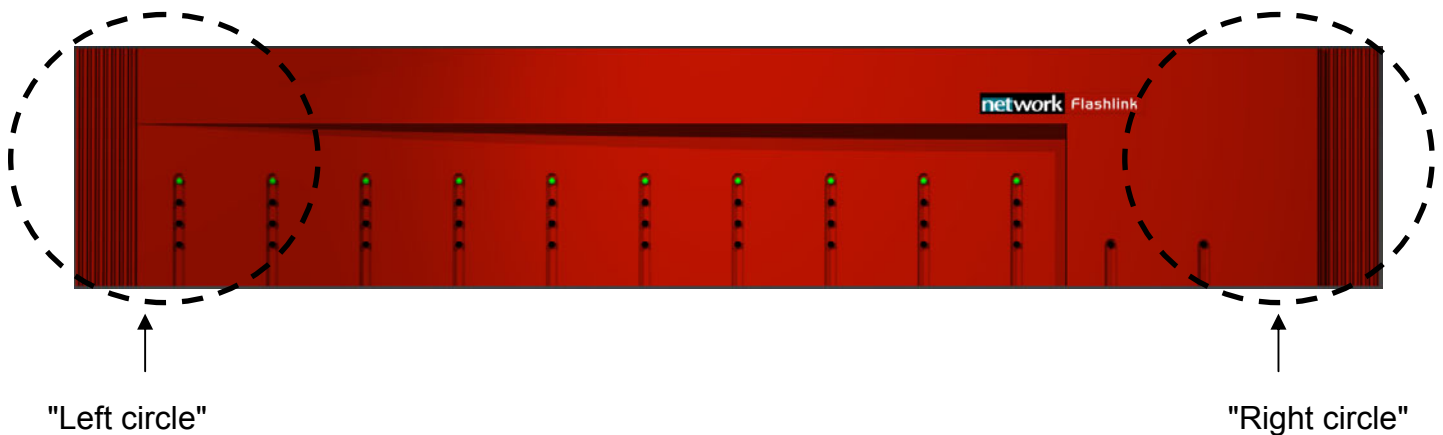

Figure 5.8: Attaching the front panel

We start in the "left circle" and slide the front into the slot as described in figure 5.9.

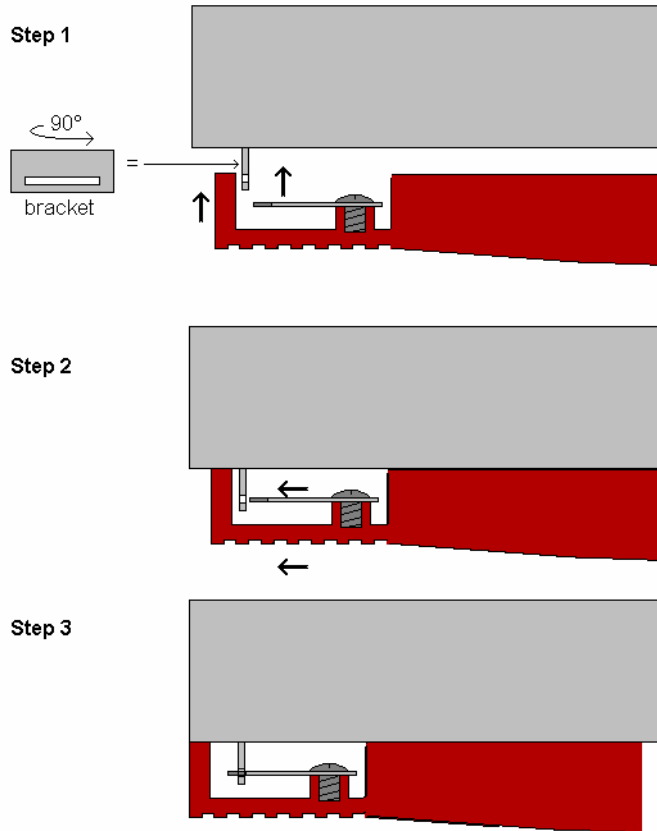

Figure 5.9: Attaching the front panel (Top view of front left corner).

After the front is attached to the left part of the sub-rack we attach in to the right part as shown in figure 5.10.

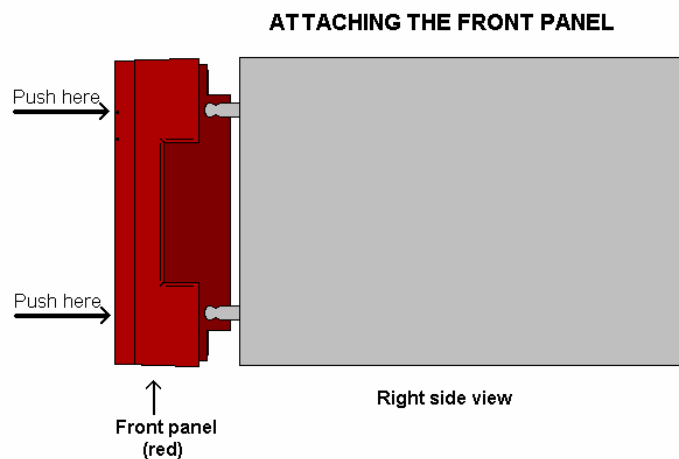

Figure 5.10: Attaching the front panel (continued)

A click sounds, and the front is attached.

6. Fiber optics

The FR-CWDM houses fiberoptic equipment.

Even though a fiberoptic cable can look almost the same as an electrical wire, special care must be taken. Inside the cable is a fiber made of glass. Glass has very different physical properties than the copper used in electrical wires.

6.1 Handling of optical fibers

In practical terms this means that these precautions must be taken:

- Do not bend the fiber too much
- Do not put anything on top of the optical fiber.
- Keep the connectors clean from dust

If a fiber is bent too much, parts of the transmitted light is lost.

We can compare light transmission through an optical fiber with driving a car at maximum speed. We want the road to be as straight as possible. The probability that your car is still on the road at the other end of the turn decreases with increasing curvature of the turn. Although there is a major difference: The transmitted light is gradually lost when the curvature increases, while your car is either on the road or not.

Therefore all the datasheets of optical fibers have a point called "minimum bend radius" or something similar. This means that any bending of the fiber corresponding to a bend radius less than the given value, will make the light leak out of the fiber.

A typical value is 20 mm to 40 mm (Bellcore standard) for single mode fibers.

You should also avoid putting any heavy items on top of the optical fibers, because this will change the optical properties of the fiber, and contribute to errors in the transmitted signal.

Unless the fiber is damaged, it will regain its optical properties after a bend is straightened out or the items are removed / the squeeze is released.

6.2 Fiber optic Connector

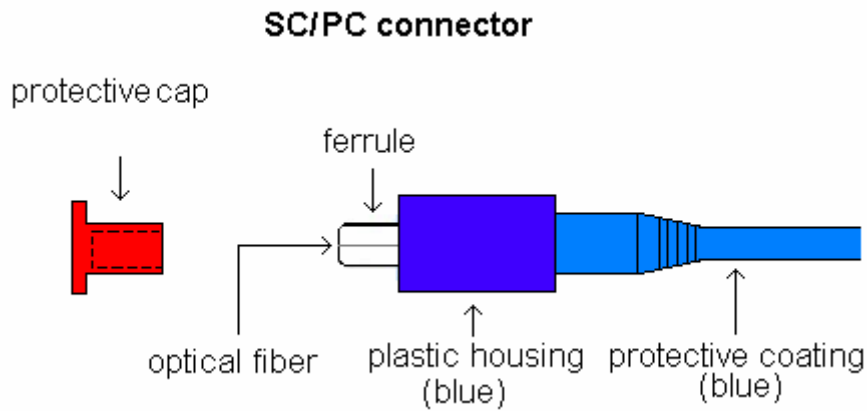

Figure 6.1: The different parts of an SC/PC Connector. Protective cap and coating may have different colour.

The flashlink product range utilises ultra polished SC/PC connectors (SC/UPC). These connectors have a return loss of better than 40 dB typ.

As compared to an electrical connection between two points, an optical connection is much more dependent on clean connectors. A dirty connector can add up to 10 dB of attenuation to your link. Either you have light entering the receiver or you have not. If there is no light at the receiver, then no signal will be detected. So the difference between an errorless connection over fiber, and no connection at all can be a dirty connector. See figs. 6.2 and 6.3.

Therefore: Clean connectors are of crucial importance.

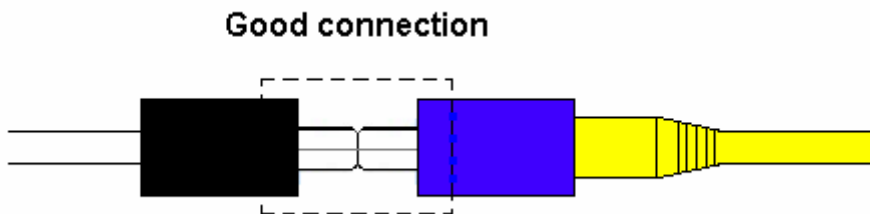

Figure 6.2: Good connector connection

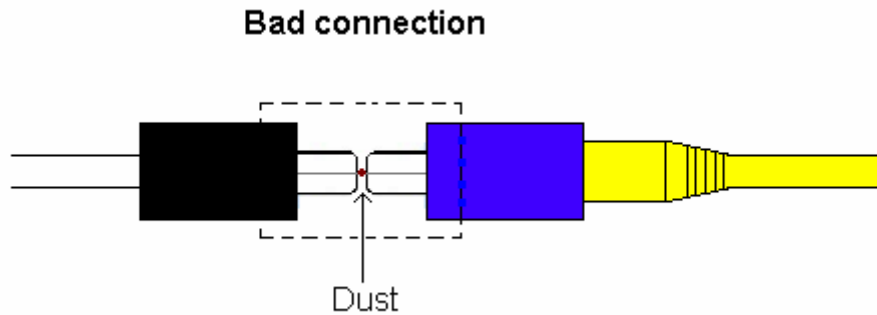

Figure 6.3: Bad connector connection

This also implies that people working with patching of fiber connectors must be aware of this. An optical fiber is made of glass and must be treated as such, not as an electrical wire. Compare it to the lens of a camera. You don't want fingerprints on the lens, but since the lens area is large compared to the cross-sectional area of a single mode fiber some light will pass the lens. The photo will be exposed but with degraded quality. A single mode optical fiber with a cross-sectional area of circa 1/10 000 000 000 square meter is far more dust-sensitive. To protect the connectors from dust, one shall always put on the plastic cap (red or other colour) which is on the connector end at delivery (or enclosed in a plastic bag) whenever a fiber end is disconnected.

If there is a chance that the fiber connector is dirty, one should clean the connector before putting it close to a clean fiber ferrule. If a clean connector is pressed against a dirty connector, both connectors will become dirty resulting in degradation of signal quality. Or even worse, you may damage the surface of the connector(s).

Using a special cleaning-tape suitable for this purpose does the cleaning. You may also use a soft tissue and iso-propyl alcohol, or dry and oil-free pressurised air.

To blow on the tip of the ferrule will not be sufficient.

More information on fiber optics can be found on our web site:

<http://www.network-electronics.com/>

6.3 Transmission budget

A transmission budget is an important part of planning an optical link.

An optical link is the place where the signals are transmitted as light through optical fiber and optical components.

The total transmission budget is the difference between the laser output power and the receiver sensitivity.

Example: A 0dBm laser and a -30dBm receiver gives a transmission budget of 30 dB.

Which means that the signal can be attenuated by 30 dB between the laser and the receiver while still being recoverable.

Patch panels, splices, optical filters and other optical components will add attenuation to the optical link. An estimate of the attenuation in the optical filters in the flashlink[®] CWDM-system is found in chapter 1.

It is not recommended to use the entire available budget, one should have 3 dB margin to compensate for future degradation of the optical link.

More on transmission budgets can be found on our web site:

<http://www.network-electronics.com/>

7. Application notes

7.1 ADM-nodes

Add-Drop-Multiplex nodes can be built by combining a digital video router with the flashlink[®] CWDM-system. An example of an 8-channel ADM-node is shown in figure 7.1.

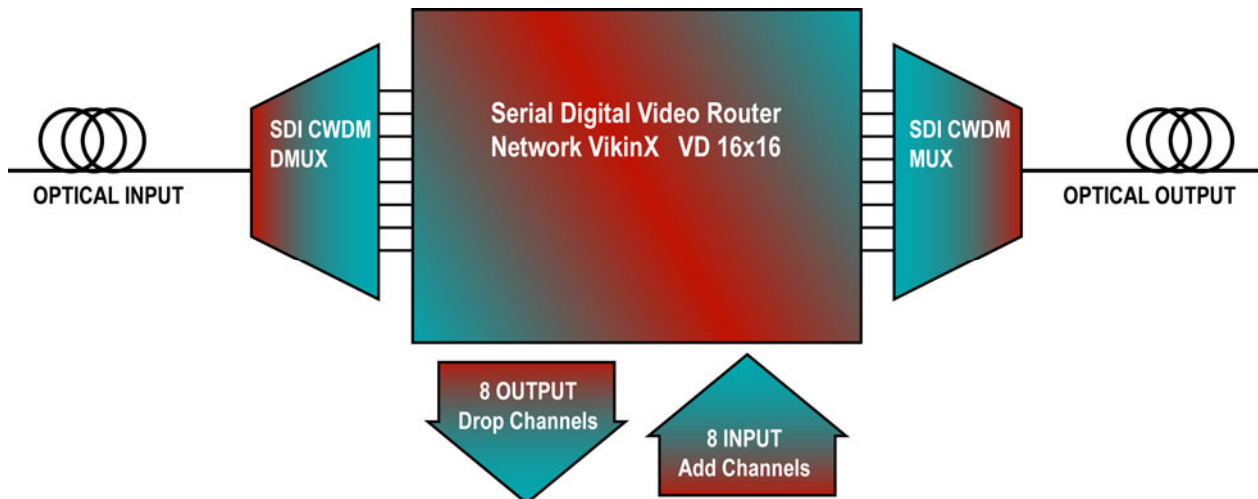

Figure 7.1: Example of an 8-channel ADM-node consisting of a 16x16 digital video router and an 8-channel CWDM-system.

At this node, channels can be dropped from the fiber and other channels can be added to the fiber. To have the maximum flexibility it is essential that the square digital video router has twice the size as the number of channels on the fiber, otherwise it will not be possible to change all the channels on the fiber simultaneously.

This add-drop process is done most cost-efficiently in steps of 4 channels, since each FR-CWDM contains 4 channels.

8. Troubleshooting

No green light on the power supply LED when electrical power is applied.

Each power supply has a separate on-off switch for the secondary side of the power supply. This is found on the power supply board behind the front panel.

Remove the front panel as described in chapter 5, and make sure that the power switch is down. If power is fed to the sub-rack the LED in front shall be green

Only one of the redundant power supplies has the green LED lit in front.

Remove the front panel and make sure that both power supplies have the power switch down and that electrical power is fed to both power supplies on the back planes. If this does not help, try to swap the positions of the power supplies. If the same power supply still is not lit, it must be replaced. If the power supply in the same position as before the swap still does not have a lit LED, the power supplied to the back plane is faulty.

One channel (wavelength) has significantly less power at the receiver end.

Clean the optical connectors of that particular channel as described in chapter 6. Both the connectors on the receiver side as well as on the transmitter side must be cleaned. Make sure that all connectors are correctly aligned (the white line on top of the SC-connector shall *not* be visible). A bad or dirty connection may in extreme cases introduce an extra 10dB of loss.

One of the channels is not present at the receiver end.

- a) Clean the optical connectors of that channel
- b) The optical fiber might be damaged. Replace the patch cord with another cord of type SC/UPC-SC/UPC single mode fiber.
- c) You may have exceeded the transmission budget of the optical link for that channel. The individual channels have a small variation in optical power causing the weakest channel to disappear first when the transmission budget is at its limit. Please recalculate your transmission budget and compare to the specifications of the system.

No electrical SDI signal on the receiver side.

If all module LED's on the front panel are green, check that the receiving signal cable is connected to one of the two "digital outputs" and not to the "digital input" connection.

If one of the LED's is red, please refer to the user manual of the module.

No contact with the Gyda system controller on the LAN.

Check that the operator's computer is connected to the LAN.

The ethernet cable pin layout shall be one-to-one if Gyda is connected to a hub or switch. If a computer is connected directly to Gyda, an ethernet cable with twisted pinning must be used.

Go through the enclosed "Gyda Quick Start Guide" to install the module properly.

If LED#2 on Gyda is red, the card has not been assigned an IP-address.

The Gyda system controller is not displaying all sub-racks connected.

Make sure that all sub-rack frames have unique DIP-switch addresses.

The Gyda system controller is adding non-occurring events in the log-file.

Control that the RS-422 bus is terminated with the 110Ω- terminator plug enclosed in the package.

Other requests for assistance:

Network Electronics ASA
Thorøya
3230 Sandefjord, Norway
Phone: +47 33 48 99 99
Fax: +47 33 48 99 98
e-mail: support@network-electronics.com
www.network-electronics.com
Direct Service Phone: +47 90 60 99 99

Declaration of conformity with CE

This apparatus meets the requirements of EN 55103-1 (November 1996) with regard to emissions, and EN 55103-2 (November 1996) with regard to immunity; it thereby complies with the Electromagnetic Compatibility Directive 89/336/EEC.

General environmental requirements for Network flashlink® equipment

1. The equipment will meet the guaranteed performance specification under the following environmental conditions:

- Operating room temperature range 0°C to 40°C
- Operating relative humidity range up to 90% (non-condensing)

2. Electromagnetic compatibility conditions:

- Emissions EN 55103-1 (Directive 89/336/EEC)
- Immunity EN 55103-2 (Directive 89/336/EEC)