

SBC-6504

PICMG 1.0

Single Board Computer

User Manual

2009/11/05



Copyright

Copyright 2009, all rights reserved. This document is copyrighted and all rights are reserved. The information in this document is subject to change without prior notice to make improvements to the products.

This document contains proprietary information and protected by copyright. No part of this document may be reproduced, copied, or translated in any form or any means without prior written permission of the manufacturer.

All trademarks and/or registered trademarks contains in this document are property of their respective owners.

Disclaimer

AICSYS Inc. shall not be liable for any incidental or consequential damages resulting from the performance or use of this product.

AICSYS Inc. does not issue a warranty of any kind, express or implied, including without limitation implied warranties of merchantability or fitness for a particular purpose.

The company has the right to revise the manual or include changes in the specifications of the product described within it at any time without notice and without obligation to notify any person of such revision or changes.

Packing List

Please check the content:

SBC-6504 single board computer	1 PC
Utility CD (including user manual)	1 PC
SATA Cable	1 PC
RS232 DB9 & Printer Port DB25 Cable	1 PC
Jumpers (yellow)	5 PCS

Index

Chapter 1 Product Introduction	7
1.1 Product Overview.....	7
1.2 Product Specification	8
1.3 Mechanical Drawing.....	10
Chapter 2 Hardware Installing	11
2.1 Board Layout.....	11
2.2 Connector List	12
2.3 Jumper List	13
2.4 CPU Installation	14
2.5 Memory Installation	15
2.6 CMOS Setup.....	16
2.7 IDE Interface	17
2.8 Floppy Interface	18
2.9 SATA Interface	19
2.10 Ethernet Interface.....	20
2.11 Display Interface.....	22
2.12 USB Port	23
2.13 Serial Port.....	24
2.14 Power & Fan Connectors.....	26
2.15 Printer Port	28
2.16 SMBus Connector	30
2.17 Keyboard & Mouse Ports.....	31
2.18 Front Panel Connector.....	32
Chapter 3 System Configuration	33
3.1 I/O Port Address Map	33
3.2 Interrupt Controller	34
3.3 Watchdog Timer	35
3.4 SATA Raid Configuration.....	37

Chapter 4 BIOS Setup..... 47

- 4.1 Entering Setup 47
- 4.2 Control Keys 48
- 4.3 Getting Help..... 49
- 4.4 The Main Menu 49
- 4.5 Standard CMOS Setup Menu..... 50
- 4.6 Advanced BIOS Features..... 53
- 4.7 Advanced Chipset Features..... 58
- 4.8 Integrated Peripherals 59
- 4.9 Power Management Setup..... 65
- 4.10 PnP/PCI Configuration Setup..... 69
- 4.11 PC Health Status..... 72
- 4.12 Frequency/Voltage Control..... 74
- 4.13 Load Optimized Defaults 75
- 4.14 Set Supervisor/User Password..... 76
- 4.15 Save & Exit Setup 77
- 4.16 Exit Without Saving 78

(This Page is Left for Blank)

Chapter 1 Product Introduction

1.1 Product Overview

The SBC-6504 PICMG 1.0 full-size Single Board Computer supports Intel® Core™ 2 Duo, Intel® Celeron® 400 Series, Intel® Pentium® 4 processor in the LGA775 Land Grid Array package or Intel® Pentium® D processor (supports 775-Land package) at FSB 533/800 MT/s (133/200 MHz).

The board integrates chipsets Intel® 945GC and ICH7/7R (Optional) that deliver outstanding system performance through high-bandwidth interfaces, multiple I/O functions for interactive applications and various embedded computing solutions. There are two 240-pin unbuffered DIMM sockets for dual channel DDR2-400/533/667 MHz memory, maximum memory capacity up to 2GB.

It also features Gigabit/Fast Ethernet, four serial ATA channels for total four Serial ATA hard drives at maximum transfer rate up to 300MB/sec, and six USB 2.0 compliant interfaces.

1.2 Product Specification

General Specification

Form Factor	PICMG 1.0 full-size single board computer
CPU	Intel® Core 2 Duo, Celeron® 400 series , Pentium® 4 processor and Pentium® D processor (supports 775-Land package)
Front Side Bus	533/800 MT/s (133/200 MHz)
Memory	Two 240-pin unbuffered DDR2 DIMM sockets Maximum to 2GB DDR2 400/533/667 MHz
Chipset	Intel® 945GC & ICH7/ICH7R
BIOS	Phoenix-Award BIOS 8Mbit FWH Flash, DMI, Plug and Play
Watchdog Timer	1~255 seconds; up to 255 levels

Multiple I/O Ports

Chipset	Intel ICH7 integrated with Winbond W83627HG
Enhanced IDE	1 x 40-pin IDE supports ATA100 up to 2 devices
SATA	4 x SATA ports support 300MB/s transfer rate Optional SATA RAID 0/1/5/10 by ICH7R
Serial Port	1 x RS232 & 1 x jumper selectable RS232/422/485 serial ports
Hardware monitor	System temperature, voltage, fan speed, auto throttling control when CPU overheat
Floppy	1 x 34-pin FDD port, up to 2 devices
USB	Six USB ports with fuse protection and complies with USB Spec. Rev. 2.0
Keyboard/Mouse	1 x internal PS/2 keyboard & mouse port

Display

Graphic Engine	Intel 945GC integrated GMA (Graphic Media Accelerator) 950
Frame Buffer	Up to 224MB shared with system memory
Display Type	VGA D-sub 15-pin output

Ethernet

Controller	Realtek RTL8111B Gigabit Ethernet Controllers
Speed	10/100/1000Mbps

Power & Environment

Power Requirement	Standard ATX power from backplane
Dimension	338(L) x 122(H)mm
Temperature	Operating temperature: 0°C ~ 60°C
Humidity	0 ~ 90% relative humidity, no condensing

1.3 Mechanical Drawing

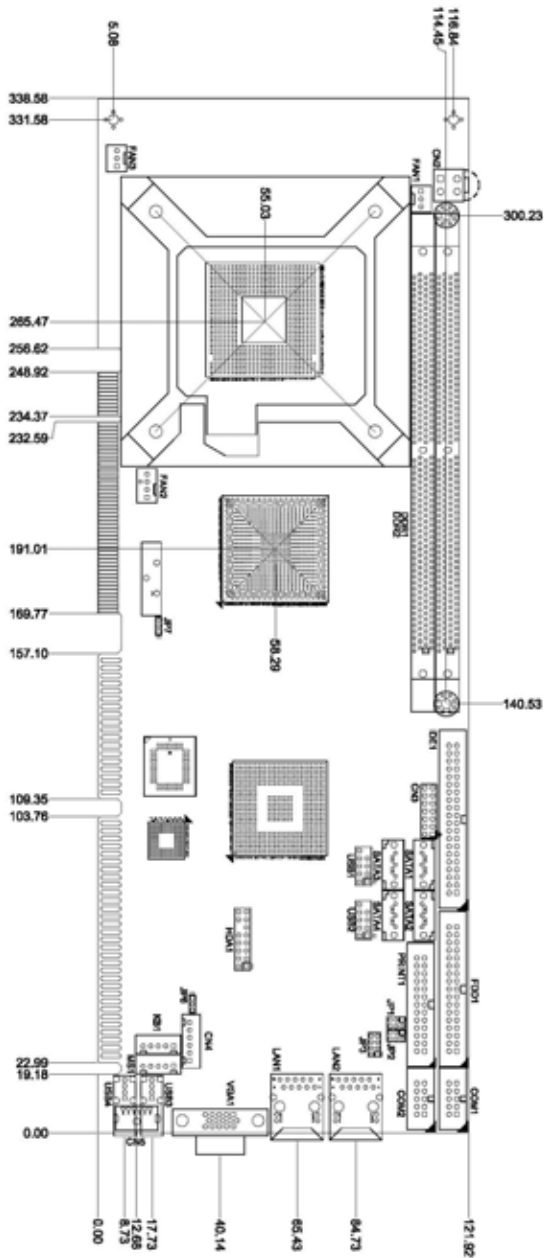

Chapter 2 Hardware Installing

2.1 Board Layout

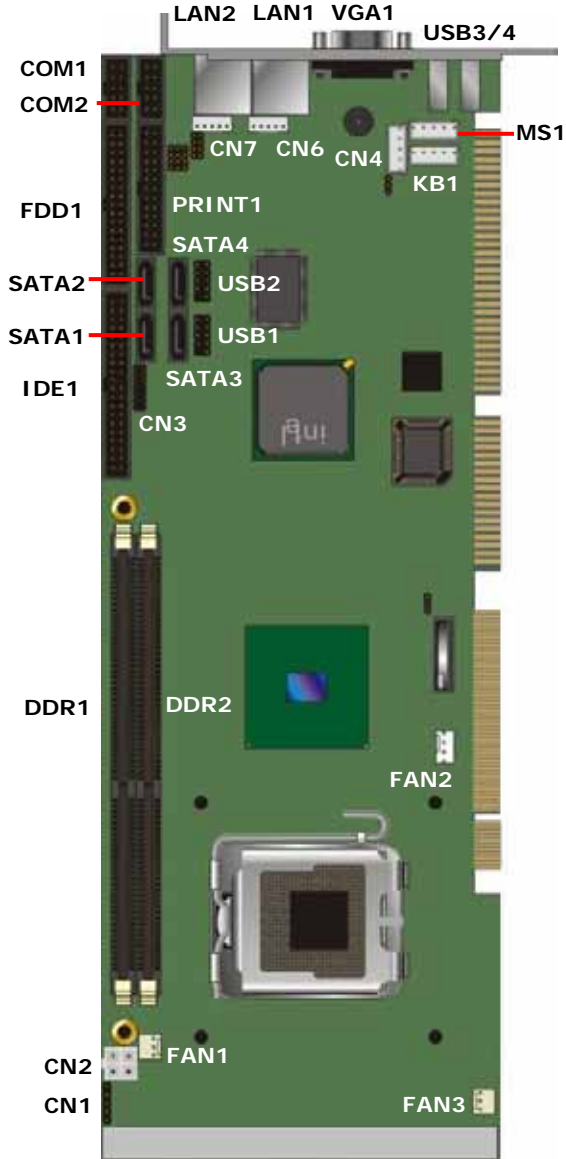

2.2 Connector List

Connector	Description
CN1	SM BUS Connector
CN7	LAN2 Link/Active & Speed LED Connector
CN2	ATX 4 Pin 12V In
CN3	Front Panel Connector
CN4	ACPI Connector
CN5	PS/2 KB/MS Connector (Optional)
IDE1	Parallel IDE Connector
FDD1	Floppy Connector
PRINT1	Printer Port Connector
COM1	Serial Port1 Connector
COM2	Serial Port2 Connector
USB1	USB Port5/6 Connector
USB2	USB Port3/4 Connector
USB3/4	USB Port1/2 Connector
CN6	LAN1 Link/Active & Speed LED Connector
LAN1	LAN1 Connector
LAN2	LAN2 Connector
VGA1	VGA Connector
DDR1/2	DDRII Long-DIMM Sockets
FAN1	System FAN Connector 1
FAN2	CPU FAN Connector
FAN3	System FAN Connector 2
KB1	Internal PS/2 Keyboard Connector
MS1	Internal PS/2 Mouse Connector
SATA1~4	Serial ATA Port Connectors

2.3 Jumper List

Jumper	Default		Setting
JP1	COM2 Mode Select	COM2 Pin 1: DCD	Short 3-5
		COM2 Pin 8: RI	Short 4-6
JP2	COM2 Mode Select	COM2 Pin 1: DCD	Short 3-5
		COM2 Pin 8: RI	Short 4-6
JP3	COM2 Mode Select : RS-232		Short 1-2
JP6	ATX Auto Power On/Off : Disable		Short 1-2
JP7	Clear CMOS Setting : Normal		Short 1-2

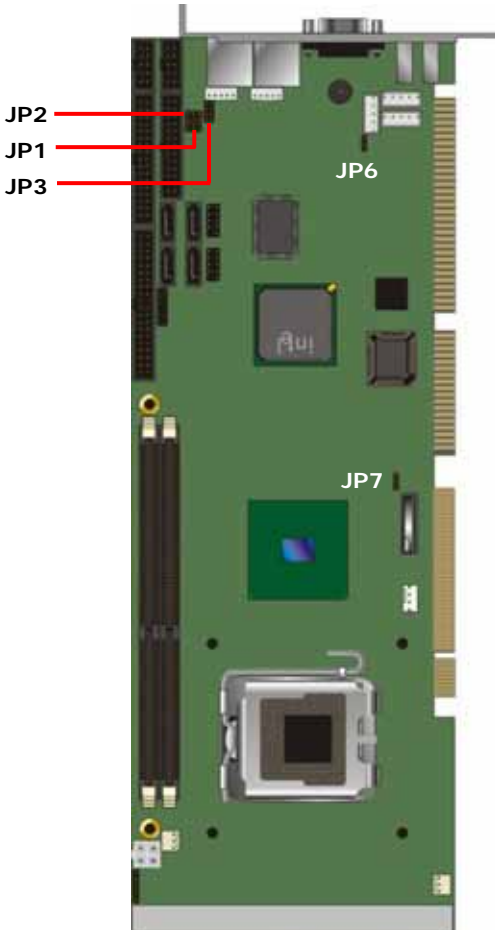

2.4 CPU Installation

The board supports Intel Desktop Processors as:

Socket Type	LGA775
Front Side Bus	533/800MHz
Generation	Intel® Core 2 Duo, Celeron® 400 series , Pentium® 4 processor and Pentium® D processor

Please follow the installation steps:

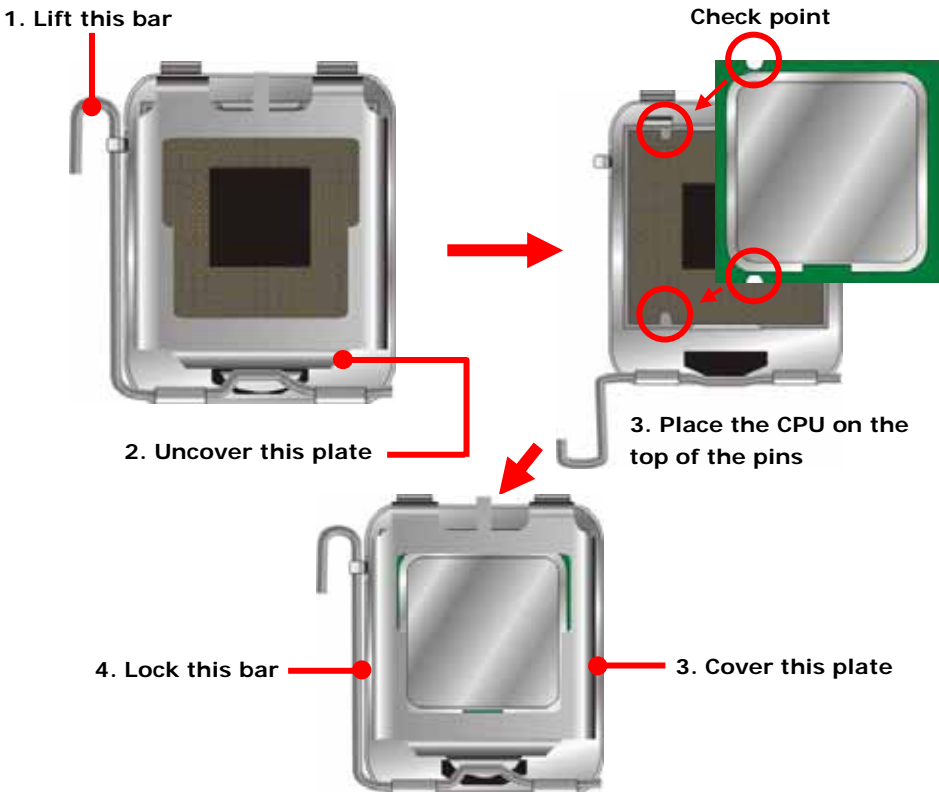

Notice: Please place the CPU on the pins tenderly to avoid bending the pins

2.5 Memory Installation

The board supports four 240-pin DDR2 DIMM memory sockets with maximum memory capacity up to 2GB.

Please follow steps below to install the memory modules:

Push down latches on each side of the DIMM socket.

Align the memory module with the socket that notches of memory module must match the socket keys for a correct installation.

Install the memory module into the socket and push it firmly down until it is fully seated. The socket latches are levered upwards and clipped on to the edges of the DIMM.

Install any remaining DIMM modules.

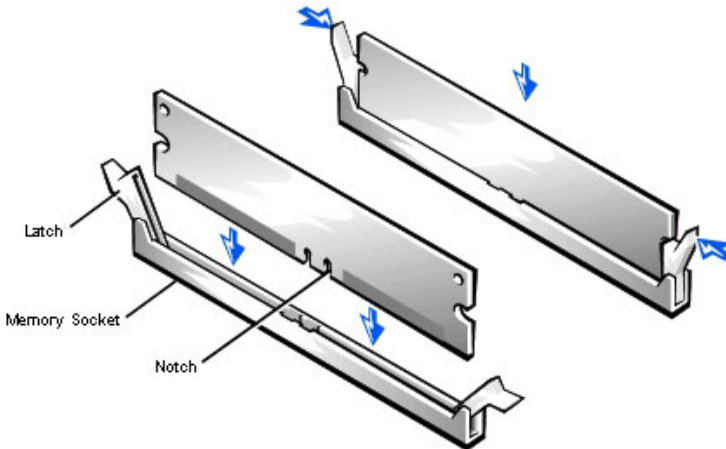

2.6 CMOS Setup

The board's data of CMOS can be setting in BIOS. If the board refuses to boot due to inappropriate CMOS settings, here is how to proceed to clear (reset) the CMOS to its default values.

Jumper: JP7

Type: Onboard 3-pin jumper

JP7	Mode
1-2	Normal Operation S
2-3	Clear CMO
Default setting	

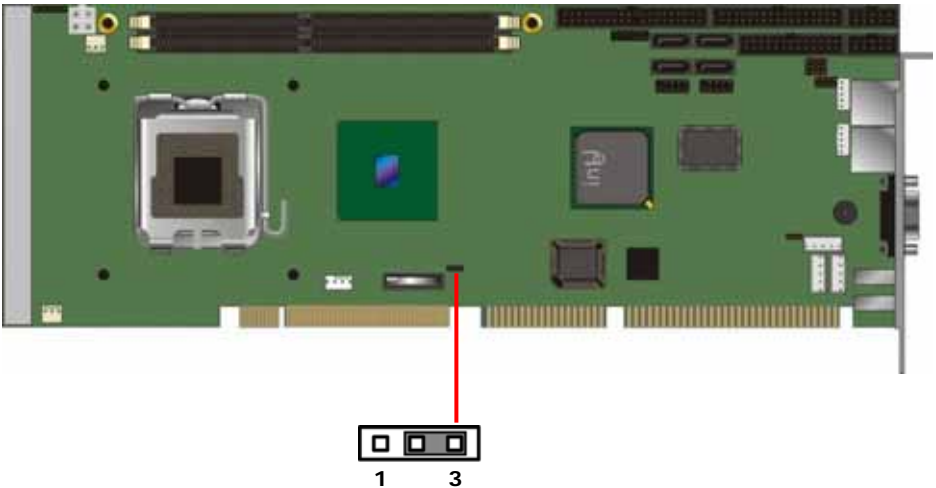

2.7 IDE Interface

IDE1 is a 40-pin IDE interface connector for standard 3.5" IDE device.

Pin	Signal	Pin	Signal	Pin	Signal
1	Reset #	2	GND	3	Data 7
4	Data 8	5	Data 6	6	Data 9
7	Data 5	8	Data 10	9	Data 4
10	Data 11	11	Data 3	12	Data 12
13	Data 2	14	Data 13	15	Data 1
16	Data 14	17	Data 0	18	Data 15
19	GND	20	NC	21	DREG#
22	GND	23	IOW #	24	GND
25	IOR #	26	GND	27	IOCHRDY
28	CSEL	29	DACK#	30	GND
31	Interrupt	32	NC	33	SA1
34	PDIAG#	35	SA0	36	SA2
37	HDC CS0 #	38	HDC CSI #	39	HDD Active #
40	GND				



2.8 Floppy Interface

The board provides a 34-pin header type connector, FDD1, supporting up to two floppy drives. The floppy drives may be any one of the following types: 5.25" 360KB/1.2MB and 3.5" 720KB/1.44MB/2.88MB.

Pin	Signal	Pin	Signal	Pin	Signal
1	GND	2	Drive Density Select	3	GND
4	No connector	5	GND	6	No connector
7	GND	8	Index#	9	GND
10	Motor enable A#	11	GND	12	No connector
13	GND	14	Drive select A#	15	GND
16	No connector	17	GND	18	Direction#
19	GND	20	STEP#	21	GND
22	Write data#	23	GND	24	Write gate#
25	GND	26	Track 0 #	27	GND
28	Write protect#	29	No connector	30	Read data#
31	GND	32	Head selection#	33	No connector
34	Disk change#				

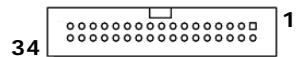

2.9 SATA Interface

These SATA connectors are for high-speed SATA interface ports and they can be connected to hard disk devices.

Pin	Signal
1	GND
2	SATA_TX+
3	SATA_TX-
4	GND
5	SATA_RX-
6	SATA_RX+
7	GND

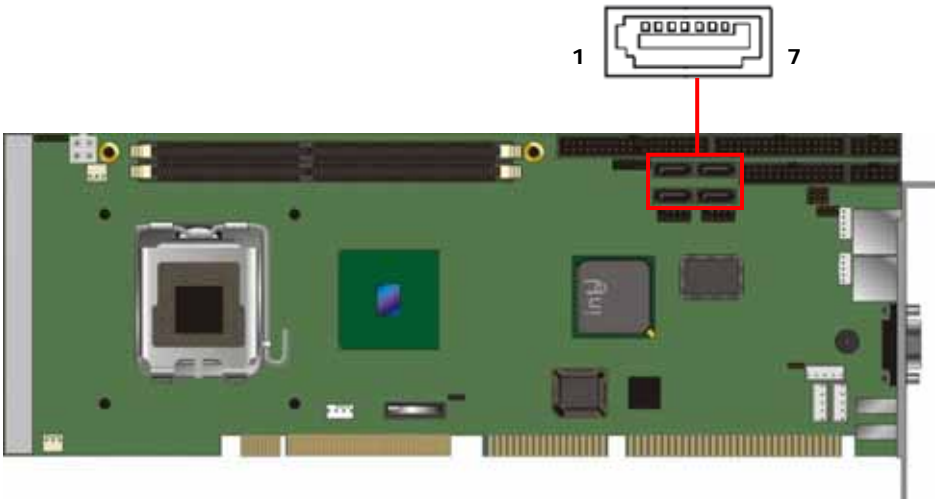

2.10 Ethernet Interface

The board is equipped with two high performance Plug and Play Ethernet interface fully compliant with the IEEE 802.3 standard. To connect the board to 10-Base-T, 100-Base-T or 1000 Base-T hub, just plug one end of cable to the Ethernet connector and connect the other end (phone jack) to a 10-Base-T, 100-Base-T or 1000 Base-T hub.

Pin	Signal
1	RJ-1(For 1000 base T-Only)
2	RJ-1(For 1000 base T-Only)
3	Rx- (Data reception negative)
4	RJ-1(For 1000 base T-Only)
5	RJ-1(For 1000 base T-Only)
6	Rx+ (Data reception positive)
7	Tx- (Data transmission negative)
8	Tx+ (Data transmission positive)
A	Active LED
B	100 LAN LED(Green)/ 1000 LAN LED(Orange)



LAN1/LAN2 Link/Active & Speed LED Connectors (CN6, CN7)

Pin	Signal
1	Link/Active LED (+)
2	Link/Active LED (-)
3	Speed LED-10/100, Low Active
4	+ 3.3V
5	Speed LED-1000, Low Active

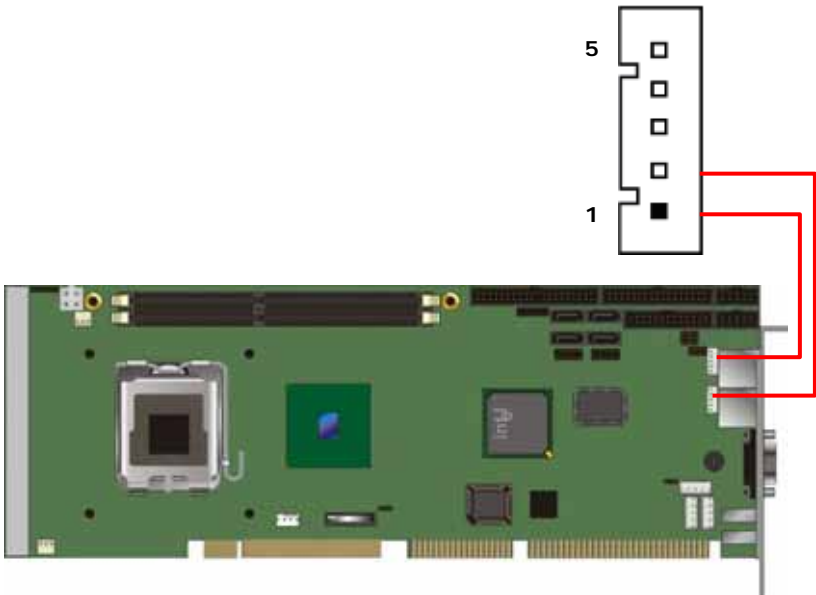

2.11 Display Interface

The VGA connector **VGA1** is a standard 15-pin connector commonly used for the CRT VGA display.

Pin	Signal
1	Red
2	Green
3	Blue
4	N.C
5	Ground
6	Ground
7	Ground
8	Ground(GND)
9	+5V
10	Ground (GND)
11	N.C
12	DDC DATA
13	Horizontal Sync
14	Vertical Sync
15	DDC CLK



2.12 USB Port

The 4-pin standard Universal Serial Bus (USB) port connector on the board is for the installation of peripherals supporting the USB interface.

Connector: USB1/2

Pin	Signal	Pin	Signal
1	+5V	2	+5V
3	USB D4-	4	USB D5-
5	USB D4+	6	USB D5+
7	Ground (GND)	8	Ground (GND)
9	NC	10	Ground (GND)

Connector: USB3/4

Pin	Signal
1	USB POWER
2	USB -
3	USB +
4	GND

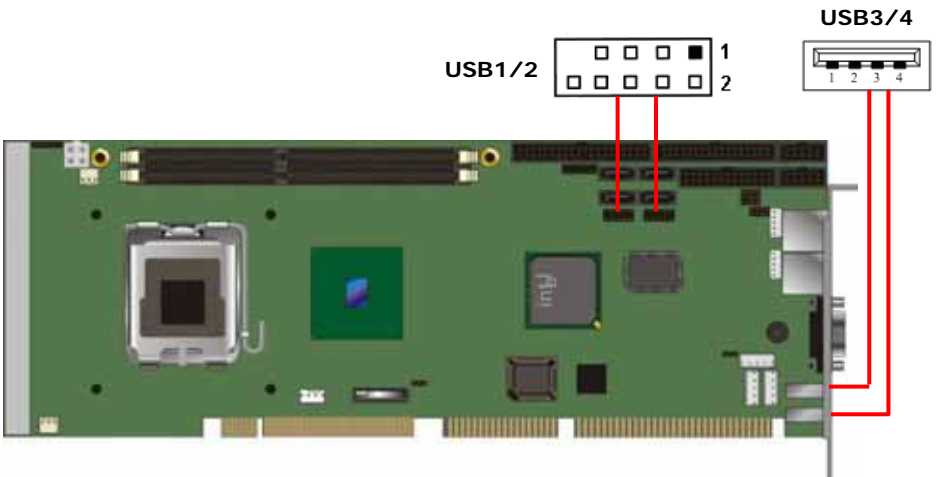

2.13 Serial Port

The serial interface for the board consists of COM1 port (COM1) support for RS-232 and COM2 (COM2) for RS-232/RS422/RS485.







Please refer to the RS-232 pin assignment as listed below:

Connector: COM1

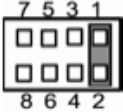
Pin	Signal	Pin	Signal
1	Data Carrier Detect (DCD)	2	Data Set Ready (DSR)
3	Receive Data (RXD)	4	Request to Send (RTS)
5	Transmit Data (TXD)	6	Clear to Send (CTS)
7	Data Terminal Ready (DTR)	8	Ring Indicator (RI)
9	Ground (GND)	10	Ground (GND)

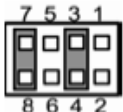
Connector: COM2

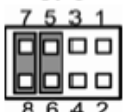
Pin #	Signal Name	
	RS-422	RS-485
1	TX-	DATA-
2	No connector	No connector
3	TX+	DATA+
4	No connector	No connector
5	RX+	No connector
6	No connector	No connector
7	RX-	No connector
8	No connector	No connector
9	GND	GND
10	GND	GND

Description	Function	Jumper Setting		
COM2	RS-232 (Default)	JP3 	JP2 	JP1 
	RS-422	JP3 	JP2 	JP1 
	RS-485	JP3 	JP2 	JP1 

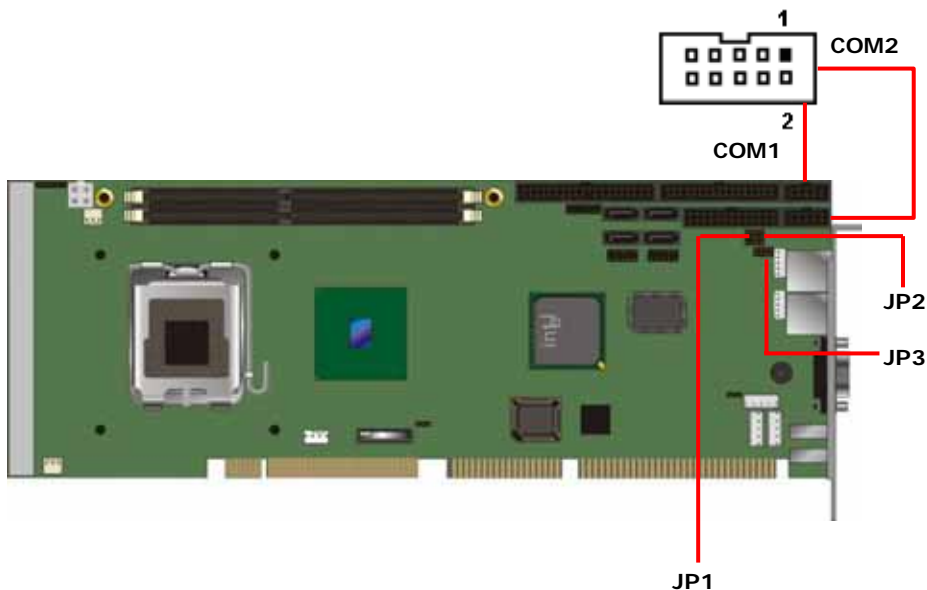

2.14 Power & Fan Connectors

Connect the power cable to **CN2** for +12V ATX power supply

Pin	Signal
1	GND
2	GND
3	+12V
4	+12V

CN4 is a 6-pin header connector that provides ACPI interface.

Pin	Signal
1	EXTSMI
2	GND
3	Power Button
4	GND
5	PSON
6	+5VSB

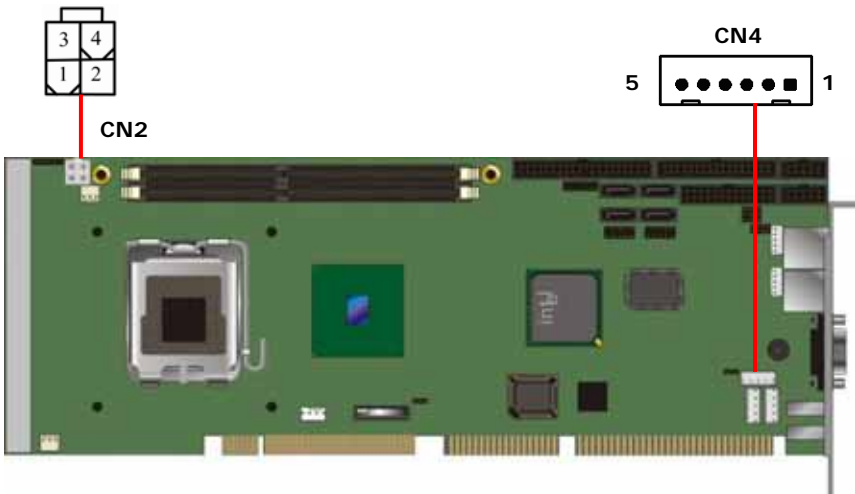

You can connect the system cooling fan cable to **FAN1**, **FAN3**

Pin	Signal
1	Ground
2	+12V
3	Sensor

You can connect the CPU cooling fan cable to **FAN2**. It is for CPU cooling fan power.

Pin	Signal
1	GND
2	+12V
3	Sensor
4	NC

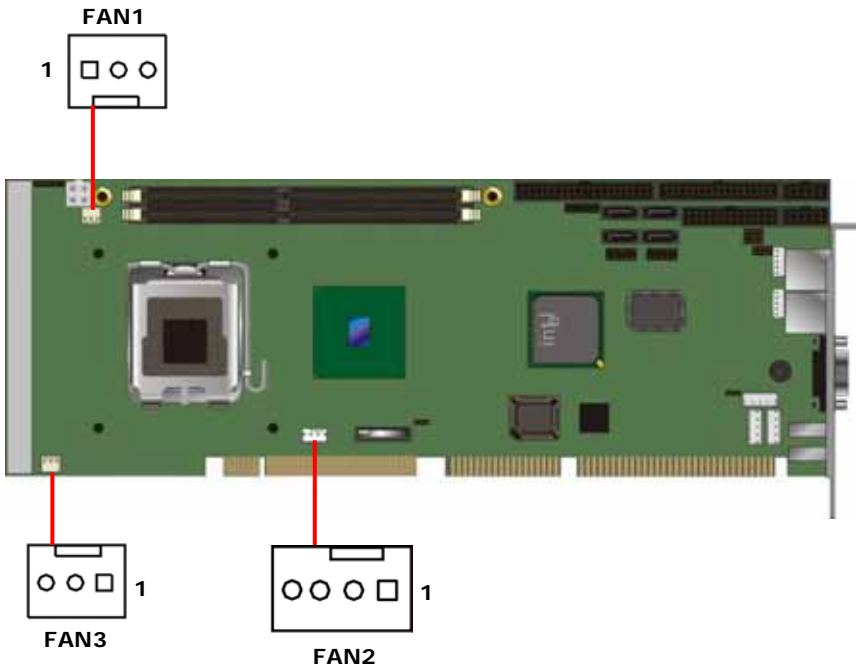

2.15 Printer Port

This board has a multi-mode parallel port to support:

1. Standard Mode:

IBM PC/XT, PC/AT and PS/2™ are compatible with bi-directional parallel port.

2. Enhanced Mode:

Enhance parallel port (EPP) is compatible with EPP 1.7 and EPP 1.9 (IEEE 1284 compliant).

3. High Speed Mode:

Microsoft and Hewlett Packard extended capabilities port (ECP) is IEEE 1284 compliant.

Pin	Signal	Pin	Signal
1	Strobe#	2	Auto Form Feed#
3	Data 0	4	Error#
5	Data 1	6	Initialize#
7	Data 2	8	Printer Select In#
9	Data 3	10	GND
11	Data 4	12	GND
13	Data 5	14	GND
15	Data 6	16	GND
17	Data 7	18	GND
19	Acknowledge#	20	GND
21	Busy	22	GND
23	Paper Empty#	24	GND
25	Printer Select	26	GND

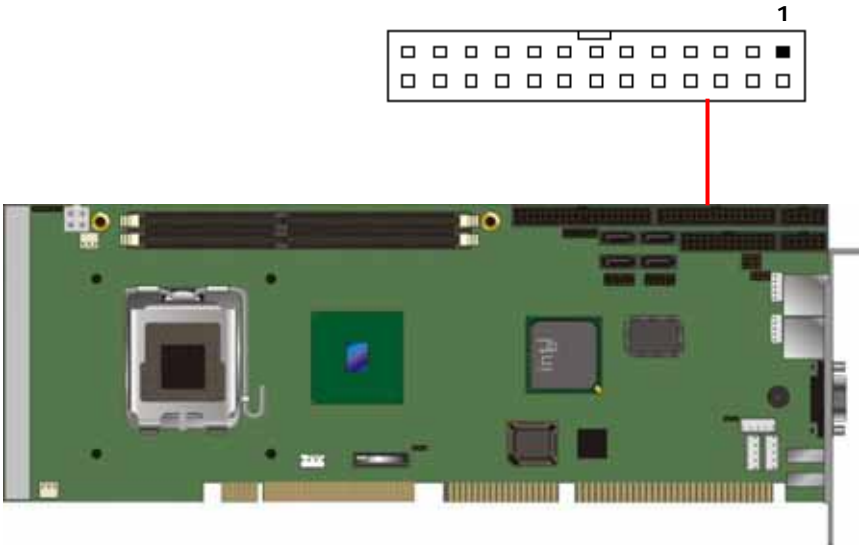

2.16 SMBus Connector

This connector CN1 is for SMBUS interface support.

Pin	Signal
1	SMBUS_CLOCK
2	NC
3	GND
4	SMBUS_DATA
5	+5V

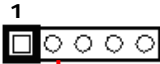

2.17 Keyboard & Mouse Ports

The board provides the Keyboard (KB1)/ Mouse (MS1) interface with a 5-pin connector.

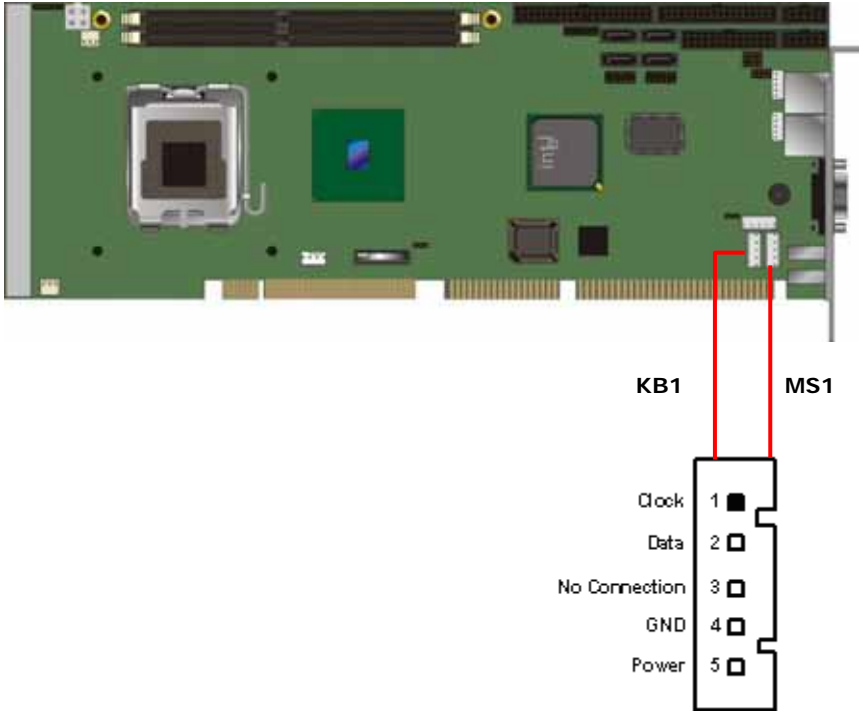

2.18 Front Panel Connector

Power LED

This 3-pin connector named as Pin 1, 3 and Pin 5 connect the system power LED indicator to such a switch on the case. Pin 1 is assigned as +, and Pin 3, Pin 5 as -. The Power LED lights up when the system is powered ON.

External Speaker and Internal Buzzer Connector

Pin 2, 4, 6 and 8 can be connected to the case-mounted speaker unit or internal buzzer. While connecting the CPU card to an internal buzzer, please short pins 2-4; while connecting to an external speaker, you need to set pins 2-4 to Open and connect the speaker cable to pin 8 (+) and pin 6 (-).

ATX Power On/Off Button

This 2-pin connector named as Pin 9 and 10 connect the front panel's ATX power button to the CPU card, which allows users to control ATX power supply to be power on/off.

System Reset Switch

Pin 11 and 12 can be connected to the case-mounted reset switch that reboots your computer, not turns OFF the power switch. It is a better way to reboot your system for a longer life of the system's power supply.

HDD Activity LED

This connection is linked to hard drive activity LED on the control panel. LED flashes when HDD is being accessed. Pin 13 and 14 connect the hard disk drive to the front panel HDD LED, Pin 13 assigned as -, and Pin 14 as +.

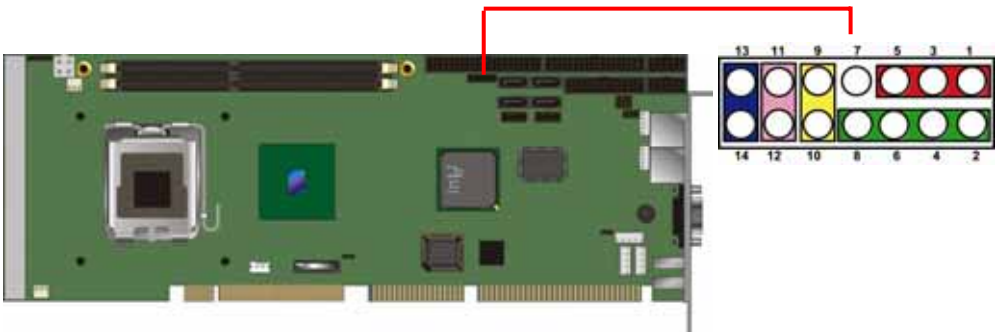

Chapter 3 System Configuration

3.1 I/O Port Address Map

The Intel® Core™ 2 Duo Processor, Intel® Pentium® D Processor, Intel® Celeron® Processor can communicate via I/O ports. There are total 1KB port addresses available for assignment to other devices via I/O expansion cards.

[00000000 - 0000000F]	Direct memory access controller
[00000000 - 00000CF7]	PCI bus
[00000010 - 0000001F]	Motherboard resources
[00000020 - 00000021]	Programmable interrupt controller
[00000022 - 0000003F]	Motherboard resources
[00000040 - 00000043]	System timer
[00000044 - 0000005F]	Motherboard resources
[00000060 - 00000060]	Standard 101/102-Key or Microsoft Natural PS/2 Keyboard
[00000061 - 00000061]	System speaker
[00000062 - 00000063]	Motherboard resources
[00000064 - 00000064]	Standard 101/102-Key or Microsoft Natural PS/2 Keyboard
[00000065 - 0000006F]	Motherboard resources
[00000070 - 00000073]	System CMOS/real time clock
[00000074 - 0000007F]	Motherboard resources
[00000080 - 00000090]	Direct memory access controller
[00000091 - 00000093]	Motherboard resources
[00000094 - 0000009F]	Direct memory access controller
[000000A0 - 000000A1]	Programmable interrupt controller
[000000A2 - 000000BF]	Motherboard resources
[000000C0 - 000000DF]	Direct memory access controller
[000000E0 - 000000EF]	Motherboard resources
[000000F0 - 000000FF]	Numeric data processor
[00000170 - 00000177]	Secondary IDE Channel
[000001F0 - 000001F7]	Primary IDE Channel
[00000274 - 00000277]	ISAPNP Read Data Port
[00000279 - 00000279]	ISAPNP Read Data Port
[00000294 - 00000297]	Motherboard resources
[000002F8 - 000002FF]	Communications Port (COM2)
[00000376 - 00000376]	Secondary IDE Channel
[00000378 - 0000037F]	Printer Port (LPT1)
[000003B0 - 000003BB]	Intel(R) 82945G Express Chipset Family
[000003C0 - 000003DF]	Intel(R) 82945G Express Chipset Family
[000003F0 - 000003F5]	Standard floppy disk controller
[000003F6 - 000003F6]	Primary IDE Channel
[000003F7 - 000003F7]	Standard floppy disk controller
[000003F8 - 000003FF]	Communications Port (COM1)

3.2 Interrupt Controller

The board is a 100% PC compatible control board. It consists of 16 interrupt request lines, and four out of them can be programmable. The mapping list of the 16 interrupt request lines is shown as the following table.

IRQ	Parity check error
IRQ0	System timer
IRQ1	Standard 101/102-Key or Microsoft Natural PS/2 Keyboard
IRQ2	Interrupt rerouting from IRQ8 through IRQ15
IRQ3	Serial port #2
IRQ4	Serial port #1
IRQ6	Standard floppy disk controller
IRQ7	Parallel port
IRQ8	System CMOS/real time clock
IRQ9	Microsoft ACPI-Compliant System
IRQ12	PS/2 Compatible Mouse
IRQ13	Numeric data processor
IRQ14	Primary IDE channel
IRQ15	Secondary IDE channel

3.3 Watchdog Timer

Watchdog Timer Setting

After the system stops working for a while, it can be auto-reset by the Watchdog Timer. The integrated Watchdog Timer can be set up in the system reset mode by program.

Programming Guide

Start

↓

Un-Lock WDT:

O 2E 87 ; Un-lock super I/O

O 2E 87 ; Un-lock super I/O

↓

Select Logic device:

O 2E 07

O 2F 08

↓

Activate WDT:

O 2E 30

O 2F 01

↓

Set Second or Minute:

O 2E F5

O 2F N N=00 or 08 (Note#)

↓

Set base timer:

O 2E F6

O 2F M=00, 01, 02,...FF(Hex) ,Value=0 to 255

↓

WDT counting re-set timer:

O 2E F6

O 2F M; M=00, 01, 02,...FF

; IF to disable WDT:

O 2E 30

O 2F 00; Can be disable at any time

- Timeout Value Range
 - 1 to 255
 - Minute / Second

● Program Sample

2E, 87	
2E, 87	
2E, 07	
2F, 08	Logical Device 8
2E, 30	Activate
2F, 01	
2E, F5	
2F, N	Set Minute or Second N=08 (Min),00(Sec)
2E, F6	
2F, M	Set Value M = 00 ~ FF

Note#:

N=00

M= 00h: Time-out Disable

01h: Time-out occurs after 1 second

02h: Time-out occurs after 2 second

03h: Time-out occurs after 3 second

.....

FFh: Time-out occurs after 255 second

N=08

M= 00h: Time-out Disable

01h: Time-out occurs after 1 minute

02h: Time-out occurs after 2 minutes

03h: Time-out occurs after 3 minutes

.....

FFh: Time-out occurs after 255 minutes

3.4 SATA Raid Configuration

Configuring SATA Hard Drive(s) for RAID Function (Controller: Intel® ICH7R only)

Please follow up the steps below to configure SATA hard drive(s):

- (1) Install SATA hard drive(s) in your system.
- (2) Enter the BIOS Setup to configure SATA controller mode and boot sequence.
- (3) Configure RAID by the RAID BIOS.
- (4) Create a floppy disk for the SATA controller driver.
- (5) Install the SATA controller driver during the OS installation.

Before you begin the SATA configuration, please prepare:

- (a) Two SATA hard drives (to ensure optimal performance, it is recommended that you use two hard drives with identical model and capacity).
- (b) An empty formatted floppy disk
- (c) Windows XP setup disk

(1) Installing SATA hard drive(s) in your system

Connect one end of the SATA signal cable to the rear of the SATA hard drive, and the other end to available SATA port(s) on the board. Then, connect the power connector of power supply to the hard drive.

(2) Configuring SATA controller mode and boot sequence by the BIOS Setup

You have to make sure whether the SATA controller is configured correctly by system BIOS Setup and set up BIOS boot sequence for the SATA hard drive(s).

1. Turn on your system and press the Del button to enter BIOS Setup during running POST (Power-On Self Test). If you want to create RAID, just select **RAID** for **SATA Mode** (default **IDE**) under the **Integrated Peripherals** menu.

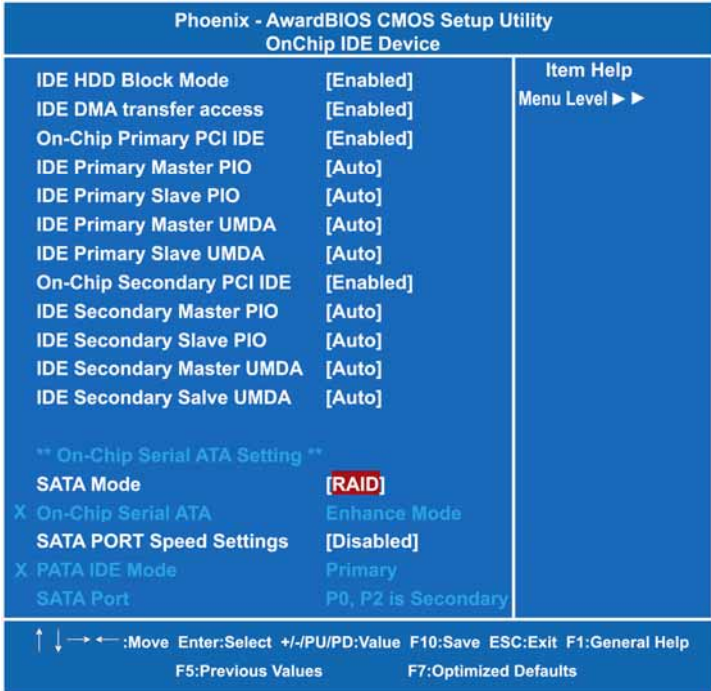

2. Turn on your system and press the Del button to enter BIOS Setup during running POST (Power-On Self Test). If you want to create RAID, just select **RAID** for **SATA Mode** (default **IDE**) under the **Integrated Peripherals** menu.

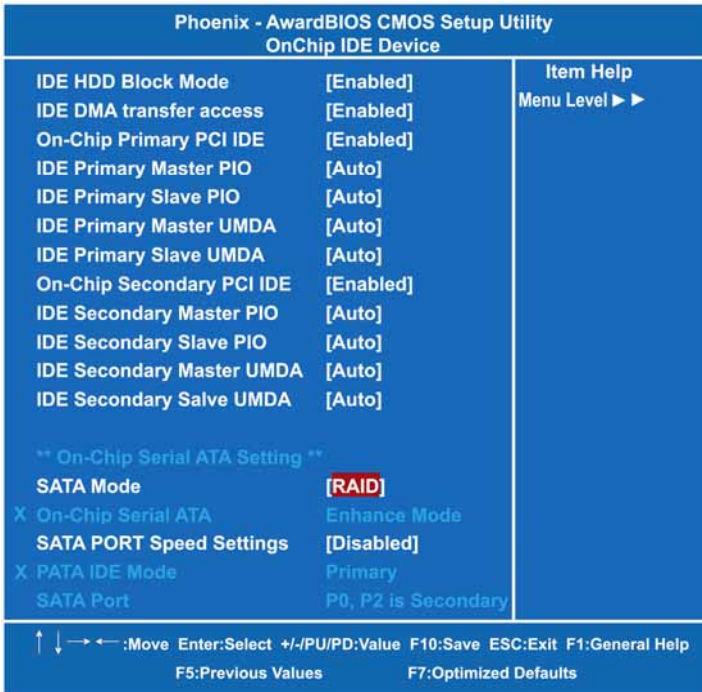

- Set **CDROM** for **First Boot Device** under the **Advanced BIOS Features** menu to boot CD-ROM after system restarts
- Save and exit the BIOS Setup.
- Configuring RAID by the RAID BIOS

Enter the RAID BIOS setup utility to configure a RAID array.

After the POST memory testing and before the operating system booting, a message "*Press <Ctrl-I> to enter Configuration Utility*" shows up, accordingly, press <CTRL+ I> to enter the RAID BIOS setup utility.



After you press <CTRL+ I>, the **Create RAID Volume** screen will appear. If you want to create a RAID array, select the **Create RAID Volume** option in the Main Menu and press ENTER.

```

Intel (R) Matrix Storage Manager option ROM v5.7.0.1007 ICH7MR
Copyright (C) 2003-05 Intel Corporation. All Rights Reserved.

-----[MAIN MENU]-----
1. Create RAID Volume
2. Delete RAID Volume
3. Reset Disks to Non-RAID
4. Exit

-----[DISK/VOLUME INFORMATION]-----
RAID Volumes:
ID   Name      Level      Strip Size   Status      Bootable
0    Volume0   RAID1(Mirror)  N/A  74.5GB    Degraded   Yes

Physical Disks:
Port Drive Model   Serial #      Size      Type/Status(Vol ID)
0    ST380815AS   6Q221RYL     74.5GB    Member Disk(0)
2    ST3808110AS  4LR1S469     74.5GB    Non-RAID Disk

Press <CTRL-I> to enter Configuration Utility..

[↑ ↓]-Select  [ESC]-Exit    [ENTER]- Select Menu
    
```

After entering the **CREAT VOLUME MENU** screen, you can type the disk array name with 1~16 letters (letters cannot be special characters) in the item “Name”. When finished, press ENTER to select a RAID level. There are two RAID levels, RAID0 and RAID1. Select a RAID level and press ENTER.

```

Intel (R) Matrix Storage Manager option ROM v5.7.0.1007 ICH7MR
Copyright (C) 2003-05 Intel Corporation. All Rights Reserved.

-----[CREAT VOLUME MENU]-----
Name: Volume
RAID Level: RAID0 (Stripe)
Disks: Select Disks
Stripe Size: 128KB
Capacity: 149.1 GB
          Creat Volume
          -----[HELP]-----

Choose the RAID level best suited to your usage model.

RAID0 -- Data striped accross multiple physical drives for performance.
RAID1 -- Data mirrored across multiple physical drives for redundancy.

[↑ ↓]Change  [TAB]-Next  [ESC]-Previous Menu  [ENTER]- Select
    
```

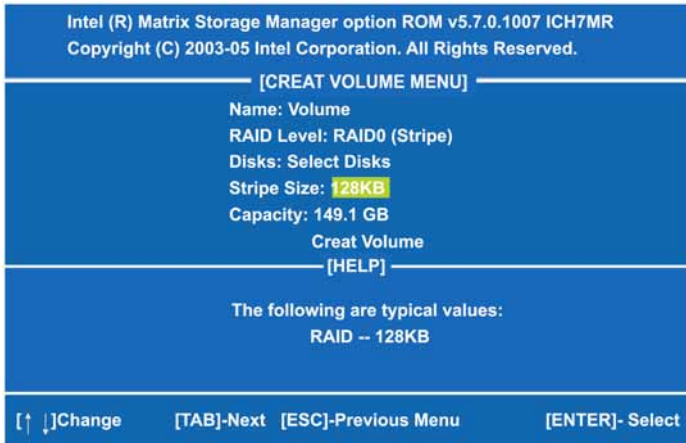

Set the stripe block size. The *KB* is the standard unit of stripe block size. The stripe block size can be 4KB to 128KB. After the setting, press ENTER for the array capacity.

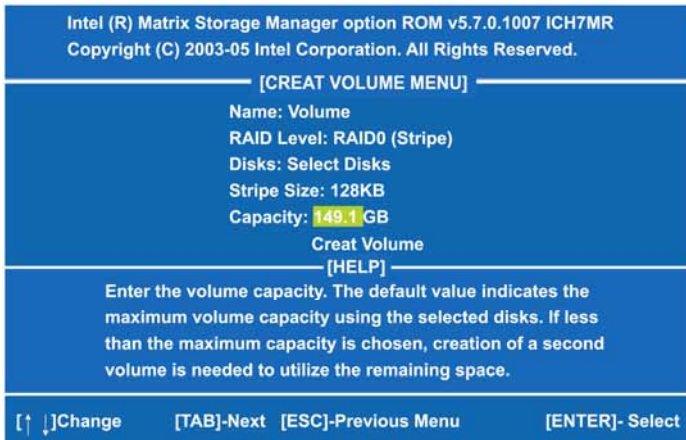

After setting all the items on the menu, select **Create Volume** and press ENTER (as Figure 7) to start creating the RAID array.

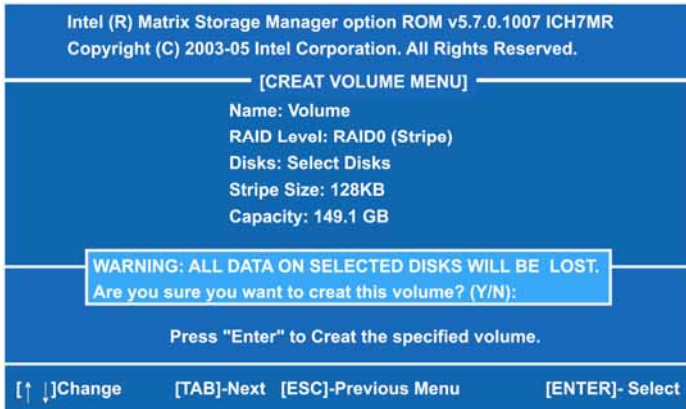

When prompting the confirmation, press "Y" to create this volume, or "N" to cancel the creation.



After the creation is completed, you can see detailed information about the RAID Array in the DISK/VOLUME INFORMATION section, including RAID mode, disk block size, disk name, and disk capacity, etc.

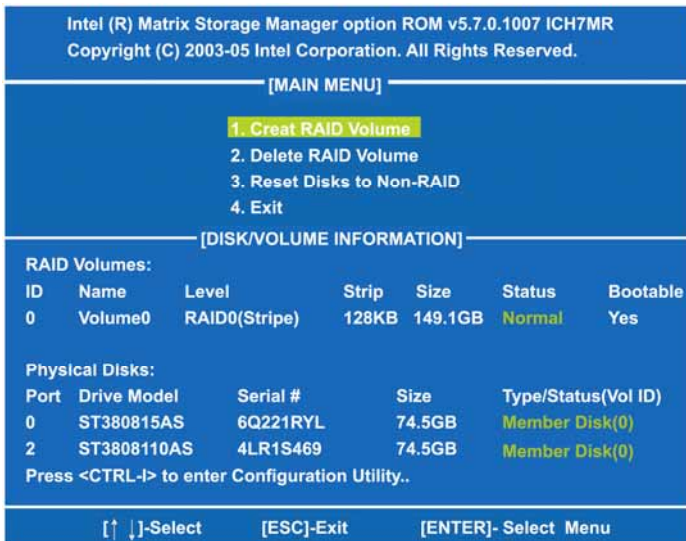

Delete RAID Volume

If you want to delete a RAID volume, select the **Delete RAID Volume** option in Main Menu. Press ENTER and follow on-screen instructions.

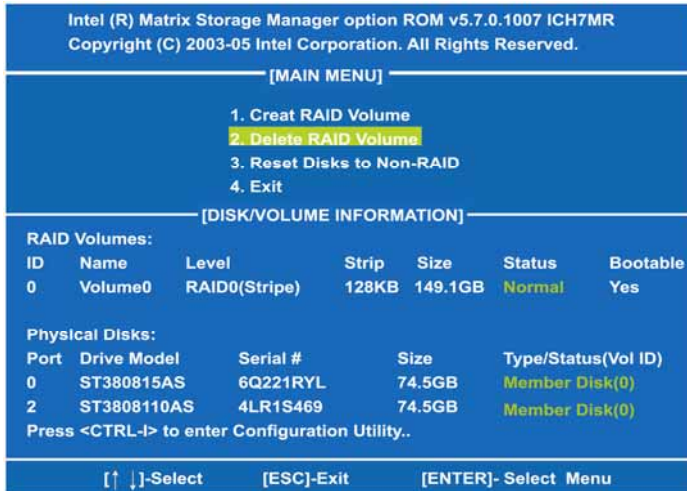

Please press [ESC] to exit the ICH7MR RAID BIOS utility.

Now, you can proceed to install a SATA controller and the operating system.

Making a SATA Driver Disk

To install the operating system onto a serial ATA hard disk successfully, you need to install the SATA controller driver during the OS installation. Without the driver, the hard disk may not be recognized during the Windows setup process. First of all, please format a blank floppy disk. Secondly, follow up these steps below to produce a SATA driver disk.

Users can insert the Driver CD and the formatted blank floppy disk in another system. And then, please execute the f6flpy32.exe file in the folder of the Driver CD.

Note Please execute the f6flpy64.exe file, if installing 64-bit Windows Operating System.



f6flpy32.exe

When this screen pops out, please click the “**CONFIRM**” button.



When the Driver is written to the floppy disk, the SATA driver disk is completed.

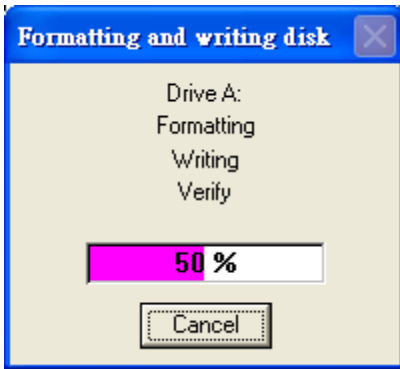

Installing the SATA controller driver during the OS installation

Now, the SATA driver disk is ready, and BIOS settings configured, you can proceed to install Windows XP onto your SATA hard drive using the SATA driver. Here is an example for Windows XP installation.

Restart your system to boot the Windows XP Setup disk, and press F6 button as soon as you see the message "*Press F6 if you need to install a 3rd party SCSI or RAID driver*" (as Figure 11). After pressing the F6 button, there will be a few moments for some files being loaded before next screen appears.



When you see the screen below, insert the floppy disk containing the SATA driver and press "S".



If the Setup correctly recognizes the driver of the floppy disk, a controller menu (as Figure 13) will appear below. Use the ARROW keys to select **Intel(R) 82801GR/GH SATA RAID Controller (Desktop ICH7R/DH)** and press ENTER. Then it will begin to load the SATA driver from the floppy disk.



Note If a message on the screen saying that one or some file(s) cannot be found, please check the floppy disk or copy the correct SATA driver again from the driver CD.

When the screen appears as below, press ENTER to continue installing the SATA driver through the floppy disk. It will take about one minute to finish the driver installation.



After the SATA controller driver installation is completed, you can proceed to install the Windows XP

Chapter 4 BIOS Setup

The Phoenix-Award BIOS provides users with a built-in Setup program to modify basic system configuration. All configured parameters are stored in a battery-backed-up RAM (CMOS RAM) to save the Setup information whenever the power is turned off.

4.1 Entering Setup

There are two ways to enter the Setup program. You may either turn ON the computer and press immediately, or press the and/or <Ctrl>, <Alt>, and <Esc> keys simultaneously when the following message appears at the bottom of the screen during POST (Power on Self Test).

TO ENTER SETUP PRESS DEL KEY

If the message disappears before you respond and you still want to enter Setup, please restart the system to try it again. Turning the system power OFF and ON, pressing the "RESET" button on the system case or simultaneously pressing <Ctrl>, <Alt>, and keys can restart the system. If you do not press keys at the right time and the system doesn't boot, an error message will pop out to prompt you the following information:

**PRESS <F1> TO CONTINUE, <CTRL-ALT-ESC> OR TO ENTER
SETUP**

4.2 Control Keys

Up arrow	Move cursor to the previous item
Down arrow	Move cursor to the next item
Left arrow	Move cursor to the item on the left hand
Right arrow	Move to the item in the right hand
Esc key	Main Menu -- Quit and delete changes into CMOS Status Page Setup Menu and Option Page Setup Menu -- Exit current page and return to Main Menu
PgUp/"+" key	Increase the numeric value or make changes
PgDn/"-" key	Decrease the numeric value or make changes
F1 key	General help, only for Status Page Setup Menu and Option Page Setup Menu
(Shift) F2 key	Change color from total 16 colors. F2 to select color forward, (Shift) F2 to select color backward
F3 key	Reserved
F4 key	Reserved
F5 key	Restore the previous CMOS value from CMOS, only for Option Page Setup Menu
F6 key	Load the default CMOS value from BIOS default table, only for Option Page Setup Menu
F7 key	Load the Setup default, only for Option Page Setup Menu
F8 key	Reserved
F9 key	Reserved
F10 key	Save all the CMOS changes, only for Main Menu

4.3 Getting Help

- **Main Menu**

The online description of the highlighted setup function is displayed at the bottom of the screen.

- **Status Page Setup Menu/Option Page Setup Menu**

Press <F1> to pop out a small Help window that provides the description of using appropriate keys and possible selections for highlighted items. Press <F1> or <Esc> to exit the Help Window.

4.4 The Main Menu

Once you enter the Award BIOS CMOS Setup Utility, the Main Menu appears on the screen. In the Main Menu, there are several Setup functions and a couple of Exit options for your selection. Use arrow keys to select the Setup Page you intend to configure then press <Enter> to accept or enter its sub-menu.

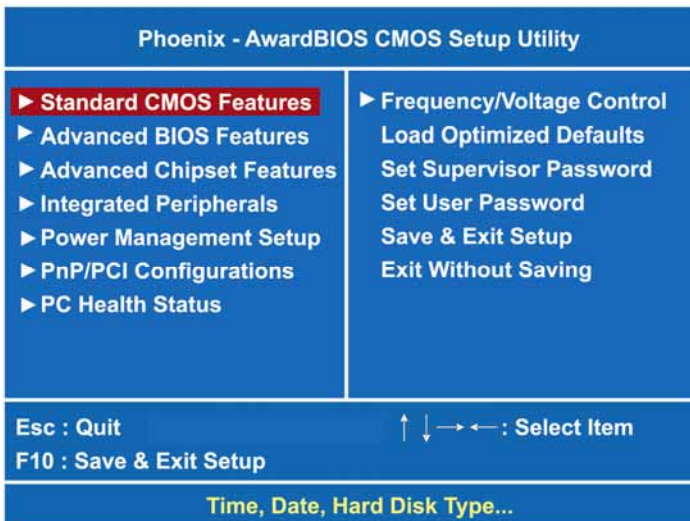

NOTE If your computer can not boot after making and saving system changes with Setup, the Award BIOS will reset your system to the CMOS default settings via its built-in override feature.

4.5 Standard CMOS Setup Menu

The Standard CMOS Setup Menu displays basic information about your system. Use arrow keys to highlight each item, and use <PgUp> or <PgDn> key to select the value you want in each item.

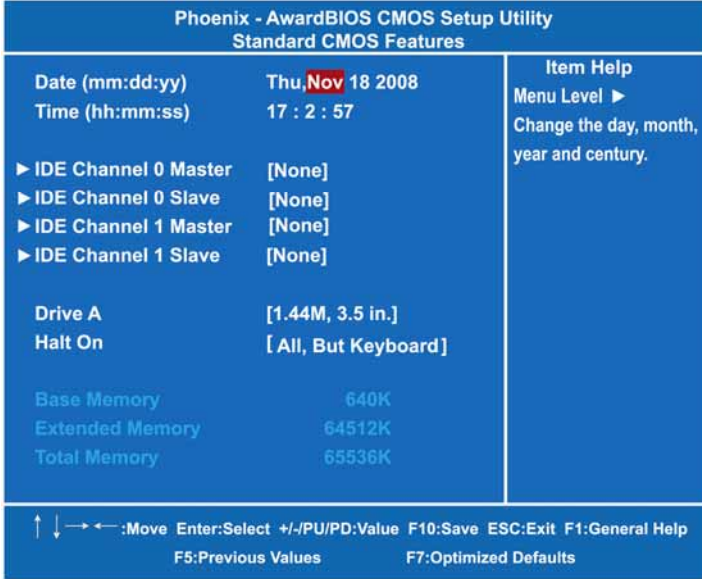

- **Date**

The date format is <day>, <date> <month> <year>. Press <F3> to show the calendar.

day	It is determined by the BIOS and read only, from Sunday to Saturday.
date	It can be keyed with the numerical/ function key, from 1 to 31.
month	It is from January to December.
year	It shows the current year of BIOS.

- **Time**

This item shows current time of your system with the format <hour> <minute> <second>. The time is calculated based on the 24-hour military-time clock. For example, 1 p.m. is 13:00:00.

- **IDE Channel 0/1 Master/Slave**

These items identify the types of each IDE channel installed in the computer. There are 45 predefined types (Type 1 to Type 45) and 2 user's definable types (Type User) for Enhanced IDE BIOS. Press <PgUp>/<+> or <PgDn>/<-> to select a numbered hard disk type, or directly type the number and press <Enter>. Please be noted your drive's specifications must match the drive table. The hard disk will not work properly if you enter improper information. If your hard disk drive type does not match or is not listed, you can use Type User to manually define your own drive type. If selecting Type User, you will be asked to enter related information in the following items. Directly key in the information and press <Enter>. This information should be provided in the documentation from your hard disk vendor or the system manufacturer.

If the HDD interface controller supports ESDI, select "Type 1".

If the HDD interface controller supports SCSI, select "None".

If the HDD interface controller supports CD-ROM, select "None".

CYLS.	number of cylinders	LANDZONE	landing zone
HEADS	number of heads	SECTORS	number of sectors
PRECOMP	write precom	MODE	HDD access mode

If there is no hard disk drive installed, select NONE and press <Enter>.

- **Drive A**

Select the type of floppy drive installed in your system, and the default is "None".

- **Halt On**

This item determines whether the system will halt or not, if an error is detected while powering up.

No errors	The system booting will halt on any errors
All errors	Whenever BIOS detects a non-fatal error, the
All, But	The system booting will not stop for a keyboard
All, But	The system booting will not stop for a disk
All, But	The system booting will not stop for a keyboard

Press <Esc> to return to the Main Menu page.

4.6 Advanced BIOS Features

This section allows you to configure and improve your system, to set up some system features according to your preference.

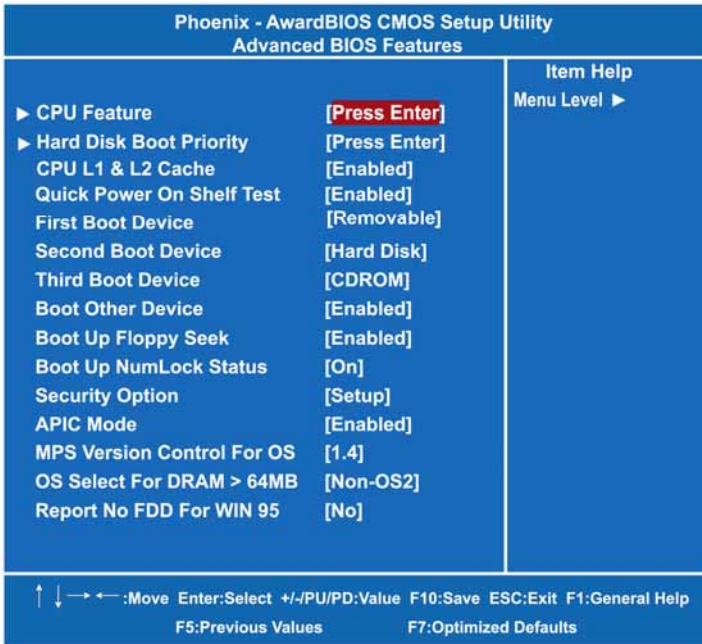

● CPU Feature

Scroll to this item and press <Enter> to view the CPU Feature sub menu.

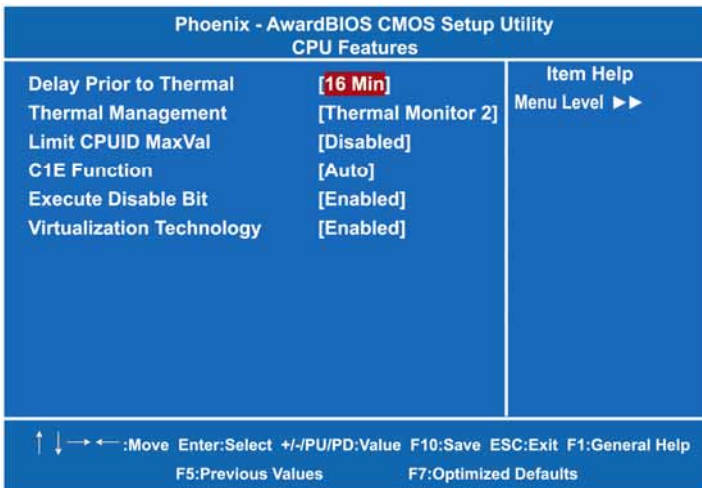

➤ **Delay prior to Thermal**

This field is used to select the time that would force the CPU to a 50% duty cycle when it exceeds its maximum operating temperature therefore protecting the CPU and the system board from overheating to ensure a safe computing environment.

➤ **Thermal Management**

Thermal Monitor 1 On-die throttling

Thermal Monitor 2 Ratio and VID transition

➤ **Limit CPUID MaxVal**

The CPUID instruction if some newer CPUs will return a value greater than 3. The default is "*Disabled*", because this problem does not exist in the Windows series operating systems. If you are using an operating system other than Windows, this problem may occur. To avoid this problem, you can enable this field to limit the return value to 3 or lesser than 3.

➤ **C1E Function**

The Intel® CPU Enhanced Halt (C1E) function is a CPU power-saving function in system halt state. When enabled, the CPU core frequency and voltage will be reduced during system halt state to decrease power consumption.

➤ **Execute Disable Bit**

Use this item to enable the hardware-based security feature that reduces exposure to viruses and malicious-code attacks.

➤ **Virtualization Technology**

When this feature is enabled, the computer system can operate as multiple "virtual" systems.

Press <Esc> to return to the Advanced BIOS Features page.

● **Hard Disk Boot Priority**

Scroll to this item and press <Enter> to view the sub menu to decide the disk boot priority.

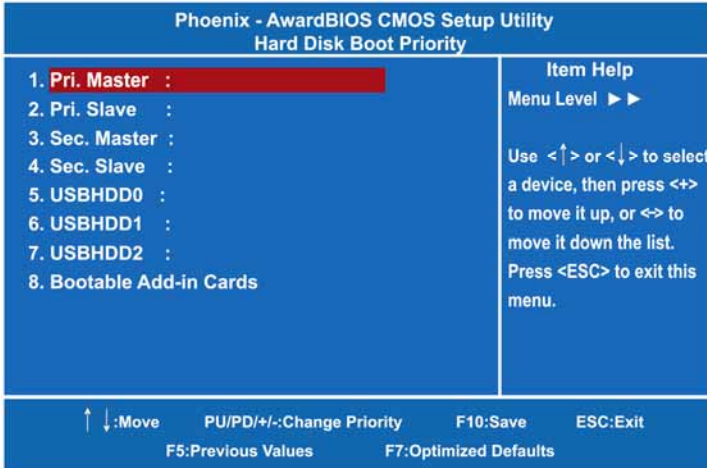

Press <Esc> to return to the Advanced BIOS Features page.

● **CPU L1 & L2 Cache**

These two options speed up memory access. However, it depends on the CPU/chipset design. The default setting is “Enabled”. CPUs without built-in internal cache will not provide the “CPU Internal Cache” item on the menu.

Enabled	Enable cache
Disabled	Disable cache

● **Quick Power On Self Test**

This option speeds up Power on Self Test (POST) after you turn on the system power. If set as Enabled, BIOS will shorten or skip some check items during POST. The default setting is “Enabled”.

Enabled	Enable Quick POST
Disabled	Normal POST

● First/Second/Third Boot Device

These items let you select the 1st, 2nd, and 3rd devices that the system will search for during its boot-up sequence. There is a wide range of options for your selection.

● Boot Other Device

This item allows the user to enable/disable the boot device not listed on the First/Second/Third boot devices option above. The default setting is "Enabled".

● Boot Up Floppy Seek

During POST, BIOS will determine the floppy disk drive type, 40 or 80 tracks. The 360Kb type is 40 tracks while 720Kb, 1.2MB and 1.44MB are all 80 tracks. The default value is "Enabled".

Enabled	BIOS searches for floppy disk drive to determine if it is 40 or 80 tracks. Please be noted BIOS can not differentiate 720K, 1.2M or 1.44M drive types as they all are 80 tracks.
Disabled	BIOS will not search for the type of floppy disk drive by track number. There will be no warning message displayed if the installed drive is 360K.

● Boot Up NumLock Status

Set the the Num Lock status when the system is powered on.

The default value is "On".

● Security Option

This item allows you to limit access to the system and Setup, or just to Setup. The default value is "Setup".

System	If a wrong password is entered at the prompt, the system will not boot, the access to Setup will be denied, either.
Setup	If a wrong password is entered at the prompt, the system will boot, but the access to Setup will be denied.

NOTE *To disable the security, select **PASSWORD SETTING** at Main Menu and then you will be asked to enter a password. Do not type anything, just press <Enter> and it will disable the security. Once the security is disabled, the system will boot and you can enter Setup freely.*

● **APIC Mode**

Use this item to enable or disable APIC (Advanced Programmable Interrupt Controller) mode that provides symmetric multi-processing (SMP) for systems.

● **MPS Version Control For OS**

This item specifies the version of the Multiprocessor Specification (MPS). Version 1.4 has extended configuration tables to improve support for multiple PCI bus configurations and provide future expandability.

● **OS Select for DRAM >64MB**

This item allows you to access the memory over 64MB in OS/2.

● **Report No FDD For WIN 95**

Select Yes to release an IRQ when the system doesn't have any floppy drive, for compatibility with Windows 95 logo certification. In the Integrated Peripherals screen, select Disabled for the Onboard FDC Controller field.

Press <Esc> to return to the Main Menu page.

4.7 Advanced Chipset Features

This section contains completely optimized chipset's features on the board that you are strongly recommended to leave all items on this page at their default values unless you are very familiar with the technical specifications of your system hardware.

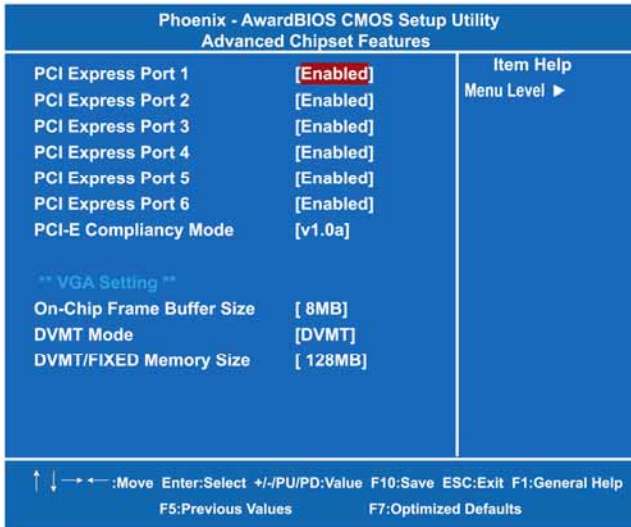

● PCI-E Compliancy Mode

This item allows users to set the version of the PCI Express based on the specification by which the motherboard has to comply.

*** VGA Setting ***

● On-Chip Frame Buffer Size

Use this item to set the VGA frame buffer size.

● DVMT Mode

DVMT (Dynamic Video Memory Technology) helps you select the video mode.

● DVMT/Fixed Memory Size

DVMT (Dynamic Video Memory Technology) allows you to select a maximum size of dynamic amount usage of the video memory. The system would configure the video memory dependent on your application.

Press <Esc> to return to the Main Menu page.

4.8 Integrated Peripherals

This section allows you to configure your OnChip IDE Device, Onboard Device and SuperIO Device.

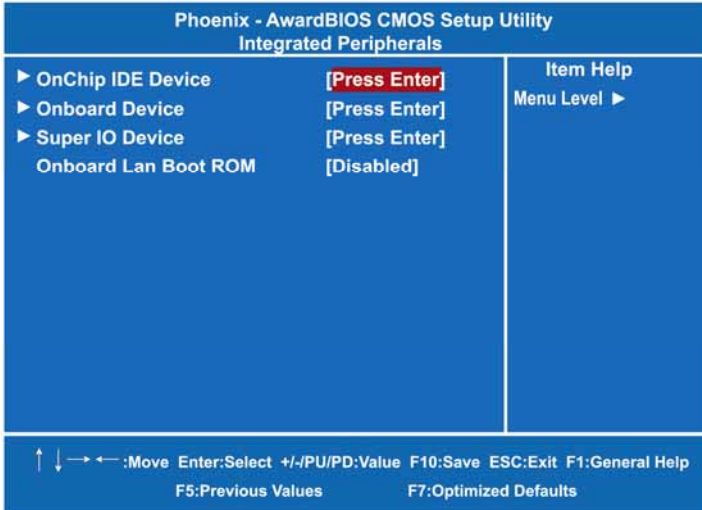

● OnChip IDE Device

Scroll to this item and press <Enter> to view the sub menu OnChip IDE Device.

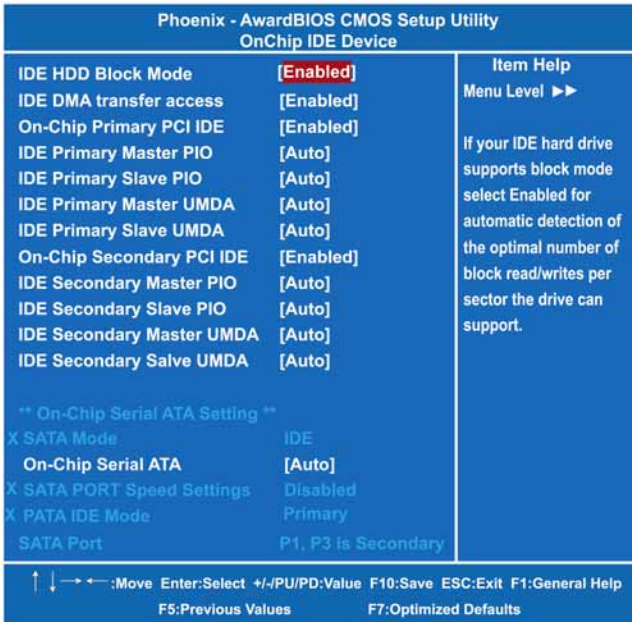

➤ **IDE HDD Block Mode**

Block mode is also called block transfer, multiple commands, or multiple sector read/write. If your IDE hard drive supports block mode (most new drives do), select Enabled for automatic detection of the optimal number of block read/writes per sector the drive can support.

➤ **IDE DMA transfer access**

Automatic data transfer between system memory and IDE device with minimum CPU intervention. This improves data throughput and frees CPU to perform other tasks.

➤ **On-Chip Primary/Secondary PCI IDE**

The integrated peripheral controller contains an IDE interface with support for two IDE channels. Select Enabled to activate each channel separately. The default value is "Enabled".

NOTE *Choosing Disabled for these options will automatically remove the IDE Primary Master/ Slave PIO and/or IDE Secondary Master/Slave PIO items on the menu.*

➤ **IDE Primary/Secondary Master/Slave PIO**

The four IDE PIO (Programmed Input/Output) fields let you set a PIO mode (0-4) for each of the four IDE devices that the onboard IDE interface supports. Modes 0 to 4 provide successively increased performance. In Auto mode, the system automatically determines the best mode for each device.

➤ **IDE Primary/Secondary Master/Slave UDMA**

Select the mode of operation for the IDE drive. Ultra DMA-33/66/100/133 implementation is possible only if your IDE hard drive supports it and the operating environment includes a DMA driver. If the hard drive and system software both support Ultra DMA-33/66/100/133, select Auto to enable UDMA mode by BIOS.

***** On-Chip Serial ATA Setting *****

➤ **SATA Mode**

There are these options for you to set up SATA mode: IDE or RAID.

➤ **On-Chip Serial ATA**

Use this item to enable or disable the built-in on-chip serial ATA.

➤ **SATA PORT Speed Settings**

Use this item to select SATA I or SATA II device support forcedly.

➤ **PATA IDE Mode**

Use this item to set the PATA IDE mode. When the PATA IDE mode is set for Primary, P1 and P3 are Secondary; on the other hand, when set for Secondary, P0 and P2 are Primary.

➤ **SATA Port**

When the "PATA IDE Mode" is Primary, SATA Port will be " P1, P3 is Secondary" that means SATA 2 and SATA 4 are Secondary; when Secondary, it will be "P0, P2 is Primary ", SATA 1 and SATA 3 are Primary.

Press <Esc> to return to the Integrated Peripherals page.

● Onboard Device

Scroll to this item and press <Enter> to view the sub menu Onboard Device.

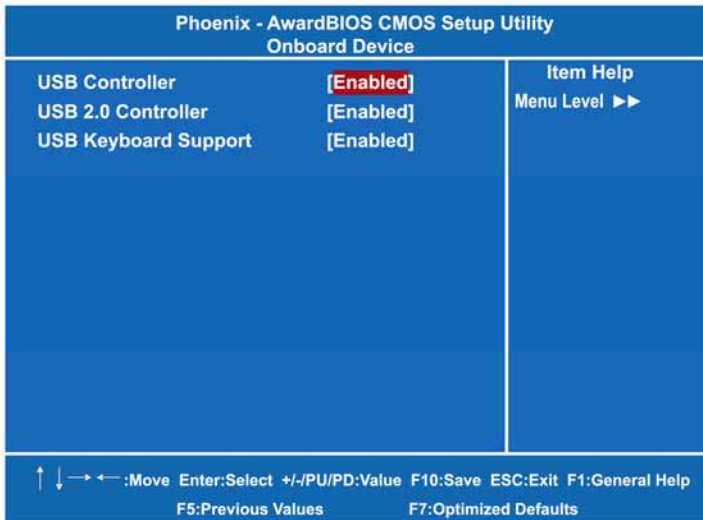

➤ USB Controller

Enable this item if you are using the USB in the system. You should disable this item if a higher-level controller is added.

➤ USB 2.0 Controller

Enable this item if you are using the EHCI (USB2.0) controller in the system.

➤ USB Keyboard Support

Enable this item if the system has a Universal Serial Bus (USB) controller, and you have a USB keyboard.

Press <Esc> to return to the Integrated Peripherals page.

● Super IO Device

Scroll to this item and press <Enter> to view the sub menu Super IO Device.

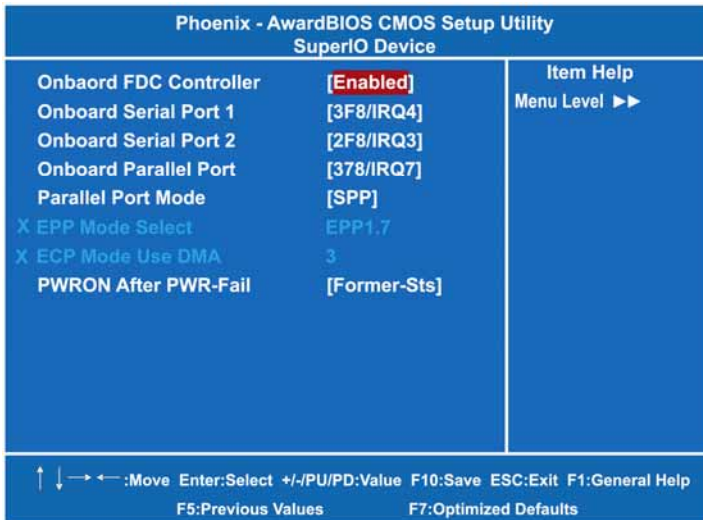

➤ Onboard FDC Controller

Select Enabled, if your system has a floppy disk controller (FDC) installed on the system board and you want to use it. If you install and-in FDC or the system has no floppy drive, select Disabled in this field. Options: "Enabled" and "Disabled".

➤ Onboard Serial Port 1/2

Select an address and corresponding interrupt for the serial port.

➤ Parallel Port Mode

Select an operating mode for the onboard parallel (printer) port. Select Normal unless your hardware and software require another mode in this field. There are several options for your selection, "EPP1.9", "ECP", "SPP", "ECPEPP1.7", "EPP1.7", etc.

➤ EPP Mode Select

Select EPP port type 1.7 or 1.9.

➤ ECP Mode Use DMA

Select a DMA channel for the parallel port while using the ECP mode.

➤ **PWRON After PWR-Fail**

This item enables your computer to automatically restart or return to its operating status.

Press <Esc> to return to the Integrated Peripherals page.

● **Onboard Lan Boot ROM**

Use this item to enable or disable the Boot ROM function of the onboard LAN chip when the system boots up.

4.9 Power Management Setup

The Power Management Setup allows you to save energy of your system effectively. It will shut down the hard disk and turn OFF video display after a period of inactivity.

Phoenix - AwardBIOS CMOS Setup Utility		Item Help
Power Management Setup		Menu Level ►
ACPI Function	Enabled	
ACPI Suspend Type	[S1(POS)]	
Power Management	[User Define]	
Video Off Method	[dpms]	
Video Off In Suspend	[Yes]	
Suspend Type	[Stop Grant]	
Suspend Mode	[Disabled]	
HDD Power Down	[Disabled]	
Soft-Off by PWR-BTTN	[Instant-Off]	
PowerOn by Ring	[Enabled]	
Resume by Alarm	[Disabled]	
X Date <of Month> Alarm	0	
X Time <hh:mm:ss> Alarm	0 : 0 : 0	
Primary IDE 0	[Disabled]	
Primary IDE 1	[Disabled]	
Secondary IDE 0	[Disabled]	
Secondary IDE 1	[Disabled]	
FDD, COM, LPT Port	[Disabled]	

↑ ↓ ← → : Move Enter: Select +/-/PU/PD: Value F10: Save ESC: Exit F1: General Help
F5: Previous Values F7: Optimized Defaults

● ACPI Function

This item allows you to enable/disable the Advanced Configuration and Power Management (ACPI). The function is always “Enabled”.

ACPI Suspend Type

This item specifies the power saving modes for ACPI function. If your operating system supports ACPI, such as Windows 98SE, Windows ME and Windows 2000, you can choose to enter the Standby mode in S1 (POS) or S3 (STR) fashion through the setting of this field. Options are:

[S1(POS)] The S1 sleep mode is a low power state. In this state, no system context is lost (CPU or chipset) and hardware maintains all system context.

[S3(STR)] The S3 sleep mode is a lower power state where the information of

system configuration and open applications/files is saved to main memory that remains

powered while most other hardware components turn off to save energy. The information stored in memory will be used to restore the system when a “wake up” event occurs.

● **Power Management**

This option allows you to select the type (or degree) of power saving for Doze, Standby, and Suspend modes. The table below describes each power management mode:

Max Saving	It is maximum power savings, only available for SL CPUs. The inactivity period is 1 minute in each mode.
User Define	It sets each mode. Select time-out periods in the PM Timers section.
Min Saving	It is minimum power savings. The inactivity period is 1 hour in each mode (except the hard drive).

● **Video Off Method**

This setting determines the manner in which the monitor is blanked.

V/H SYNC+Blank	Turns OFF vertical and horizontal synchronization ports and writes blanks to the video buffer
DPMS	Select this option if your monitor supports the Display Power Management Signaling (DPMS) standard of the Video Electronics Standards Association (VESA). Use the software supplied for your video subsystem to select video power management values.
Blank Screen	System only writes blanks to the video buffer.

● **Video Off In Suspend**

This item defines if the video is powered down when the system is put into suspend mode.

● **Suspend Type**

If this item is set to the default Stop Grant, the CPU will go into Idle Mode during power saving mode.

● **Suspend Mode**

After the selected period of system inactivity (1 minute to 1 hour), all devices except the CPU shut off. The default value is "Disabled".

Disabled	System will never enter SUSPEND mode
1/2/4/6/8/10 /20/30/40 Min/1 Hr	Defines the continuous idle time before the system entering SUSPEND mode. If any item defined in (J) is enabled & active, SUSPEND timer will be reloaded

● **HDD Power Down**

If HDD activity is not detected for the length of time specified in this field, the hard disk drive will be powered down while all other devices remain active.

● **Soft-Off by PWR-BTTN**

This option only works with systems using an ATX power supply. It also allows the user to define which type of soft power OFF sequence the system will follow. The default value is "Instant-Off".

Instant-Off	This option follows the conventional manner systems perform when power is turned OFF. Instant-Off is a soft power OFF sequence requiring only the switching of the power supply button to OFF
Delay 4 Sec.	Upon turning OFF system from the power switch, this option will delay the complete system power OFF sequence by approximately 4 seconds. Within this delay period, system will

temporarily enter into Suspend Mode enabling you to restart the system at once.

● **Power On by Ring**

This option allows the system to resume or wake up upon detecting any ring signals coming from an installed modem. The default value is "Enabled".

● **Resume by Alarm**

If enable this item, the system can automatically resume after a fixed time in accordance with the system's RTC (realtime clock).

● **Primary/Secondary IDE 0/1**

Use this item to configure the IDE devices monitored by the system.

● **FDD, COM, LPT Port**

Use this item to configure the FDD, COM and LPT ports monitored by the system.

Press <Esc> to return to the Main Menu page.

4.10 PnP/PCI Configuration Setup

This section describes the configuration of PCI (Personal Computer Interconnect) bus system, which allows I/O devices to operate at speeds close to the CPU speed while communicating with other important components. This section covers very technical items that only experienced users could change default settings.

Phoenix - AwardBIOS CMOS Setup Utility PnP/PCI Configurations		
PNP OS Installed	[No]	Item Help Menu Level ► Select Yes if you are using a Plug and Play capable operating system Select No if you need the BIOS to configure non-boot devices
Init Display First	[Onboard]	
Reset Configuration Data	[Disabled]	
Resources Controlled By	[Auto(ESCD)]	
X IRQ Resources	Press Enter	
X DMA Resources	Press Enter	
PCI/VGA Palette Snoop	[Disabled]	
** PCI Express relative items **		
Maximum Payload Size	[4096]	
↑ ↓ ← → :Move Enter:Select +/-/PU/PD:Value F10:Save ESC:Exit F1:General Help F5:Previous Values F7:Optimized Defaults		

● PNP OS Installed

Select Yes if the system operating environment is Plug-and-Play aware (e.g., Windows 95). The default value is "No".

● Init Display First

This item allows you to decide whether PCI Slot or Onboard to be the first primary display card.

● Reset Configuration Data

Normally, you leave this item Disabled. Select Enabled to reset Extended System Configuration Data (ESCD) when you exit Setup or if installing a new add-on cause the system reconfiguration a serious conflict that the operating system can not boot. Options: Enabled, Disabled.

● Resources Controlled By

The Award Plug and Play BIOS can automatically configure all boot and Plug and Play-compatible devices. If you select Auto, all interrupt request (IRQ), DMA assignment, and Used DMA fields disappear, as the BIOS automatically assigns them. The default value is "Auto (ESCD)".

● IRQ Resources

When resources are controlled manually, assign each system interrupt to one of the following types in accordance with the type of devices using the interrupt:

1. Legacy ISA Devices compliant with the original PC AT bus specification, requiring a specific interrupt (such as IRQ4 for serial port 1).
2. PCI/ISA PnP Devices compliant with the Plug and Play standard, whether designed for PCI or ISA bus architecture.

The default value is *"PCI/ISA PnP"*.

● DMA Resources

When resources are controlled manually, assign each system DMA channel as one of the following types, depending on the type of device using the interrupt:

Legacy ISA Devices compliant with the original PC AT bus specification, requiring a specific DMA channel.

PCI/ISA PnP Devices compliant with the Plug and Play standard, whether designed for PCI or ISA bus architecture.

The default value is *"PCI/ISA PnP"*.

● PCI/VGA Palette Snoop

Some non-standard VGA display cards may not show colors properly. This item allows you to set whether MPEG ISA/VESA VGA Cards can work with PCI/VGA or not. When enabled, a PCI/VGA can work with a MPEG ISA/VESA VGA card; when disabled, a PCI/VGA cannot work with a MPEG ISA/VESA Card.

**** PCI Express relative items ****

● Maximum Payload Size

When using DDR SDRAM and Buffer size selection, another consideration in designing a payload memory is the size of the buffer for data storage. Maximum Payload Size defines the maximum TLP (Transaction Layer Packet) data payload size for the device.

Press <Esc> to return to the Main Menu page.

4.11 PC Health Status

This section supports hardware monitoring that lets you monitor those parameters for critical voltages, temperatures and fan speed of the board.

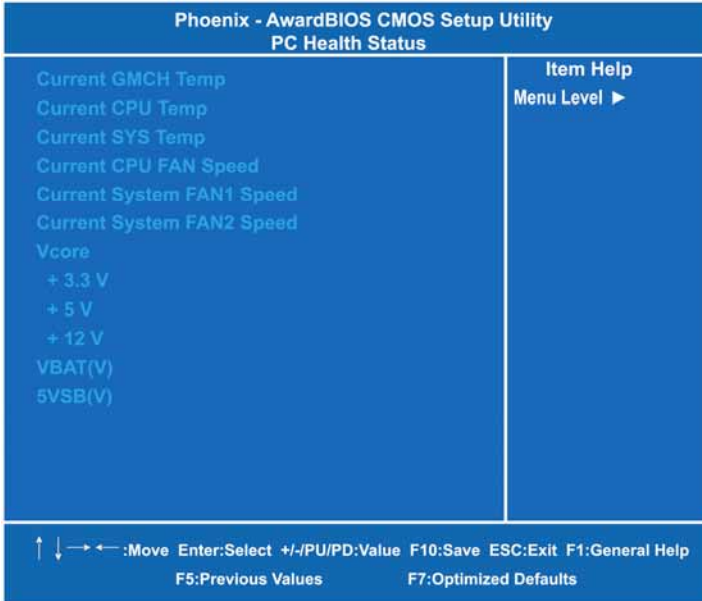

● Current GMCH Temperature

The current GMCH temperature will be automatically detected by the system.

● Current CPU Temperature

These read-only fields show the functions of the hardware thermal sensor by CPU thermal diode that monitors the chip blocks to ensure a stable system.

● Current SYS Temperature

Show you the current system temperature.

● Current CPU FAN Speed

These optional and read-only items show current speeds in RPM (Revolution Per Minute) for the CPU fan and chassis fan as monitored by the hardware monitoring IC.

● Current SYSTEM FAN1 Speed

Show you the current system fan1 speed.

- **Current SYSTEM FAN2 Speed**

Show you the current system fan2 speed.

- **Vcore +3.3V/+5V/+12V/VBAT(V)/5VSB**

It shows the voltage of +3.3V/+5V/+12V.

Press <Esc> to return to the Main Menu page.

4.12 Frequency/Voltage Control

This section is to control the CPU frequency and Supply Voltage, DIMM OverVoltage and AGP voltage.

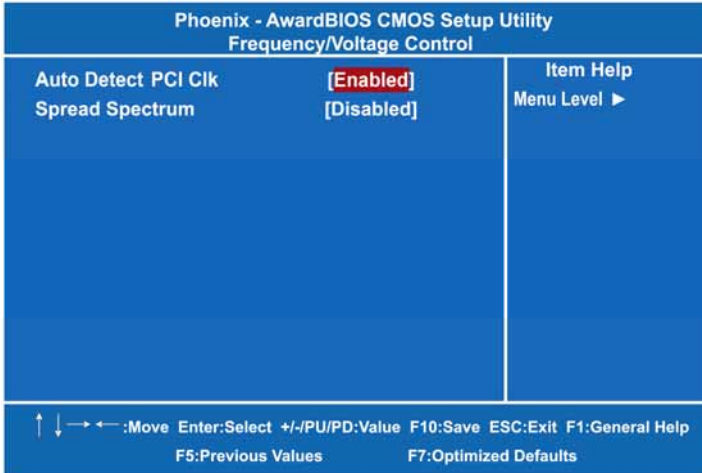

● Auto Detect PCI Clk

The enabled item can automatically disable the clock source for a PCI slot without a module, to reduce EMI (ElectroMagnetic Interference).

● Spread Spectrum

If spread spectrum is enabled, EMI (ElectroMagnetic Interference) generated by the system can be significantly reduced.

Press <Esc> to return to the Main Menu page.

4.13 Load Optimized Defaults

This option allows you to load your system configuration with default values.

These default settings are optimized to enable high performance features.

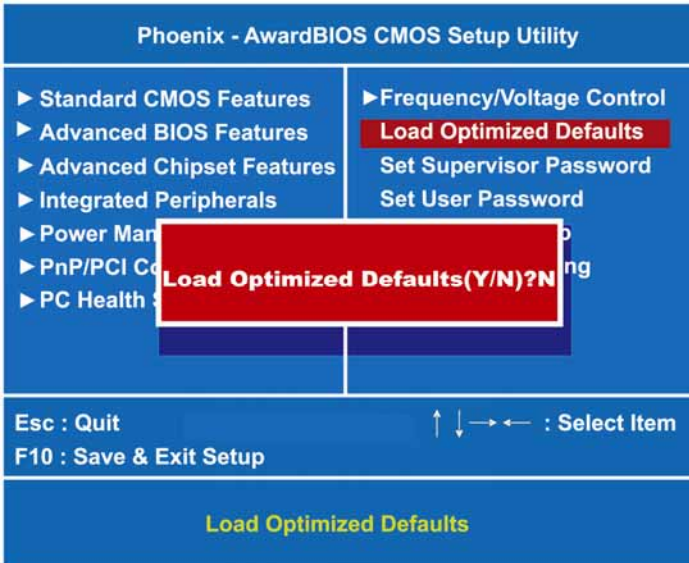

To load CMOS SRAM with SETUP default values, please enter "Y". If not, please enter "N".

4.14 Set Supervisor/User Password

You can set a supervisor or user password, or both of them. The differences between them are:

1. **Supervisor password:** You can enter and change the options on the setup menu.
2. **User password:** You can just enter, but have no right to change the options on the setup menu.

When you select this function, the following message will appear at the center of the screen to assist you in creating a password.

ENTER PASSWORD

Type a maximum eight-character password, and press <Enter>. This typed password will clear previously entered password from the CMOS memory. You will be asked to confirm this password. Type this password again and press <Enter>. You may also press <Esc> to abort this selection and not enter a password. To disable the password, just press <Enter> when you are prompted to enter a password. A message will confirm the password is getting disabled. Once the password is disabled, the system will boot and you can enter Setup freely.

PASSWORD DISABLED

When a password is enabled, you have to type it every time you enter the Setup. It prevents any unauthorized persons from changing your system configuration. Additionally, when a password is enabled, you can also require the BIOS to request a password every time the system reboots. This would prevent unauthorized use of your computer.

You decide when the password is required for the BIOS Features Setup Menu and its Security option. If the Security option is set to "System", the password is required during booting up and entry into the Setup; if it is set as "Setup", a prompt will only appear before entering the Setup.

4.15 Save & Exit Setup

This section allows you to determine whether or not to accept your modifications.

Type "Y" to quit the setup utility and save all changes into the CMOS memory.

Type "N" to bring you back to the Setup utility.

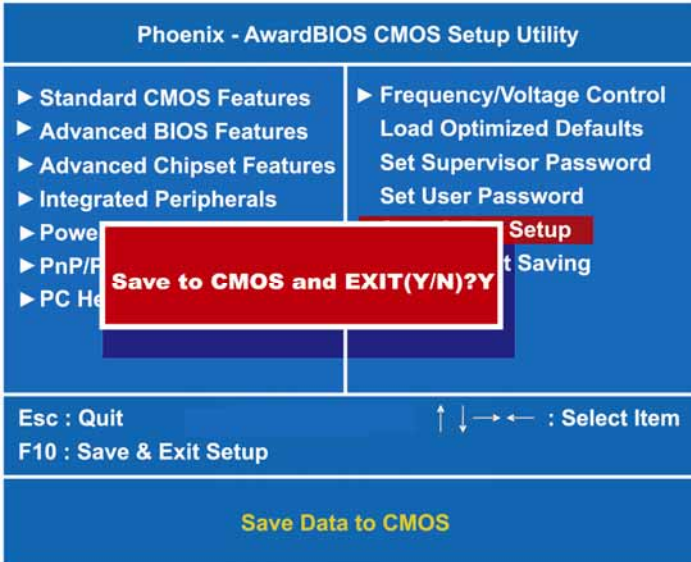

4.16 Exit Without Saving

Select this option to exit the Setup utility without saving changes you have made in this session. Type “Y”, and it will quit the Setup utility without saving your modifications. Type “N” to return to the Setup utility.

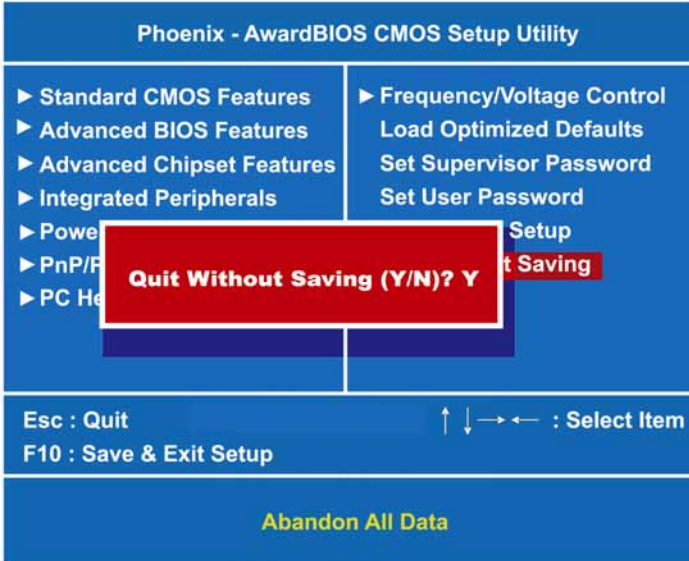

**The Global Choice for Premium Industrial
Computer Products**

www.aicsys.com