

## FITTING AND CONNECTION INSTRUCTIONS

The **ORION** consists of a die-cast aluminium casing containing the gearbox, electric motor and adjustable friction clutch. The gears are immersed in oil. The anti-crush friction clutch allows the operator torque to be adjusted to a safe level. The operator is fitted with a motor rotation sensor. When the clutch slips the rotation sensor is activated, sending a signal to the sophisticated electronic control unit stopping and inverting the motor direction. The gate travel limit switch is an inductive type. Electronic braking assures repeated gate stopping accuracy. In case of a power failure the operator can be released using a special key and the gate manually operated until power is restored. The Orion can be signalled to partially open a gate so to provide pedestrian access only.

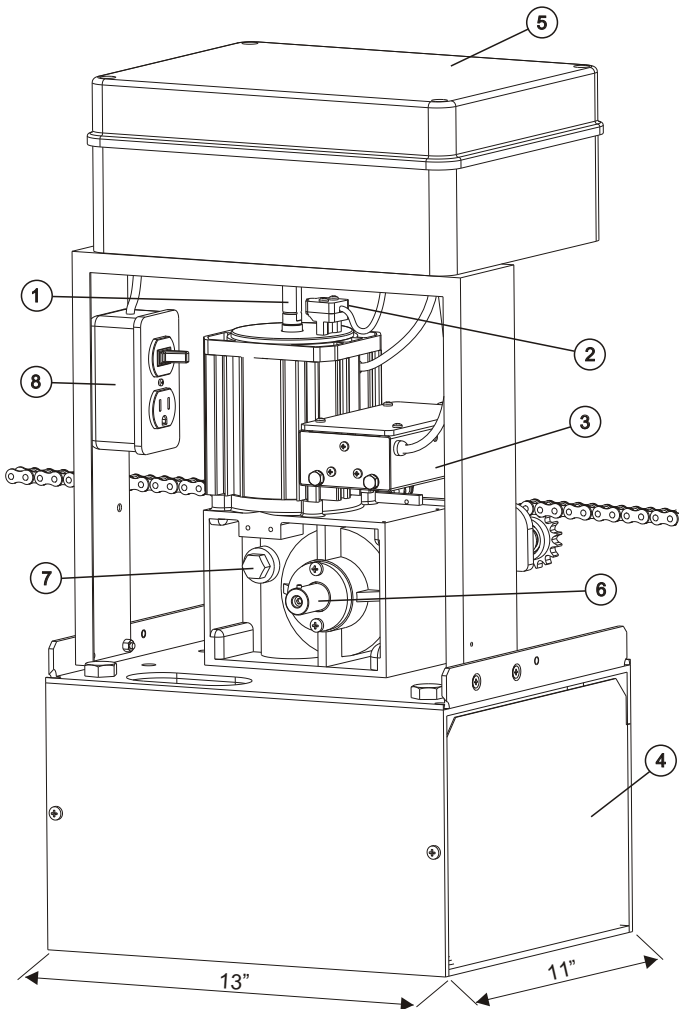

- |                                     |                           |
|-------------------------------------|---------------------------|
| 1 Adjusting screw mechanical clutch | 5 Electronic control unit |
| 2 Magnetic encoder                  | 6 Release                 |
| 3 Limit switch                      | 7 Oil level indicator     |
| 4 Foundation plate                  | 8 Main switch             |

### TECHNICAL DATA

Power supply	115 V (±5%) 50/60 Hz
Power	300 W
Absorbed current	3,1 A
Thrust force	27 Nm
Capacitor	80uF
Gate speed (pinion Z26)	12,6 In/sec
Use rate	50 %
Housing protection	IP 55

### Gate arrangement

The first thing to check is that the gate is in good running order as follows:

- The gate is rigid and straight and runs smoothly throughout its travel.
- that the inferior sliding guide-rail is perfectly straight and horizontal to avoid a derailment of the gate (fig. 1); furthermore it must be free of irregularities and foreign bodies which could obstruct the normal run of the gate (fig. 2 and 3).
- that the upper guides are not fixed (fig. 4) but furnished with rollers which allow the sliding of the gate without difficulties (fig. 5 and 6).
- that the distance between the end of the gate (in maximum opening position) and the eventual wall must be at least of 5 inches (fig. 7).
- The lower support wheels have sealed bearings or grease points.
- The top guide must be manufactured and installed so that the gate is perfectly upright.
- Physical gate stops must be fitted to prevent the gate coming out of its guides and track.

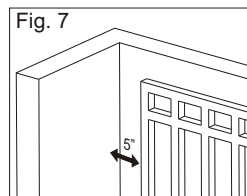
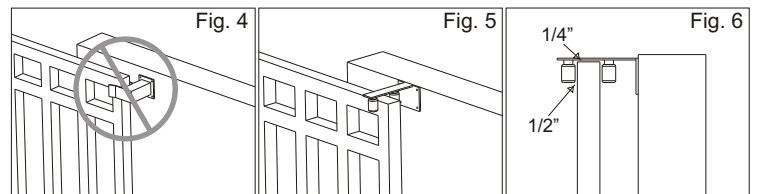
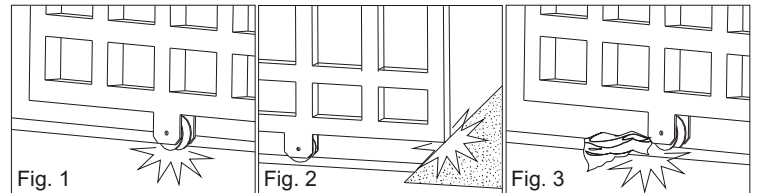

**Important:** Install the warning signs which informs the pedestrians about the danger they run when passing or resting in the environment of the gate.

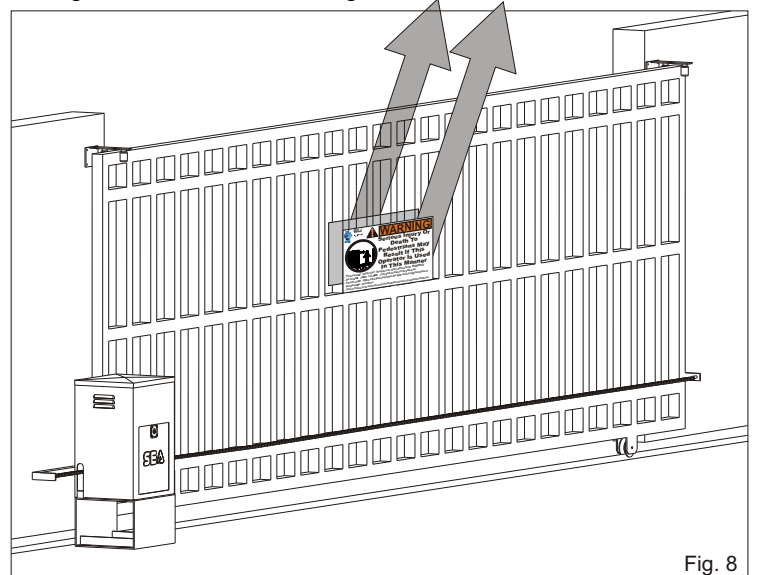

Fig. 8

## FITTING AND CONNECTION INSTRUCTIONS

### Mounting plate installation

To install the mounting plate it is necessary to:

1) Have a mounting plate manufactured to the dimensions shown in Fig. 1. The plate will require to have concrete holding ties welded to the base.

N.B. It is best if the gate structure allows the plate to be raised up from the finished level by 2". This will stop water gathering around the operator.

2) When you are concreting in the plate install any necessary cable ducts (1" dia. minimum) and cables in through the base plate. Cable ducts should have sweep bends not elbow ones.

3) When concreting in the plate check that the plate is perfectly levelled.

4) The chain must be at a minimum distance of 3" from the gate.

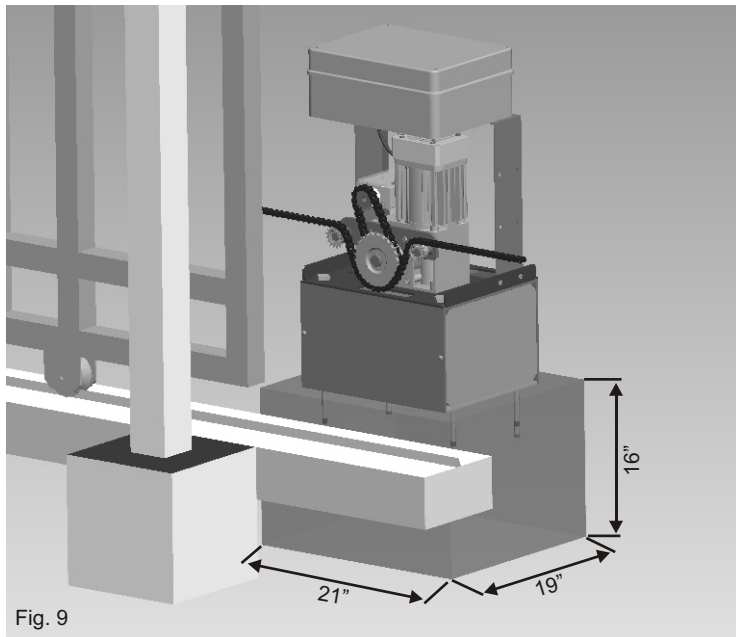

### RELEASE

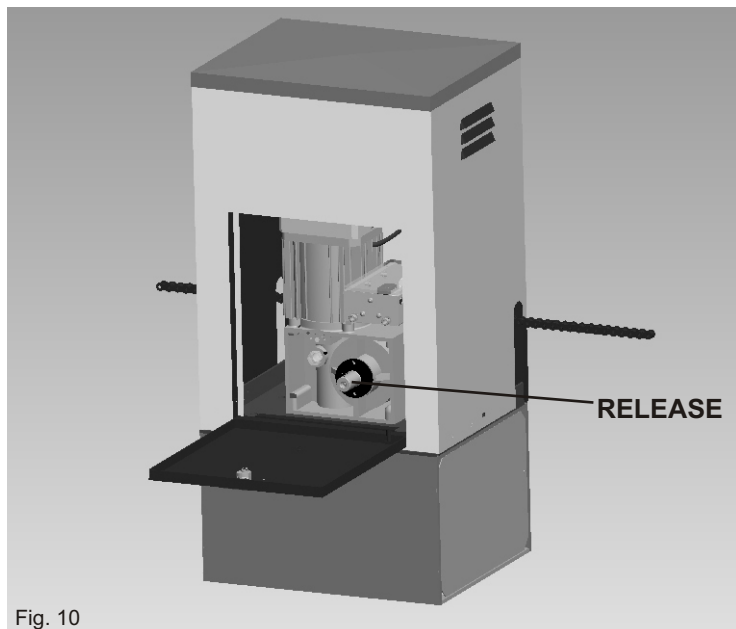

### Release device

To release the gate:

- On the side of the operator opposite to the pinion insert the hexagon "T" key (Fig. 11) and without forcing turn the key clockwise until it stops (Fig. 12);
- manually open and close the gate.

To reconnect:

- Insert the hexagon "T" key (Fig. 11) and without forcing turn anticlockwise until it stops (Fig. 12);
- slowly manually slide the gate until it reconnects the drive;
- do not attempt to use the operator electrically before reconnecting the drive.

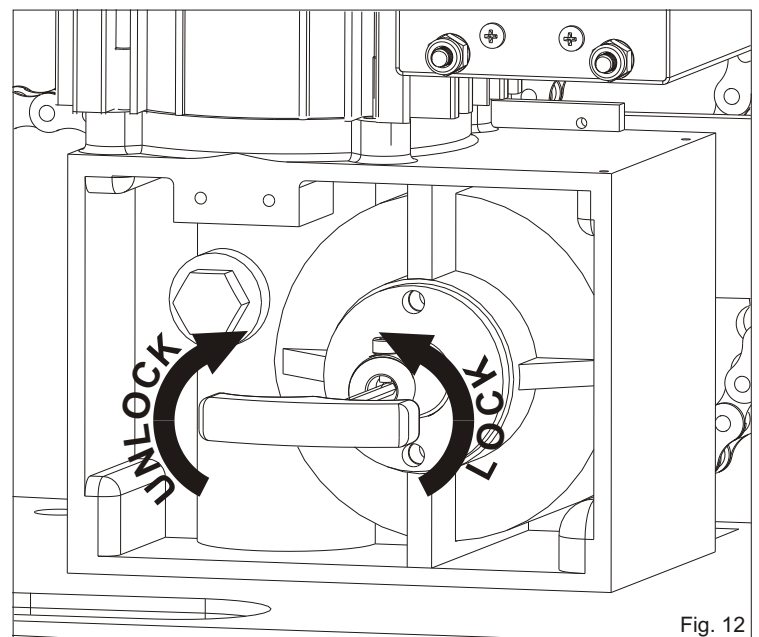
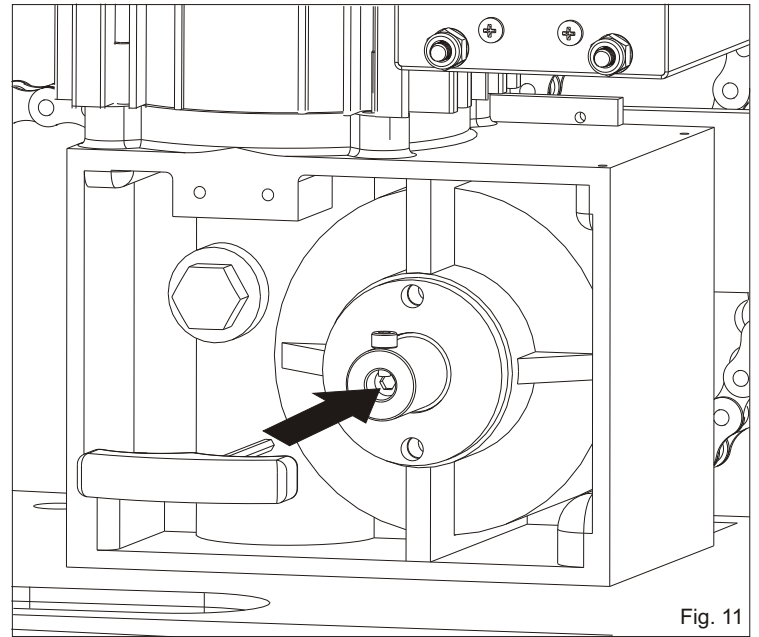

## FITTING AND CONNECTION INSTRUCTIONS

### LIMIT SWITCH ADJUSTING:

Before acting on the limit switch, make sure that during the assembling of the motor reducer complete of chain at the gate, the limit switch cursor must be in the central position of its run (Fig. 13) and the gate must be in the middle of its opening.

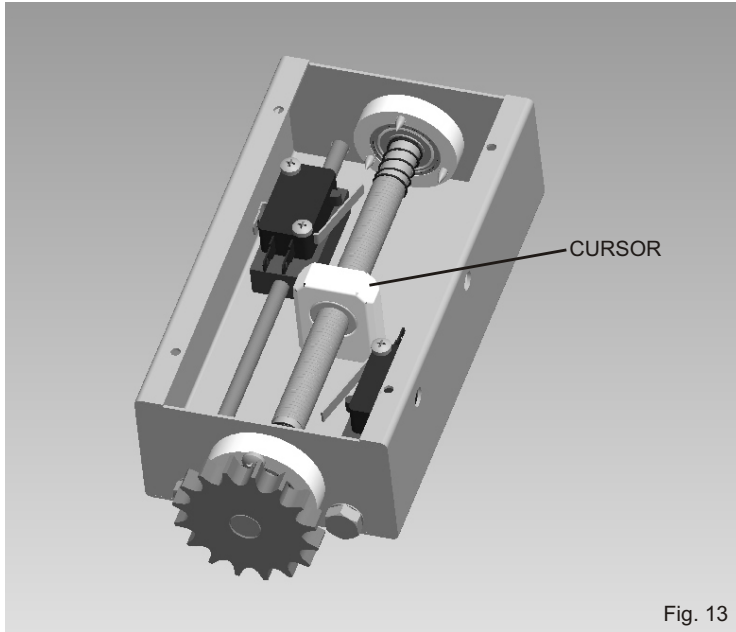

To install and adjust the limit switches in opening, see the following instructions:

- release the motor reducer
- bring the gate to the complete opening
- act on the adjusting screw so that the microswitch can activate the contact with the cursor (Fig. 14)

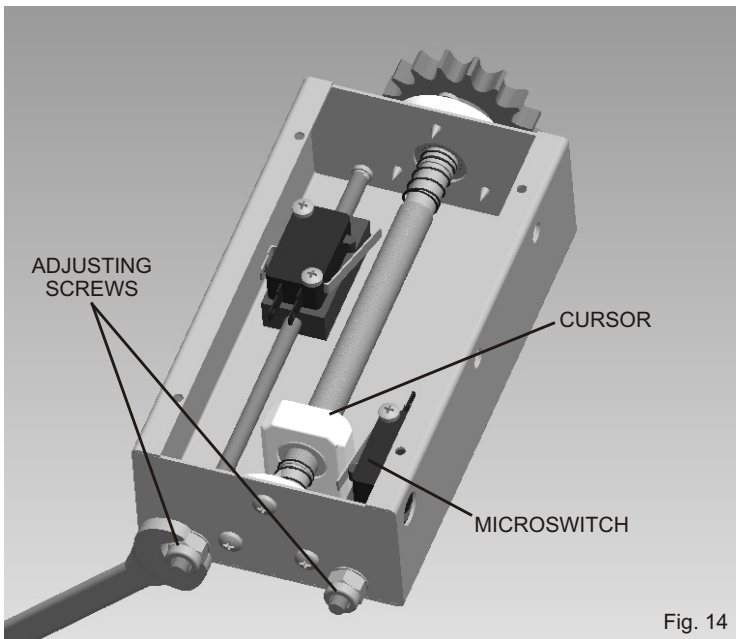

To install and adjust the limit switches in closing, see the following instructions:

- release the motor reducer
- bring the gate to the complete closing
- act on the adjusting screw so that the microswitch can activate the contact with the cursor (Fig. 15)

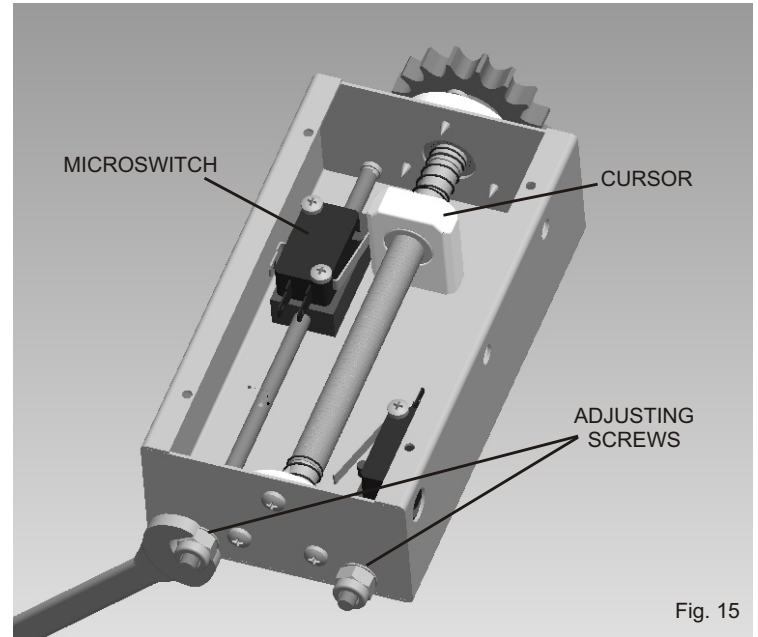

To have a more accurate adjustment, act on the adjusting screws in the testing phase, after having executed the previous operations.

Notice: to adjust the way of the gate run in opening and in closing, make reference to the instructions of the electronic control unit.

### CLUTCH ADJUSTMENT

To adjust the clutch act as follows:

- Turn the stop of the electronic equipment as in Fig. 16 to act on the clutch with an hexagonal key.
- Act on the "A" screw (Fig. 17) in the following way:
  - Clockwise = less clutch sensibility and more pushing force
  - Anti-clockwise = more clutch sensibility and less pushing force

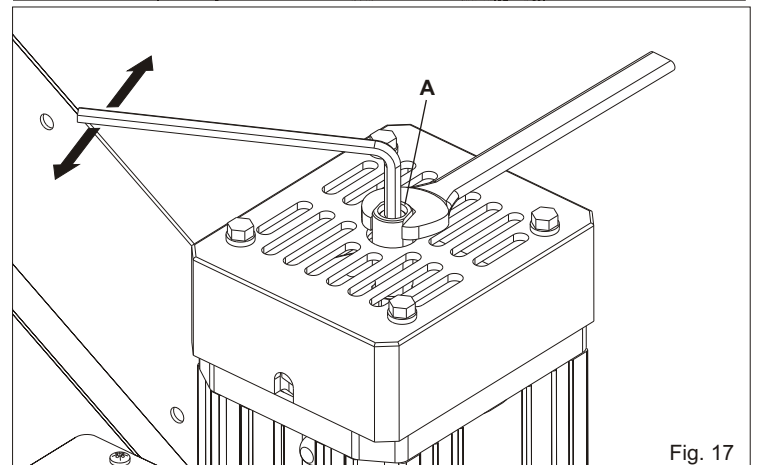
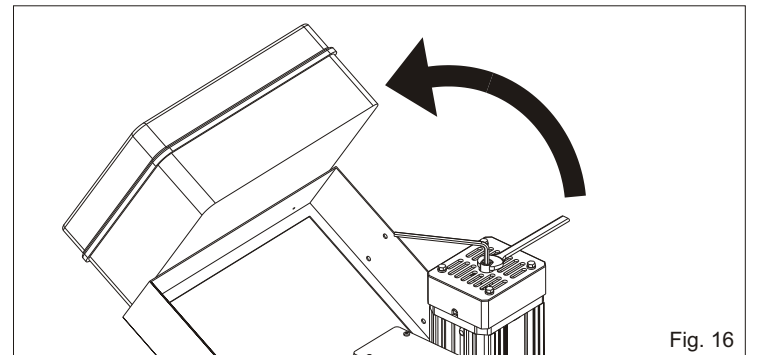

## FITTING AND CONNECTION INSTRUCTIONS

### CABLE LAYOUT

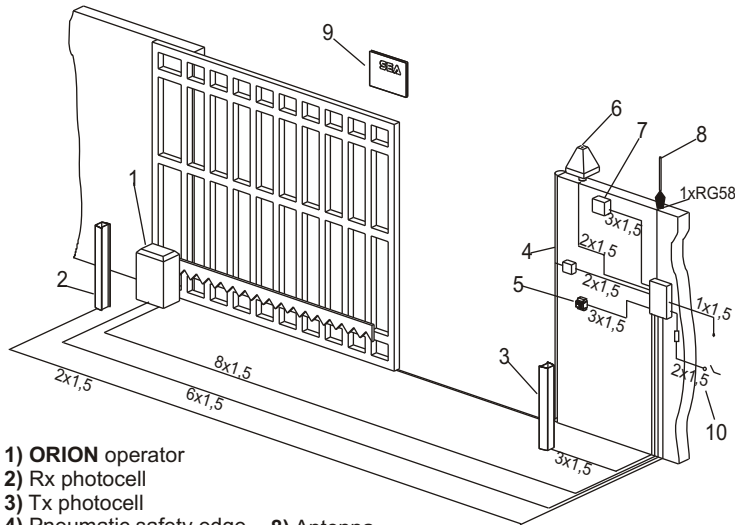

- 1) ORION operator
- 2) Rx photocell
- 3) Tx photocell
- 4) Pneumatic safety edge
- 5) Key switch
- 6) Flashing warning lamp
- 7) Radio receiver
- 8) Antenna
- 9) Warning notice
- 10) RCD Circuit breaker 16A- 30mA

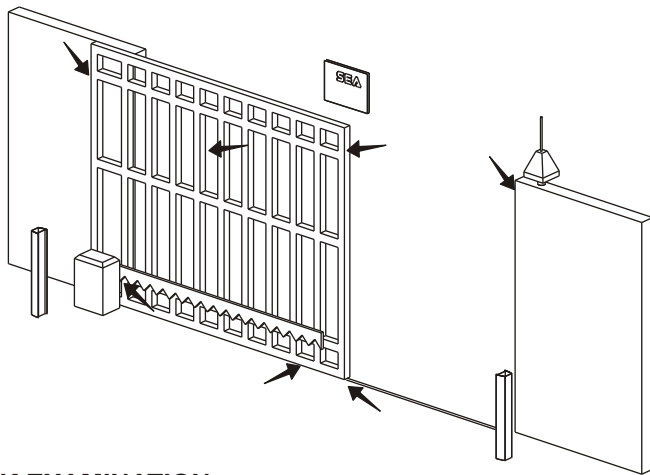

### RISK EXAMINATION

The points pointed by arrows are potentially dangerous. The installer must take a thorough risk examination to prevent crushing, conveying, cutting, grappling, trapping so as to guarantee a safe installation for people, things and animals. (Re. Laws in force in the country where installation has been made.)

As for misunderstandings that may arise refer to your area distributor or call our help desk. These instructions are part of the device and must be kept in a well known place. The installer shall follow the provided instructions thoroughly. SEA USA Inc. products must only be used to automatise doors, gates and l wings. Any initiative taken without SEA USA Inc. explicit authorization will preserve the manufacturer from whatsoever responsibility. The installer shall provide warning notices on not assessable further risks. SEA USA Inc. in its relentless aim to improve the products, is allowed to make whatsoever adjustment without giving notice. This doesn't oblige SEA USA Inc. to up-grade the past production. SEA USA Inc. can not be deemed responsible for any damage or accident caused by product breaking, being damages or accidents due to a failure to comply with the instructions herein. The guarantee will be void and the manufacturer responsibility will be nullified if SEA USA Inc. original spare parts are not being used. The electrical installation shall be carried out by a professional technician who will release documentation as requested by the laws in force. Packaging materials such as plastic bags, foam polystyrene, nails etc must be kept out of children's reach as dangers may arise.

### IMPORTANT SAFETY INSTRUCTIONS

**WARNING - To reduce risk of severe injury or death: READ AND FOLLOW ALL INSTRUCTIONS**

Never let children operate or play with door controls. Keep the remote control away from children.

Always keep the moving system in sight and away from people and objects until it is completely closed or stopped. **NO ONE SHOULD CROSS THE PATH OF THE MOVING SYSTEM.**

**Test the system opener monthly.** The system **MUST** reverse on contact with a 1 - 1/2 inch high object (or a 2 by 4 board laid flat) on the floor. After adjusting either the force or the limit of the travel, retest the door opener. Failure to adjust the opener properly increases the risk of severe injury or death. For products having an emergency release use it only when the door is closed. Use caution when using this release with the door open. Weak or broken springs are capable of increasing the rate of door closure and increasing the risk of severe injury or death.

**KEEP THE SYSTEM PROPERLY BALANCED AND MAINTAINED.** An improper balancing or maintaining increases the risk of severe injury or death. Have a qualified service person make repairs to cables, spring assemblies and other hardware.

Vehicular gate operator systems offer convenience to their users and limit vehicular traffic onto your property. Gate operator systems can and do produce high levels of force. It is important that you are aware of the possible hazards associated with your gate operator system. Hazards may include, but are not limited to pinch points, entrapment, absence of reversing devices, absence of pedestrian access, traffic backup, etc.

Your installer should instruct you on the proper operation of your gate operator system. You and your installer should review the basic functions of the reversing devices on your gate operator system and how to periodically test them. Reversing devices include one or more of the following: reversing loops, photo-eyes, reversing edges, etc. Your installer needs to instruct you on how to remove the gate operator system from service, shut power off at service panel and how to use the gate operator system manually.

**Do not allow children or pets to play in the area of the gate and gate operator system. Do not allow children to play with any access control device.**

Operate gate only when fully visible, properly adjusted and free of obstructions. The owner/operator and/or installer should determine, prior to use, whether the equipment and optional devices, or combination thereof are suitable and safe for the use intended. Since individual installations may be subject to many variations and are usually augmented by devices not always obtained from or through SEA USA Inc. and since SEA USA Inc. has no control over the end use of the products it distributes, SEA USA Inc. makes no representations or warranties as to the suitability of safety of this equipment for a specific application.

Warranty void if unit was installed and/or wired improperly, used wrong power source, used wrong hydraulic fluid, or if damage was caused by fire, flood, lightning or any other acts of God.

This manual is your property. Please keep for future reference.

