

Distributed by:

JAMECO[®]
ELECTRONICS

www.Jameco.com ♦ 1-800-831-4242

The content and copyrights of the attached
material are the property of its owner.

Jameco Part Number 487411

FCC Compliance Statement

This equipment has been tested and found to comply with the limits for a Class B digital device, pursuant to Part 15 of the FCC Rules. These limits are designed to provide reasonable protection against harmful interference in a residential installation. This equipment generates, uses and can radiate radio frequency energy and, if not installed or used in accordance with the instructions, may cause harmful interference to radio communications. However, there is no guarantee that interference will not occur in a television reception, which can be determined by turning the equipment off and on, the user is encouraged to try and correct the interference by one or more of the following measures: (1) Reorient or relocate the receiving antenna. (2) Increase the separation between the equipment and the receiver. (3) Connect the equipment into an outlet on a circuit different from that to which the receiver is connected. (4) Consult the dealer or an experienced radio/TV technician for help.

FCC WARNING

Changes or modifications not expressly approved by the party responsible for compliance could void the user's authority to operate the equipment.

Acknowledgment & Trademark

All contents are subject to change at any time without notice. No responsibility is assumed for its use; nor for infringements of patents or other rights of third parties and no patent or license is implied hereby.

All trademarks are the property of their respective owners.



Safety Notice

1. Do not install or operate the product in high temperature, humidity or dusty environment.
2. Do not attempt to open the cover to repair the product yourself.
3. Never spill liquid of any kind on the product.
4. Always follow instructions on this manual under operating the product.
5. To prevent exposure to laser emanations(harmful to human eyes), do not attempt to disassemble this unit.
6. Hold CD discs by their edges. Do not touch the surface of the discs.
7. The drive is designed to be incorporated into a computer-based system or unit which has an enclosing cover. Using the drive alone or in any other configuration is prohibited.

Caution: Use of controls or adjustments or performance of procedures other than those specified herein may result in hazardous radiation exposure.

WARNING

Do not use fragile disc, it may crack during high speed reading.

WARNHINWEIS

Verwenden Sie keine zerbrechlichen Disketten, da diese bei einer hohen Drehgeschwindigkeit beim Lesen beschädigt werden können.

ADVERTENCIA

No use disco frágil, podría romperse durante la lectura de alta velocidad.

AVERTISSEMENT

N'utilisez pas de disque fragile, il pourrait se briser pendant la lecture à haute vitesse.

AVVISO

Non usare un disco fragile. Potrebbe spaccarsi durante la lettura ad alta velocità.

WAARSCHUWING

Gebruik geen breekbare disks, deze zouden gedurende het op hoge snelheid afspelen kunnen barsten.

警告

請勿使用品質不良光碟片以免光碟機高速運轉讀取資料時而造成光碟片損毀。

HARDWARE INSTALLATION

1. Turn off your PC and disconnect all power cords.
2. Refer to your PC user's manual to remove the PC cover.
3. Set up your CD-ROM to Master or Slave device according to the following section.
4. Find an empty bay, slide the CD-ROM into the bay and mount the drive by using 4 screws.
5. Connect the power cable to your CD-ROM drive.

NOTE: The pin definition of power connector should be the same as that in figure 1.
6. Connect the E-IDE cable (40 pin) to your CD-ROM according to the description in the following section.
7. Connect the sound cable from the Analog Audio on the rear panel of your CD-ROM to your sound card if you have a sound card in your system.

NOTE: The R channel is normally in red color.
8. Put the PC cover back and connect the power cords.

Set Master or Slave Jumper

There are three pairs of jumpers, MA(Master), SL(Slave) and CS(CSEL) on the rear panel of your CD-ROM drive. Figure 1 shows the location of the jumper.

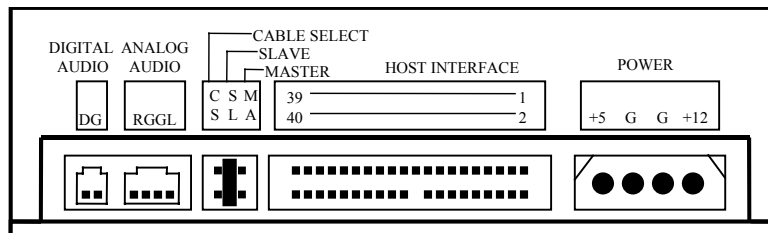

Figure 1: Rear panel of CD-ROM drive

The *Master/Slave* jumper can be used to set the CD-ROM drive to *Master* or *Slave* device. Figure 2 is the illustration of jumper setting.

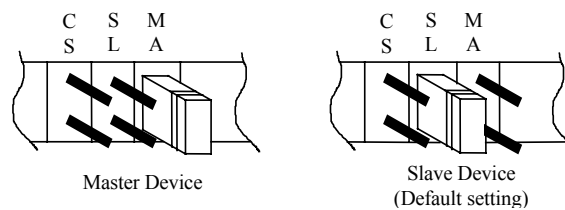

Figure 2: The setting of Master or Slave device.

NOTE: Do not use two jumpers to set MA and SL simultaneously.

Connect to Primary/Secondary IDE Port

In most of the PC systems, the hard disk will be in *Primary IDE* port and *Master* device for the PC to boot the operating system. CD-ROM drive should be set to *Slave* device if you need to connect your CD-ROM to the same *Primary IDE* port. In some situations, you may need to connect your CD-ROM drive to *Secondary IDE* port if the *Primary IDE* port is occupied. In this configuration, the CD-ROM drive can be set to *Master* device if there is no any other device in this *Secondary IDE* port. Otherwise, the CD-ROM drive should be set to *Slave* device if *Master* device already exists. Figure 3 shows the setting and the connection of your CD-ROM to *Primary IDE* port or to *Secondary IDE* port. Table 1 illustrates the configuration of your CD-ROM if you want to use *Secondary IDE* port.

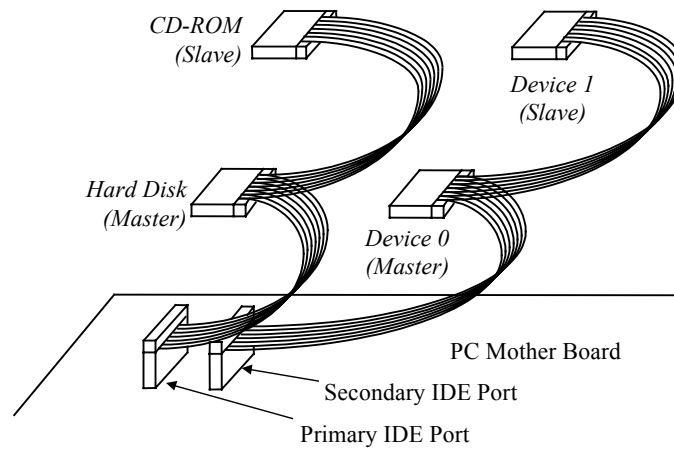

Figure 3: The connection of Primary or Secondary IDE Port.

Device \ Mode	Device 0 (Master)	Device 1 (Slave)
One device	CD-ROM	None
Two devices	Hard disk or CD-ROM	CD-ROM

Table 1: The configuration of Secondary IDE Port.

SOFTWARE INSTALLATION

There is a *device driver diskette* in your CD-ROM drive package. The *device driver* is needed if your PC system is in DOS or Windows 3.1 or higher. Please follow the procedures listed below if you need to install the *device driver* in your system. Usually the *device driver* is not necessary if you run the Windows 95/98/2000/XP. Please refer the following procedures or the user's guide of the operating system if the CD-ROM can't be recognized automatically.

DOS or Windows 3.x

1. Power on your PC and insert the *driver diskette* into a floppy drive.
2. Type **A:(a:) or B:(b:)** where the *driver diskette* locates.
3. Type **Install** under DOS prompt and Press **Enter** key.
4. Follow the instruction on the screen.
5. After the installation, remove the *driver diskette* and *reboot* your system.

Windows 95/98/2000/XP

There is no need to install any CD-ROM device driver under Windows 95/98/2000/XP system. Please follow steps below if your CD-ROM can't be recognized automatically.

1. Start-up your PC, the system will detect the new CD-ROM drive and use the software device driver automatically. If not, please proceed the next steps.
2. Click on Control Panel icon under My Computer.
3. Click on Add New Hardware icon and Click Next and Yes at the dialog boxes.
4. Follow the instructions on the screen and let Windows 95/98/2000/XP search your new hardware. It will find the CD-ROM drive and load the driver software to complete the installation.

NOTE: Please read the *README* file on the driver diskette for any updates made after this manual.

USING THE CD-ROM DRIVE

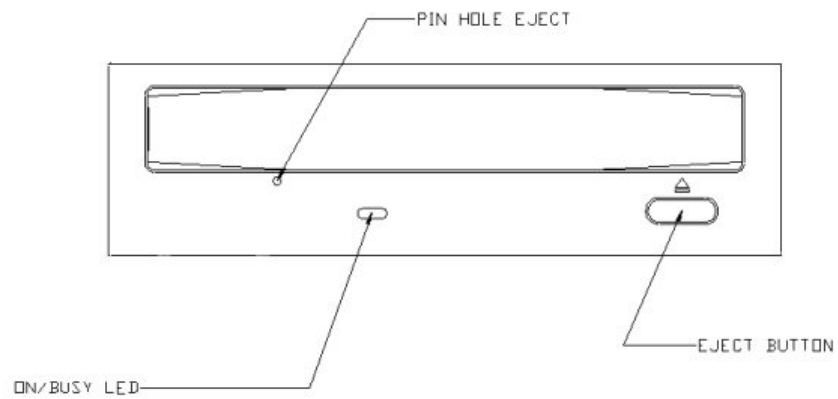

Figure: Front view of CD-ROM

A	Eject/Close Button	Push button to eject/close the tray.
B	On/Busy LED	The On/Busy LED will be flashing while the CD-ROM disc is busy.
C	Emergency Eject Hole	In case the Eject button isn't working, insert a small stick or paper clip into this hole to eject the tray. <i>Note: Turn off the power before doing this manual ejection.</i>

P/N: 7819900081B