



MicroLogix™ 1000 Programmable Controllers and Hand-Held Programmer

(Catalog Numbers 1761-L16AWA, -L16BWA, -L32AWA,
-L32BWA, -L16BBB, -L32BBB, -L16BWB, -L32BWB,
-L32AAA, and 1761-HHP-B30)

Product Data

Product Data

MicroLogix 1000 Programmable Controllers and Hand-Held Programmer

Benefits

The MicroLogix™ 1000 Programmable Controller from Allen-Bradley is the micro controller that is just right for your application. These controllers offer you product breadth, outstanding performance, superior reliability, and Allen-Bradley quality.

The MicroLogix 1000 Programmable Controller family offers a full line of micro controllers. The controllers are available in two I/O sizes and five electrical configurations to meet your application needs. The controllers are either AC or DC powered with AC or DC inputs. Available outputs include relay outputs for controlling AC or DC loads, triac outputs for controlling AC loads, or MOSFET outputs for controlling DC loads.

MicroLogix 1000 Programmable Controllers are designed using the latest technology, providing outstanding performance to keep your application running smoothly. Execution speed, I/O flexibility, and development tool diagnostics all contribute to make the MicroLogix 1000 Programmable Controller family your first choice when deciding on a control system.

Designed and tested for a variety of applications, the MicroLogix 1000 Programmable Controller family provides superior reliability and will stand up to your daily routine. The MicroLogix 1000 Programmable Controllers and development tools are constructed with state of the art manufacturing techniques such as single board construction and double-sided surface mounting; minimizing the number of parts, reducing size, and increasing reliability.

The MicroLogix 1000 Programmable Controller family adheres to Allen-Bradley quality standards. Over 90 years of Allen-Bradley manufacturing, sales, and support experience go into each MicroLogix 1000 Programmable Controller and development tool.

What's Inside...	Page
Overview of the MicroLogix 1000 Programmable Controller Family	3
MicroLogix 1000 Programmable Controllers Operating Features	4
Development Tools	7
Operator Interface	10
Programming Instructions	11
Calculating Controller Memory Usage	16
Calculating Program Execution Time	16
Support	17
MicroLogix 1000 User Documentation	17
MicroLogix 1000 Programmable Controllers Specifications	18
Hand-Held Programmer Specifications	21
MicroView™ Operator Interface Specifications	22

Overview of the MicroLogix 1000 Programmable Controller Family

The MicroLogix 1000 Programmable Controller family offers you several types of controllers, three development tools, and one operator interface to meet your control needs in a variety of application segments including:

- building controls
- cutting tools
- civil engineering
- custom machinery
- farm equipment
- fluid handling
- food processing
- furnaces, burners, and dryers
- general industrial machinery
- material handling
- metal working
- packaging machinery
- specialized industrial machinery
- transportation

MicroLogix 1000 Programmable Controllers

The MicroLogix 1000 Programmable Controllers are designed to electronically control your application. The controllers are available in either 16 I/O points (10 inputs and 6 outputs) or 32 I/O points (20 inputs and 12 outputs) in 5 electrical configurations. The I/O options and electrical configurations make them ideal for almost any application.

The controllers are programmed in familiar ladder logic. This symbolic programming language is based on relay ladder wiring diagrams that simplify the creation and troubleshooting of your control program. The comprehensive instruction set includes simple bit, timer, and counter instructions as well as powerful application instructions such as sequencers, high-speed counter, and shift registers.

Development Tools

To get your application running smoothly, you need a quick and simple way to program your controller. The MicroLogix 1000 Programmable Controller family offers you two software packages and one diagnostic hand-held programmer to help you accomplish this task.

Operator Interface

The MicroView Operator Interface enables you to monitor and control your application with a combination of large memory capacity, flexible file addressing, user-defined function keys, and an easy-to-read display. Contact your local Allen-Bradley distributor for more information concerning the MicroView Operator Interface and accessories.

MicroLogix 1000 Programmable Controllers Operating Features

The MicroLogix 1000 Programmable Controllers' list of impressive hardware, memory, and processing features makes this family of controllers the ideal choice for applications under 32 I/O. The features include:

Hardware Features

- Two I/O point sizes (i.e., 16 and 32 I/O). Covers a breadth of applications.
- Five electrical configurations. Offers you a controller that meets your electrical requirements:
 - 24V dc inputs and relay outputs with a 120/240V ac power supply
 - 120V ac inputs and relay outputs with a 120/240V ac power supply
 - 24V dc inputs and relay outputs with a 24V dc power supply
 - 24V dc inputs and 24V dc FET and relay outputs with a 24V dc power supply
 - 120V ac inputs and triac and relay outputs with a 120/240V ac power supply
- five output commons on relay output units and three on MOSFET units (at least two isolated relays per controller). Allows outputs on the same unit to switch different control voltages.
- multiple input commons. Allows the controller with DC inputs to accept sink and source type sensors.
- compact size. Enables the MicroLogix 1000 Programmable Controller to fit in tight spaces.
- adjustable DC input filters. Allows you to customize your input response time to various applications. Refer to page 19 for a listing of the adjustable DC input filter settings.
- built-in sensor DC power supply on AC powered units. Eliminates the need for an external DC power supply in many applications.
- RS-232 communication channel. Allows you to connect the controller directly to your personal computer or telephone modem.
- auto-ranging AC power supply. Allows you to install the MicroLogix 1000 Programmable Controller in virtually any application worldwide.
- OEM protection. Allows you to protect proprietary algorithms, prevent program alterations, and stop unauthorized access to the controller.

Product Data

MicroLogix 1000 Programmable Controllers and Hand-Held Programmer

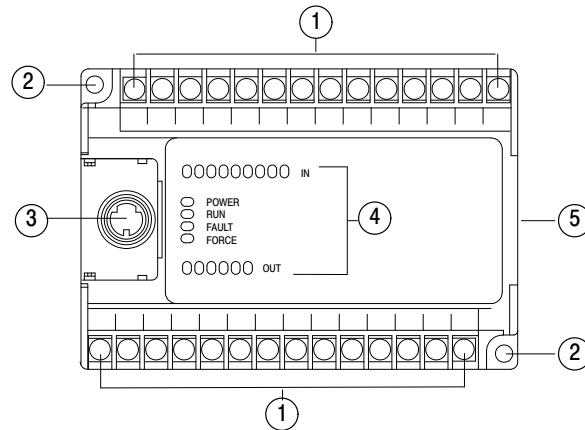

20142

- ① Horizontally positioned input (top) and output (bottom) terminals. Allows for easy hookup.
- ② Easily accessible mounting holes. Allows for quick installation.
- ③ RS-232 channel. Allows for easy connectivity with your programming device.
- ④ Centrally located LEDs. Makes diagnostics easier to perform.
- ⑤ Centrally located DIN rail. Allows for quick installation.

Memory Features

- built-in EEPROM memory. Retains your program and all of your data if your controller loses power, eliminating the need for battery or capacitor backup.
- optimized 1K user memory capacity. Provides ample memory to meet your application needs including:
 - over 735 word application program
 - more than 250 data words comprised of 512 bits, 40 timers, 32 counters, 16 controls, 105 integers, and 33 diagnostic registers
- comprehensive instruction set. Allows you to develop a program using over 65 programming instructions from the following categories:
 - bit
 - timer/counter
 - comparison
 - math
 - data handling
 - program flow
 - application specific (e.g., sequencer, shift register, and FIFO/LIFO)
 - high-speed counter
- efficient instructions. Condenses multiple rungs into a single instruction. For example, a drum sequencer only requires 2 instruction words.

Processing Features

- superior high-speed counter. Offers immediate control of program outputs since the high-speed counter operates independent of the program scan. In addition, the high-speed counter provides:
 - high count frequency of 6.6 kHz
 - eight operating modes including up count, bi-directional, and quadrature
 - interrupt latency of less than 1ms
- fast throughput. Allows for typical throughput time of 1.5 ms for a 500 instruction program.^① Throughput is the time it takes for the controller to sense an input to the time of controlling a corresponding output. To calculate your program execution time, refer to page 16.

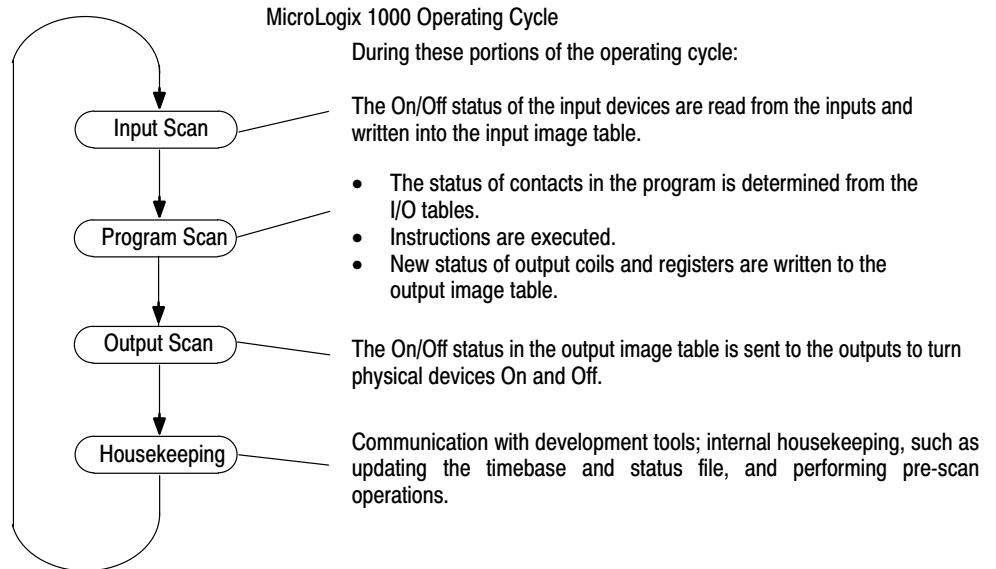

^① A typical program contains 360 contacts, 125 coils, 7 timers, 3 counters, and 5 comparison instructions.

Development Tools

To make the MicroLogix 1000 Programmable Controller operational, you use one of three distinct development tools available:

- MicroLogix 1000 Programming Software (v1.0 or later)
- Advanced Programming Software (v5.1 or later)
- Hand-Held Programmer

Both software packages allow you to create, edit, document, and troubleshoot ladder logic programs with an IBM[®] compatible PC.

MicroLogix 1000 Programming Software

MicroLogix 1000 Programming Software (v1.0 or later) is used to program the MicroLogix 1000 Programmable Controller family.

Advanced Programming Software

Advanced Programming Software (v5.1 or later) is a development tool worth considering because it allows you to program both the MicroLogix 1000 Programmable Controllers and the SLC 500™ Programmable Controllers with a single software package.

Software Features

Both the MicroLogix 1000 Programming Software (v1.0 or later) and APS software (v5.1 or later) offer:

- program documentation. Allows you to add comments to rungs, instructions, and addresses.
- online context sensitive help. Makes programming and troubleshooting easier to perform.
- cut, copy, and paste editor. Allows you to efficiently modify your ladder logic program.
- search and replace. Allows quick modification of ladder logic to accommodate program changes.
- RS-232 DF1 full duplex protocol. Supports remote programming through a telephone modem.
- program reports. Allows you to create processor configuration, cross-reference, program listing, and data table reports.
- global language support. Provides separate programming packages in English, French, German, Italian, and Spanish.
- command line entry of instructions and parameters. Saves time by reducing keystrokes.

System Requirements

Both the MicroLogix 1000 Programming Software (v1.0 or later) and APS (v5.1 or later) can be used with:

- Allen-Bradley T47 or T70 terminal
- 386/SX
- NEC VERSA™ E Series Notebook
- GATEWAY 2000™ models 386DX/25, 386DX33, 486DX/33, 486DX2/50, and 486DX2/66 personal computers

The computer must have:

- 640 Kbytes of RAM (At least 2 meg. of extended memory is required.)
- 10 Mbyte fixed-disk drive (APS requires 3.5 Mbytes of free disk space.)
- DOS version 3.3 or higher

Hand-Held Programmer

The Hand-Held Programmer (HHP) uses an enhanced Instruction List that is accepted worldwide for programming the MicroLogix 1000 Programmable Controllers. The HHP is an ideal service tool and programmer that easily and conveniently travels to where the controller is located. With the HHP you can:

- monitor and troubleshoot controller operation
- create, enter, and modify application programs
- store application programs
- transfer programs between controllers

Hand-Held Programmer Features

- optional EEPROM memory modules. Offers you two convenient and safe ways to store or transfer up to eight programs (in 8K or 64K sizes) between MicroLogix 1000 Programmable Controllers. The memory module is located in the back of the HHP.
- trace function. Allows you to quickly find faulty elements that prevent an output from turning on or off, saving valuable troubleshooting time.
- multipoint monitor. Allows you to monitor your most crucial bit addresses at the same time. All 16 addresses are stored with the controller.
- context-sensitive keys. Reduces number of keystrokes when entering and monitoring programs.
- small size. Makes the HHP easy to carry around and store.
- global programmer. Allows programming in English, French, German, Italian, Spanish, and Japanese through a multilingual display.
- textual fault messages. Gives fault code and messages in any of six languages making troubleshooting easier to perform.
- graphic display. Allows you to program with the familiar basic ladder logic programming symbols.
- rung-based navigation. Permits easy movement through your program.

Product Data



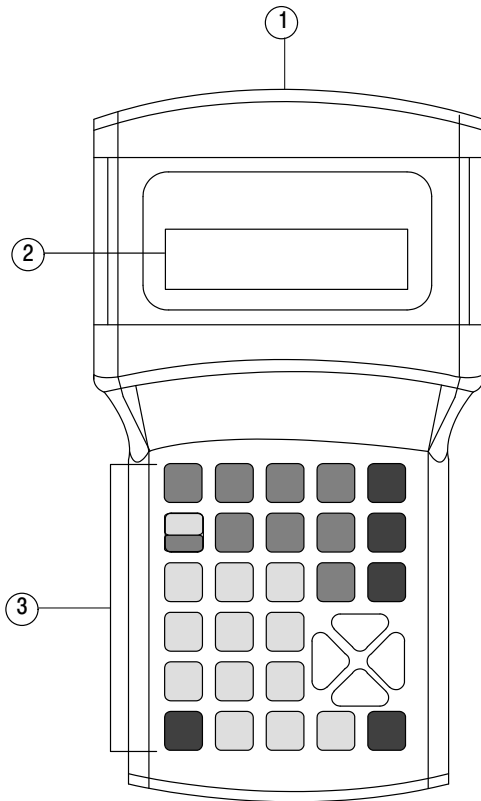

MicroLogix 1000 Programmable Controllers
and Hand-Held Programmer

Front View

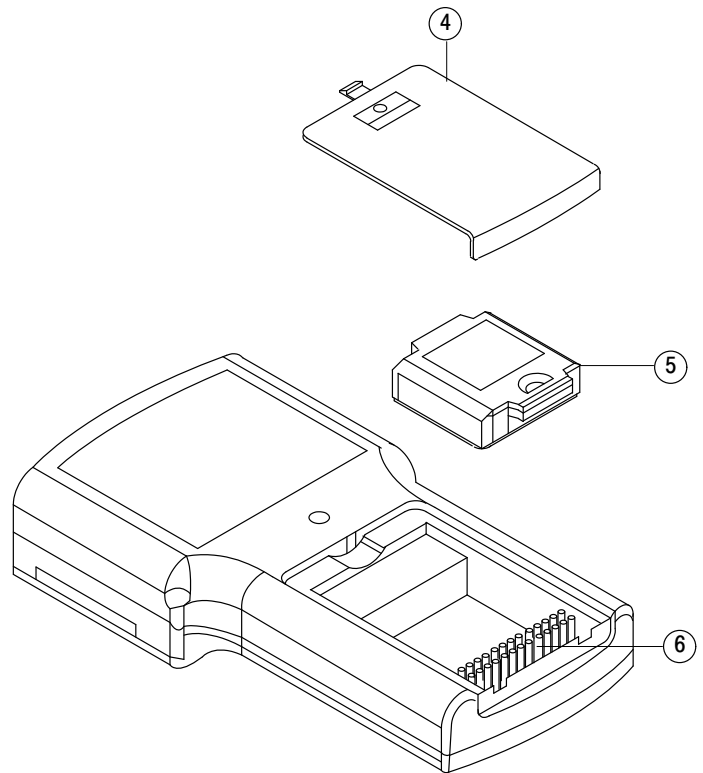

Back View



- ① RS-232 interface. Allows for easy connectivity to controller.
- ② 16 character \times 2 line display. Allows for more complete messages.
- ③ 30 color coded keys. Provides the following:
 -  start-up/diagnostic keys. Allows you to get your system up and running and keep it running.
 -  instruction keys. Allows you to enter all of your program's instructions.
 -  general editing keys. Allows you to make changes in a snap.
 -  navigation keys. Allows you to move through the entire program quickly and easily.

- ④ memory module door. Allows you access to the optional memory module.
- ⑤ optional memory module. Provides storage for up to eight programs.
- ⑥ memory module socket. Allows you to easily connect the memory module into the HHP.

Product Data

MicroLogix 1000 Programmable Controllers
and Hand-Held Programmer

Operator Interface

The MicroView Operator Interface is a feature packed operator interface for plant floor control and data monitoring.

MicroView Operator Interface Features

- RS-232 DF1 compatible. Allows you to communicate with the MicroLogix 1000 Programmable Controllers.
- Compact Size. Makes the MicroView Operator Interface easy to use in applications with limited space.
- Panel mount adapter with connector. Allows you to easily remove the MicroView Operator Interface for programming or replacement.
- Offline configuration software. Allows you to create additional screen displays such as data display, data entry, and recipe screens.
- Point-access. Allows you to monitor or modify data files in the MicroLogix 1000 Programmable Controllers independently of programmed screens.
- Standard file access. Allows you to access data tables for I/O, status, binary, timer, counter, control, and integer files.
- Memory capability. Allows you to store up to 50 application screens and configuration data.
- Function keys. Provides you with a quick and convenient way to automatically trigger screen displays and control screen navigation as well as set or clear data table bits.

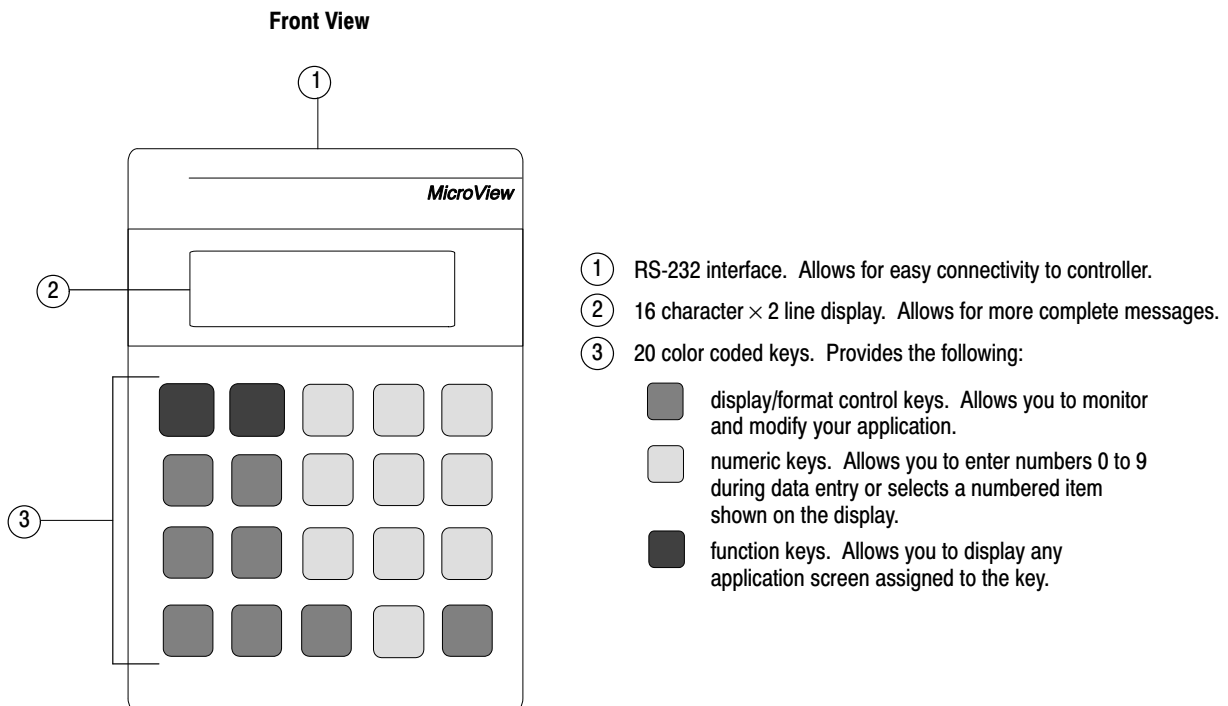

Programming Instructions

The following tables of instructions are used to program your MicroLogix 1000 Programmable Controller with either the MicroLogix 1000 Programming Software (v1.0 or later) or APS (v5.1 or later) or the HHP.

Bit Instructions

These instructions operate on a single bit of data. During operation, the controller may set or reset the bit, based on the input status or logical continuity of a rung. You can program a bit as many times as your program requires.

Instruction			Purpose	User Words Required	Execution Time (approx. μ seconds) ^①
Name	Mnemonic	Symbol			
Examine if Closed	XIC	$\neg I$	Examines a bit for an On condition.	0.75	1.54
Examine if Open	XIO	\neg /I	Examines a bit for an Off condition.	0.75	1.54
Output Energize	OTE	$\neg ()$	Turns a bit On or Off.	0.75	4.43
Output Latch and Output Unlatch	OTL and OTU	$\neg (L)$	OTL turns a bit on when the rung is true. This bit retains its state until it is reset by a true OTU instruction. A power cycle does not affect the status of the bit controlled by these instructions.	0.75	4.97
		$\neg (U)$		0.75	4.97
One-Shot Rising	OSR	Not Applicable	Triggers a one time event.	1	13.02

^① The times listed are for a true execution of the instruction. The false execution times are slightly less.

Timer/Counter Instructions

Timer instructions are used to control an output after a set time period. Counter instructions are used to control an output after a set number of counts.

Instruction		Purpose	User Words Required	Execution Time (approx. μ seconds) ^②
Name	Mnemonic			
Timer On-Delay	TON	Counts timebase intervals when the instruction is true.	1	38.34
Timer Off-Delay	TOF	Counts timebase intervals when the instruction is false.	1	39.42
Retentive Timer	RTO	Counts timebase intervals when the instruction is true and retains the accumulated value when the instruction goes false or when power cycle occurs.	1	38.34
Count Up	CTU	Increments the accumulated value at each false-to-true transition of the rung and retains the accumulated value when power cycle occurs.	1	29.84
Count Down	CTD	Decrements the accumulated value at each false-to-true transition of the rung and retains the accumulated value when power cycle occurs.	1	32.19
Reset	RES	Resets the accumulated value and status bits of a timer or counter. Do not use with TOF timers.	1	15.19

^① The times listed are for a true execution of the instruction. The false execution times are slightly less.

Product Data

MicroLogix 1000 Programmable Controllers
and Hand-Held Programmer

Comparison Instructions

Comparison instructions are used to test pairs of values to condition the logical continuity of a rung.

Instruction		Purpose	User Words Required	Execution Time (approx. μ seconds) ^①
Name	Mnemonic			
Equal	EQU	Test whether two values are equal.	1.5	21.52
Not Equal	NEQ	Test whether one value is not equal to a second value.	1.5	21.52
Less Than	LES	Test whether one value is less than a second value.	1.5	23.60
Less Than or Equal	LEQ	Test whether one value is less than or equal to a second value.	1.5	23.60
Greater Than	GRT	Test whether one value is greater than another.	1.5	23.60
Greater Than or Equal	GEQ	Test whether one value is greater than or equal to a second value.	1.5	23.60
Masked Comparison for Equal	MEQ	Test portions of two values to see whether they are equal. Compares 16-bit data of a source address to 16-bit data at a reference address through a mask.	1.5	28.39
Limit Test	LIM	Test whether one value is within the limit range of two other values.	1.5	36.93

^① The times listed are for a true execution of the instruction. The false execution times are slightly less.

Math Instructions

The math instructions take a pair of values and performs the desired function. The result is placed in a separate location.

Instruction		Purpose	User Words Required	Execution Time (approx. μ seconds) ^①
Name	Mnemonic			
Add	ADD	Adds source A to source B and stores the result in the destination.	1.5	33.09
Subtract	SUB	Subtracts source B from source A and stores the result in the destination.	1.5	33.52
Multiply	MUL	Multiplies source A by source B and stores the result in the destination.	1.5	57.96
Divide	DIV	Divides source A by source B and stores the result in the destination and the math register.	1.5	147.87
Double Divide	DDV	Divides the contents of the math register by the source and stores the result in the destination and the math register.	1	157.06
Clear	CLR	Sets all bits of a word to zero.	1	20.80
Square Root	SQR	Calculates the square root of the source and places the integer result in the destination.	1.25	71.25
Scale Data	SCL	Multiplies the source by a specified rate, adds to an offset value, and stores the result in the destination.	1.75	169.18

^① The times listed are for a true execution of the instruction. The false execution times are slightly less.

Data Handling Instructions

Data handling instructions are used to convert information, manipulate data in the controller, and perform logic operations.

Instruction		Purpose	User Words Required	Execution Time (approx. μ seconds) ^①
Name	Mnemonic			
Convert to BCD	TOD	Converts the integer source value to BCD format and stores it in the destination.	1.0	49.64
Convert from BCD	FRD	Converts the BCD source value to an integer and stores it in the destination.	1	56.88
Decode 4 to 1 of 16	DCD	Decodes a 4-bit value (0 to 15), turning on the corresponding bit in the 16-bit destination.	1.5	27.67
Encode 1 of 16 to 4	ENC	Searches the source from the lowest to the highest bit, and looks for the first set bit. The corresponding bit position is written to the destination as an integer.	1.5	54.80
Copy File and Fill File	COP and FLL	The COP instruction copies data from the source file to the destination file. The FLL instruction loads a source value into each position in the destination file.	1.5	27.31 + 5.06 per word
			1.5	26.86 + 3.62 per word
Move	MOV	Moves the source value to the destination.	1.5	25.05
Masked Move	MVM	Moves data from a source location to a selected portion of the destination.	1.5	33.28
And	AND	ANDs value at source A bit by bit with value at source B and stores value at destination.	1.5	34.00
Or	OR	ORs value at source A bit by bit with value at source B and stores value at destination.	1.5	33.64
Exclusive Or	XOR	Exclusively ORs value at source A bit by bit with value at source B and stores value at destination.	1.5	33.64
Not	NOT	NOTs value at source bit by bit and is stored in the destination (one's complement).	1	28.21
Negate	NEG	Changes the sign of the source and stores it in the destination.	1.5	29.48
FIFO Load and FIFO Unload	FFL and FFU	The FFL instruction loads a word into a FIFO stack on successive false-to-true transitions. The FFU unloads a word from the stack on successive false-true transitions. The first word loaded is the first to be unloaded.	1.5	61.13
			1.5	73.78 + 4.34 x position value
LIFO Load and LIFO Unload	LFL and LFU	The LFL instruction loads a word into a LIFO stack on successive false-to-true transitions. The LFU unloads a word from the stack on successive false-to-true transitions. The last word loaded is the first to be unloaded.	1.5	61.13
			1.5	64.20

^① The times listed are for a true execution of the instruction. The false execution times are slightly less.

Product Data**MicroLogix 1000 Programmable Controllers
and Hand-Held Programmer****Program Flow Control Instructions**

Program flow instructions are used to control the sequence in which your program is executed.

Instruction		Purpose	User Words Required	Execution Time (approx. μ seconds) ^①
Name	Mnemonic			
Jump to Label and Label	JMP and LBL	Jump forward or backward to the specified label instruction.	1 0.5	9.04 1.45
Jump to Subroutine, Subroutine, and Return from Subroutine	JSR, SBR, and RET	Jump to a designated subroutine and return.	1 0.5 0.5	22.24 1.45 31.11
Master Control Reset	MCR	Enable or disable sections of the ladder program.	0.5	3.98
Temporary End	TND	Mark a temporary end that halts program execution.	0.5	7.78
Suspend	SUS	Identifies specific conditions for program debugging and system troubleshooting.	1.5	10.85
Immediate Input with Mask	IIM	Immediately updates input status with mask.	1.5	35.72
Immediate Output with Mask	IOM	Immediately updates output status with mask.	1.5	41.59

^① The times listed are for a true execution of the instruction. The false execution times are slightly less.

Application Specific Instructions

Application specific instructions simplify your ladder program by allowing you to use a single instruction or pair of instructions to perform complex operations.

Instruction		Purpose	User Words Required	Execution Time (approx. μ seconds) ^①
Name	Mnemonic			
Bit Shift Left and Bit Shift Right	BSL and BSR	Loads a bit of data into a bit array, shifts the pattern of data through the array, and unloads the last bit of data in the array. The BSL shifts data to the left and the BSR shifts data to the right.	2 2	53.71 + 5.24 x position value 53.34 + 3.98 x position value
Sequencer Output and Sequencer Compare	SQO and SQC	Control sequential machine operations by transferring 16-bit data through a mask to a destination word.	2 2	60.52 60.52
Sequencer Load	SQL	Capture referenced conditions by manually stepping the machine through its operating sequences.	2	53.41
Selectable Timed Interrupt Disable and Enable	STD and STE	Output instructions, associated with the Selectable Timed Interrupt function. STD and STE are used to prevent an STI from occurring during a portion of the program.	0.5 0.5	6.69 10.13
Selectable Timed Interrupt Start	STS	Initiates a Selectable Timed Interrupt.	1.25	24.59
Interrupt Subroutine	INT	Identifies the beginning of an interrupt associated with Selectable Timed Interrupts or HSC Interrupts.	0.5	1.45

^① The times listed are for a true execution of the instruction. The false execution times are slightly less.

High-Speed Counter Instructions

The high-speed counter instructions are used to perform specific actions after a preset count is reached.

Instruction		Purpose	User Words Required	Execution Time (approx. μ seconds) ^①
Name	Mnemonic			
High-Speed Counter	HSC	Configures the high-speed counter hardware, updates the image accumulator, and disables counting when false.	1	21.00
High-Speed Counter Load	HSL	Configures the low and high presets, output patterns, and mask bit patterns.	1.5	66.00
High-Speed Counter Reset Accumulator	RAC	Writes a specified value to the hardware accumulator and image accumulator.	1	56.00
High-Speed Counter Interrupt Enable and Disable	HSE and HSD	Enables or disables a high-speed counter interrupt to occur when a high preset, low preset, overflow, or underflow is reached.	1.25 1.25	10.00 8.00

^① The times listed are for a true execution of the instruction. The false execution times are slightly less.

Branch Instructions for HHP

The enhanced Instruction List programming ability of the HHP gives you these additional instructions:

Instruction		Purpose	User Words Required	Execution Time (approx. μ seconds)
Name	Mnemonic			
AND Block	ANB	Places two blocks of logic in series with each other (ANDs them).	0.25	0.4
OR Block	ORB	Places two blocks of logic in parallel with each other (ORs them).	0.25	0.4
Memory Push	MPS	Stores the rung state immediately preceding the MPS instruction.	0.25	0.4
Memory Read	MRD	Reads the rung state stored by the MPS instruction and resumes operation using that rung state.	0.25	0.4
Memory Pop	MPP	Removes the rung state from the MPS instruction, reads it, and resumes operation using that rung state.	0.25	0.4

Calculating Controller Memory Usage

Memory usage refers to the amount of memory used by your controller for processing your application program. Total user memory capacity for the MicroLogix 1000 Programmable Controller is 1024 instruction words. Use the following worksheet to calculate memory usage for your control system to determine if your program uses less memory than the controller memory capacity.

Memory Usage Worksheet

1. Determine the total instruction words used by the instructions in your program and enter the result. Refer to the tables starting on page 11.
2. Multiply the total number of rungs by 0.75 and enter the result. Do not count the END rungs in each file.
3. Use 177 to account for processor overhead words used by the controller to run programs.
4. Use 110 to account for application data words preallocated by the controller.
5. Total steps 1–4. This is the estimated total memory usage of your application system. Remember, this is an estimate, actual compiled programs may differ by $\pm 12\%$.
6. To determine the estimated amount of memory remaining in the controller you have selected, do the following:
Subtract the total memory usage from 1024.

	<u>177</u>
	<u>110</u>
Total Memory Usage:	_____
	1024
Total Memory Usage (from above):	—
Total Memory Remaining:	_____

The result of this calculation will be the estimated total memory remaining in your selected controller.

Important: The calculated memory usage may vary from the actual compiled program by $\pm 12\%$.

Calculating Program Execution Time

Execution time refers to the amount of time it takes for your controller to process your application program. Use the following worksheet to determine if your program meets your application timing requirements.

Execution Time Worksheet

Procedure	Maximum Scan Time
1. Input scan time, output scan time, housekeeping time, and forcing.	210 μ s
2. Estimate your program scan time:	
A. Count the number of program rungs in your ladder program.	_____
B. Add up your program execution times when all instructions are true. Include interrupt routines in this calculation. ^①	_____ μ s
3. Estimate your processor scan time:	
Add sections 1 and 2.	_____ μ s
4. Divide your processor scan time by 1000. This is your program execution time.	_____ ms

^① If a subroutine executes more than once per scan, include each subroutine execution time.

Support

In today's competitive environment, when you buy any product, you expect that product to meet your needs. You also expect the manufacturer of that product to back it up with the kind of customer service and product support that will prove you made a wise purchase.

As the people who design, engineer, and manufacture your Industrial Automation Control equipment, Allen-Bradley has a vested interest in your complete satisfaction with our products and services.

Allen-Bradley offers support services worldwide, with over 75 Sales/Support Offices, 512 authorized Distributors and 260 authorized Systems Integrators located throughout the United States alone, plus Allen-Bradley representatives in every major country in the world.

Contact your local Allen-Bradley representative for:

- sales and order support
- product technical training
- warranty support
- support service agreements

Allen-Bradley also offers the *Micro Mentor* (catalog number 1761-MMB). This document provides you with information regarding PLC fundamentals including what a PLC is and how it is used in control applications. For information on getting started with your MicroLogix 1000 Programmable Controller, refer to the Getting Started Video and Specification Guide.

MicroLogix 1000 User Documentation

MicroLogix 1000 user documentation presents information according to the tasks you perform and the programming environment you use:

For information on	See this document	With this publication number
Installing the MicroLogix 1000 Programmable Controller	MicroLogix™ 1000 Programmable Controllers Installation Instructions	1761-5.1
Using the Advanced Programming Software with the MicroLogix 1000 Programmable Controller	MicroLogix™ 1000 with Programming Software User Manual	1761-6.1
Using the HHP with the MicroLogix 1000 Programmable Controller	MicroLogix™ 1000 with Hand-Held Programmer (HHP) User Manual	1761-6.2

User Documentation on CD-ROM

Improve productivity with quicker and easier access to product information. Volumes of Allen-Bradley product documentation are on the DataDisc™ CD-ROM Information Library (cat. nos. 1795-CDRS and 1795-CDRL). Use the search facility to locate all documentation instances of any item you specify. You can view and print the relevant pages.

Product Data

MicroLogix 1000 Programmable Controllers
and Hand-Held Programmer

MicroLogix 1000 Programmable Controllers Specifications

The following tables summarize the specifications and dimensions for the controllers.

Types

Catalog Number	Description
1761-L16AWA	10 pt. AC input, 6 pt. relay output, AC power supply controller
1761-L32AWA	20 pt. AC input, 12 pt. relay output, AC power supply controller
1761-L16BWA	10 pt. DC input, 6 pt. relay output, AC power supply controller
1761-L32BWA	20 pt. DC input, 12 pt. relay output, AC power supply controller
1761-L16BWB	10 pt. DC input, 6 pt. relay output, DC power supply controller
1761-L32BWB	20 pt. DC input, 12 pt. relay output, DC power supply controller
1761-L16BBB	10 pt. DC input, 4 pt. FET and 2 pt. relay outputs, DC power supply controller
1761-L32BBB	20 pt. DC input, 10 pt. FET and 2 pt. relay outputs, DC power supply controller
1761-L32AAA	20 pt. AC input, 10 pt. triac and 2 pt. relay outputs, AC power supply controller

General Specifications

Description:		Specification: 1761-L							
		16AWA	16BWA	32AWA	32BWA	32AAA	16BBB	16BWB	32BBB
Memory Size and Type		1 K EEPROM (approximately 737 instruction words: 437 data words)							
Power Supply Voltage		85–264V ac					20.4–26.4V dc		
Power Supply Usage	120V ac	12 VA	19 VA	16 VA	24 VA	16 VA	Not Applicable		
	240V ac	18 VA	26 VA	22 VA	30 VA	22 VA			
	24V dc	Not Applicable					5 VA	5 VA	7 VA
24V dc Sensor Power (V dc at mA)		Not Applicable	200 mA	Not Applicable	200 mA	Not Applicable			
Max Capacitive Load (User 24 V dc)		Not Applicable	200 μ F	Not Applicable	200 μ F				
Power Cycles		50,000 minimum							
Operating Temperature		0° C to 55° C (32° F to 131° F)							
Storage Temperature		–40° C to 85° C (–40° F to 185° F)							
Operating Humidity		5 to 95% noncondensing							
Vibration		Operating: 5 Hz to 2 kHz, 0.381 mm (0.015 in.) peak to peak/2.5g panel mounted, ^① 1hr per axis							
		Non-operating: 5 Hz to 2 kHz, 0.762 mm (0.030 in.) peak to peak/5g, 1hr per axis							
Shock		Operating: 10g peak acceleration (7.5g DIN rail mounted) ^② (11 \pm 1 ms duration) 3 times each direction, each axis							
		Non-operating: 20g peak acceleration (11 \pm 1 ms duration), 3 times each direction, each axis							
Product Certification		UL listed CSA certified CE compliant for applicable directives when product or packaging is marked							
Terminal Screw Torque		0.9 N-m maximum (8.0 in.-lbs)							
Electrostatic Discharge		IEC801-2 @ 15 KV							
Radiated Susceptibility		IEC801-3 @ 10 V/m, 27 MHz – 1000 MHz							
Fast Transient		IEC801-4 @ 2 KV Power Supply, 1 KV I/O							
Isolation		1500V ac							

^① DIN rail mounted controller is 1g.

^② Relays are derated an additional 2.5g on 32 pt. controllers.

Input Specifications

Description	Specification	
Type	100–120V ac	24V dc
Voltage Range	79 to 132V ac 47 to 63 Hz	15 to 30V dc
On Voltage	79V ac min. 132V ac max.	15V dc min. 24V dc nominal 26.4V dc max. @ 55° C (131° F) 30.0V dc max. @ 30° C (86° F)
Off Voltage	20V ac	5V dc
On Current	5.0 mA min. @ 79V ac 47 Hz 12.0 mA nominal @ 120V ac 60 Hz 16.0 mA max. @ 132V ac 63 Hz	2.5 mA min. @ 15V dc 8.0 mA nominal @ 24V dc 12.0 mA max. @ 30V dc
Off Current	2.5 mA max.	1.5 mA max.
Nominal Impedance	12 Kohms @ 50 Hz 10 Kohms @ 60 Hz	3 Kohms
Inrush Maximum	250 mA max. ^①	Not Applicable

^① To reduce the inrush maximum to 35 mA, apply a 6.8 Kohm, 5w resistor in series with the input. The on-state voltage increases to 92V ac as a result.

DC Input Filter Settings

DC input filters are adjustable as shown below.

Nominal Filter Setting (ms)	Minimum On Delay (ms)	Maximum On Delay (ms)	Minimum Off Delay (ms)	Maximum Off Delay (ms)
0.075 ^①	0.009	0.075	0.009	0.075
0.10 ^①	0.040	0.100	0.040	0.100
0.25 ^①	0.147	0.250	0.147	0.250
0.50	0.014	0.500	0.014	0.500
1	0.091	1.000	0.091	1.000
2	0.618	2.000	0.618	2.000
4	2.441	4.000	2.441	4.000
8	6.256	8.000	6.256	8.000
16	13.37	16.00	13.37	16.00

^① Inputs 0 to 3 only.

AC Input Filter Settings

Nominal Filter Setting (ms) ^①	Minimum ON Delay (ms)	Maximum ON Delay (ms)	Minimum OFF Delay (ms)	Maximum OFF Delay (ms)
8.0	2.0	20.0	10.0	20.0

^① There is only one filter setting available for the AC inputs.

Product Data

MicroLogix 1000 Programmable Controllers
and Hand-Held Programmer

Output Specifications

Description	Specification				
	Relay	MOSFET		Triac	
Type	Relay	MOSFET		Triac	
Voltage	5 to 264V ac 5 to 125V dc	20.4 to 26.4V dc		85 to 264V ac	
Maximum Load Current	Refer to the following table	1.0A per point @ 55° C (131° F) 1.5A per point @ 30° C (86° F)		0.5A per point	
Minimum Load Current	10.0 mA	1 mA		10.0 mA	
Current per Controller	1440 VA	3A for L16BBB 6A for L32BBB		1440 VA	
Current per Common	8.0A	3A for L16BBB 6A for L32BBB		2.5A	
Maximum Off State Leakage Current	0 mA	1 mA		2 mA @ 132V ac 4.5 mA @ 264V ac	
Off to On Response	10 ms max.	0.1 ms		8.8 ms @ 60 Hz 10.6 ms @ 50 Hz	
On to Off Response	10 ms max.	1 ms		8.8 ms @ 60 Hz 10.6 ms @ 50 Hz	
Output Common Arrangement	16 I/O	32 I/O	16 I/O	32 I/O	32 I/O
	4 isolated 1 group of 2	2 isolated 1 group of 2 2 groups of 4	2 isolated relays 4 MOSFET: 1 group of 4	2 isolated relays 10 MOSFET: 1 group of 10	2 isolated relays 10 triac: 1 group of 2 2 groups of 4

Relay Contact Rating Table

Relay Contact Ratings	Maximum Volts	Amperes		Amperes Continuous	Voltamperes	
		Make	Break		Make	Break
	240V ac	7.5A	0.75A	2.5A	1800V ac	180V ac
	120V ac	15A	1.5A			
	125V dc	0.22A ^①		1.0A	28 VA	
	24V dc	1.2A ^①		2.0A	28 VA	

^① For DC voltage applications, the make/break ampere rating for relay contacts can be determined by dividing 28 VA by the applied DC voltage. For example, 28 VA ÷ 48V dc = 0.58A. For DC voltage applications less than 48V, the make/break ratings for relay contacts cannot exceed 2A. For DC voltage applications greater than 48V, the make/break ratings for relay contacts cannot exceed 1A.

Product Data

MicroLogix 1000 Programmable Controllers
and Hand-Held Programmer

Dimensions

Controller: 1761-	Length: mm (in.)	Depth: mm (in.) ^①	Height: mm (in.)
L16AWA	133 (5.24)	73 (2.87)	80 (3.15)
L16BWA	120 (4.72)		
L32AWA	200 (7.87)		
L32BWA			
L32AAA			
L16BBB	120 (4.72)	40 (1.57)	
L16BWB			
L32BBB	200 (7.87)		
L32BWB			

^① Add approximately 13 mm (0.51 in.) when using the 1761-CBL-PM02 or 1761-CBL-HM02 communication cables.

Use the recommended *minimum* spacing for the controller as shown below:

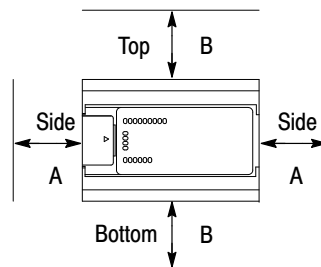

A. Greater than or equal to 50.8 mm (2 in).

B. Greater than or equal to 50.8 mm (2 in).

20142

The controller can only be mounted horizontally using either a DIN rail or mounting screws.

Hand-Held Programmer Specifications

The following tables summarize the specifications and dimensions for the Hand-Held Programmer.

General Specifications

Description	Specification: 1761-HHP-B30
Operating Power	83 mA @ 24V dc
Operating Temperature	0° C to 50° C (32° F to 122° F)
Storage Temperature	-20° C to 60° C (-4° F to 140° F)
Operating Humidity	5 to 95% noncondensing
Product Certification	UL listed, CSA certified, CE certified
Display Type	2 x 16 LCD
Keypad	30 Rubber/carbon Based Keys

Product Data

MicroLogix 1000 Programmable Controllers
and Hand-Held Programmer

Dimensions

Terminal: 1761-	Width: mm (in.)	Height: mm (in.)	Depth: mm (in.)
HHP-B30	95 (3.74)	170 (6.69)	35 (1.37)

MicroView Operator Interface Specifications

The following tables summarize the specifications and dimensions for the MicroView Operator Interface.

General Specifications

Description	Specification: 2707-MVH232
Input Voltage Range	24V dc ^①
Communication Port	RS-232
Operating Temperature	0° C to 45° C (32° F to 113° F)
Storage Temperature	-20° C to 70° C (-4° F to 158° F)
Operating Humidity	5 to 95% noncondensing
Shock	30g operating
Vibration	50g non-operating
Product Certification	FCC Part 15, Class A UL Class 1, Division 2 Hazardous Location, Groups A, B, C, D
Display Type	2 x 16 LCD,
Character Size	0.22 in. x 0.12 in. (5.56 mm x 2.96 mm)
Keypad	Tactile embossed, domed keys, sealed membrane

^① The MicroLogix 1000 Programmable Controllers provide 24V dc to the MicroView Operator Interface through the communication cable during runtime operation.

Dimensions

Operator Interface: 2707-	Width: mm (in.)	Height: mm (in.)	Depth: mm (in.)
MVH232	90.2 (3.55)	129.5 (5.1)	25.4 (1.0)

Product Data

MicroLogix 1000 Programmable Controllers
and Hand-Held Programmer

Notes

MicroLogix, SLC 500, MicroView, and DataDisc are trademarks of Allen-Bradley Company, Inc.
VERSA is a trademark of Nippon Electric Information Systems, Inc.
Gateway 2000 is a trademark of Gateway 2000, Inc.
IBM is a registered trademark of International Business Machines, Incorporated.



Allen-Bradley, a Rockwell Automation Business, has been helping its customers improve productivity and quality for more than 90 years. We design, manufacture and support a broad range of automation products worldwide. They include logic processors, power and motion control devices, operator interfaces, sensors and a variety of software. Rockwell is one of the world's leading technology companies.



Worldwide representation.

Argentina • Australia • Austria • Bahrain • Belgium • Brazil • Bulgaria • Canada • Chile • China, PRC • Colombia • Costa Rica • Croatia • Cyprus • Czech Republic • Denmark • Ecuador • Egypt • El Salvador • Finland • France • Germany • Greece • Guatemala • Honduras • Hong Kong • Hungary • Iceland • India • Indonesia • Ireland • Israel • Italy • Jamaica • Japan • Jordan • Korea • Kuwait • Lebanon • Malaysia • Mexico • Netherlands • New Zealand • Norway • Pakistan • Peru • Philippines • Poland • Portugal • Puerto Rico • Qatar • Romania • Russia-CIS • Saudi Arabia • Singapore • Slovakia • Slovenia • South Africa, Republic • Spain • Sweden • Switzerland • Taiwan • Thailand • Turkey • United Arab Emirates • United Kingdom • United States • Uruguay • Venezuela • Yugoslavia

Allen-Bradley Headquarters, 1201 South Second Street, Milwaukee, WI 53204 USA, Tel: (1) 414 382-2000 Fax: (1) 414 382-4444