

# **TourPro**

## **USER MANUAL**

### **PROFESSIONAL SHOW LIGHTING**

#### **LED**

#### **TX0610B**

**AC100~240V**

**50/60Hz**

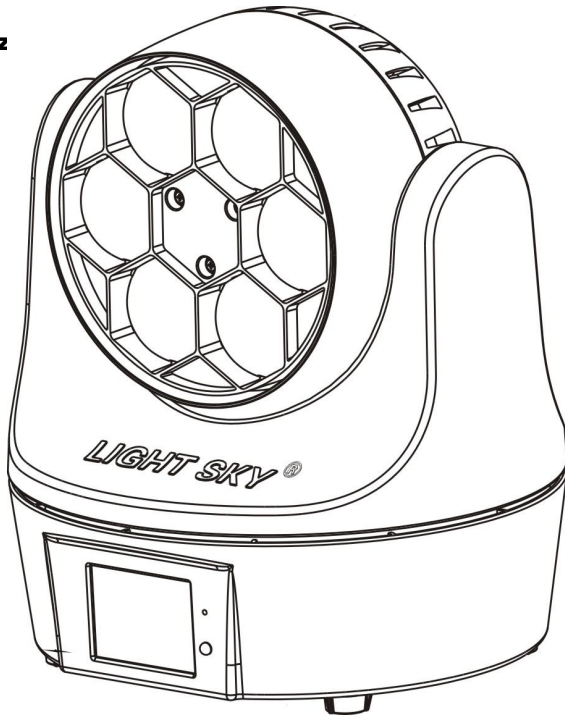

---

# CONTENTS

<b>1.</b>	<b>General information</b> .....	<b>2</b>
<b>2.</b>	<b>Safety instructions</b> .....	<b>3</b>
<b>3.</b>	<b>Trait and skill specifications</b> .....	<b>4</b>
<b>4.</b>	<b>Operation panel</b> .....	<b>6</b>
<b>5.</b>	<b>Dimensional drawings</b> .....	<b>6</b>
<b>6.</b>	<b>Photometric data</b> .....	<b>7</b>
<b>7.</b>	<b>Mounting and Installation</b> .....	<b>7</b>
<b>8.</b>	<b>Power supply and Signal connection</b> .....	<b>9</b>
<b>9.</b>	<b>Display menu</b> .....	<b>11</b>
<b>10.</b>	<b>DMX traits</b> .....	<b>18</b>
<b>11.</b>	<b>Circuit connecting diagram</b> .....	<b>22</b>
<b>12.</b>	<b>Trouble dispose</b> .....	<b>23</b>
<b>13.</b>	<b>Cleaning and Maintenance</b> .....	<b>24</b>
<b>14.</b>	<b>Duty exonerative and Copyright protection</b> .....	<b>24</b>

---

# 1. GENERAL INFORMATION

**INTRODUCTION:** Congratulations, you have just purchased one of the most innovative and reliable LED fixtures on the market today. Our company has been designed to perform reliably for years when the guidelines in this booklet are followed. Please read and understand the instructions in this manual carefully and thoroughly before attempting to operate this unit. These instructions contain important information regarding safety during use and maintenance.

**Notice:** As part of our ongoing commitment to continuous products update, company will keep the right to improve this products, the information in this menu may be changed in the future, the company reserve the right to change the data without any advises.

**UNPACKING:** Thank you for purchasing our company products. Every product has been thoroughly tested and has been shipped in perfect operating condition. Carefully check the shipping carton for damage that may have occurred during shipping. If the carton appears to be damaged, carefully inspect your fixture for damage and be sure all accessories necessary to operate the fixture have arrived intact. In the event damage has been found or parts are missing, please contact our customer support team for further instructions. Inside the box you should find: the fixture, a DMX XLR cable, a power cable, and this user manual.

Please do not discard the shipping carton in the trash. Please recycle whenever possible.

---

## 2. SAFETY INSTRUCTIONS

**Notice:** To guarantee proper and consistent operation, it is important to follow the guidelines in this manual. Our company will not accept responsibility for damages resulting from the misuse of this fixture due to the disregard of the information printed in this manual.

- 1. In order to ensure the light could operate normally, the ambient temperature couldn't be higher than 38°C and no lower than -2°C.
- 2. Under normal condition, the highest sectional surface temperature may be up to 60 °C.
- 3. These projectors are designed depends on the electric shock protection, the projector should be connected with the power supply system which connected ground enough. The projector's ground cable should be connected with the ground cable of the power supply system as well. The ground mark of the light metal cover should be connecting with the installation bricked steadily.
- 4. Connecting the main power supply should be done by the professional person.
- 5. Please check the voltage, frequency data of power supply system is suitable for the mentioned on the projector. Please do avoid the different voltage between them and burn the projector.
- 6. Do not attempt to operate this fixture if the power cord has become damaged or frayed.
- 7. Never open this fixture while in use.
- 8. Never look directly into the light source. You risk injury to your retina, which may induce blindness.
- 9. Please be aware that damages caused by modifications to the device are not subject to warranty.

---

### **3. PERFORMANCE TRAIT AND SKILL SPECIFICATIONS**

- ◎ Voltage: AC100~240V 50/60Hz.
- ◎ Power: 91W.
- ◎ LED chip: 10W, RGBW 4 in 1 LED chip.
- ◎ LED QTY: 6PCS.
- ◎ LED life: 50000H.
- ◎ Lens degree: standard: 1.5°.
- ◎ Beam angle: Minimum 6°, Maximum 51°
- ◎ Color: RGBW macro color system.
- ◎ Strobe: 1-30 times/ second electronic strobe and random strobe.
- ◎ Dimmer : 65536 class dimmer.
- ◎ Pan/Tilt : Pan : 540° times /1.5 seconds Tilt: 180°/0.5 seconds.
- ◎ Control Mode: DMX512, RDM, Stand-alone mode ,Voice Control mode , Mater-Slave mode , Wireless DMX512.
- ◎ Channel: Standard Channel : 11 , Extend Channel : 17.
- ◎ Display Menu:
  1. 2.4 inches TFT touch screen, Chinese and English two version language.
  - 2, Display board can record device's using time , show device's temperature, channel data and software version .
  - 3, Edit the procedure
- ◎ Other feature :
  1. Extend IP address function , each IP address maximum can set 64 ID.

---

2.Support DMX signal priority identification, when lose the signal it would be turn into Black , default scene , Automatic function etc according to your set.

3.Remote control function: control the procedure, speed etc function by the remote controller when the product under the condition without signal.

4.software upgrade : upgrade software by XRL cable.

© Outlooking: adopt ABS anti-fire plastic.

© Carton size : 270×260×350MM.

© N.W.: 3.8KG G.W.: 5.7KG

© Light size:φ226×268MM

## 4. OPERATION PANEL

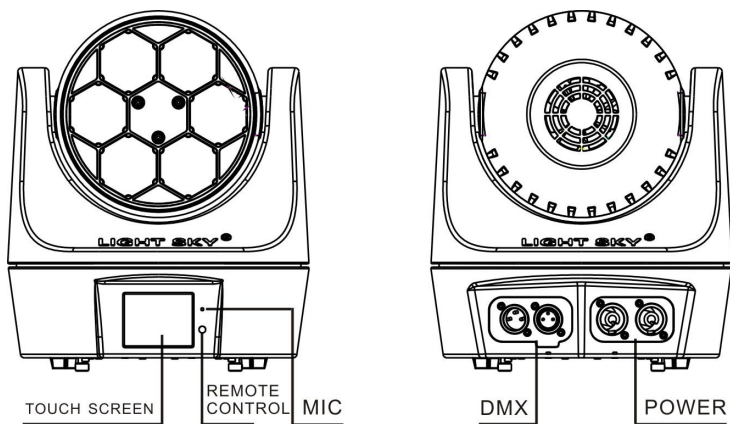

## 5. DIMENSIONAL DRAWINGS

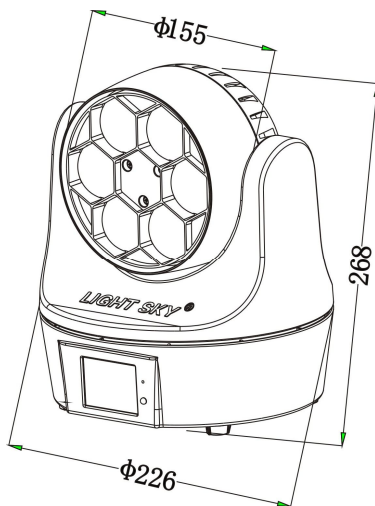

## 6. PHOTOMETRIC DATA

	Lux			
R	3160	1190	615	272
G	10200	4860	2900	2140
B	1080	850	392	95.5
RGBW	10600	5050	2900	1770

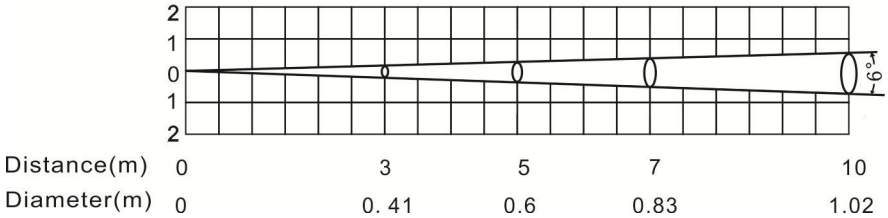

## 7. MOUNTING AND INSTALLATION

### Cautions:

For added protection mount the fixtures in areas outside walking paths, seating areas, and away from areas where unauthorized personnel might reach the fixture. Before mounting the fixture to any surface, make sure that the installation area can hold a minimum point load of 10 times the device's weight. Fixture installation must always be secured with a secondary safety attachment, such as an appropriate safety cable. To avoid injury, never stand directly below the device when mounting, removing, or servicing the fixture.

### Mounting points:

Overhead mounting requires extensive experience, including amongst others calculating working load limits, a fine knowledge of the installation material being used, and periodic safety inspection of all installation material and the fixture. If you lack these qualifications, do not attempt the installation yourself. Improper installation can result in bodily injury. Be sure to complete all rigging and installation procedures before connecting the main power cord to the appropriate wall outlet.





**CAUTION!**

**Be sure a qualified electrician performs all electrical connections.**

**Mounting**

Our company is fully operational in any mounting position, hanging upside-down, side mounted, or set on a flat level surface, etc. Be sure this fixture is kept at least 0.5m (about 1.6feet) away from any flammable materials (decoration etc.).

When clamp mounting; always use and install the supplied safety cable as an added safety measure to prevent accidental damage in the event of a clamp failure. See the image below.

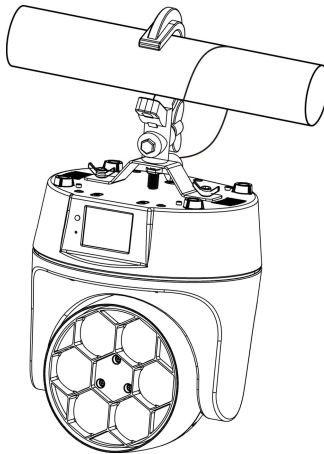

## 8. POWER SUPPLY AND SIGNAL CONNECTION

### 1. Power supply

Use the professional plug to connect the projector and main power supply. Please pay attention to the voltage, frequency the same as the mentioned on the projector. Suggest each light has separately switched of the power supply so that could turn on or turn off each projector desultorily.

### 2. Signal connection

Please use the round 3/5-pin XLR plugs & sockets offered by menu facture to connect the first projector's output to the second projector' input and connect the second projector's output to the third device's input. And in the same way for the rest, eventually connect the last device's output, all the devices are together as the following figure.

The devices' control signal output or input by using the 3/5-pin XLR pug and socket. If need to long then the communication cable, please make sure the both side of 3/5-pin plug is one to one. (one to one, two to two, three to three). Otherwise, the communication cable will be interrupted.

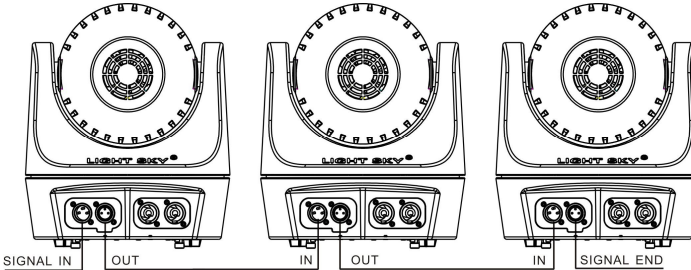

The communicate cable is 2-pin shielded cable  $75\Omega$

Resistance with each core is at least a 0.5mm diameter. (Caution: All the inside leading wire of 3/5-pin XLR plug couldn't touch each other or plinth).

Recommend to use the DMX signal terminator for the installation to avoid the electronic noise damage the digital control signal. Simply speaking, DMX terminator is an XLR connector with a  $120\Omega$  1/2w

resistor connected across pin 2 and 3. Which is then plugged into the output socket on the last projector in the chain. Refer to the connection as above: (Picture ). We suggest using the DMX signal distributor when the distance of the lights over 15meter, In case of effect the light communication because of the signal feeble.

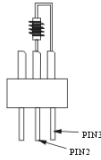

### 3. Light power connection:

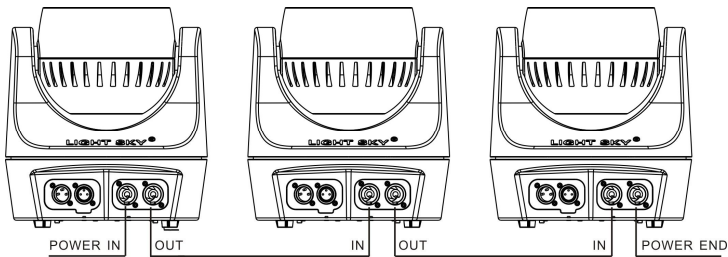

The L terminal is connected with the brown line

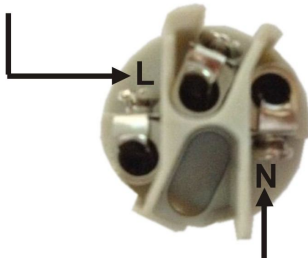

The N terminal is connected with the blue line

the items can't be more than 6pcs under series connection.

After doing the above operation and making sure all the devices had been installed with natural operate, press the power switch to check whether everything is working normally.

## 9. DISPLAY MENU

I Menu	II Menu	III Menu	Remark
SETTING	DMX Address	001-512	
	Fixture ID	000-064	
	Channel mode	Standard (11CH)	Default
		Extended (17CH)	
	DMX input mode	Wired input	Default
		Wireless input	
		Reset wireless	
	DMX function	Hold	
		Black	
		D. scene	
		Program 1	
		Program 2	
		Program 3	
		Program 4	
		Program 5	
		Program 6	
		Program 7	
	Slave-Master	Slave mode	
		Master mode	
	Music control	Close	
		Open	
	Exit		

I Menu	II Menu	III Menu	Remark	
INFO	Fixture times	Power on time ****H		
		Lamp on time ****H		
	Fixture temperatures	LAMP_TEM ***°C		
	RDM UID	3888: *****)		
	DMX live	1. Dimmer	0-255	
		2. Dimmer fine	0-255	
		3. Shutter	0-255	
		4. Red	0-255	
		5. Green	0-255	
		6. Blue	0-255	
		7. White	0-255	
		8. Macro colour	0-255	
		9. Pan	0-255	
		10. Pan fine	0-255	
		11. Tilt	0-255	
		12. Tilt fine	0-255	
		13. Rota. lens	0-255	
		14. Rota. Sp	0-255	
		15. Fixture contro	0-255	
		16. Calibration	0-255	
17. Slave ID		0-255		
Version info	LED_XY_SOFT:V*. **			
	LED_DPY_SOFT:V*. **			
Exit				

I Menu	II Menu	III Menu	IV Menu	Remark
PERSON	Pan/Tilt	P/T swap	OFF	Default
			ON	
		Pan invert	OFF	Default
			ON	
		Tilt invert	OFF	Default
			ON	
		Exit		
		DMX reset	ON	
	OFF			
	Reset	System reset		
		Exit		
	Quick closedown	Open		
		Close		
	P/T angle limit	Close		
		Open		
	Program on/off	Close		
		Open		
	Set p/t angle	Pan start		
		Pan end		
		Tilt start		
		Tilt end		
		Exit		

I Menu	II Menu	III Menu	IV Menu	Remark
PERSON	Display	Display language	English (英文)	Default
			Chinese (中文)	
		Display sleep	Light always	
			2 minutes	Default
			4 minutes	
			6 minutes	
		Display intensity	10-100	Default :50
		Display rotation	Normal	Default
			Rotate 180	
		TFT calibration		
		Exit		
	Exit			

I Menu	II Menu	III Menu	Remark
MANUAL	1. Dimmer	0-255	
	2. Dimmer fin	0-255	
	3. Shutter	0-255	
	4. Red	0-255	
	5.Green	0-255	
	6. Blue	0-255	
	7. White	0-255	
	8.Macro colo	0-255	
	9. Pan	0-255	
	10. Pan fine	0-255	
	11. Tilt	0-255	
	12. Tilt fine	0-255	
	13.Rota.lens	0-255	
	14. Rota.Sp	0-255	
	15. Fixture c	0-255	
	16. Calibrati	0-255	
	17. Slave ID	0-255	
	Exit		



I Menu	II Menu	III Menu	IV Menu
PROGRAM	Edit program	Edit program 1	Scene 0-100
			1.Dimmer 0-255
			2.Dimmer fin 0-255
			3.Shutter 0-255
			4.Red 0-255
			5.Green 0-255
			6.Blue 0-255
			7.White 0-255
			8.Macro colo 0-255
			9.Pan 0-255
			10.Pan fine 0-255
			11.Tilt 0-255
			12.Tilt fine 0-255
			13.Rota.lens 0-255
			14.Rota.Sp 0-255
			15.Fixture c 0-255
			16.Calibrati 0-255
			17.Slave ID 0-255
		Save scene	
		Exit	
		Edit program 2	Same as Edit program1
		Edit program 3	Same as Edit program1
		Edit program 4	Same as Edit program1
		Edit program 5	Same as Edit program1
		Edit program 6	Same as Edit program1
		Edit program 7	Same as Edit program1
		Edit program 8	Same as Edit program1
Exit			

I Menu	II Menu	III Menu	IVMenu
PROGRAM	Set program	Set program 1	Start step 0-100
			End step 0-100
			Step time0-255
			Save
			Exit
		Set program 2	Same as Set program 1
		Set program 3	Same as Set program 1
		Set program 4	Same as Set program 1
		Set program 5	Same as Set program 1
		Set program 6	Same as Set program 1
		Set program 7	Same as Set program 1
	Set program 8	Same as Set program 1	
	Exit		
	Run	Running program.	
Fixed scene	Scene 001-100		
Exit			
SERVICE	Error list		
	Adjust	Pan	±5.00%
		Tilt	±5.00%
		Rota.lens	±5.00%
		Exit	
	Factory	Default	****
		Adjust default	****
		Time clean	****
		Developer	****
		Machine set	****
		Exit	
Updata	****		
Exit			

## 10. DMX TRAITS

Channel	DMX values	%	Effect
1. Dimmer	0-255	0-100	
2. Dimmer fine	0-255	0-100	
3. Shutter	0-9	0-3	Unused range
	10-49	4-19	Light→dark, slow→fast
	50-89	20-34	Dark→light, slow→fast
	90-119	35-46	Dark→light→dark, slow→fast
	120-179	47-70	Random fast→slow strobe
	180-250	71-98	In-phase, slow→fast
	250-255	99-100	Unused range
4. Red	0-255	0-100	
5. Green	0-255	0-100	
6. Blue	0-255	0-100	
7. White	0-255	0-100	
8. Macro colour	0-1	0-1	Unused range
	2-254	1-99	Shadow
	255	100	Unused range
9. Pan	0-255	0-100	
10. Pan fine	0-255	0-100	
11. Tilt	0-255	0-100	
12. Tilt fine	0-255	0-100	
13. Rota.lens	0-127	0-49	
	128-135	50-52	
	136-231	53-90	
	232-255	91-100	

Channel	DMX values	%	Effect
14. Rota. Sp	0-255		0-100
15. Fixture control	0-9	0-3	Unused range
	10-14	4-5	Complete reset
	15-19	5-7	Open
	20-24	7-9	Close
	25-29	10-11	Quick open
	30-34	12-13	Quick close
	35-239	14-93	Unused range
	240-244	94-95	Pan
	245-249	96-97	Tilt
250-255	98-100	Unused range	
16. Calibration	0-255	0-100	
17. Slave ID	0-2	0	All IDs are efficient lighting its own ID to 0, the channel set to any value is valid
	3-5	1-2	ID: 1 effective
	6-8	2-3	ID: 2 effective
	...	...	
	192-194	75-76	ID: 64 effective
	195-197	76-77	ID is(2*n)+1 effective,(n=0-31) 1、 3、 5、 7、 9...63
	198-200	77-78	ID is(2*n)+2 effective,(n=0-31) 2、 4、 6、 8、 10...64
	201-203	78-79	ID is(3*n)+1 effective,(n=0-21) 1、 4、 7、 10、 13...64

Channel	DMX values	%	Effect
17. Slave ID	204-206	80-81	ID is(3*n)+2 effective,(n=0-20) 2、5、8、11、14…62
	207-209	81-82	ID is(3*n)+3 effective,(n=0-20) 3、6、9、12、15…63
	210-212	82-83	ID is(4*n)+1 effective,(n=0-15) 1、5、9、13、17…61
	213-215	83-84	ID is(4*n)+2 effective,(n=0-15) 2、6、10、14、18…62
	216-218	84-85	ID is(4*n)+3 effective,(n=0-15) 3、7、11、15、19…63
	219-221	85-86	ID is(4*n)+4 effective,(n=0-15) 4、8、12、16、20…64
	222-224	87-88	ID is(5*n)+1 effective,(n=0-12) 1、6、11、16、21…61
	225-227	88-89	ID is(5*n)+2 effective,(n=0-12) 2、7、12、17、22…62
	228-230	89-90	ID is(5*n)+3 effective,(n=0-12) 3、8、13、18、23…63
	231-233	90-91	ID is(5*n)+4 effective,(n=0-12) 4、9、14、19、24…64
	234-236	91-92	ID is(5*n)+5 effective,(n=0-11) 5、10、15、20、25…60
	237-239	93-94	ID is(6*n)+1 effective,(n=0-10) 1、7、13、19、25…61

Channel	DMX values	%	Effect
17. Slave ID	240-242	94-95	ID is(6*n)+2 effective,(n=0-10) 2、 8、 14、 20、 26...62
	243-245	95-96	ID is(6*n)+3 effective,(n=0-10) 3、 9、 15、 21、 27...63
	246-248	96-97	ID is(6*n)+4 effective,(n=0-10) 4、 10、 16、 22、 28...64
	249-251	97-98	ID is(6*n)+5 effective,(n=0-9) 5、 11、 17、 23、 29...59
	252-254	98-99	ID is(6*n)+6 effective,(n=0-9) 6、 12、 18、 24、 30...60
	255	100	All IDs are valid

### Standard (11CH)

1.Dimmer	4. Green	7. Pan	10. Rota.Speed
2.Shutter	5. Blue	8. Tilt	11.Fixture control
3.Red	6. White	9. Rota.lens	

### Extended (17CH)

1.Dimmer	6. Blue	11.Tilt	16. Calibration
2.Dimmer fine	7. White	12. Tilt fine	17. Slave ID
3.Shutter	8.Macro colour	13. Rota.lens	
4. Red	9. Pan	14.Rota.Speed	
5. Green	10. Pan fine	15.Fixture control	

# 11. CIRCUIT CONNECTING DIAGRAM

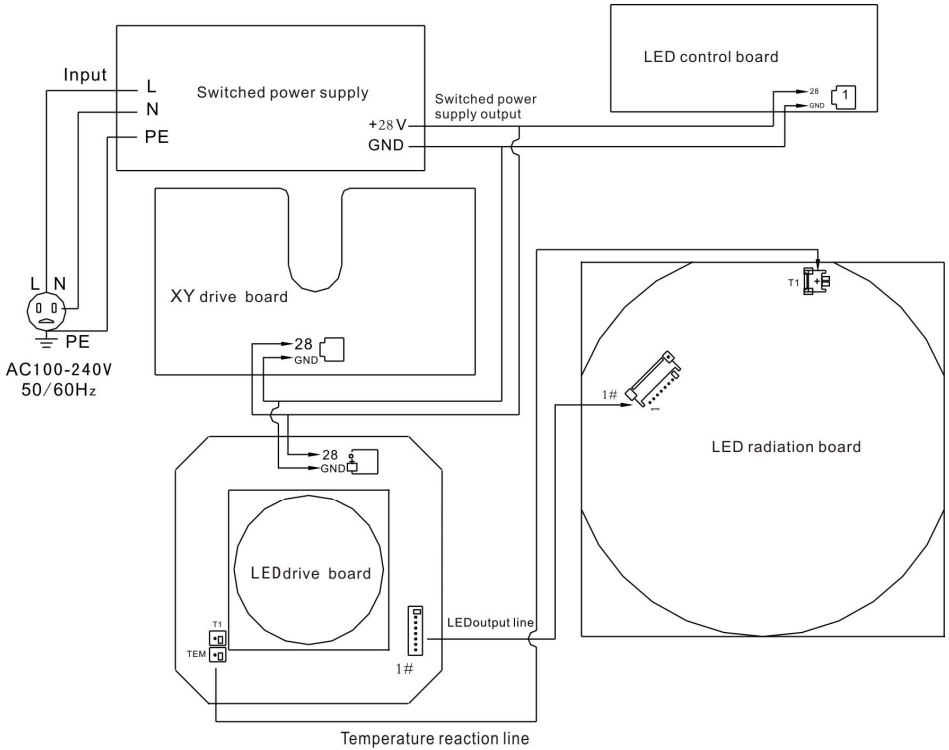

---

## **12. TROUBLE DISPOSE**

It is recommended some solution for some normal trouble shooting. Any inextricability problems should always be handling by the professional person. Disconnect the power supply before maintenance the light.

●LED off:

1. Please check if install the suitable voltage
2. Please check whether the led will reach the end of their life can explode; please replace a same description led.
3. Please check if the power supply is enough.
4. Please check whether the DMX 512 controller pass the "turn on" order.

●Though the light is lighting, but it couldn't accept the control order:

1. Please check the start code address and the function option are correct.
2. Please check whether the communicate control cable is on good connection or the cable is too long or interrupt.
3. Please check the control system is not valid, check the signal amplifier of chain connected is valid.
4. Please check whether the communicate cable is too long or the other equipment is mutually conjugate.
5. Please arrange the wire well, shorter the signal cable, put the high voltage cable and low voltage cable separately.
6. Add the signal amplify isolator.
7. Signal cable is used the excellent screening doublet (Resistance 75 OHM)
8. The end of the light end and the end resistance.

●The light can't move:

1. Please check if the power supply is suitable for the light voltage data.
2. Please check the fuse of input voltage is defective.
3. Please check the light if they are deformation, inside parts is broken, become wet etc will lead the loose contact.



---

## **13. CLEANING AND MAINTENANCE**

- 1. In order to ensure the projector could work normally. It should be kept clean always .The lens should also be regularly cleaned to maintain an optimum light output. Do not use any type of solvent on lens. It will damage the projector.
- 2. Suggestion: The continue usage of the light don't exceed 4 hours. Or it will shorter the usage of the lamp. Please use the alternative operation to solve this problem.
- 3. Please disconnect the power supply when begin to maintenance take down the light. Please let the parts cool down 10 minute at least then begin to install.
- 4. Please inspect the lens or other moving parts timing and keep them clear and static. If find anything damaged or looseness must change a lamp or fix the lamp in order to avoid the accident.

### **CAUTION!**

Disconnect from mains before starting maintenance operation.

## **14.DUTY EXONERATIVE AND COPYRIGHT PROTECTION**

- © Any products broken that didn't according to the instruction is not guarantee to keep it in good repair.
- © The commentary for all the instruction belongs to the supplier in final.
- © No authorize can't copy.