



Loving music

Statement

Turntable

User Manual



The Statement Turntable
Every market needs a leader

Made in Germany

Hi-Fi Components **Clearaudio electronic** GmbH

Spardorfer Str. 150 | D-91054 Erlangen | Tel. +49 9131 40300100 | FAX +49 9131 51683
www.clearaudio.de | www.analogshop.de | info@clearaudio.de / Clearaudio copyright © 2008

Version-November 2013

Dear Statement owner,

Congratulations on your purchase of the *Statement* turntable.

You have purchased a state-of-the-art turntable, the *Statement*, a world class product from **Clearaudio** electronic GmbH.

The special resonance-optimised construction, the external motor-unit and the patented **Clearaudio** - CMB-bearing-technology guarantees absolute speed stability, pure pleasure in listening and reproduction absolutely faithful to the original.

Thank you very much your confidence.

Please read this user manual carefully to ensure that your *Statement* turntable is correctly installed ready to take you to a new dimension of music reproduction.

We hope you will enjoy your new **Clearaudio** *Statement* turntable.

Clearaudio electronic GmbH

Please read the warning before connecting your *Statement* turntable to the mains supply.

WARNING

Don't expose your Statement-turntable to rain or excessive humidity.
Don't handle the mains lead with wet hands.
Don't place or insert anything into the equipment or through ventilation holes.
No naked flame sources, such as lighted candles, should be placed on the equipment.

CE-MARKING

CE The **Clearaudio** *Statement* meets the regulations concerning electromagnetic disturbance (EMC) and low-voltage appliances.

COPYRIGHT

Recording and reproduction of any sound material may require the consent of the creator.

Please acknowledge the information given in the

- Copyright Act 1956,
- Dramatic and Musical Performers Act 1958,
- Performers Protection Acts 1963 and 1072,
- Any more recent legal regulations.

Contents

1. Packing content	4
2. Construction overview	6
3. Set up and operation	7
4. Motor adjustment	16
5. Special directions	17
6. Service	18
7. Technical data	19
Warranty information	20

1. Packing content

The *Statement* turntable is packed and delivered on either a Euro pallet or two half size Euro pallets. The Packing is specially made for the *Statement* - turntable and should be retained for any repacking.

Please note:

The *Statement* - turntable is very heavy and will require at least two people to unpack and set up.

Attention / Warning :

IMPORTANT!

Before it is fully assembled there are strong magnetic fields around the main bearing, these could interfere with heart pacemakers and so the *Statement* should not be set up by anyone with a pacemaker.

The *Statement* turntable is extremely heavy and should not be assembled by anyone with back problems.

The two wooden boxes contain the turntable stand and the pendulum weights, as well as five (5) separately packed cartons containing all other parts (e.g. massive metal cross, acrylic chassis, bearings etc).

Please check the accessories contents according to the following list before you set up the turntable.

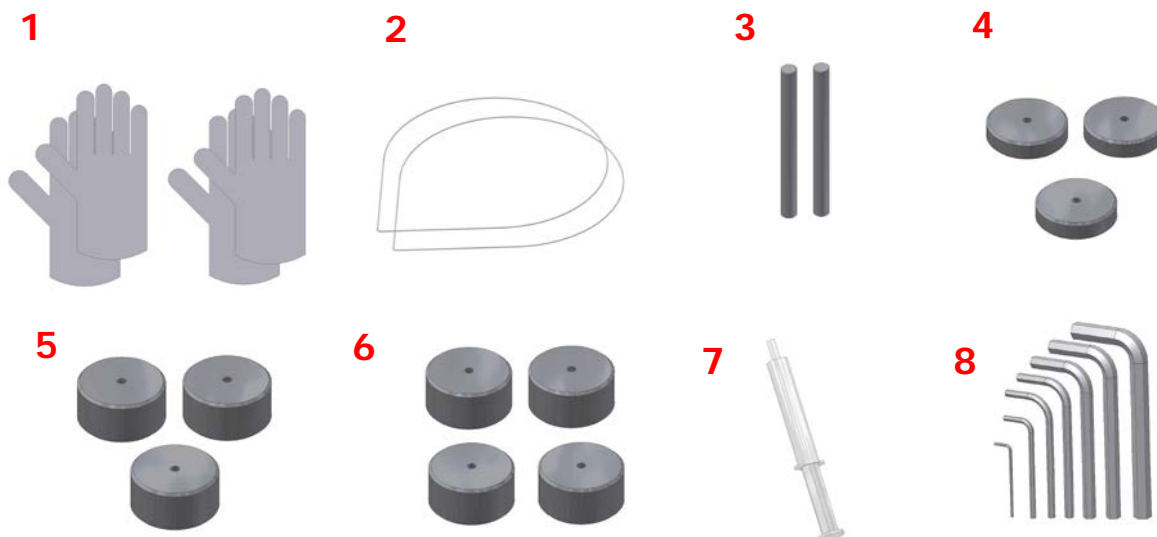

1.	Two pairs of white gloves	5.	Three bases as counter weights (40 mm)
2.	Two belts	6.	Four bases as flat pads
3.	Tool for adjustment of stainless steel discs (pendulum weight)	7.	Polishing paste
4.	Three bases as counter weights (20 mm)	8.	A set of hex key wrenches

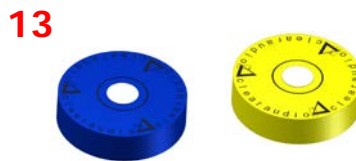

9.	Bearing oil	13.	Bubble level gauges
10.	Acrylic cleaner	14.	Not shown: Two wooden blocks
11.	Aluminium screw driver	15.	Not Shown: User manual
12	Statement clamp	16.	Not shown: Warranty card, Clearaudio certificate card (QCQ)

2. Construction overview

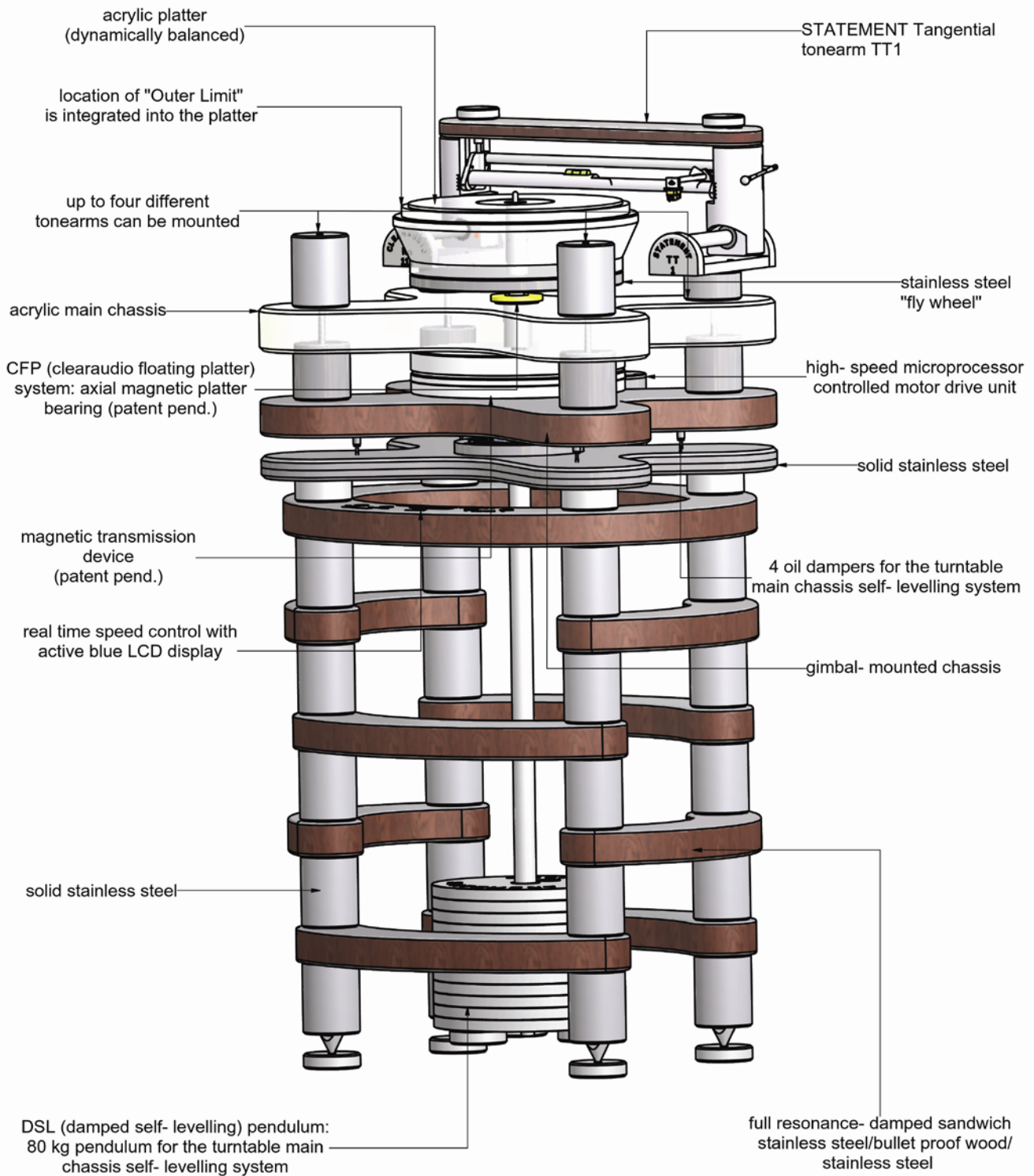

3. Set up and operation

1. Select the position in which you will use the *Statement* turntable. Place the *Statement* turntable base in this position on the four supplied feet.



Pic. 1: Placing the Statement



Pic. 2: Placing the Statement

2. Place the two wooden blocks beneath the *Statement* base as shown.

IMPORTANT!

Being careful not to damage the bearing spindle on top of the pendulum shaft, assemble the pendulum, starting by sliding a solid metal disc over the pendulum shaft so that it rests on the wooden blocks. Be sure to place a felt mat between each metal disc, building the pendulum with three solid discs at the bottom, then six half-cut-away discs, then two more solid discs, finally adding the solid disc engraved with the words **Clearaudio Statement**.

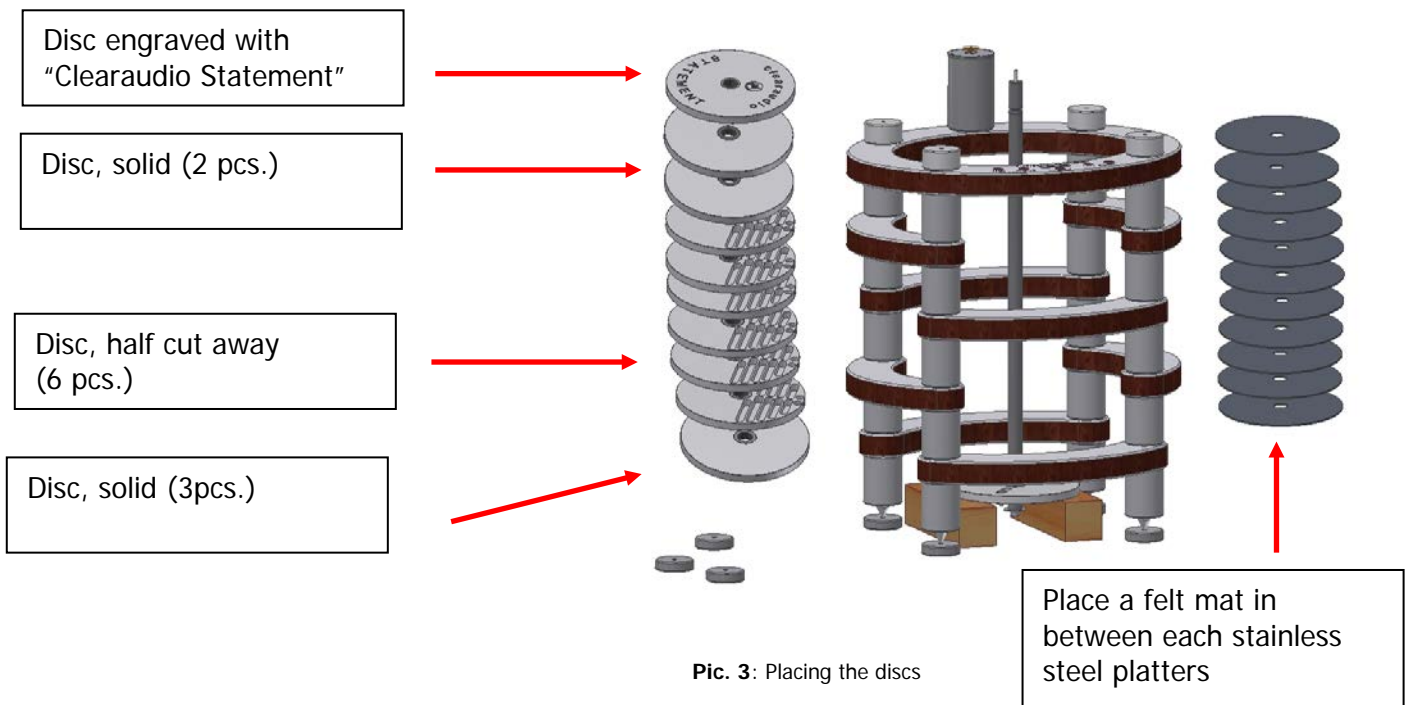

Please note:

If you are using the *Statement TT1* tangential tonearm, position the half-cut-away discs with the cut-away section at the rear of the turntable.

3.

Place the four cork damping plates on top of the four corner pillars.

Place 4 pcs. damping plates if not assembled already from the factory

Again, **being careful** not to damage the bearing spindle on top of the pendulum shaft, lower the stainless steel cross frame over the pendulum shaft so that it rests on the four cork damping plates.

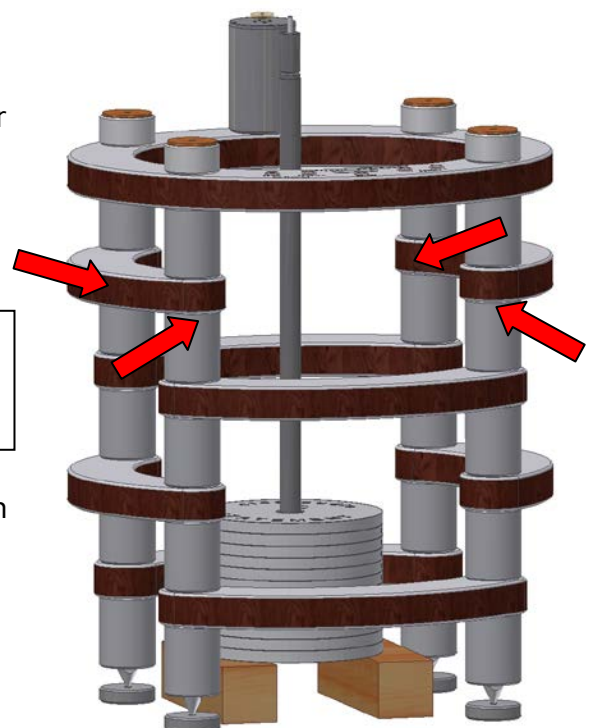

5.
Set the cross shaped massive metal part through the spindle onto the four cork



Pic. 5: Placing the metal part



Pic. 5.1: Placing the metal part

6.
Tighten the bearing to the shaft by tightening the screws in the bearing collar (8x).

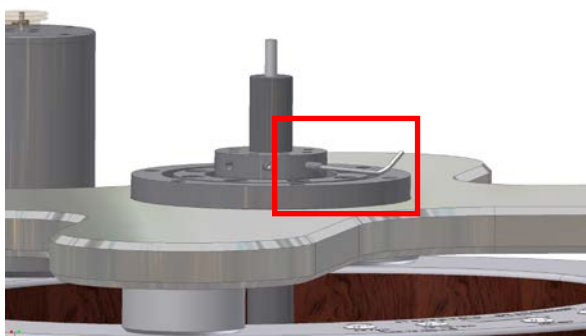

Pic. 6: Tighten the bearing



7.

Lift the pendulum shaft to align the V-shaped groove in the pendulum shaft with the locking screws in the gimbal bearing. Lock the gimbal bearing to the pendulum shaft by fully tightening the eight screws so that they locate in the groove of the pendulum shaft.

IMPORTANT!

Carefully lift the whole upper section, raising the pendulum off of the wooden blocks.

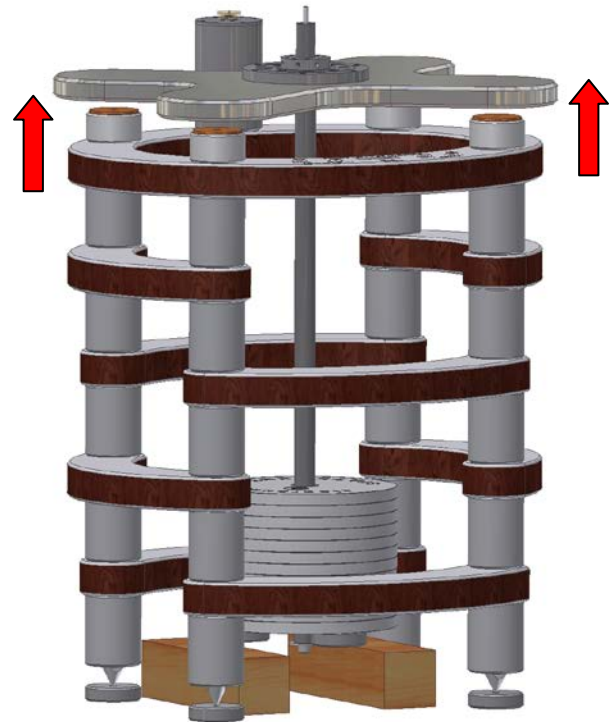

Pic. 7: Lifting the upper part

8.

Remove the wooden blocks from beneath the turntable and carefully lower the upper section back onto the four cork damping plates.

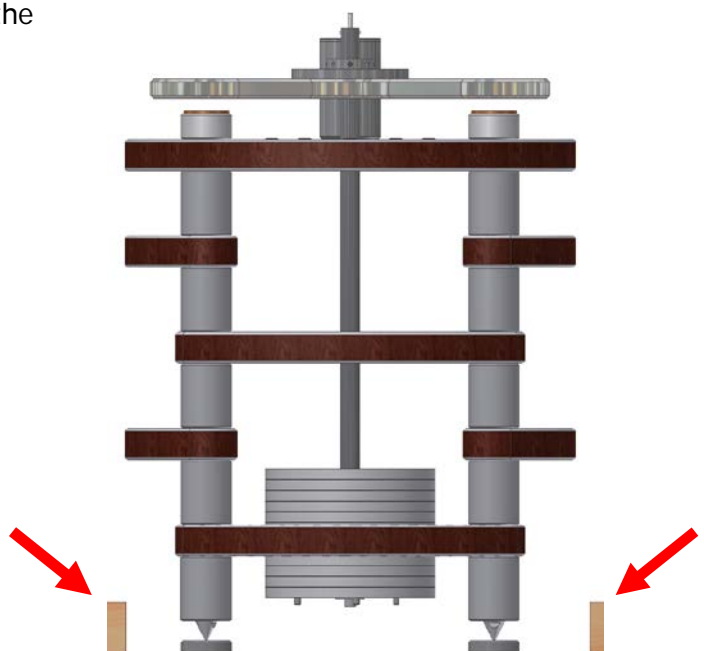

Pic. 8: Removing the wooden spacers

9. Lock the floating chassis to the pendulum shaft by fully tightening the eight screws.

IMPORTANT!

Being careful not to damage the bearing spindle on top of the pendulum shaft, lower the main floating chassis over the top of the pendulum shaft.



Pic. 9: Removing the wooden spacers

10. Apply 3 to 4 drops of the **Clearaudio** Synthetic Bearing Oil (also available at www.analogshop.de Art . No. AC068) to the bearing spindle.

Please apply 3 to 4 drops to the bearing spindle

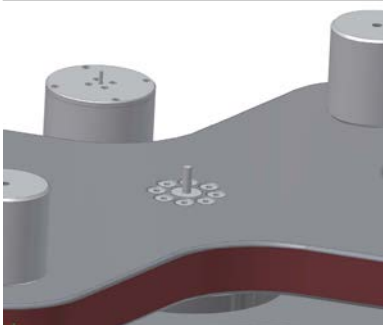

Pic. 10: Tighten the bearing screws

Lock the 8 screws

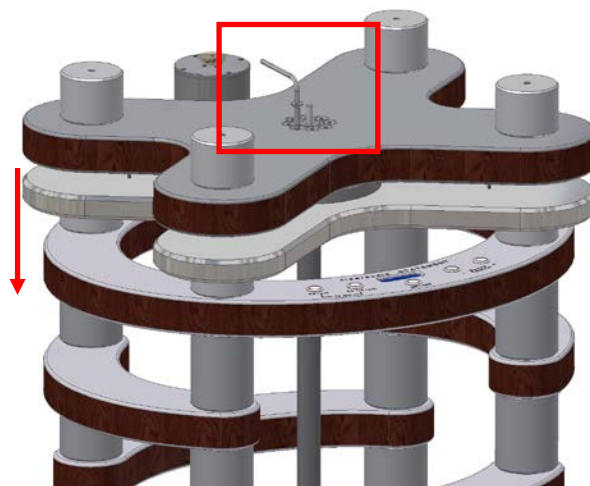

11.

Place the lower drive bearing housing over the bearing spindle.

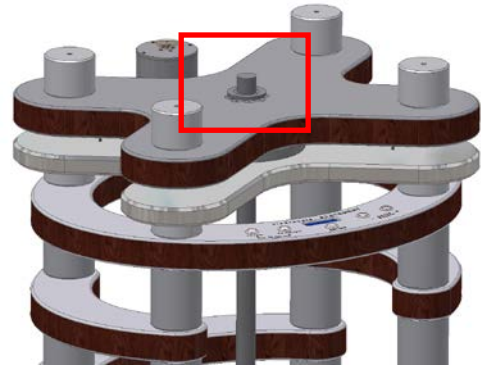

Pic. 11: Placing the lower bearing house

12.

Place the lower magnetic drive platter over the bearing housing making sure that the ring of magnets faces upwards.

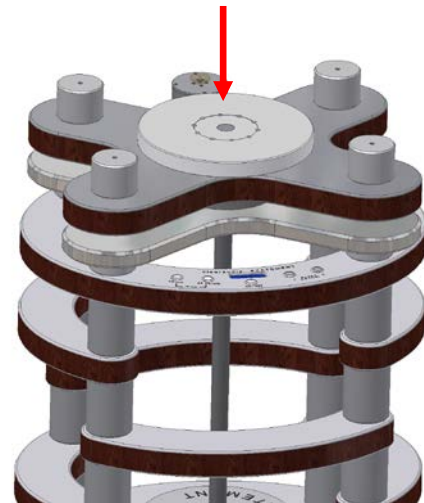

Pic. 12: Placing the lower magnetic drive platter

13.

For the next step, please apply 3 to 4 drops of the **Clearaudio** Synthetic Bearing Oil also onto the main bearing spindle.

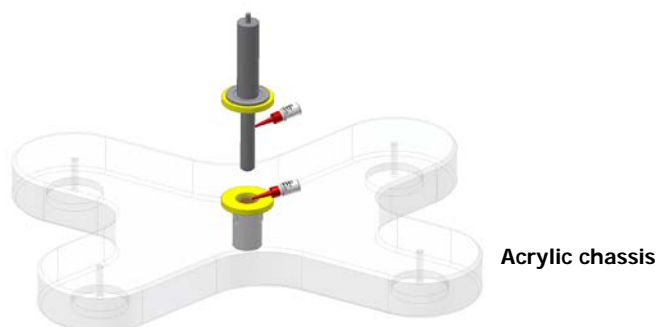

Pic. 13: Oiling the main bearing spindle

14.

Making sure that the circular cut-outs in the corners of the acrylic chassis are on the underside.
Carefully (!) insert the bearing spindle into the bearing sleeve in the acrylic chassis.

IMPORTANT!

Be careful not to allow the magnets to snatch the bearing as you insert it.

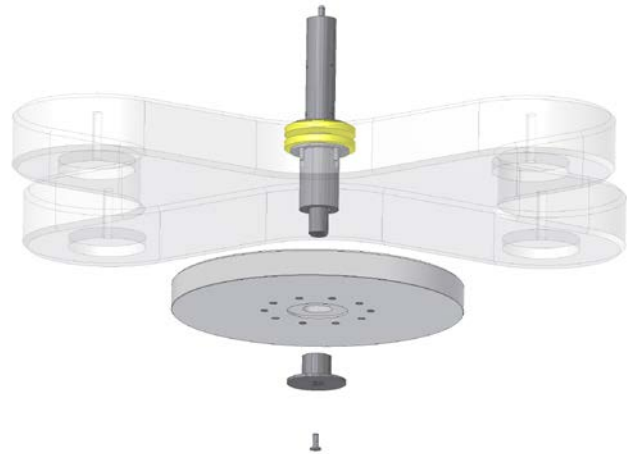

Pic. 14: To insert the bearing spindle into the bearing sleeve

15.

Attach the upper drive platter to the bottom of the main bearing spindle by screwing the bottom cap very tightly to the bottom of the main bearing.
Make sure that the ring of magnets faces down.

IMPORTANT!

Gently push the upper magnetic drive platter upwards against the acrylic chassis to ensure that the platter fully sits in the bearing.

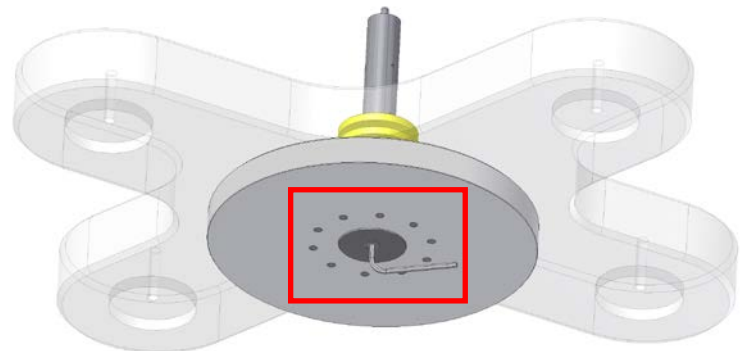

Pic. 15: To attach the upper drive platter to the bottom of the main bearing spindle

16.

Lower the acrylic chassis onto the four pillars at the corners of the floating chassis so that the circular cut-outs sit over the pillars.



Pic. 16: To lower the acrylic chassis

17.

Firmly screw the four stainless steel arm bases through the acrylic chassis into the four pillars of the floating chassis.

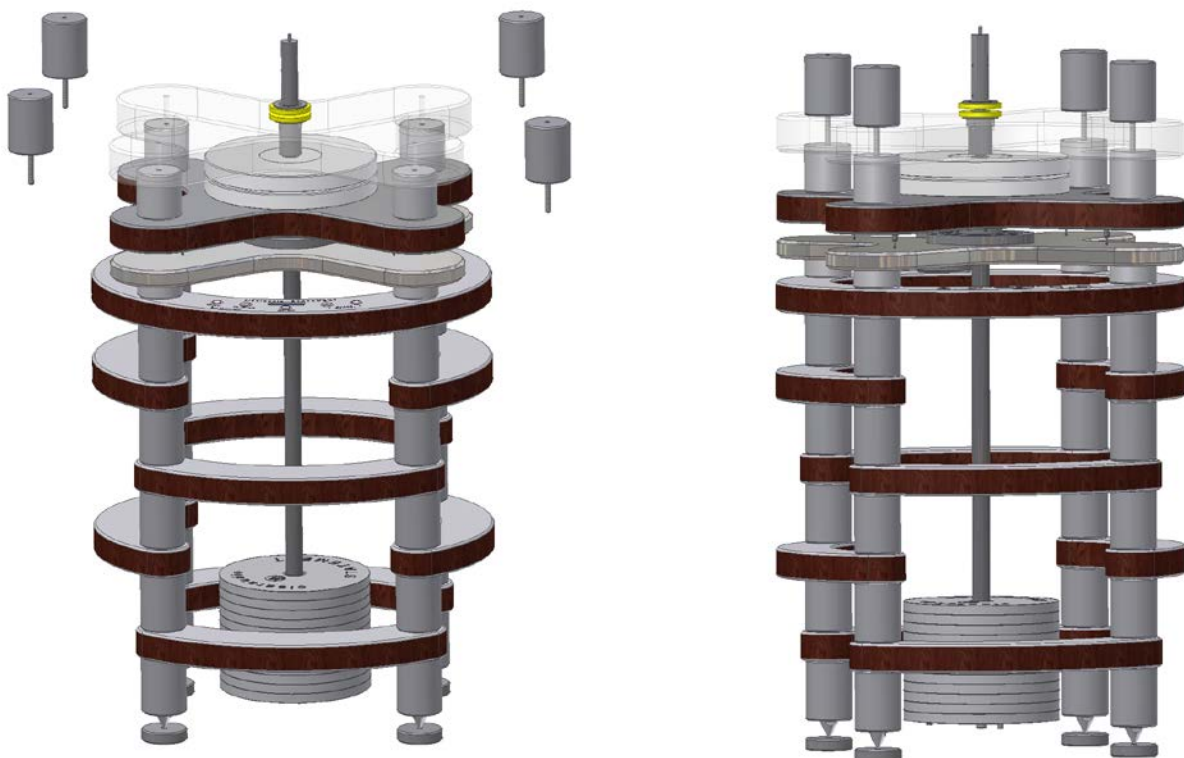

Pic. 17: Setting the arm bases

18.
Lower first the metal flywheel over the main bearing.

In the next step lower the main platter on top of the metal flywheel, making sure that the dot on the top of the bearing and the platter are aligned.



Pic. 18: Setting the platters



Pic. 19: Finished set up

4. Motor adjustment

1.

Push the motor pulley over the motor spindle and lock in place by gently tightening the three screws in the side of the pulley.

(If not already factory adjusted)



Pic. 20: Setting the motor pulley

2.

Place the drive belt first around the lower drive platter and then around the motor pulley.

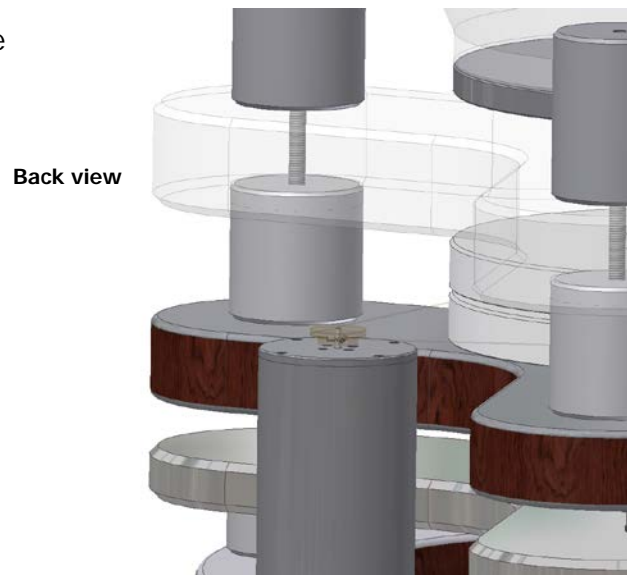

Pic. 21: Placing the drive belt

3.

Plug the supplied Statement power supply first into the back of the motor, and finally into the mains supply.

4.

To assembly the tonearm please refer to the instruction manual of the manufacturer.

The set-up of your *Statement* turntable is now complete!

Clearaudio wish you al lot of pleasure and musical enjoyment with your *Statement* !

5. Special directions

The **Clearaudio** *Statement* does not require any extensive maintenance.

If the *Statement* turntable is not in use for a long time please disconnect the motor from the mains supply.

Every two years you can lubricate (only if you notice speed variation) the bearing of the turntable platter with the supplied oil. In this case it is only necessary to put 4 or 5 drops of the oil onto the bearing shaft.

Don't use abrasive cleaning fluid for the *Statement* turntable. A few drops of window cleaner in a glass of water is sufficient.

Carefully dry all cleaned parts with a cotton lint-free cloth.

The acrylic parts must only be cleaned with special **acrylic cleaning fluids** and under **no** circumstances **spirit** or **fluids based on alcohol**. (To avoid the danger of surface damage!)

You will find suitable cleaning fluids either in specialised shops or in the Clearaudio online shop: www.analogshop.de .

Please take special care to avoid any damage to the power cord.

Any damage should only be repaired only by authorized personal. A damaged power cord must be exchanged immediately!

To achieve the full **Clearaudio** warranty, you are required to fill out and return the corresponding part of the warranty registration certificate /card to **Clearaudio** within two weeks after purchase. Only if the product is returned in it's original packing can **Clearaudio** provide service under warranty.

Transportation advice:

Should it be necessary to transport the *Statement* turntable, always please be sure to remove the turntable platter. Otherwise serious damage can occur!

It is also important that the bearing hole is covered to avoid any dust entering the bearing.

Always take of the pulley off of the motor unit to prevent the motor shaft from any damage.

6. Service

If service or repair on any **Clearaudio** product is necessary, please contact your dealer / distributor or contact **Clearaudio** directly. **Clearaudio** can also inform you of your nearest service location.

Transportation advice:

If any transportation of the *Statement* turntable should be necessary, always please remove the turntable platter. Otherwise serious damage can occur!

The bearing hole needs to be covered as well, to avoid any dust coming into the bearing. Always take of the pulley of the motor unit, to prevent the motor shaft from any damage.

PLEASE RETAIN ALL ORIGINAL PACKAGING. You will need it if this unit has to be transported and / or shipped. Any further questions you may have about this turntable should be directed to the distributor or directly to **Clearaudio** at

Attention:

If the *Statement* is a longer time not in use, please switch the turntable on the main switch on the motor completely off!

Clearaudio electronic GmbH

Spardorfer Str. 150
91054 Erlangen
Germany

Tel/Phone: +49 9131 40300100
Fax: +49 9131 51683

www.clearaudio.de
www.analogshop.de
info@clearaudio.de

7. Technical data

Construction:	Aluminium, stainless steel and bullet proof wood
Weight:	Approx. 350 Kg
Dimensions (W/D/H in inches):	27,2 x 22,4 x 49,2
Dimensions (W/D/H in mm):	690 x 570 x 1250
Power consumption:	
Max. consumption:	19 Watt
Consumption in operation:	8 Watt
Off mode:	0 Watt (if main switch is in "0" position)
Warranty:	10* years

* if the warranty certificate has been correctly filled out and sent back in time .

Clearaudio electronic is not responsible for typographical errors in descriptions. Technical specifications subject to change or improvement without prior notice. Availability as long as stock lasts. Copies and imprints- also only in extracts – require written conformation through **Clearaudio** electronic GmbH; Germany

© Clearaudio electronic GmbH 2008

Version: November 2013

Warranty - information

To achieve the full **Clearaudio** warranty, it is necessary that you fill out and send the corresponding part of the warranty registration certificate /card back to **Clearaudio**, within two weeks after purchase. **Clearaudio** can only provide the 10 year warranty if the product is returned in it's original packing.

ENGLISH **WARRANTY**

For warranty information, contact your local Clearaudio distributor.

RETAIN YOUR PURCHASE RECEIPT

Your purchase receipt is your permanent record of a valuable purchase.

It should be kept in a safe place to be referred to as necessary for insurance purposes or when corresponding with Clearaudio.

IMPORTANT

When seeking warranty service, it is the responsibility of the consumer to establish proof and date of purchase. Your purchase receipt or invoice is adequate for such proof.

FOR U.K. ONLY

This undertaking is in addition to a consumer's statutory rights and does not affect those rights in any way.

FRANÇAIS **GARANTIE**

Pour des informations sur la garantie, contacter le distributeur local Clearaudio.

CONSERVER L'ATTESTATION D'ACHAT

L'attestation d'achat est la preuve permanente d'un achat de valeur. La conserver en lieu sûr pour s'y reporter aux fins d'obtention d'une couverture d'assurance ou dans le cadre de correspondances avec Clearaudio.

IMPORTANT

Pour l'obtention d'un service couvert par la garantie, il incombe au client d'établir la preuve de l'achat et d'en corroborer la date. Le reçu ou la facture constituent des preuves suffisantes.

DEUTSCH **GARANTIE**

Bei Garantiefragen wenden Sie sich bitte zunächst an Ihren Clearaudio-Händler.

Heben Sie Ihren Kaufbeleg gut auf.

WICHTIG!

Die Angaben auf Ihrer Quittung erlauben uns die Identifizierung Ihres Gerätes und belegen mit dem Kaufdatum die Dauer Ihrer Garantie-Ansprüche.

Für Serviceleistungen benötigen wir stets die Gerätenummer.

Diese finden Sie auf dem Typenschild auf der Rückseite des Gerätes oder auch in der beigelegten Garantie-Registrierte Karte.

NEDERLANDS **GARANTIE**

Voor inlichtingen omtrent garantie dient u zich tot uw plaatselijke Clearaudio.

UW KWITANTIE, KASSABON E.D. BEWAREN

Uw kwitantie, kassabon e.d. vormen uw bewijs van aankoop van een waardevol artikel en dienen op een veilige plaats bewaard te worden voor evt. verwijzing bijv., in verband met verzekering of bij correspondentie met Clearaudio.

BELANGRIJK

Bij een evt. beroep op de garantie is het de verantwoordelijkheid van de consument een gedateerd bewijs van aankoop te tonen. Uw kassabon of factuur zijn voldoende bewijs.

ITALIANO **GARANZIA**

L'apparecchio è coperto da una garanzia di buon funzionamento della durata di un anno, o del periodo previsto dalla legge, a partire dalla data di acquisto comprovata da un documento attestante il nominativo del Rivenditore e la data di vendita. La garanzia sarà prestata con la sostituzione o la riparazione gratuita delle parti difettose.

Non sono coperti da garanzia difetti derivanti da uso improprio, errata installazione, manutenzione effettuata da personale non autorizzato o, comunque, da circostanze che non possano riferirsi a difetti di funzionamento dell'apparecchio. Sono inoltre esclusi dalla garanzia gli interventi inerenti l'installazione e l'allacciamento agli impianti di alimentazione.

Gli apparecchi verranno riparati presso i nostri Centri di Assistenza Autorizzati. Le spese ed i rischi di trasporto sono a carico del cliente. La casa costruttrice declina ogni responsabilità per danni diretti o indiretti provocati dalla inosservanza delle prescrizioni di installazione, uso e manutenzione dettagliate nel presente manuale o per guasti dovuti ad uso continuato a fini professionali.

ESPAÑOL **GARANTIA**

Para obtener información acerca de la garantía póngase en contacto con su distribuidor Clearaudio.

GUARDE SU RECIBO DE COMPRA

Su recibo de compra es su prueba permanente de haber adquirido un aparato de valor. Este recibo deberá guardarlo en un lugar seguro y utilizarlo como referencia cuando tenga que hacer uso del seguro o se ponga en contacto con Clearaudio.

IMPORTANTE

Cuando solicite el servicio otorgado por la garantía el usuario tiene la responsabilidad de demostrar cuándo efectuó la compra. En este caso, su recibo de compra será la prueba apropiada.