



**USER MANUAL
MODEL USFT-CS
ULTRASONIC FLOW TRANSMITTER**



**USER MANUAL
DEI MODEL USFT-CS**

The Model USFT-CS is an ultrasonic transit time flow meter designed to accurately and reliably report the flow of non-compressible fluids in pipe diameters ranging from 4 inch to 10 inches. It is a 2-wire device reporting flow in the industry standard 4-20 mA protocol. The meter introduces no pressure drop other than the pipe section which provides the means to position the ultrasonic transducers and to connect to the user's piping system.

The small electronic board which implements all the functions to measure and report the flow is housed in the integral electronic enclosure and is sealed so as to protect the electronics from the environment.

THEORY OF OPERATION

Two ultrasonic transducers are positioned and angled so as to transmit and receive sound pulses that are launched at a flat reflection point located on the opposing side of the pipe. The flight time of the sound pulse from the transmitting transducer to the receiving transducer will be shortened if the pulse is launched in the direction of flow and increased if launched opposite to the direction of flow. By alternating the transmitting and receiving transducers, the difference in these transit times can be used to calculate the velocity of the flow, which when multiplied by the area of the pipe, results in a measure of volumetric flow rate which is then used to set the current in the 4-20 ma loop proportional to the full scale value of the meter.

The path of this sonic pulse traverses the pipe diameter twice and because of the generous spacing between transducers, the volume of fluid which influences the time of flight of this pulse is commensurate with the scale of the turbulence features in the flow. Turbulence by its nature has chaotic velocity components and by directing the sonic pulse through a volume comparable to the scale of this chaos, the effect on the flight time on any single measurement are much reduced, resulting in measurements that show less variation from the average. Stating it another way, a measure of the Standard Deviation of a number of measurements will be reduced, resulting in less uncertainty in the currently reported flow rate.

IMPLEMENTATION

The accuracy and precision of the determined flow rate is ultimately determined by the accuracy and precision with which one can measure the transit times.

**DODGE ENGINEERING & CONTROLS, INC.
196 RIVERNECK ROAD, CHELMSFORD, MA 01824
TEL: (978) 244-1200 FAX: (978) 244-1422
www.DEIcontrols.com**

The Model USFT-CS incorporates a proprietary ASIC (Application Specific IC), which provides all the functions required to alternately transmit and receive sonic pulses and measure the transit times to picosecond accuracy. The ASIC implements the "Sing Around" method to launch and receive pulses, each received pulse initiating the next transmitted pulse. On any one measurement, a number of such cycles are used to accumulate the individual transit times which are then divided by the number of cycles to give an average of these measurements.

A microprocessor provides the following functions:

- Control and calibration of the ASIC.
- Calculations required to convert the measured times to flow rate.
- Setting of the 4-20 mA loop current to represent flow rate.
- Response to User selectable switch settings.
- Fault reporting via an optically isolated open collector output.

INSTALLATION

The Model USFT-CS may be installed in any orientation, although it is recommended that in horizontal pipe runs, an orientation which positions the electrical enclosure vertically be avoided if possible. The reason for this caution is that, with any transit time meter, erratic behavior may result if bubbles are allowed to accumulate in the sound path. A mounting orientation of the electrical enclosure 90° from vertical is recommended. Install with a minimum of five pipe diameters of straight pipe, free of transitions, upstream and two pipe diameters, free of transitions, downstream of the flow transmitter.

DYNAMIC PERFORMANCE

The Model USFT-CS is designed to react to abrupt changes in flow rate. During steady flow, the Model USFT-CS updates the 4-20 mA loop current at a rate determined by the update time as selected by SW2 (fig. 3). This update rate will either be every 10 seconds if "SLOW" response has been set or every 2 seconds if the "FAST" is set. However, if a flow rate is measured that is greater than plus or minus 10% of the current rate, the Model USFT-CS will invoke the 2 second update mode for the duration of the transient change after which it will revert to the selected update rate. This feature is seen as advantageous when the Model USFT-CS is used as the feedback transducer in a process control loop while at the same time the normal update rate has been selected to be the 10 second rate.

In the case of eight or more consecutive bad measurements as

might be experienced if excessive bubble volume is entrained in the flow, the Model USFT-CS will activate the FAULT output opto isolator and simultaneously set the loop current to 3.7 mA to indicate fault condition. This fault condition will be maintained until eight consecutive good measurements are made at which time the Model USFT-CS will revert to its normal mode.

EXCEPTIONAL BEHAVIOR AND FAULT REPORTING

Two fault conditions can be detected and are reported via the Fault output provided (FIG 1).

- Failure of the ASIC to perform necessary internal calibrations.
- Failure to make reliable measurements.

The ASIC must, upon initialization, be able to send and receive sound pulses of a minimum strength. If it cannot, no measurements can be made. This may come about for two reasons:

- The most likely reason the ASIC cannot be calibrated is because of a sound path that is not completely through the fluid. This would be the case if the pipe were not completely filled with fluid.
- Although the pipe may be properly filled, bubbles of air trapped near a transducer would also preclude a calibration.
- Lastly and of least likelihood would be a system failure. Such a failure may be a degraded transducer. Less likely may be a failure in the control electronics.

Watchdog Timer:

The software includes a Watchdog timer which will cause a software reset should, for whatever reason, the code is not being normally exercised for more than about 2 seconds. This reset will normally be transparent to the user. Should permanent damage to the unit have occurred, the normal fault reporting cannot be invoked and the Model USFT-CS will have to be replaced.

USER SELECTABLE OPTIONS

There are three switches (FIG 3) accessible when the controller board is exposed. Their functions are as follows:

- **Reset.**

- This is a small push button switch which when activated resets the software as would occur if the unit were power cycled.

- **Full Scale**

- This is a dip switch setting that allows the User to select between two pre-programmed full scale values for the pipe diameter currently used. See the Specification section for detail.

- **Response Time**

- This switch setting allows the User to select two different update rates. In many applications, a longer update rate is desired and acceptable. With this slower update rate, the Model USFT-CS will average readings over a longer time, resulting, (in the case of steady flow), a more constant reported flow rate. See the Specification section for details.

- In the case where the Model USFT-CS is to be used as a feedback transducer in a control loop, a faster response time may be desirable.

Use:

If either the Full scale or Response Time switch has been changed since the last Reset or power cycle, then the Model USFT-CS must be reset using the Reset switch or else power cycled.

CALIBRATION

As mentioned in the "Theory of Operation" and the "Implementation" sections, the Model USFT-CS employs the Sing Around method of determining transit times. This method results in a measurement of fluid velocity which is independent of the speed of sound through the fluid and hence its dependence on temperature. This speed of sound independence removes all need for field calibration.

However, to report volumetric flow rate, this velocity must be multiplied by the cross sectional area through which the velocity was measured. This area is set by the internal pipe diameter, D. Any uncertainty in D translates directly to an uncertainty in flow rate, Q. Quantitatively,

$$Q(\% \text{ error}) = 200 * d/D, \text{ where } d \text{ is the } +/- \text{ tolerance of } D.$$

As an example, a +/- .01 inch uncertainty in the nominal diameter of a 2 inch pipe would result in a +/- 1 % error in reported flow rate, Q.

At DEI each meter is calibrated against a traceable standard meter and a constant set in software, which reflects this actual diameter rather than the nominal diameter. This method of calibration removes an otherwise indeterminate error.

The error resulting from the thermal expansion of the diameter over the specified temperature range would however result in the flow rate being under reported by 0.1 %.

SPECIFICATIONS

GENERAL

Flow Range: Bi-directional, field selectable per "Standard Models" table

Accuracy: ±0.75% of full scale

Operating Temperature: -40 to 190°F (-40 to 87.8°C)

Response Time: User selectable, 2 or 10 seconds

Viscosity Range: 0.2 to 150 cSt (0.2 to 150 mPas)

Liquid Density: 30.6 to 74.9 lb/cu.ft. (490 to 1200 kg/m³)

Max. Working Pressure: 200 PSI

Pipe Sizes: 4", 6", 8", 10"

Pipe Connections: ASME class 150 flange

Electrical Enclosure: Integral to Body casting with gasketed cover; One 1/2" NPT conduit connection (plugged when model ordered with metric threads) and one M16 x 1.5 connection (plugged when model ordered with NPT threads)

Electrical Connections: Screw terminal connections on PC board

Enclosure Rating: NEMA 4 (IP 65)

Power: 18 to 36 VDC

WETTED MATERIALS

Ultrasonic Transducers: ULTEM® Encapsulated

Seals: EPDM, Buna-N, Neoprene™, FKM, or other

Body Material: Schedule 40, epoxy coated, carbon steel pipe

OUTPUT

Analog: 2-wire, 4-20 mA output; Output is 4 mA from zero to min. flow (see Standard Model table)

Loop Resistance: See FIG. 2

Error Detection: An optically isolated sink output is activated under certain detectable fault conditions, such as transducer failure or overly noisy output due to flow stream anomalies, as might be seen due to excessive bubble entrainment. The optional Fault output is an optically isolated NPN transistor capable of sinking up to 10 ma from a voltage source of no more than 48 VDC.

Caution: There is no current limiting on this output so care must be exercised to limit the sink current to less than 25 ma and insure that proper polarity, as shown in Fig.1, is observed else permanent damage may result.

Direction of Flow: Optional output to indicate direction of flow is available. Activation or deactivation of an optically isolated 10 mA (max. 48V no load voltage) sink output indicates flow direction. Error detection is not available when this option is ordered.

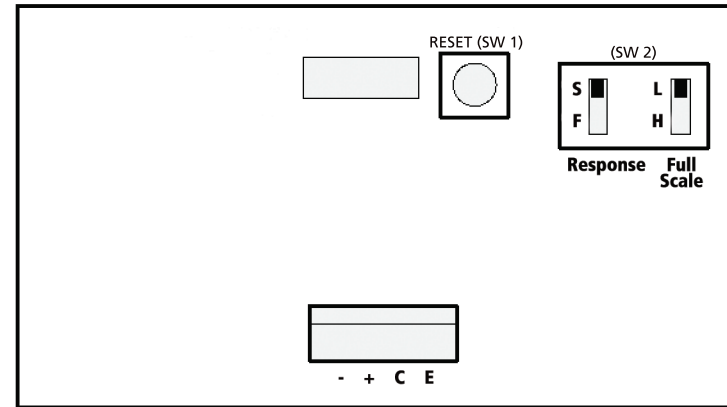

BOARD LOCATIONS OF REFERENCED USER FUNCTIONS

FIG 3

Response Time Switch Position	Range Switch Position (See Standard Models Table)
S= 10 Seconds F= 2 seconds	L= Low Standard Range H= High Standard Range

STANDARD MODELS

Model	Pipe Size	*Field Selectable Full Scale Ranges (GPM)		*Field Selectable Full Scale Ranges (LPM)		
		Min.	Max.	Min.	Max.	
USFT-CS-4.0	4"	L	3.75	300	14.38	1150
		H	6.25	500	23.75	1900
USFT-CS-6.0	6"	L	7.50	600	28.75	2300
		H	15.0	1200	56.25	4500
USFT-CS-8.0	8"	L	12.5	1000	47.50	3800
		H	25.0	2000	95.00	7600
USFT-CS-10	10"	L	18.75	1500	71.25	5700
		H	37.50	3000	137.50	11000

*F.S. ranges can be user specified to 125% of each stated high (H) range with no change to specifications and to 25% of each low (L) range with some specification modification. Consult factory.

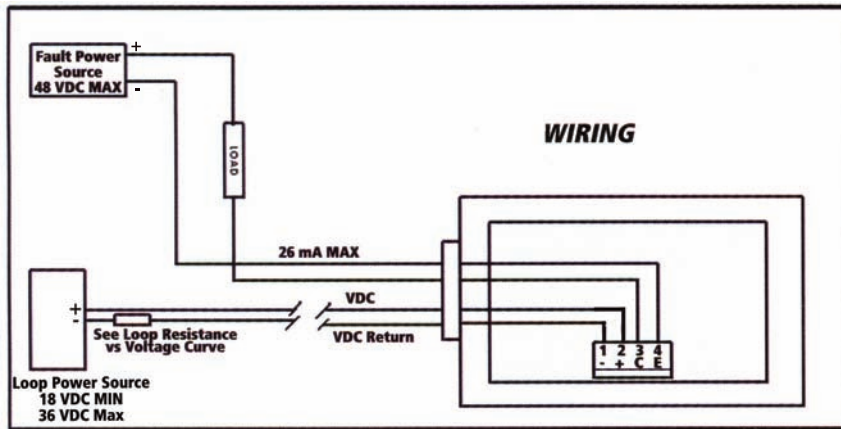

FIG 1

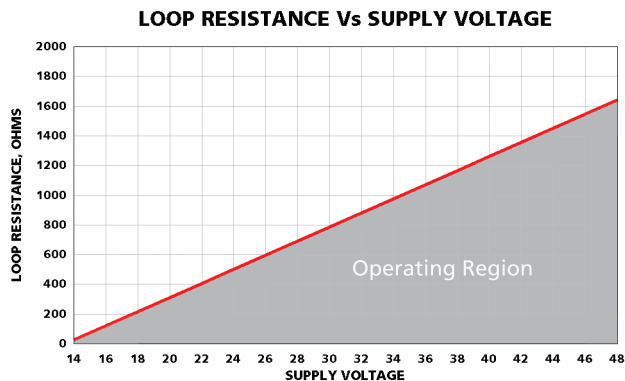
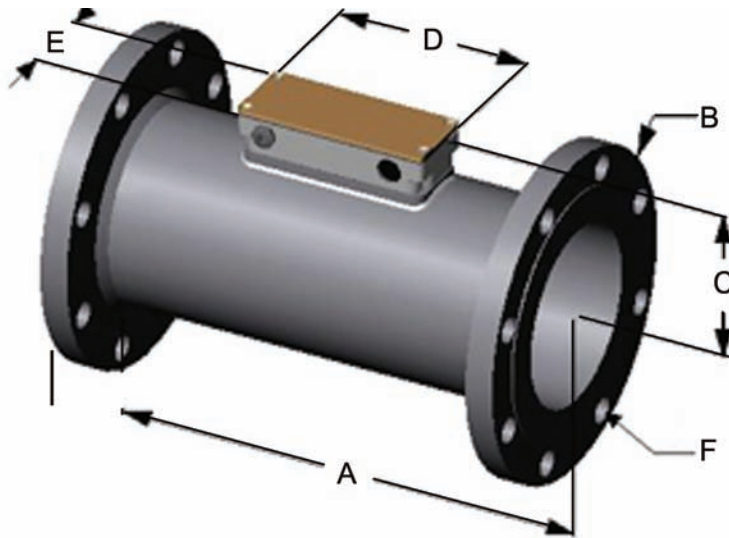

FIG 2

DIMENSIONS



Pipe Size	Dimensions (Inches)							Bolt Circle	Number of
	A	B	C	D	E	F			
4"	13.00	9.00	4.00	6.54	2.62	0.75	7.50	8	
6"	16.00	11.00	5.09	6.54	2.62	0.88	9.50	8	
8"	18.00	13.50	6.11	6.54	2.62	0.88	11.75	8	
10"	22.00	16.00	7.18	6.54	2.62	1.00	14.25	12	

CAUTION

Model USFT-CS is for measurement of liquid flows only

Use only with liquids compatible with the materials of construction

Maximum Pressure: 200 PSIG

Maximum Temperature: 190°F