

## KIT AUDIO DOOR PHONE basic 1 family

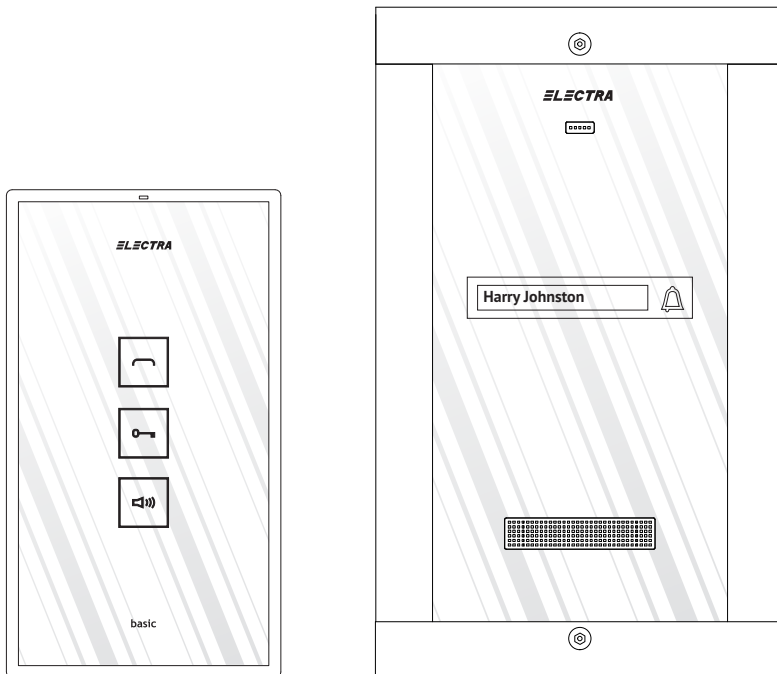
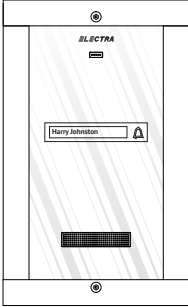
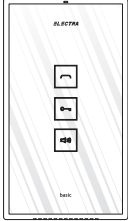
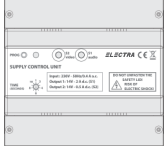

- Call from the Outdoor panel's key;
- Full duplex hands-free audio communication;
- Command of the access gate/door opening from the interior Terminal;
- Audio monitoring of the entrance of the property, by the inhabitant;
- *Optional 1 audio Terminal in parallel;*
- UTP CAT 5e (AWG 24) cable required.

## 1 KIT COMPONENTS

		
<p>Outdoor panel 1 pc. 238 × 144 × 53 mm</p>	<p>Terminal 1 pc. 170 × 96 × 30 mm</p>	<p>Supply control unit 1 pc. 130 × 141 × 73 mm</p>

## 2 TECHNICAL FEATURES OF THE SYSTEM

Audio communication	Full-duplex
Data communication	Digital
Supply tension of the system (supply of the control unit)	230 V±10% / 50 Hz
Maximum power expenditure from the 230 V AC network	0,4 A AC

### 2.1 Technical features of the outdoor audio panel

Supply tension	12,0 ... 14,3 V DC (stabilized)
Keyboard	TOUCH type, permanently backlit
Display of the inhabitant's name	Backlit name space
Case	Aluminum profile painted in electrostatic field; Secured glass screen, 8 mm thick
Mounting	Flush
Casing protection level (IP)	IP44
Operating temperature range	- 30° C ... + 60° C
Transport and storage temperature range	- 33° C ... + 55° C
Dimensions	238 x 144 x 53 mm
Weight	1,3 kg

## 2.2 Technical features of the audio Terminal

EN

Supply tension	12,0 ... 14,3 V DC (stabilized)
Keyboard	TOUCH type, 4 keys, backlit on touch
	Permanent RED signaling of the VOLUME key if the Terminal is turned off.
Audio adjustments	Audio communication volume: MAXIMUM LEVEL – MEDIUM LEVEL – TURNED OFF
Case	ABS Glass screen, 3 mm thick
Mounting	Surface
Casing protection level (IP)	IP31
Operating temperature range	0°C ... + 45°C
Range of transport and storage temperatures	- 33°C ... + 55°C
Dimensions	171 x 96 x 30 mm
Weight	0,4 kg

## 2.3 Technical features of the Supply control unit

Supply tension	230V±10%/50Hz						
Generated power tensions/ power capability	<table border="0"> <tr> <td><span style="border: 1px solid black; padding: 2px;">+14V</span> – <span style="border: 1px solid black; padding: 2px;">GND</span></td> <td>: +14V DC (stabilised) / 2A DC</td> </tr> <tr> <td><span style="border: 1px solid black; padding: 2px;">+Uv</span> – <span style="border: 1px solid black; padding: 2px;">GND</span></td> <td>: +14V DC (stabilised) / 0,5A DC</td> </tr> <tr> <td><span style="border: 1px solid black; padding: 2px;">Vcam</span> – <span style="border: 1px solid black; padding: 2px;">GND</span></td> <td>: +12V DC (stabilised) / 0.4 A DC</td> </tr> </table>	<span style="border: 1px solid black; padding: 2px;">+14V</span> – <span style="border: 1px solid black; padding: 2px;">GND</span>	: +14V DC (stabilised) / 2A DC	<span style="border: 1px solid black; padding: 2px;">+Uv</span> – <span style="border: 1px solid black; padding: 2px;">GND</span>	: +14V DC (stabilised) / 0,5A DC	<span style="border: 1px solid black; padding: 2px;">Vcam</span> – <span style="border: 1px solid black; padding: 2px;">GND</span>	: +12V DC (stabilised) / 0.4 A DC
<span style="border: 1px solid black; padding: 2px;">+14V</span> – <span style="border: 1px solid black; padding: 2px;">GND</span>	: +14V DC (stabilised) / 2A DC						
<span style="border: 1px solid black; padding: 2px;">+Uv</span> – <span style="border: 1px solid black; padding: 2px;">GND</span>	: +14V DC (stabilised) / 0,5A DC						
<span style="border: 1px solid black; padding: 2px;">Vcam</span> – <span style="border: 1px solid black; padding: 2px;">GND</span>	: +12V DC (stabilised) / 0.4 A DC						
Case	Fireproof ABS						
Mounting	On DIN rail: TH 35 x 15 or 35 x 7,5 in compliance with DIN46277-3, EN50022, IEC60715 Surface: with A3,5 x 32 plastic screws and ø 6 mm pins						
Casing protection level (IP)	IP31						
Operating temperature range	0°C ... + 45°C						
Range of transport and storage temperatures	- 33°C ... + 55°C						
Dimensions	130 x 141 x 73 mm						
Weight	0,4 kg						

### 3 BLOCK DIAGRAM OF THE SYSTEM

! All additional products are sold separately.

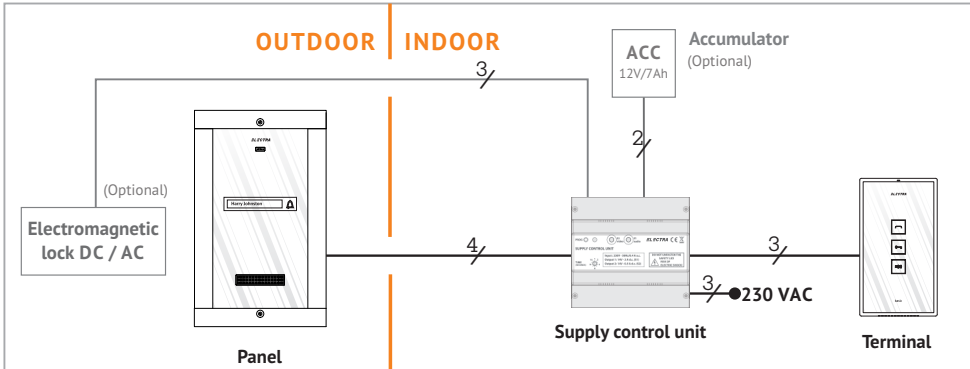

#### Additional terminals in parallel (optional)

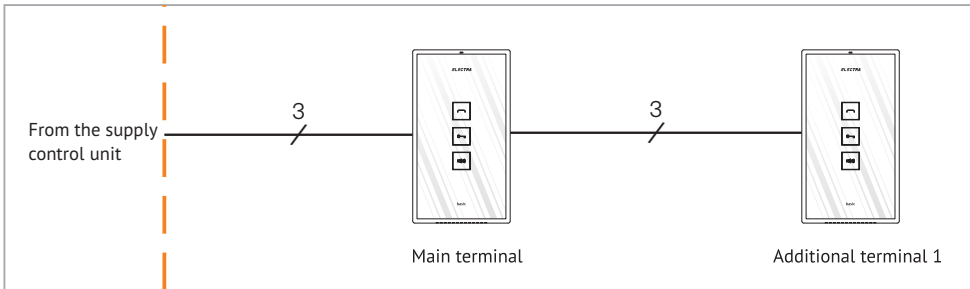

### 4 INSTALLATION

#### 4.1 Recommended cables

##### Outdoor panel → Supply control unit → Audio Terminal

UTP CAT5e (AWG24) cable for distances of maximum 70 m between the Outdoor panel and the Supply control unit and 250m between the Outdoor panel and the audio Terminal. For distances greater than 250 m, please request additional information from the producer.

##### Supply control unit → Electromagnetic lock (optional)

Flexible, multistrand cable, (Cu) 2 or 3 x 0,75 mm<sup>2</sup> for distances of maximum 50 m or (Cu) 2 or 3 x 1 mm<sup>2</sup> for distances of maximum 100 m.

##### Supply control unit → 230 V AC network

Flexible, multistrand cable, (Cu) 3 x 0,75 mm<sup>2</sup>

## 4.2 Safety instructions for installation



- **ATTENTION!** The installation, the connection to the 230V/50 Hz network and the maintenance of the Supply control unit Supply control unit will only be carried out by authorized personnel!
- The installation of the Supply control unit is recommended to be made within an electrical panel.
- **ATTENTION! DO NOT UNFASTEN THE FRONT LID! DANGER OF ELECTRIC SHOCK!**  
Only the protection lids of the connections can be unfastened.
- **ATTENTION!** It is mandatory for the supply of the Supply control unit from the 230 V/50Hz network to be made through two automatic fuses of 10 A (on phase and null). The connection of the F and N terminals of the Supply control unit will be made through two isolated (Cu) wires, with a section of 0,75mm<sup>2</sup>.
- **ATTENTION!** During the installation, connection of the Supply control unit at the 230 V/50Hz network and during service, the safety fuses from the panel must be opened (POWER OFF).
- The connection of the (Cu) 0,75mm<sup>2</sup> grounding wire between the grounding terminal of the electrical panel (⏚) and the grounding terminal of the Supply control unit (⏚) is **MANDATORY**.
- **IMPORTANT!** Before connecting the Supply control unit's supply fuses, check the precision of the connections in the system. Check both visually, and by measurement with an ohmmeter.
- **IMPORTANT!** Install the protection lids of the Supply control unit's connections before connecting the 2 supply fuses (230V/50Hz).
- **PAY ATTENTION** to the polarity of the terminals when connecting them to the Supply control unit of a buffer accumulator (max. 7 Ah). The inversion of the terminals leads to the failure of the accumulator. The installation and connection of the accumulator will be carried out by authorized personnel.
- **DO NOT TOUCH** the wires exiting from the connectors and the terminals of the control supply unit. Disconnect the fuses (10 A) from the supply's phase and null of the Supply control unit.
- **ATTENTION!** Do not supply components of the installation separately (Outdoor panel, connection boxes, Terminals etc.) at tensions higher than 15V DC or directly from the network (230V/50Hz). **DANGER OF ELECTRIC SHOCK** and of the door phone system's destruction.

## 4.3 Installation of the supply control unit

### DIN rail mounting

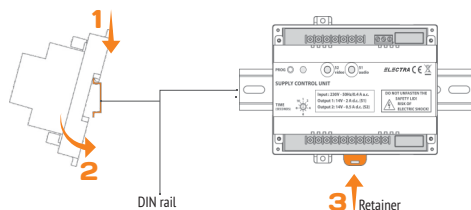

### Wall mounting

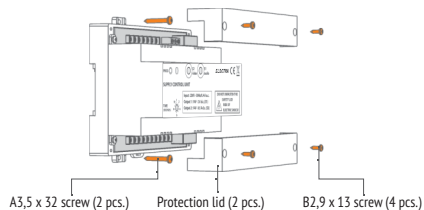

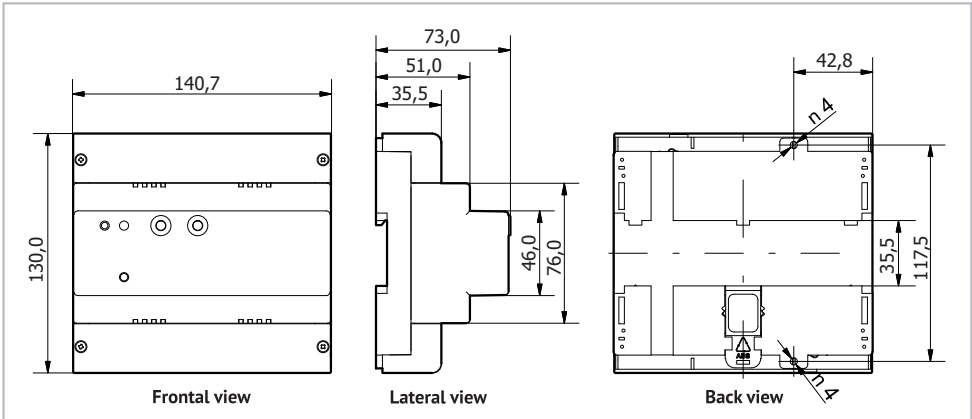

The accumulator will be connected to the terminals of the power supply, after the commissioning of the system.

#### 4.4 Installation of the audio terminal

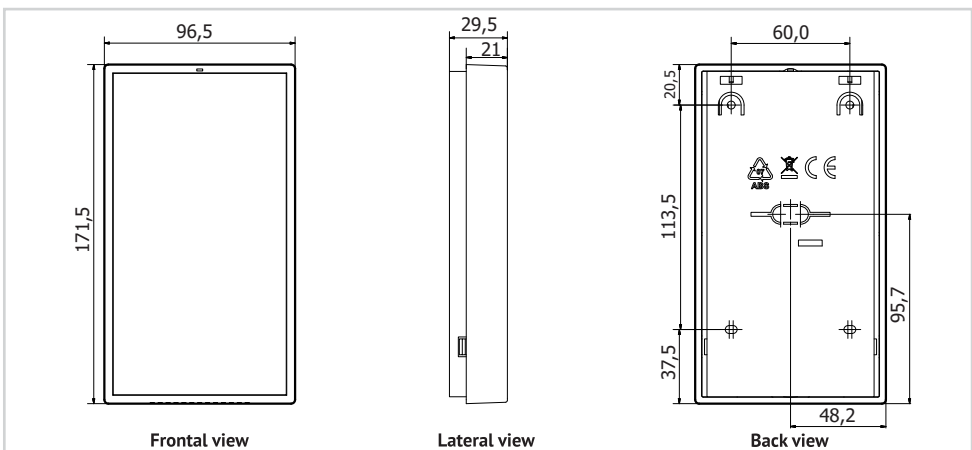
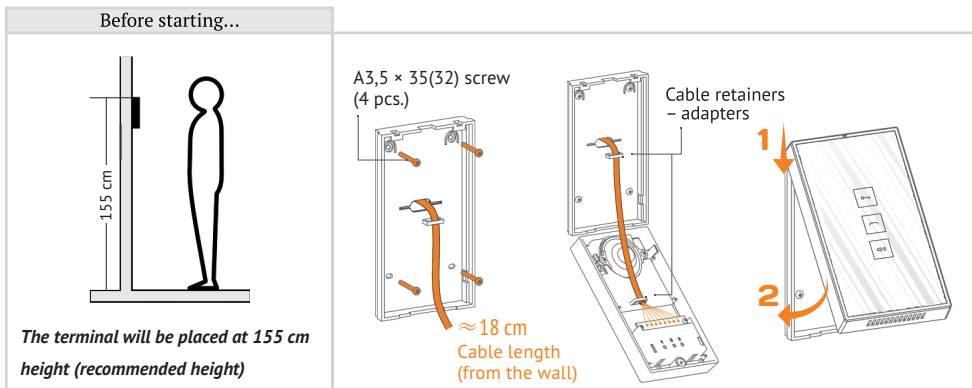

## 4.5 Installation of the Outdoor panel

EN

The Outdoor panel is installed at the entrance of the property or building, on the body closest to the access door, at a height of approx. 1.7 m (upper part) from the ground, protected from rain and sunrays.

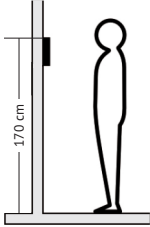
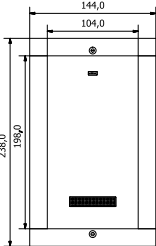
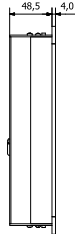
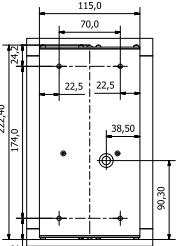
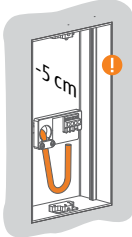
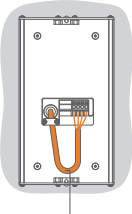
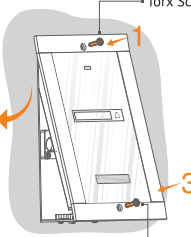
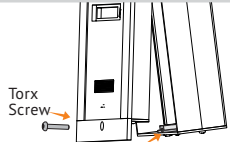
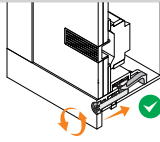
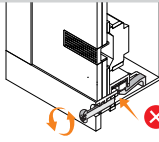
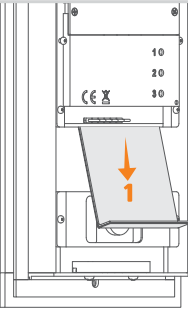
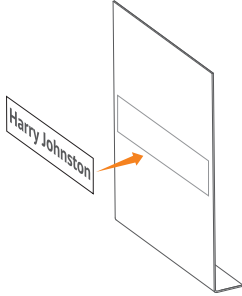
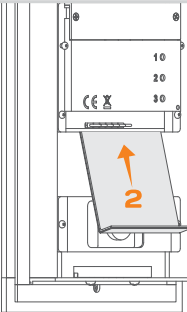
<p><b>Before starting...</b></p>  <p>The <b>Outdoor panel</b> is installed at the entrance to the building, on the body closest to the entrance door.</p>	 <p>Frontal view</p>	 <p>Lateral view</p>	 <p>Back view</p>
 <p>The frame of the case must be at the level of the wall's surface.</p> <p>≈ 20 cm cable length</p>	 <p>Door phone cable</p>	 <p>Torx Screw</p> <p>1</p> <p>2</p> <p>3</p> <p>Torx Screw for antitheft protection</p>	
<p><b>Antitheft protection</b></p>			
<p>1</p>  <p>Torx Screw</p>	<p>2</p> 	<p>3</p> 	
<p>The Torx screw must be completely screwed. Otherwise, when the system is powered, the panel emits a permanent acoustic signal. This warning function is useful if an unauthorized person tries to open the Outdoor panel. The alarm turns on immediately after one starts to unscrew the Torx. The function is turned off during the programming of the panel's parameters.</p>			
<p><b>Customization of the name display</b></p>			
 <p>1</p>	 <p>Harry Johnston</p>	 <p>2</p>	
<p>Remove the plastic pad from the keyboard module</p>	<p>Affix a sticker with the name, cut to size, on the white space allocated to it.</p>	<p>Insert the pad back in the keyboard module</p>	

## 5 CONNECTION DIAGRAM

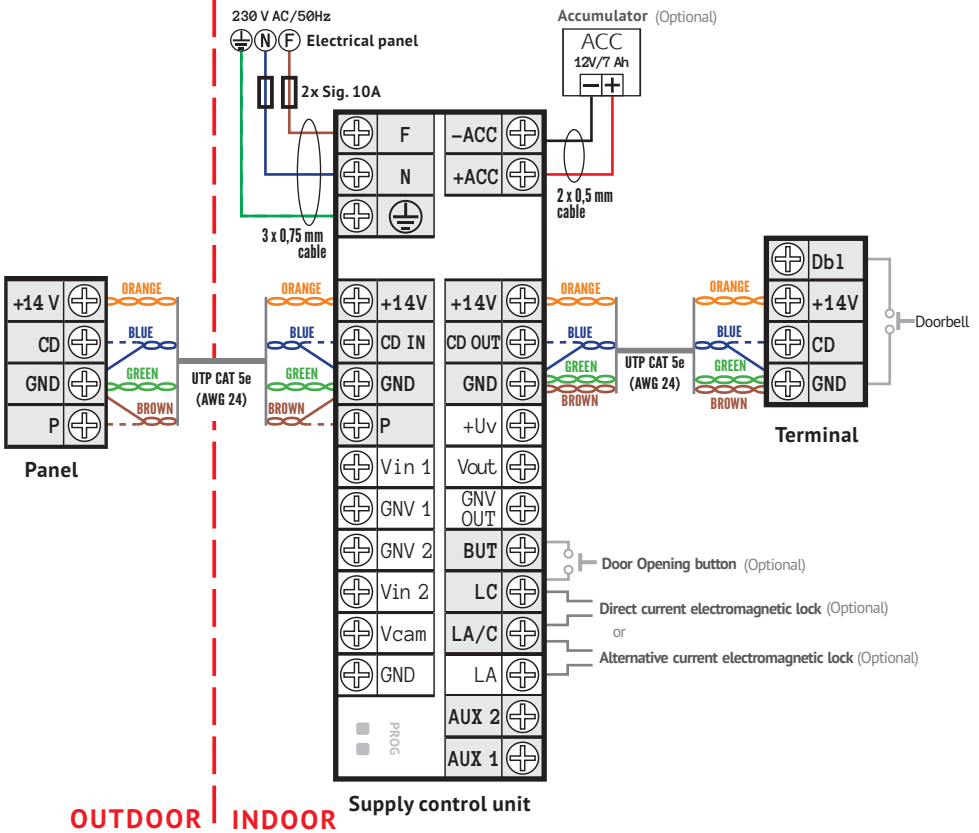

### 5.1 Installation of the electromagnetic lock (optional)

#### Direct current (DC)

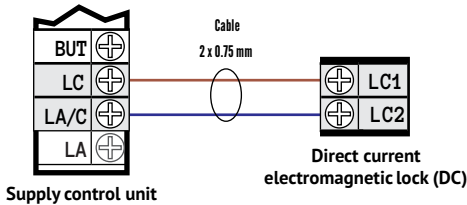

- The Supply control unit can supply a current of max. 1A for the supply of the lock.
- The tension of +14 V DC is present on the LC terminal of the Supply control unit.
- The connection of a lock actuating button from the interior of the building will be made at the BUT and LC terminals of the Supply control unit.

#### Alternative current (AC)

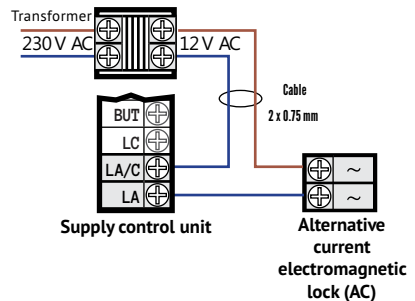

- The Supply control unit can supply a current of max. 1A for the supply of the lock.



## 6.1 Description of the Supply control unit

The **supply control unit** includes:

\*PROG. : programming button

*\*The kit does not require programming. This button is used only if you add additional Terminals or Panels to the system.*

*RED signaling of PROG = defect within the system*

TIME:  
Lock timing adjustment

S1: presence of tension at the **+14V** - **GND** terminals  
S2: existence of tension at the **+Uv** - **GND** terminals

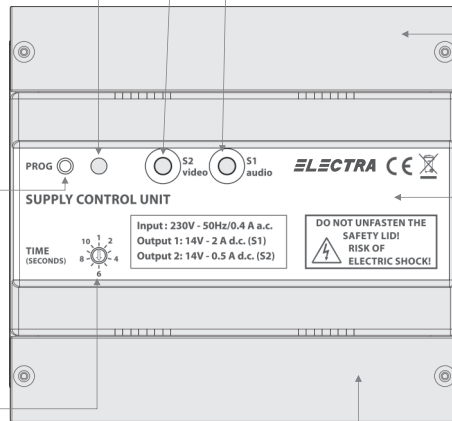

Protection lid for connections

Front lid

Protection lid for connections

## 6.2 Checking the precision of the connections in the system and the connection of the supply control unit

**Check the precision of the connections in the system!**

The **+14V**, **GND**, **CD** signals are common to all components of the system. Any short circuit between them leads to the non-operation of the entire system. With an ohmmeter, check that there is no short circuit between any terminals, anywhere in the system.

**⚠ Make sure that the Torx screw of the Outdoor panel is completely screwed to prevent turning on the anti-theft alarm.**

**Connect the Supply control unit to the 230 V AC network, by connecting the two automatic 10A fuses, installed on phase and null.**

Optionally, connect the accumulator to the **+ACC** and **-ACC** terminals of the Supply control unit.

**⚠ PAY ATTENTION to the polarity of the accumulator!**

**Check the existence of the supply tensions with the values mentioned below, at the terminals of the Supply control unit (use a direct current voltmeter).**

- Tensions measured at the terminals of the Supply control unit : **+14V** - **GND** / 13,8 ... 14,3V DC
- The tension **+Uv** - **GND** / 13,5 ... 14,3V DC is not used by the audio systems.
- Tensions measured at the terminals of the Outdoor panel and at the terminals of the Terminals: **+ 14V** - **GND** min. 12 V DC

## 6.3 Checking the functions and adjustments

**Check** anywhere in the installation, during the call and the communication, and make sure that the +14V  
 – GND supply tension is higher than 12,0V.

**Check** the functions of the Terminals and of the Outdoor panel: call, communication, access, audio monitoring. The system is adjusted by the producer in what concerns the audio part, for standard functioning conditions

### How to adjust the volume of the audio Terminal

Through consecutive touches of the VOLUME key, different audition levels are obtained: **OFF** (mute) – red LED, **MEDIUM** white-red LED, **MAXIMUM** – white LED

**!** *After checking, leave the Terminal on the open volume position (white LED on).*

## 6.4 Troubleshooting



**Any intervention in the system will be made with the system disconnected from the 230VAC supply network (the phase and null fuses are opened) and from the accumulator (the +ACC terminal is disconnected).**

No.	Problem	Signaling	Possible causes	Solutions
0	The system functions correctly	<u>Control unit:</u> S1: green S2: green PROG: _____	_____	_____
1	The system does not function (supply control unit without accumulator)	<u>Control unit:</u> S1: _____ S2: _____ PROG: _____	Lack of tension from the 230VAC network	Check the 10A fuses from the electrical panel and the 1,6A Fuse 1 from the Supply control unit input. Check the continuity of the supply cables.
2	The system does not function (supply control unit without accumulator)	<u>Control unit:</u> S1: intermittent green S2: _____ PROG: _____	Short circuit in the system between <span style="border: 1px solid black; padding: 2px;">+14V</span> and <span style="border: 1px solid black; padding: 2px;">GND</span>	Identify the spot of the short circuit. Remedy the defect and turn the system on.
3	The CALL does not function	<u>Control unit:</u> S1: green S2: green PROG: _____ <u>Terminal:</u> The keyboard is functioning, it does not take the call command. <u>Outdoor panel:</u> Emits an error signal .	No <span style="border: 1px solid black; padding: 2px;">CD</span> connection at the terminals of the Terminal, or <span style="border: 1px solid black; padding: 2px;">CD</span> wire interrupted before reaching the terminals of the Terminal.	Connect the <span style="border: 1px solid black; padding: 2px;">CD</span> to the Terminal or check the continuity of the <span style="border: 1px solid black; padding: 2px;">CD</span> wire from the audio connection box to the Terminal.

4	The CALL does not function	<u>Control unit:</u> S1: green S2: green PROG: intermittent red <u>Terminal:</u> The keyboard is functioning, it does not take the call command. <u>Outdoor panel:</u> Emits an error signal.	Short circuit between the <b>CD</b> and <b>GND</b> or <b>+14V</b> connections	Remedy the short circuit. (by case)
5	The system functions (supply control unit with accumulator)	<u>Control unit:</u> S1: red – intermittent green S2: green PROG: ———	The accumulator is in charging mode	ok
6	The system functions (Supply control unit with accumulator)	<u>Control unit:</u> S1: red – intermittent green S2: green acoustic signal PROG: ———	Defect accumulator or discharged	Change or recharge the accumulator
7	The system functions (supply control unit with accumulator)	<u>Control unit:</u> S1: red S2: ——— PROG: ———	Lack of tension from the 230V AC network The system functions powered by the accumulator.	Check the 10A fuses from the electrical panel and the 1,6A Fuse 1 from the Supply control unit input. Check the continuity of the supply cables.

## 7 USE

### 7.1 User safety instructions



**Do not hit the glass screen with hard objects!**  
**If the front glass screen cracks, DO NOT touch the product!**

## 7.2 Use of the audio Terminal

### 1 STAND-BY

At the first touch, the keyboard is backlit and the Terminal may receive the following commands:

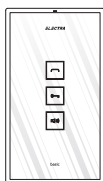

Stand-by



#### AUDIO MONITORING

Monitoring duration: 10 s

By touching this key, you may listen to what goes on at the entrance, in front of the Outdoor panel. Monitoring is not possible if another Terminal of the system is being called or is during communication.



#### VOLUME ADJUSTMENT OR "TERMINAL TURNED OFF"

By successive touches of this key, the 3 volume levels are passed through: maximum (white LED), medium (red-white LED) and turned off (red LED). The red LED will remain permanently turned on until the key is pressed again.

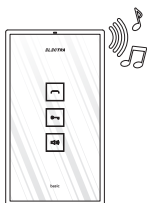

Call

### 2 CALL AND COMMUNICATION

Call duration: maximum 15 s (3 calls)



#### ANSWER THE CALL

Communication duration: maximum 2 min.

The LED of the key blinks.

By touching the key, communication is initiated. The LED does not blink anymore.

Do not touch the  key during communication.



#### END COMMUNICATION WITHOUT ACCESS!

The second touch of the key ends communication without granting access and the Terminal returns to stand-by mode.

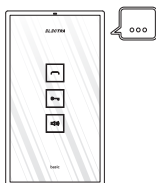

Communication

### 3 ACCESS



#### ACCESS and END COMMUNICATION!

After the command, the lock is unblocked for 1...10 s for the access of the visitors.

//You cannot grant access without having a prior communication.



### 1 STAND-BY

The key of the Outdoor panel and the inhabitant's name are permanently backlit.

### 2 CALL AND COMMUNICATION

Call duration: maximum 15 s (3 calls)

Communication duration: maximum 2 min.

Touch the  key.

The call to the inhabitant is signaled acoustically. You may end the call by pressing again the  key. If the inhabitant answers, communication is initiated. If access is granted, the panel emits an acoustic signal, and the lock remains unblocked for maximum 10 seconds. If the inhabitant does not answer, after a minute, the panel returns to stand-by mode.

## 8 MAINTENANCE

The outdoor panels must be kept away from corrosive substances, lime or mechanical shocks. The terminals must be kept away from water, or any other liquids, mechanical shocks, fumes, dusts etc.

The components of the system can be cleaned with a piece of soft, cotton cloth.

The optional accumulator connected with the supply control unit will be replaced after the expiry of its life span. The supply control unit ensures the accumulator's charging, as long as the accumulator is not defect. The state of the accumulator is indicated by the signals of the LED S1 and the acoustic warning in case of a defect.

## 9 WARRANTY

A three year warranty is granted, from the purchase date, on the basis of the proof of purchase and if the system was used according to the technical manual.



**NO WARRANTY IS GRANTED** for: inappropriate installation and use, deliberate damaging, theft, arson, natural disasters, unauthorized interventions to the system, the lack of protection of the system's components in case of renovation activities in the building.

*The ELECTRA systems for residential buildings are produced in compliance with the EU standards and bear the CE conformity marking.*

## 10 AUTHORIZED REPRESENTATIVE of ELECTRA S.R.L.

### ELECTRA Building Communications GmbH

Parking 10, Liebenberggasse 7 | 1010 Wien – Austria

Phone +43 1 516 33 – 3817 | Fax + 43 1 516 33 – 3000

office@electra-automation.at

**Designed and Manufactured by ELECTRA**

**Made in EU**

