



USER MANUAL

- Longo modbus product
LMP-1.MP1H
Modbus RTU Temperature
Humidity Control panel

Version 2

Written by SMARTEH d.o.o.
Copyright © 2015, SMARTEH d.o.o.

User Manual

Document Version: 001
November, 2015



STANDARDS AND PROVISIONS: Standards, recommendations, regulations and provisions of the country in which the devices will operate, must be considered while planning and setting up electrical devices. Work on 230 V AC network is allowed for authorized personnel only.

DANGER WARNINGS: Devices or modules must be protected from moisture, dirt and damage during transport, storing and operation.

WARRANTY CONDITIONS: For all LONGO LMP - if no modifications are performed upon and are correctly connected by authorized personnel - in consideration of maximum allowed connecting power, we offer warranty for 24 months from date of sale to end buyer. In case of claims within warranty time, which are based on material malfunctions the producer offers free replacement. The method of return of malfunctioned module, together with description, can be arranged with our authorized representative. Warranty does not include damage due to transport or because of unconsidered corresponding regulations of the country, where the module is installed.

This device must be connected properly by the provided connection scheme in this manual. Wrong installation may result in device damage, fire or personal injury.

Hazardous voltage in the device can cause electric shock and may result in personal injury or death.

NEVER SERVICE THIS PRODUCT YOURSELF!

This device must not be installed in the systems critical for life (e.g. medical devices, aircrafts, etc.).

If the device is used in a manner not specified by the manufacturer, the degree of protection provided by the equipment may be impaired.

Waste electrical and electronic equipment (WEEE) must be collected separately!

LONGO LMP-2 complies to the following standards:

EMC: IEC/EN 61000-6-2(EN 50082),
IEC/EN 61000-6-4(EN 50081),

LVD: IEC 61131-2,

Vibrations and climatic-mechanical: EN 60068-2-6,
EN 60068-2-27,
EN 60068-2-29.

SmarteH d.o.o. operates a policy of continuous development. Therefore we reserve the right to make changes and improvements to any of the products described in this manual without any prior notice.

MANUFACTURER:
SMARTEH d.o.o.
Poljubinj 114
5220 Tolmin
Slovenia



Index

Longo modbus product LMP-1.MP1H

1 ABBREVIATIONS.....	1
2 DESCRIPTION.....	2
3 FEATURES.....	3
4 OPERATION.....	4
4.1 Operational modes.....	4
4.2 Functions	5
4.3 Parameters.....	6
4.4 Modbus RTU variables memory.....	8
4.5 Modbus RTU settings memory.....	10
5 INSTALLATION.....	11
5.1 Connection scheme.....	11
5.2 Mounting frame selection.....	13
5.3 Mounting instructions.....	14
5.4 Module labeling.....	15
6 REGULATION DIAGRAM.....	16
7 TECHNICAL SPECIFICATIONS.....	17
8 CHANGES	18
9 NOTES.....	19



1 ABBREVIATIONS

Sorted by order of appearance in document:

SP	Set point
CP	Control Panel
TB	Touch Button
LCD	Liquid crystal display



2 DESCRIPTION

LMP-1.MP1H Modbus RTU Slave compatible control panel (CP) is used for room temperature and humidity regulation using fan-coil or other heating/cooling devices.

Panel is equipped with temperature and light intensity sensor and four touch buttons (TB). To increase, decrease temperature set point *warmer*, *cooler* TB should be pressed respectively. Temperature SP is represented with right LCD bar-graph. While CP is in heating mode (temperature SP is higher than actual room temperature), LCD SP bar is red and while in cooling mode (temperature SP is lower than actual room temperature), LCD SP bar is blue. If actual temperature is in SP +/- Dead band range, LCD SP bar is white.

With *fan TB* speed I, speed II, speed III, AUTO or OFF modes of operation can be selected. Fan mode is represented with left blue LCD bar-graph.

With ECO (economy), OFF and ERR (error) signs on LCD, CP status is represented.

Color back ground LCD picture is possible to customize by using Smarteh LCD Composer software. Light intensity sensor controls LCD intensity.

It is possible to display actual temperature value (0.5 °C resolution), temperature set point and humidity (1 % resolution). The real time clock (HH:MM) can also be displayed. Enabling can be done by MCU enable commands.

All parameters are accessible on panel's communication port. When panel is connected to Modbus RTU Master equipment, parameters can be viewed and modified.

LMP-1.MP1H parameters and functions allows adaptation to desired system and regulation diagram.

Panel is able to regulate 2 or 4-pipe systems, depending on *4/2 pipe* parameter.



3 FEATURES



Figure 1: LMP-1.MP1H module.

Table 1: Technical data

Room temperature and humidity measurement
2 touch buttons for temperature set point
2 touch buttons for manual fan speed, auto and controller off
10 position LCD bar-graph for temperature set point
4 position LCD bar-graph for manual fan speed, auto and controller off
Light intensity measurement
LCD intensity control
Step-less or 3 step fan motor controlling
Economic function
2/4 pipe heating cooling system supported
Balcony door/window function
Frost protection function
Color LCD display with background picture customization possibility ¹

¹ For LCD background picture replacement, please refer to LCD Composer → Help.



4 OPERATION

Basic settings can be entered with panel Touch Buttons (TB).

Modes of operation and parameters can be set from any Modbus RTU Master equipment.

It is advised to press touch-buttons respectively with finger not faster than 1 press per second.

Press should be done with whole finger tip. Brief pressing could not activate the action, because of protection against the noise and other influence.

4.1 Operational modes

LCD Display “stand-by mode”

The display is normally in this mode, if no TB is pressed in last ~5 seconds.

LED intensity is in correlation with Light intensity measurement (more light - brighter, less light - darker).

Actual room temperature (0.5 °C resolution) and humidity (1 % resolution) is shown on the screen if enabled.

LCD Display “SET mode”

First press on any TB will activate the display to “set mode” and LCD intensity will be put to maximum. No action regarding the pressed TB is done. Further pressings on any TB will make the change(bar-graphs) regarding the pressed TB.

Actual temperature set-point (regarding the right bar-graph) is shown on the screen if enabled.

Display will return to “stand-by mode” if touch buttons are not pressed for a while (~5 seconds).

Changing operation modes

Request for switching between CP *normal* and *economic* operating mode is done with lower left and right TB pressed simultaneously : switch to *economic* mode

Request for switching between CP *on* and *off* operating mode is done with upper left and right TB pressed simultaneously : CP switched *off*

Confirmation of above requested modes is done by Modbus RTU Master equipment by changing the appropriate command bit (normal/economic, system on/off).

Normal

This is default mode for MP1H module. The control algorithm is executing regarding the parameters.

Economy

If set, controller will start cooling when room temperature will raise above max. temperature set-point (SP) and stop when temperature will drop 1 °C below max. temp. SP. On the other hand, when room temperature fall's below min. temp. SP controller will start heating and stop when temperature will raise 1 °C above min. temp. SP.

In economic mode “ECO” sign appear on LCD.

Off

In this mode panel sends command to switch off all devices: hot valve, cold valve, fan. Temperature LCD bar becomes white and “OFF” sign appear on LCD.

CP can be turned off using *fan* TB or *System On/Off* command. In this case cool, heat and fan commands are switched off. Cool and heat commands are also switched off when temperature measured by the panel is inside temperature dead band values (default dead band is 0.5 °C).



Error

In case of CP internal or communication fault, “ERR” sign appear on LCD.

Set

When any of four buttons is pressed more than certain time, “SET” sign appear on LCD and buttons functioning is enabled. After “SET” sign is off, push buttons functions are disabled.

4.2 Functions

PI controller

Output variable range is 0 to 10000 (0 .. 100 %) in heating and/or cooling mode respectively .

Values are used for analog/digital (0 .. 100 % / I.,II.,III. speed) output reference for the fan speed and/or the output for the heat/cool actuator (0 .. 100 % / On-Off valve).

The dynamics of PI calculation is defined by P& I parameters.

Example:

If proportional - P parameter (default = 25) is set to 1 and difference between measured temperature and temperature set point is changed to +1 °C, the PI output value will change from example 5000 to 5100. On the other hand if the difference is changed to -1 °C, PI output value will change from example 5000 to 4900.

If integral - I parameter (default = 5) is set to 1 and difference between measured temperature and temperature set point is +1 °C, the PI output value will increase every second by 1. On the other hand if the difference is -1 °C, the PI output value will decrease every second by 1.

2/4 pipe system selection

While 4-pipe (factory default) system active, controller will activate hot water actuator when heating is required and cool water actuator when cooling is required.

In case 2-pipe system is active, hot water actuator will be operated regardless whether heating or cooling is needed. Mode of operation (closing, opening) is dependent on *Winter/Summer* parameter.

Example:

System selected is 2-pipe , summer mode active and SP is lower than room temperature. CP will start cooling with activating heat valve. In 2-pipe system cool valve is always inactive.

Frost protection

Function activates heat command when room temperature measured by the panel drops below 7 °C. This function has priority over all control panel integrated functions.

Window open

Panel will operate in special mode if opened window and opened balcony door are detected. This function is enabled by enabling parameters *Balcony door En.* or *Window En.* When this function is active and one of parameters *Window* or *Balcony Door* commands is active, fan will stop and valves for heating and cooling will close (delay of 1 minute is add with Balcony door command).



4.3 Parameters

If parameter is set to logical “1”, is considered to be active, enabled or set. If parameter has logical value “0” is considered to be inactive, disabled, or cleared.

Parameter can be status or command or both. When parameter is marked as status this means that module is sending information to controller. On the other hand command represents request from module to Modbus RTU Master equipment.

Communication: Normal state is “1”. If off, there is communication error or no communication established.

Normal/Economic: When set Economic mode is enabled. Default value is “0” therefore normal mode is selected.

Local/Remote: When “0”, Local mode is selected. In this mode CP uses set point set by TB.
In remote mode, “1”, CP uses set point received from other devices (HMI, Touch Panel, OT1, ...) through communication channel.

Heat valve: When valve is opened “1” is reported, while “0” stands for closed valve

Cool valve: When valve is opened “1” is reported, while “0” stands for closed valve

System On/Off: If parameter is set to “0” CP functions are executing in normal mode. If set to “1” Fan speed and all valves are OFF (closed).

Winter/Summer: Used only for two-pipe system to change calculation for Hot valve and Fan speed; Winter - heating (“0”) to Summer - cooling (“1”)

4/2 pipe: Four-pipe system manages hot and cold water pipes simultaneously. Two-pipe system manages only one pair of pipes (one valve, pump). Operation in two-pipe system is therefore dependent on *Winter/Summer (Change-over)* parameter.

“0” = Four pipe system

“1” = Two pipe system

Fan speed I.: When this parameter is “1”, actual fan speed is I.

Fan speed II.: When this parameter is “1”, actual fan speed is II.

Fan speed III.: When this parameter is “1”, actual fan speed is III.

Fan speed mode : This parameter determines fan speed adjustment mode:

“0”: Manual

“1”: Auto

Balcony door En.: When switch for detecting opened balcony door is connected to the system, this function should be enabled (“1”).

Balcony door switch: Parameter reports whether door are closed or opened

“1”: closed

“0”: opened

Window En.: When switch for detecting opened window is connected to the system, this function should be enabled (“1”).

Window switch: Parameter reports whether window is closed or opened

“1”: closed

“0”: opened

Max. temp.: denotes max. SP temp. which is scaled to top of LCD temperature bar

Min. temp.: denotes min. SP temp. which is scaled to bottom of LCD temperature bar

P regulation par.: Proportional parameter for PI calculation algorithm on CP



I regulation par.: Integral parameter for PI calculation algorithm on CP

PI Dead band: Value of change for PI loop output.

Fan reference: denotes fan speed value requested by panel

Temp. SP: This value is taken into PI calculation algorithm

Room temp.: Room temperature measured by CP panel.

Auxiliary room temp.: Room temperature value from other sensor is taken into PI calculation as room temperature instead of temp. value measured by CP panel.

Absolute PI out: Result of PI calculation algorithm used for fan speed and valve opening

Light intensity: Actual light intensity measured by sensor on CP

Min. light intensity: When *Light intensity* is lower than this parameter, LCD bar graph on CP turns off

Remote temp. SP: When *Local/Remote* parameter is active this parameter is taken into PI calculation algorithm as SP.

Fan mode set: Fan mode on CP panel can be remotely changed by Modbus RTU Master equipment. [0,1,2,3,4=Off,I.,II.,III.,auto]. The change is made by setting the *Fan Remote Cmd.* command bit.

Remote Fan mode inc: When this command changes to active, Fan mode on CP panel will be changed in increment-rotate way [->Off,I.,II.,III.,auto,->].

SP up: When this command changes to active, CP will increment SP for 1/10 of scale. It acts like pressing on *Warmer TB* on CP.

SP down: When this command changes to active, CP will decrement SP for 1/10 of SP range. It acts like pressing on *Cooler TB* on CP.

Real Time clock: Real time clock (HH:MM) value by Modbus RTU Master equipment for display on CP panel. Displaying is enabled with *RTC Enable* command bit.

Fan DB Off: If this command is active, the Fan speed inside dead-band goes to Off. Otherwise it remains in low speed.

Temp. display Enable: If this command is active, displaying of actual Room temperature on the CP panel is enabled.

TB pressed: This parameter indicates that any of TB is pressed.



4.4 Modbus RTU variables memory

Table 2: Coils			
Memory	Variable description	Range	Values
00001	Fan in Dband Off Command	0/1	Fan On/Fan Off
00002	Normal/Economy command	0/1	Normal/Economy
00003	Local/Remote command	0/1	Local/Remote
00004	Setpoint DOWN command	0/1	0/DOWN
00005	Setpoint UP command	0/1	0/UP
00006	System ON/OFF command	0/1	ON/OFF
00007	Winter / Summer command	0/1	Winter/Summer
00008	4/2 pipe System command	0/1	4 pipe/2 pipe
00009	Temp. Display Num Enable	0/1	Disable/Enable
00010	RTC Display Num Enable	0/1	Disable/Enable
00011	Fan Mode Increment Command	0/1	0/Led Up
00012	Fan Local/Remote Command	0/1	Local/Remote
00013	Balcony door status	0/1	Open/Closed
00014	Setpoint Display Only Enable	0/1	Disable/Enable
00015	Enable Balcony Door cmd.	0/1	Disable/Enable
00016	Unit °C / °F	0/1	°C / °F

Table 3: Holding Registers			
Memory	Variable description	Range	Values
40001	Max. Temp. Set par. [0.01°]	0 .. 10000	0.00 to 100.00 °C
40002	Min. Temp. Set par. [0.01°]	0 .. 10000	0.00 to 100.00 °C
40003	P regulation parameter	0 .. 100	0 .. 100
40004	I regulation parameter	0 .. 100	0 .. 100
40005	PI Deadband par. [0.01°]	0 .. 10000	0.00 to 100.00 °C
40006	Min.Light Intensity par. [%]	0 .. 100	0 .. 100 %
40007	Remote Temp. Setp. [0.01°]	0 .. 10000	0.00 to 100.00 °C
40008	Fan Mode Set [Off,I.,II.,III.,Auto]	0 .. 4	Off,I.,II.,III.,Auto
40009	Real Time Clock Set Value	0 .. 23:0 .. 59	0 .. 23:0 .. 59
40010	Remote Temperature [0.01°]	0 .. 10000	0.00 to 100.00 °C



Table 4: Digital Inputs

Memory	Variable description	Range	Values
10001	Communication status	0/1	Error/OK
10002	Normal/Economy status	0/1	Normal/Economy
10003	Local/Remote status	0/1	Local/Remote
10004	Heat Valve status	0/1	Closed/Open
10005	Cool Valve status	0/1	Closed/Open
10006	System ON/OFF status	0/1	ON/OFF
10007	Winter / Summer status	0/1	Winter/Summer
10008	4/2 pipe System status	0/1	4 pipe/2 pipe
10009	Fan Speed I status	0/1	0/Speed I
10010	Fan Speed II status	0/1	0/Speed II
10011	Fan Speed III status	0/1	0/Speed III
10012	Fan Local/Remote Status	0/1	Local/Remote
10013	Fan mode Manual/Auto	0/1	Manual/Auto
10014	PushButton Pressed Status	0/1	Off/On
10015	Enable Balcony Door sts.	0/1	Disable/Enable
10016	Enable Window status	0/1	Disable/Enable

Table 5: Input Registers

Memory	Variable description	Range	Values
30001	Max. Temp. Set val. [0.01°]	0 .. 10000	0.00 to 100.00 °C
30002	Min. Temp. Set val. [0.01°]	0 .. 10000	0.00 to 100.00 °C
30003	P regulation par.status	0 .. 100	0 .. 100
30004	I regulation par.status	0 .. 100	0 .. 100
30005	PI Deadband par. [0.01°]	0 .. 10000	0.00 to 100.00 °C
30006	Fan reference	0 .. 10000	0 .. 100.00 %
30007	Temp. Setpoint [0.01°]	0 .. 10000	0.00 to 100.00 °C
30008	Act. Room Temp. [0.01°]	0 .. 10000	0.00 to 100.00 °C
30009	Relative Humidity	0 .. 100	0 .. 100 %
30010	Act. Light intensity [%]	0 .. 100	0 .. 100 %



4.5 Modbus RTU settings memory

Table 6: Holding Registers			
Memory	Variable description	Range	Values
40090	EEProm Write Command ²	0/12345	0 -> 12345 = EEPROM Write
40091	Not used		
40092	Not used		
40093	Not used		
40094	Not used		
40095	Temperature Offset	-1000 .. +1000	-10.00 to 10.00 °C
40096	Touch button Off sensitivity limit	1 .. 20	High sens. .. Low sens.
40097	Touch button On sensitivity limit	1 .. 20	High sens. .. Low sens.
40098	Modbus RTU slave address	1 .. 255	Default address is 1
			0 = 19200 bps (default)
			1 = 600 bps
			2 = 1200 bps
			3 = 2400 bps
			4 = 4800 bps
			5 = 9600 bps
			6 = 14400 bps
			7 = 19200 bps
			8 = 38400 bps
			9 = 56000 bps
			10 = 57600 bps
			11 = 115200 bps
			Other = 19200 bps
			0 = None
			1 = None
			2 = Odd
			3 = Even (default)
			Other = None
40099	Modbus RTU Baud rate NOTE: polling cycle faster than 500 ms can cause occasionally timeout warnings.	0 .. 11	
40100	Modbus RTU Parity	0 .. 3	

² On change from 0 to 12345 the RTU settings memory (40091..40100) will be updated into the module EEPROM.



5 INSTALLATION

5.1 Connection scheme

Figure 2: Connection scheme

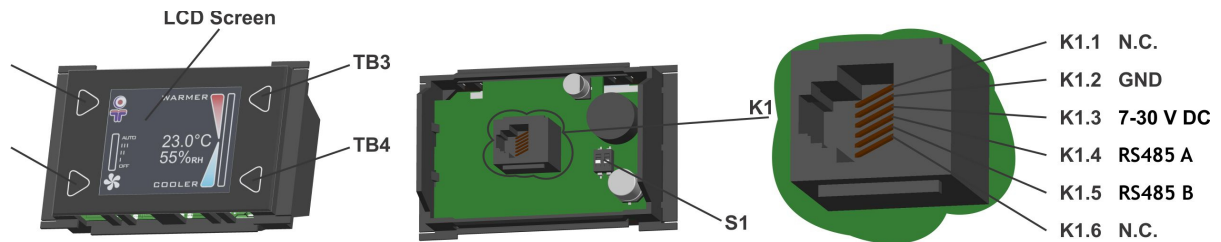
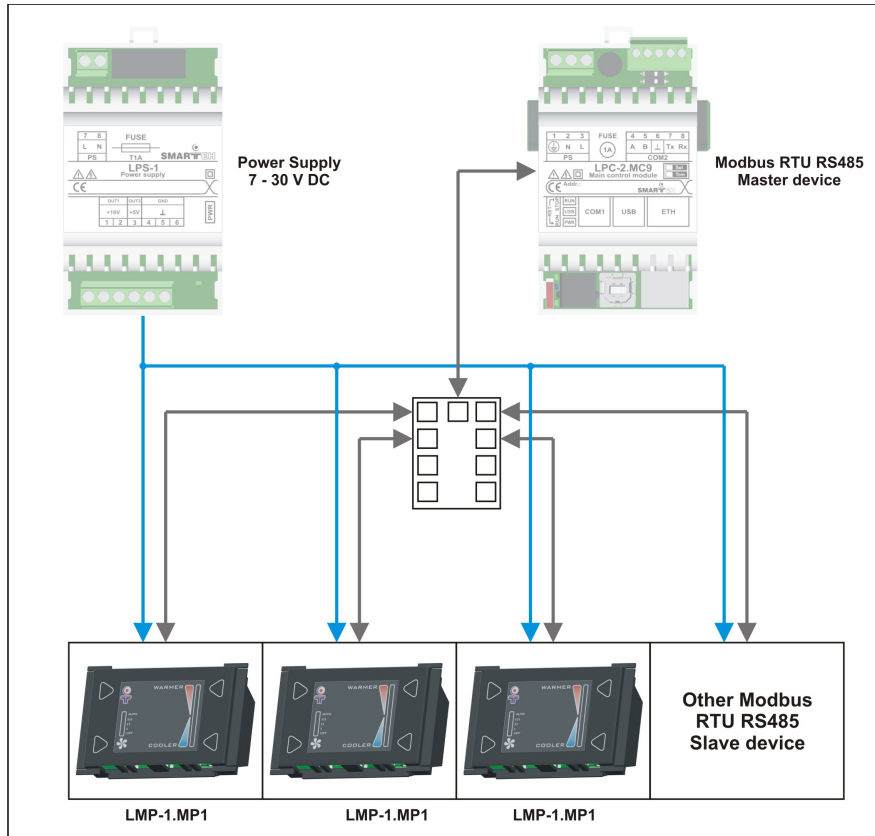

K1.1	N.C.	Not connected
K1.2	GND	Ground
K1.3	7 .. 30 V DC	Power supply input
K1.4	Standard RS-485 A	Data receive/send line A
K1.5	Standard RS-485 B	Data receive/send line B
K1.6	N.C.	Not connected

Bar 1 LCD	Temp. SP	Active LCD bar presents actual set point relative to range <i>Min. temp.</i> (bottom LCD bar) and <i>Max. temp.</i> (top LCD bar)
Bar 2 LCD	Fan mode	I: minimum speed selected II: middle speed selected III: maximum speed selected AUTO: auto speed selection OFF: module functions switched-off
TB1 (Up-left)	Fan mode	Increase Mode & speed selection
TB2 (Down-left)	Fan mode	Decrease Mode & speed selection
TB3 (Up-right)	Temp. SP Up	Increase by one step, step = $(Max. temp - Min. temp) * 1/10$
TB4 (Down-right)	Temp. SP Down	Decrease by one step, step = $(Max. temp - Min. temp) * 1/10$

MODBUS RTU SETTINGS SOURCE	Switch 1	Switch 2
User settings, from Modbus RTU registers	OFF	OFF
Not used	OFF	ON
Not used	ON	OFF
Default factory settings active, 19200 bps/8 data bits/1 stop bit/EVEN	ON	ON

3 Reset LMP-1 module after switch S1 changed, to activate new settings.



5.2 Mounting frame selection

SmarteH has verified following lines to be compatible with LMP-1.MP1H module:

- Bticino - Living, Light
- Gewiss - Playbus, System
- Vimar - Plana, Idea
- Tem - Modul Soft, Modul Line
- Master

Frames of other vendors most probably suits as well, but they were not verified by SmarteH. Before installation verify compatibility of non listed frames.

Module housing has a fin on each side, which can be easily removed with knife cutter or pliers. This adaptation enables housing to be build in various frame formats with two different depths. With regard to frame used you may remove fin for housing to fit in.

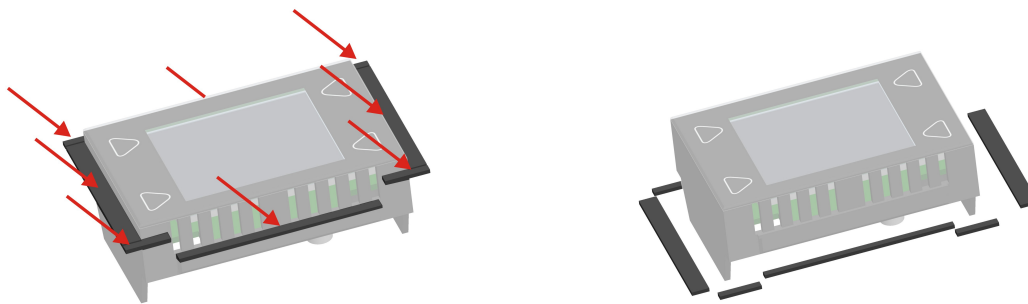
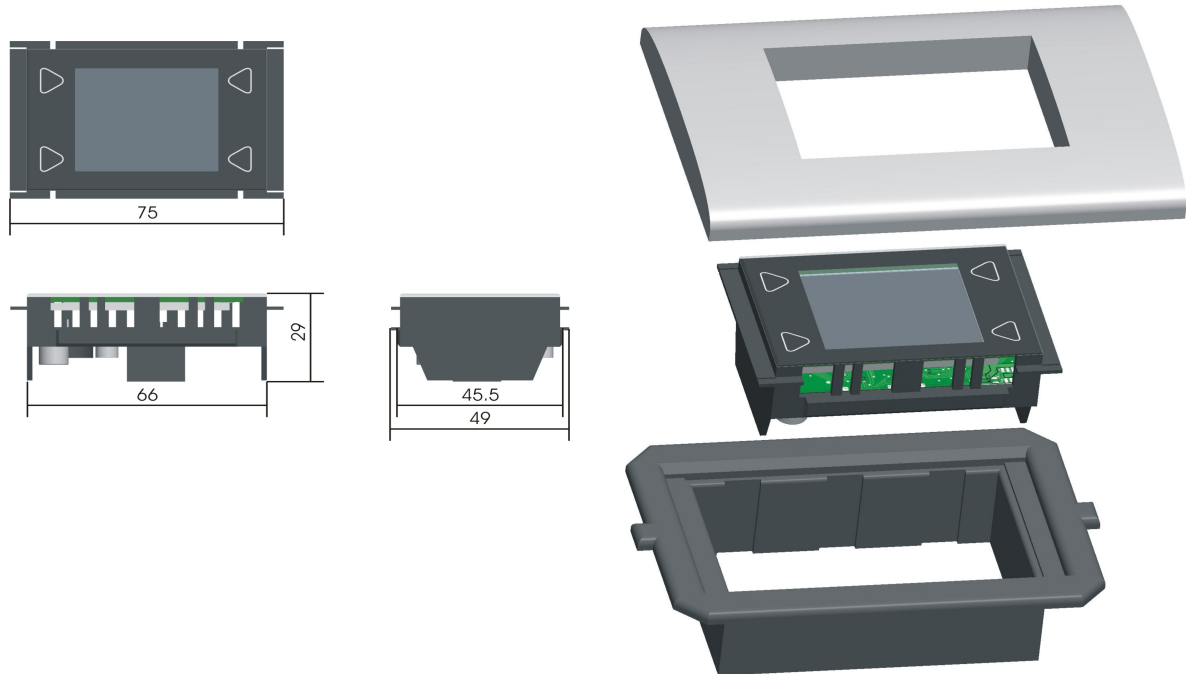

Figure 3: MP1H module with removable fin.



5.3 Mounting instructions

Figure 4: Housing dimensions



Dimensions in millimeters.



All connections, module attachments and assembling must be done while module is not connected to the main power supply.
 Module should be positioned in the wall inside of the room. Avoid direct sunlight or positioning near heating/cooling source object.
 Recommended installation height is 1.5 m above floor level.

1. Set the correct LMP-1.MP1H settings (refer to Table 6 and Table 9).
2. Connect LMP-1.MP1H with appropriate cable to the connector K1, Modbus RTU Master equipment and power supply source (refer to Table 7). Max. allowed tensile force is 30 N.
3. Put the LMP-1.MP1H in mounting frame
4. Cover LMP-1.MP1H with cover plate

Modbus RTU settings source is set with DIP switch on the back of the LMP-1.MP1H module (Table 9).

NOTE: Signal wires must be installed separately from power and high voltage wires in accordance with general industry electrical installation standard.



5.4 Module labeling

Figure 5: Labels

Label 1:

LMP-1.MP1H
 P/N:220MP151V01001
 D/C: 40/11

Label 2:

S/N: MP1-S9-1100000003

Label 1 description:

1. **LMP-1.MP1H** is the full product name.
2. **P/N: 220MP151V01001** is the part number.
 - **220** - general code for LPC-2 product family,
 - **MP1** - short product name,
 - **15** - year of code opening,
 - **V** - denotes flush frame mounting module,
 - **01** - derivation code,
 - **001** - version code (reserved for future HW and/or SW firmware upgrades).
3. **D/C: 40/11** is the date code.
 - **40** - week and
 - **11** - year of production.

Label 2 description:

1. **S/N: MP1-S9-1100000003** is the serial number.
 - **MP1** - short product name,
 - **S9** - user code (test procedure, e.g. Smarteh person xxx),
 - **11** - year (last two cyphers),
 - **00000003** - current stack number; previous module would have the stack number 00000002 and the next one 00000004.



6 REGULATION DIAGRAM

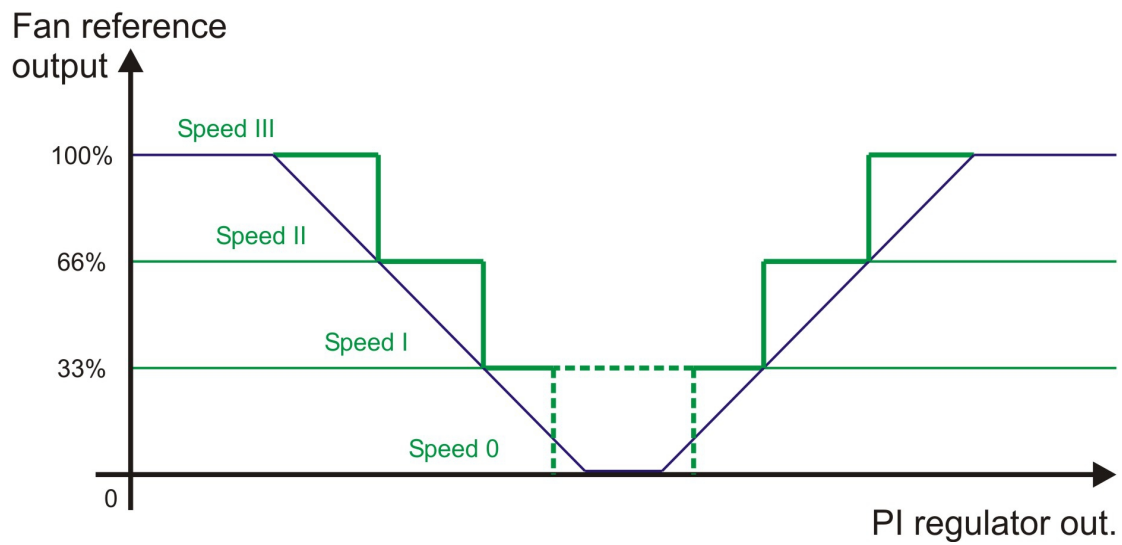
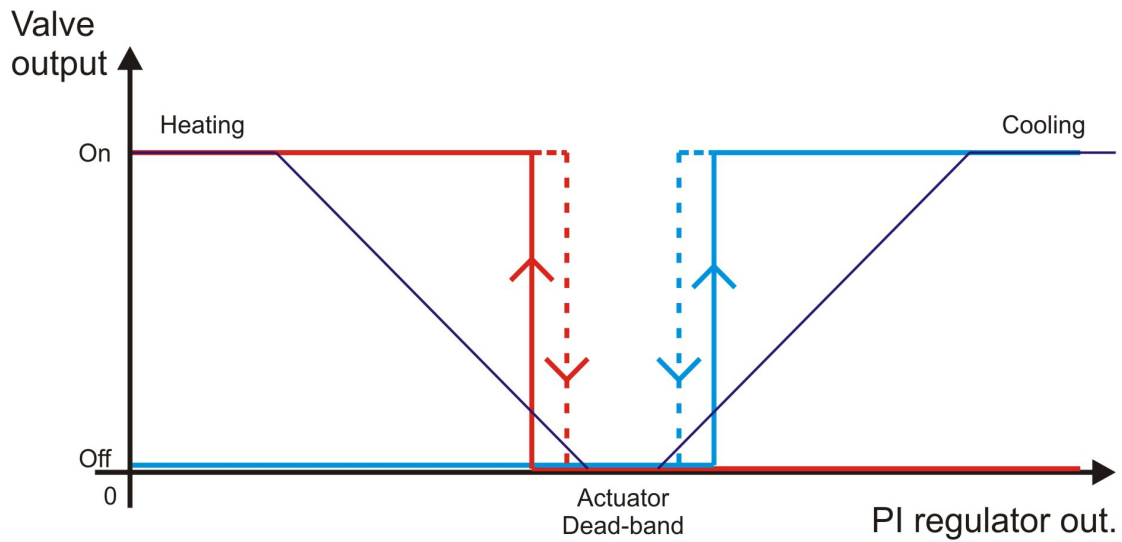
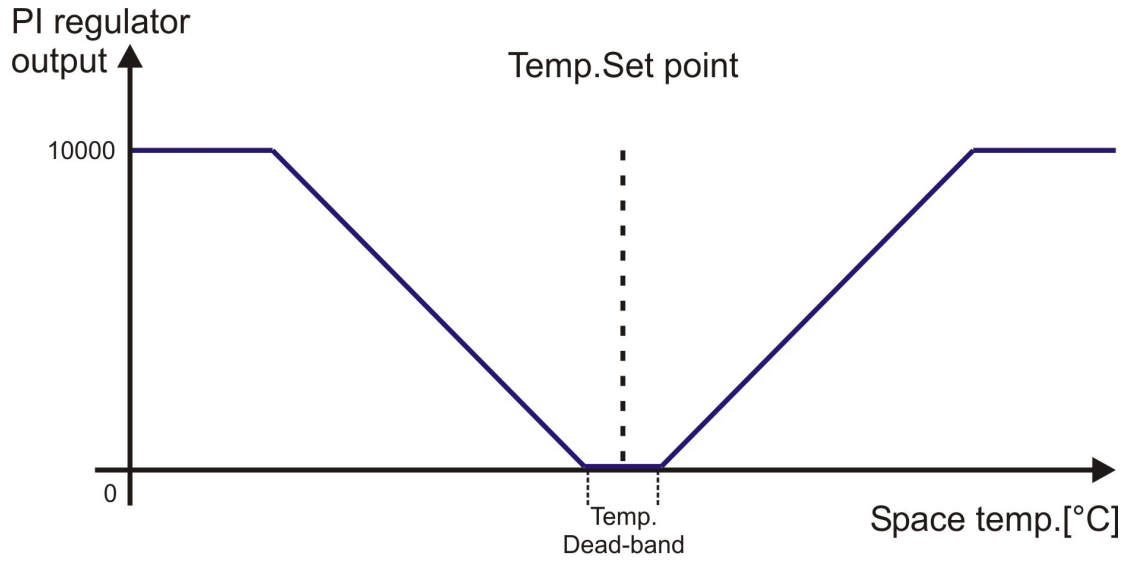

7 TECHNICAL SPECIFICATIONS

Table 10: Technical specifications

Power supply	7 .. 30 V DC from an external source
Interconnection connector type	RJ-12 6/6
Power consumption	1 W
Dimensions (W x H x D)	75 x 49 x 29 mm
Weight	50 g
Maximum altitude	2000 m
Mounting position	horizontal
Ambient temperature	0 to 50 °C
Ambient humidity	max. 95 %, no condensation
Transport and storage temperature	-20 to 60 °C
Protection class	IP 20





8 CHANGES

The following table describes all the changes to the document.

Date	V.	Description
------	----	-------------





9 NOTES



