

5 3 1



5 3 1

PLC, DCS, PC CONTROL BACKUP STATION
USER'S MANUAL

 [®]
**MOORE
INDUSTRIES**

	page
CONTENTS	
FIGURE LIST	iii
CHAPTER 1	
INTRODUCTION	1
Conforming What Is Included	1
Order Code	2
Basic Operation	3
Where To Go Next	3
Text Formatting in This Manual	3
CHAPTER 2	
INTERFACE & BASIC OPERATION	5
Displays	5
Icons	5
Keys	6
Basic Operating Procedures	7
Alarms	8
CHAPTER 3	
HARDWARE CONFIGURATION	9
Accessing and Changing Jumpers	11
Adding or Changing Output Modules	12
Where to Go Next	13
CHAPTER 4	
MOUNTING AND WIRING	15
System Planning	15
Mounting the Station	15
Wiring the 531 Inputs	16
A. AC Power	17
B. Process Variable	17
C. Digital Inputs	18
D. Remote Setpoint Indicator	19
Wiring the 531 Outputs	19
A. CV Output	19
B. Mechanical Relay Output	19
C. Solid State Relay (Triac) Output	19
D. DC Logic (SSR Drive) Output	19
Wiring for Serial Communications	20
Where to Go Next	20
CHAPTER 5	
SOFTWARE CONFIGURATION	21
Mode Overview	21
Menus	22
Smart Menus	22
Software Configuration Procedures	23
Guide to Set up Parameters	25
CONFIG.	25
LOCAL OUT.	28
PV INPUT	29
CUST. LINR.	31

About This Manual:

Throughout this User's Manual will appear **NOTES**, **CAUTIONS** and **WARNINGS**, usually in **boldface**. Please heed these safety and good practice notices for the protection of you and your equipment.

Contents

	page
RSP INPUT	32
ALARMS	33
SECURITY	35
SER. COMM.....	36
OPERATION	37
Parameter Value Charts	39
CHAPTER 6	
531 APPLICATIONS	45
531 Operation	45
Alarms	46
Digital Inputs	50
Watchdog Monitor	51
Process Variable and Setpoint	51
Input Linearization	53
Thermocouple and RTD Linearization	53
Square Root Linearization	53
Custom Linearization	53
Ramp to a Control Value	54
Security	55
Process Variable Reading Correction	56
Serial Communications	56
APPENDIX A	
MODE, MENU & PARAMETER FLOWCHART	A-1
APPENDIX B	
PARTS LIST	B-1
APPENDIX C	
TROUBLESHOOTING	C-1
APPENDIX D	
CALIBRATION	D-1
Regarding Calibration	D-1
RTD and VmA Input Calibration	D-2
Thermocouple & Cold Junction Calibration	D-3
Milliamp Output Calibration	D-4
Reset Menu Data	D-4
Hardware Scan	D-5
Quick Calibration Procedure	D-5
APPENDIX E	
SPECIFICATIONS	E-1

Figure	Title	Page
Figure 2.1 531 Operator Interface	5
Figure 2.2 Before and After Acknowledging an Alarm	8
Figure 3.1 Location of Printed Circuit Boards	9
Figure 3.2 Jumper Locations on Microcontroller Board	10
Figure 3.3 The Option Circuit Board	10
Figure 3.4 The Power Supply Circuit Board	10
Figure 3.5 Output Module	13
Figure 4.1 531 Instrument Panel and Cutout Dimensions	15
Figure 4.2 Mounting Brackets	16
Figure 4.3 531 Rear Terminals	17
Figure 4.4 Output Wiring for the 531	19
Figure 4.5 Serial Communications Terminals	20
Figure 5.1 Menu Flowchart for Set Up	21
Figure 5.2 Independent vs. Dependent Parameters	22
Figure 5.3 Keys to Enter and Move Through Set Up Mode	23
Figure 6.1 Alarm Examples	49
Figure 6.2 Square Root Linearization Formula	53
Figure 6.3 Custom Linearization Curve	54
Figure D.1 Flowchart to Access Parts of Calibration Menu Block	D-1
Figure D.2 Microcontroller Circuit Board	D-2
Figure D.3 Calibration Wiring	D-2
Figure D.3a	... Calibration Wiring (continued)	D-3
Figure D.4 Thermocouple & Cold Junction Calibration Wiring	D-3
Figure D.5 Milliamp Calibration Wiring	D-4

CHAPTER 1 INTRODUCTION

The 531 PID Backup Station ensures the integrity of your processes with maximum reliability. Isolated inputs and outputs guard against electrical interference, the front face meets NEMA 4X standards for watertight operation, and the rugged case and sturdy rubber keys enhance durability.

The 531 has three digital display areas, two of which offer up to 9 characters of true alphanumeric. The bright, crisp vacuum fluorescent displays offer better readability than any other display technology. Additional operator friendly features include: custom programmable alarm messages, keys that illuminate when in use, and an easy-to-use menu system.

Thank you for selecting the 531 PID Backup Station. It is the most sophisticated instrument in its class and will provide you with years of reliable, trouble-free performance.

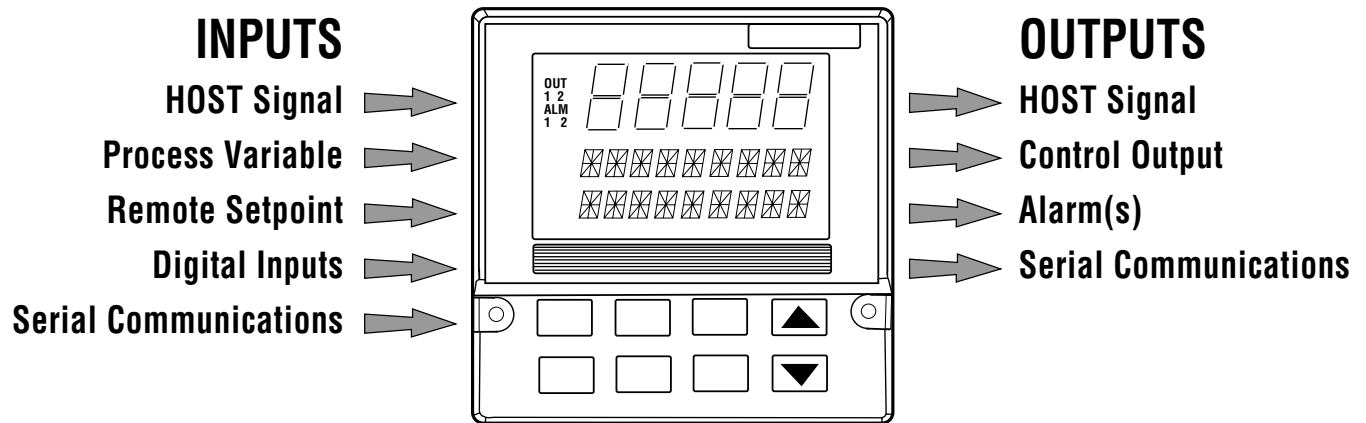

The 531 automatically provides PID backup control for critical control loops. In **Host Mode**, the control signal passes from the Host device through the 531 without any degradation. A Host device may be a PLC, DCS, or process controller. The 531 switches to **Automatic (PID) Mode** upon keypad selection, digital input, or loss of the Host signal, and generates a control signal based on its own PID calculations. The control setpoint may be one or two preset setpoints, or transmitted to the 531. The 531 can also be switched to **Manual Mode**, in which the operator can manually adjust the output. The 531 will transfer/return to **Host Mode** upon keypad selection, opening of the digital input or return of the Host signal.

Note: that the 531 PID Backup Station is *not a point of failure*; removing it from the case or powering down while in Host Mode will *not* disturb the Host signal.

CONFIRMING WHAT IS INCLUDED

With your 531 PID Backup Station, you should have received:

- 1 531 User's Manual
- Mounting hardware set
- 1 sheet of engineering unit adhesive labels
- 1 Terminal label

You can determine the installed outputs of your station by comparing your product number to the Order Code below. The product number is printed on the label on the top of the controller case.

BASIC OPERATION

There are three operating modes for the 531:

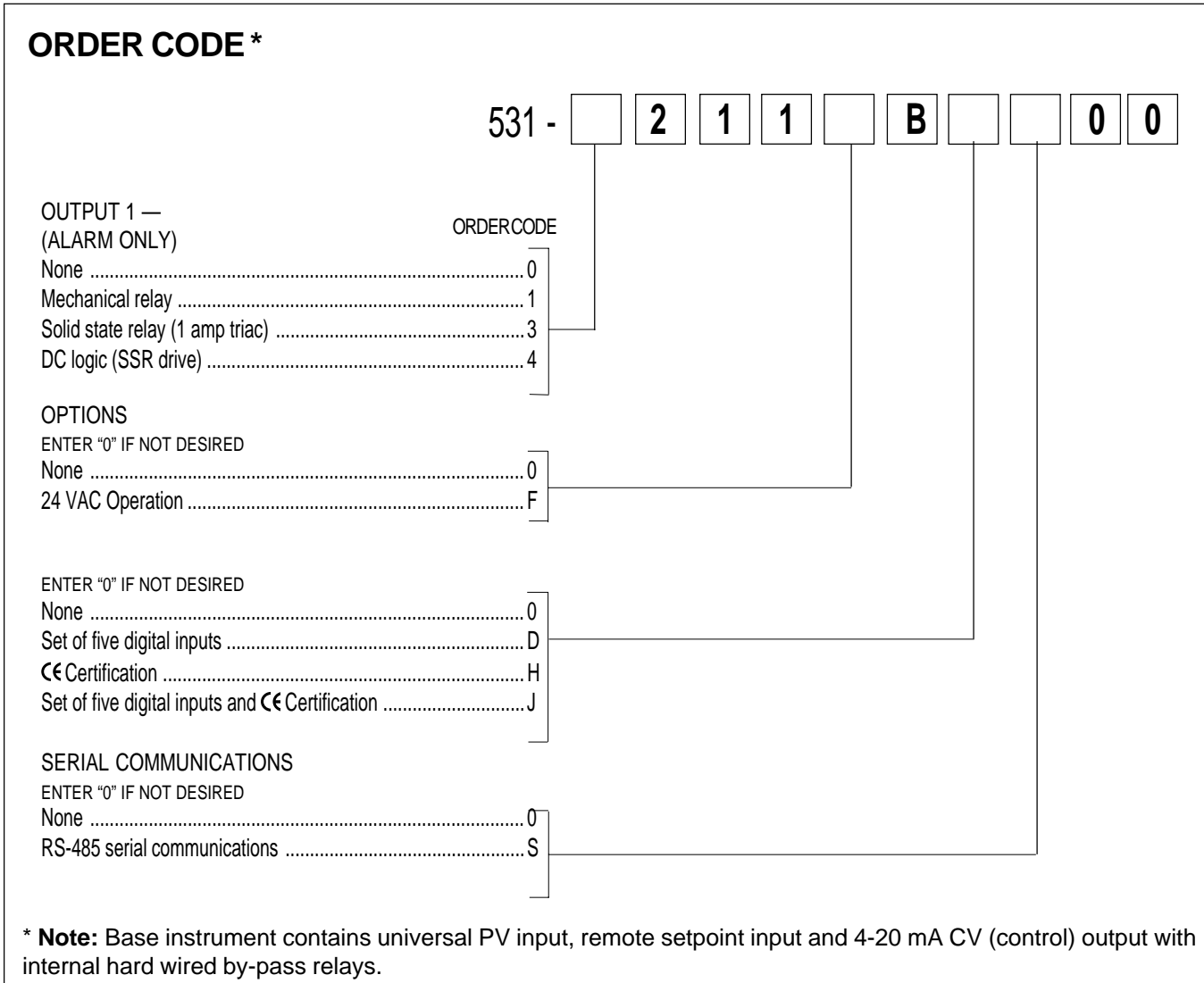

NOTE:

Altering the factory configuration of the modules will render the product label code invalid.

Host Mode: The 531 operates as a remote station that passes a CV directly from a host to a controlled device. In this mode, the SP but not the CV (output) can be altered. Special “set up” parameters can be accessed, and the 531 can be transferred into either of the other operating modes.

Automatic Mode: The 531 sends output to the final device as provided by its own PID calculations. In this mode, the SP but not the CV (output) can be altered. The “set up” parameters may not be accessed, but the 531 can be transferred to either of the other operating modes.

Manual Mode. An operator provides manual output to the controlled device. Both the SP and the CV can be altered, and the 531 can be transferred to either of the other two operating modes.

The 531 also has a set up, or “configuration” mode in which the user configures the special functions of the 531, like inputs and outputs, alarms and PID operation. There are 9 menus in set up mode: eight are for instrument set up, and the ninth, OPERATION, configures the operational aspects of the 531.

WHERE TO GO NEXT

- First time users should read through this entire manual. Continue to Chapter 2 for basic interface and operation information. Then read Chapter 3 for important installation guidelines.
- Experienced users may continue on to Chapter 5 for details on the configuration features of the 531.
- Appendix 1 contains flowchart references for all 531 parameters, menus and modes.

TEXT FORMATTING IN THIS MANUAL

<u>Feature</u>	<u>Format</u>
Mode	Automatic, Manual, Host Mode
KEYS	SET PT DISPLAY or <div style="display: flex; justify-content: center; gap: 10px;"> <div style="border: 1px solid black; padding: 2px 5px;">SET PT</div> <div style="border: 1px solid black; padding: 2px 5px;">DISPLAY</div> </div>
ICONS	OUT, ALM
MENUS	CONFIG., TUNING
PARAMETERS	CYCLE TM:1, MIN.OUT2
PARAMETER VALUES	OFF, SETPOINT, LAST OUT.
DISPLAY MESSAGES	TOO HOT, OUT%,

CHAPTER 2 INTERFACE AND BASIC OPERATION

The individual software and hardware options of your station determine the information it displays. Compare the product number on the unit label to the Order Code in Chapter 1 for more information. A “smart menu” feature of the 531 allows only those messages relevant to your individual hardware (and software) configuration to appear in the displays.

NOTE::

Any modifications to the factory settings of the output modules will alter the Model Number displayed upon power-up from the original the Product Code on the label.

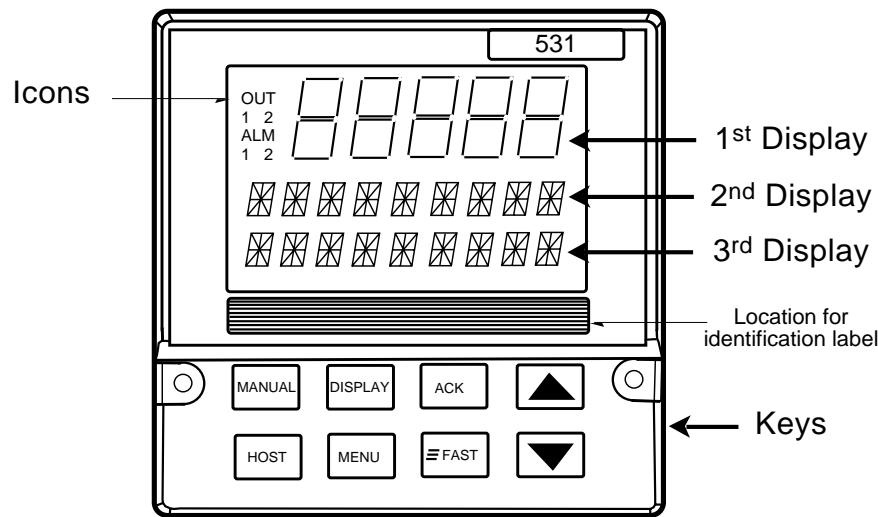

Figure 2.1
531 Operator Interface

1st Display

- 5 digits, seven segments. Height is 15mm (0.6in).
- Normally displays the Process Variable (PV).
If station loses signal, “-----” displays.

2nd Display

- 9 characters, 14 segment alphanumeric. Height is 6mm (0.25in).
- Displays the CV output (OUT) or the setpoint (SP). To change the displayed value, press the DISPLAY key.
- When in configuration menus, displays the menu and parameter names

3rd Display















- 9 characters, 14 segment. Height is 6mm (0.25in).
- Displays user-selectable station name if no alarms are queued.
- Displays any error or alarm in two-second alternating messages.
- When in configuration menus, displays the parameter values.

ICONS:

ALM 1, ALM2: Indicates respective alarm(s) is/are active.

OUT 1, OUT2: Indicates respective output(s) is/are active.

ALM 1	ALM 2	ALM 1 2
OUT 1	OUT 2	OUT 1 2

KEYS	Press Key (s)	Illuminated Key
	Transfers station from Host or Automatic Mode to Manual Mode , or from Manual to Automatic .	Station is in Manual Mode. When not illuminated, the station is in either Host or Automatic Mode.
	Toggles between Host and either Automatic or Manual Mode (depending on validity of the PV).	531 is passing Host signal through.
	Exits the configuration (set up) menus and returns station to operating mode.	Key does not light.
	Provides entry into the OPERATION set up menu.	531 is in configuration (set up) mode.
	Acknowledges alarms.	An acknowledgeable alarm exists.
	Functions as a “shift” key or for use with other keys.	Key does not light.
 or 	Increases or decreases the value or selection of the current parameter.	Keys do not light.
 +  or  + 	Changes parameter value or selection at a faster rate.	N/A
 + 	In Host or Manual Mode, provides entry into the other eight set up menus. When under configuration, advances from menu to menu.	N/A

NOTE:

Refer to Chapter 3, or Appendix 1 for details on menu, mode and parameter transitions

BASIC OPERATING PROCEDURES

To transfer from Host to Automatic Mode

1. Press the **HOST** key once. The 531 will transfer to **Automatic Mode** as long as the PV input is valid (else, it transfers to **Manual Mode**).
2. The **HOST** key and **MANUAL** key will be off.
3. The 531 stops passing the Host signal, and transmits its own output that based on PID, with a bumpless transfer.

To transfer from Host to Manual Mode

1. Press the **MANUAL** key. The 531 will transfer to **Manual Mode**.
2. The **HOST** key will extinguish, and the **MANUAL** key will light.
3. The 531 stops passing the Host signal, and transmits a manual output to the final control element. This will be a bumpless transfer.

To transfer from Automatic to Manual Mode

1. When in **Automatic Mode**, press the **MANUAL** key.
2. The **MANUAL** key will light.
3. The 531 stops transmitting the PID output and transmits a manual output to the final control element. This will be a bumpless transfer.

To transfer from Automatic/Manual Mode to Host Mode

1. Press the **HOST** key. The 531 will transfer to **Host Mode** as long as the CV signal is valid (otherwise, it remains in the previous mode).
2. The 531 will stop transmitting its own output (CV) signal, and pass the signal from the Host device to the final control element. This will be a direct transfer.
3. To provide a ramped transfer, the ramping rate (HOST RAMP) can be set in the **OPERATION** menu.

To change output values

1. Press **MANUAL** key to shift to **Manual Mode** from **Automatic** or **Host**.
2. The second display will display OUT%.
3. Use **▲** and **▼** keys to change the output (CV) value.

To override security or reset the controller

1. If someone attempts a locked operation, SECURITY appears in the 2nd display, and a security code prompt (0) appears in the 3rd display.
2. Use **▲** and **▼** keys to select a code value. The value will be entered after two seconds of key inactivity.
 - If no code was entered (value left at 0), SECURITY disappears and the station resumes operation.
 - If the value is incorrect, INCORRECT appears in the 3rd display. After 2 seconds, the station prompts you to enter a new code.
 - If the code is correct, CORRECT appears in the 3rd display. After two seconds, all displays clear and you have temporary access to all previously locked features. Security will automatically rearm (lock) the station once after one minute of key inactivity.
 - If the correct **Security Override Code** is entered, RESET appears in the 3rd display. After two seconds, all displays clear and the stations functions are reset to their factory defaults (unlocked).

NOTE:

For more information on operating modes, see Chapter 6.

NOTE:

For more information on Security functions, see Chapter 6.

NOTE:

Powering down the controller acknowledges/clears all latched alarms. When powering up, all alarms will be reset according to their power-up configuration (see Chapter 6).

NOTE:

All alarms are internal alarms unless tied to an output relay in the set up mode.

ALARMS

IMPORTANT! Alarms can be used to provide warnings of unsafe conditions. Therefore, all 531 operators must know how the alarms are configured, how to react to alarm conditions, and the consequences of acknowledging (noting and clearing) an alarm.

The 531 indicates alarms by:

- Lighting icons
- Displaying messages; and
- Lighting the **ACK** key, if an alarm is in an acknowledgeable state.

To acknowledge an alarm:

1. Press the **ACK** key to acknowledge Alarm 1. This clears the alarm (and releases the relay, if applicable).
2. Both the icon and message indicators disappear, and the relay (if applicable) changes state.
3. If a second alarm is active and acknowledgeable, press the **ACK** key again to acknowledge Alarm 2.

Figure 2.2 shows the controller face during an alarm condition, and after the alarm has been acknowledged.

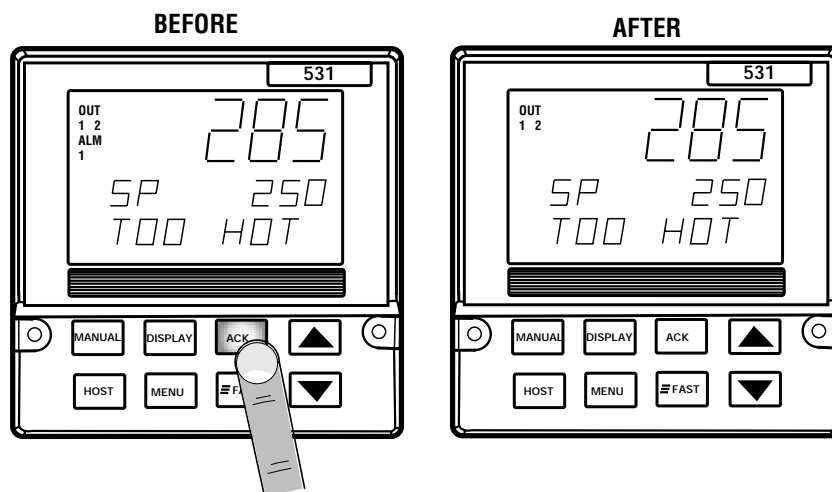

Figure 2.2
Before and After Acknowledging
an Alarm

Latching Alarms

A **latching** alarm holds its alarm state even after the process leaves the alarm condition. This is useful for stations that will not be continuously monitored by an operator. A latching alarm can be configured to be acknowledgeable while in the alarm condition, OR only after the process leaves the alarm condition. A **non-latching alarm** will clear itself as soon as the process leaves the alarm condition.

Limit Sequence

An alarm can be configured to be **both** latching and not acknowledgeable. In this case, the alarm is acknowledgeable only after the process has left the alarm condition. This is often referred to as a **limit sequence**.

For more on alarms, see Chapter 6.

CHAPTER 3 HARDWARE CONFIGURATION

The 531 hardware configuration determines which outputs are available and the types of indicator signals that will be used.

Your station comes factory set with the following:

- All the specified modules and options installed (see product label and compare to Order Code in Chapter 1).
- Process variable and remote setpoint inputs set to accept a milliamp input.

NOTE:

If you would like your controller configured at the factory, please consult an application engineer.

CAUTION!

Static discharge will cause damage to equipment. Always ground yourself with a wrist grounding strap when handling electronics to prevent static discharge.

NOTE:

Your hardware configuration will influence the available set up options in Chapter 5.

- Relay outputs set to normally open

The locations of certain jumpers and modules on the printed circuit boards will allow different types of inputs and outputs to be connected to the stations. Figure 3.1 shows the position of these circuit boards inside the station. To access these boards:

1. With power off, loosen the two captive front screws with a Phillips screwdriver.
2. Gently slide the chassis out of the case by pulling on the front face plate assembly at the bezel. Remove the two screws.

NOTE:

Any changes you make to the output modules will render the code on the product label invalid.

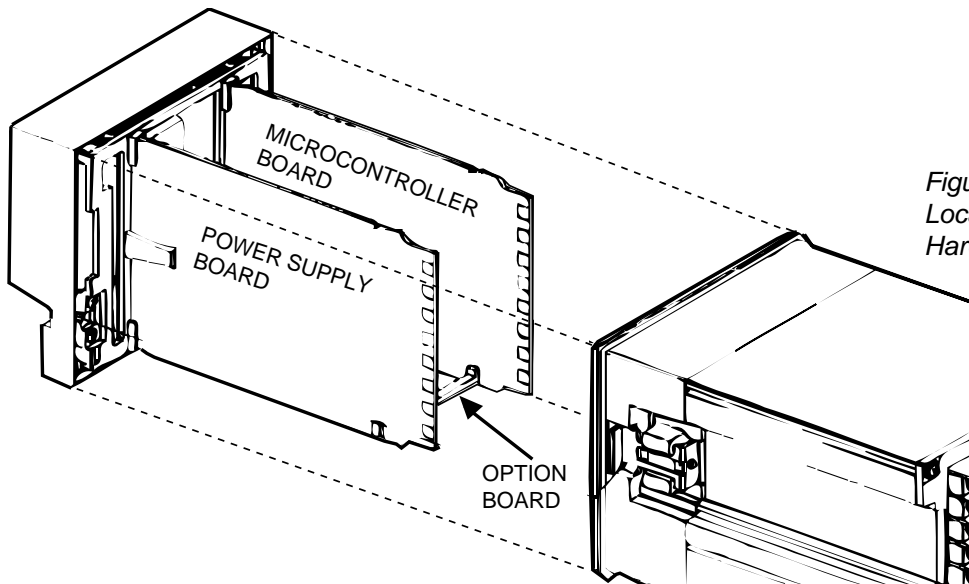

Figure 3.1
Location of Printed Circuit Boards for
Hardware Configuration

Process Variable Indicator Type

The 531 will accept several different types of Process Variable Signals. You specify the type of signal by adjusting the PV **jumper location** on the Microcontroller Circuit Board, as shown in Figure 3.2. You will also need to set the particular sensor range in the software (Chapter 5).

V	Voltage signal
MA	Milliamp
TC t	Thermocouple with downscale burnout
TC s	Thermocouple with upscale burnout
RTD	RTD

Figure 3.2
Jumper Locations on
Microcontroller Board

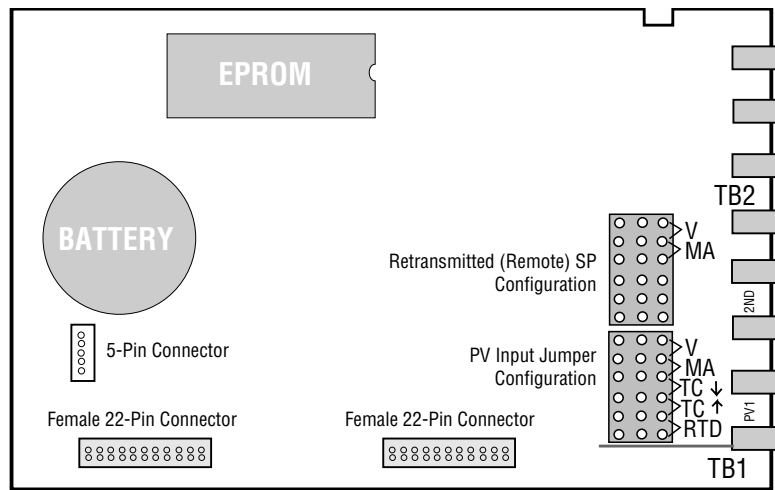
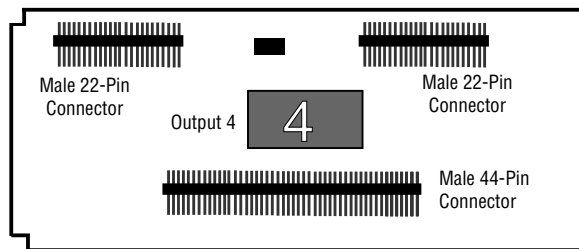
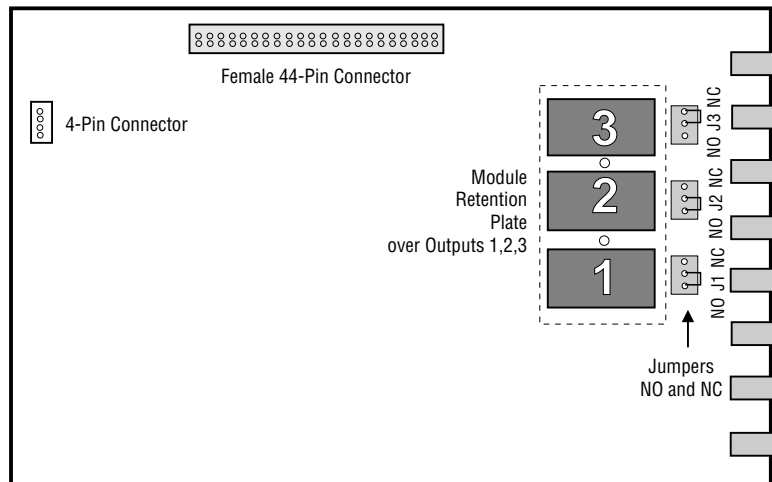

Figure 3.3
The Option Circuit Board, with Output 4



CAUTION!!
Do not change configuration of outputs 2, 3, and 4. Do not change position of jumpers J2 and J3.

Figure 3.4
The Power Supply Circuit Board,
with Outputs 1 through 3



Setpoint Type (retransmitted)

You specify the type of retransmitted setpoint by adjusting the **jumper location** on the Microcontroller Board, as shown in Figure 3.2:

V	Voltage signal
MA	Milliamp signal (factory default)

Mechanical Relays

There is one **output module** socket on the Option Board (Figure 3.3), and three on the Power Supply Circuit Board (Figure 3.4). The position of the jumper next to each socket determines whether the relay is configured for Normally Open (NO) or Normally Closed (NC). The output on the options board is always factory set to Normally Open (NO).

Only the Output 1 relay (if used) may be configured for normally open or normally closed. **Do not** make any changes to J2 and J3.

ACCESSING AND CHANGING JUMPERS

Jumper connectors either slip over adjacent pins, or have pins which insert into adjacent holes. “Changing the jumper” means moving the jumper connectors to alternate pins/holes.

Equipment needed:

- Needle-nose pliers (optional)
 - Phillips screwdriver (#2)
 - Wrist grounding strap
1. With power off, loosen two captive front screws with a Phillips screwdriver.
 2. Slide the chassis out of the case by pulling on front face plate assembly at the bezel. Remove the two screws now. You will not need to disassemble the chassis to make these adjustments.
 3. Refer to Figures 3.2 and 3.4 to locate the jumper connector you want to change.
 4. With either your fingers or the needle nose pliers, pull the jumper connector straight up, being careful not to bend the pins (see Photo 4)
 5. Move the jumper connector over the desired location and press it straight down, making sure it is seated firmly. Repeat steps 3 and 4 for any other jumpers you wish to change.
 6. When you are ready to reassemble the unit, align the boards on the chassis with the case's top and bottom grooves. Press firmly to slide the chassis into the case. If you have difficulty, check that you have properly oriented the chassis and that there are no screws interfering with the case.
 7. Carefully insert and align screws. Tighten them until the bezel is seated firmly against the gasket. **Do not overtighten.**

CAUTION!!

Static discharge will cause damage to equipment. Always ground yourself with a wrist grounding strap when handling electronics to prevent static discharge.

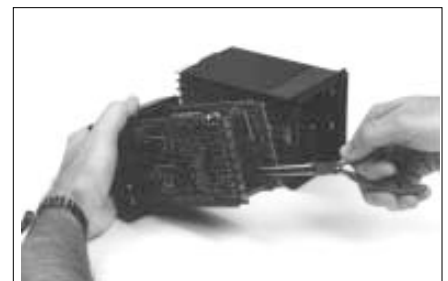

4. REMOVE JUMPERS

CAUTION!!

Static discharge will cause damage to equipment. Always ground yourself with a wrist grounding strap when handling electronics to prevent static discharge.

ADDING OR CHANGING OUTPUT MODULES

The 531 has provisions for four output modules. The units come factory configured with specified modules installed in appropriate locations. You can make field adjustments by properly removing and/or plugging the modules into the appropriate sockets.

Important Notes:

- Only the Output 1 relay (if used) may be changed.
- Output modules 2, 3 and 4, and Jumpers J2 and J3 **must not be changed** from their factory installation.
- Any output module with a sold state relay or analog module **MUST** have its jumper set at normally open (NO).
- Output 4 is always normally open (NO).

Three of the output sockets are located on the Power Supply Circuit Board. A fourth output socket is located on the Option Board.

Equipment needed:

- Wrist grounding strap
 - Phillips screwdriver (#2)
 - Small flat blade screwdriver
 - Wire cutters or scissors
1. With power off, loosen two captive front screws with a Phillips screwdriver.
 2. Slide the chassis out of the case by pulling on front face plate assembly at the bezel. Remove the two screws now.
 3. Locate the retention clips holding the front face assembly to the rest of the chassis. Pry apart these retention clips gently with a screwdriver to separate the printed circuit board group from the front face assembly. Take care not to break the clips or scratch the circuit board. See Photo 3.
The Microcontroller Board and Power Supply Board remain attached to the Operator Interface Assembly by wired connectors.
 4. See Photo 4. The Microcontroller and Power Supply board are attached to either side of the Option board by male/female pin connectors. Use a gentle rocking motion and carefully apply pressure to separate the larger two boards from the Option Board.

CAUTION!

Do not scratch the boards or bend the pins of the connectors.



3. PRY CLIPS

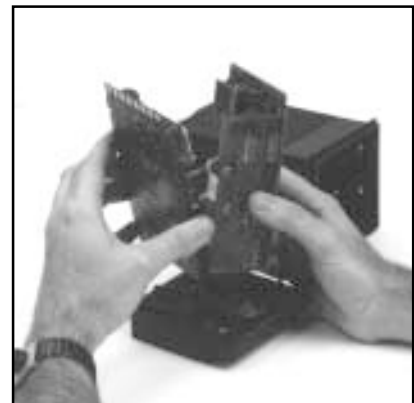

4. SEPARATE BOARDS

5. A retention plate and tie wrap hold Output modules 1, 2, and 3 (on the Power Supply board) firmly in place. To remove the retention plate, snip the tie wrap with wire cutters (or scissors) as shown in Photo 5.

Always snip the tie wrap on top of the Retention Plate to prevent damage to the surface mount components.

6. A disposable tie wrap holds Output module 4 (on the Option board) in place. To remove the module, snip tie wrap like in Photo 6.
7. Inspect each module before installation to make sure the pins are straight (Figure 3.5). Align the pins with the socket holes and carefully insert the module. Press down to seat it firmly on the board (see Photo 7).

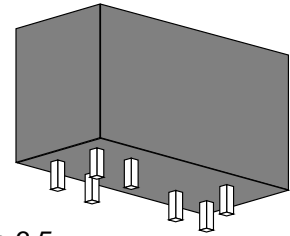
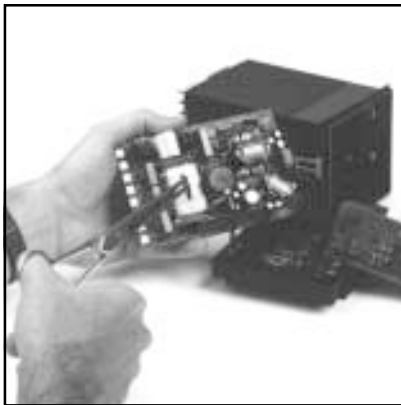

Figure 3.5
Output Module



5. REMOVE RETENTION PLATE



6. SNIP TIE WRAP

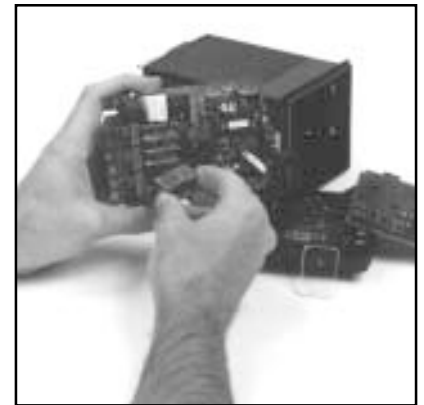

7. ADD/CHANGE MODULE

8. Use new tie wraps to secure the Retention Plate and Output Module 4.
Failure to use the tie wraps may result in the module loosening and eventual failure. All individually ordered modules come with tie wraps. Extra sets of tie wraps are available; order Part #535-665.
9. To reassemble the unit: Align the connector pins on the Option Board with the connector sockets on the Microcontroller and Power Supply boards. Squeeze them together, making certain all three are properly seated against one another. Check along the side edges for gaps. Also, check that the cable assemblies are not pinched.
10. Align the board assembly with the front face assembly, with the Option board at the bottom (see Figure 3.1). Reinstall the retention clips. Align the boards into the slots of the front face assembly and the clips will snap into place.
11. When you are ready to reassemble the unit, align the boards on the chassis with the top and bottom grooves on the case. Press firmly to slide the chassis into the case. If you have difficulty, check that you have properly oriented the chassis, and there are no screws interfering with the case.
12. Carefully insert and align screws. Tighten them until the bezel is seated firmly against the gasket. **Do not overtighten.**

WHERE TO GO NEXT

For a step-by-step guide on mounting and wiring your 531 PID Backup Station, see Chapter 4.

CHAPTER 4

MOUNTING AND WIRING

The 531 PID Backup Station is thoroughly tested, calibrated and “burned in” at the factory, so your station is ready to install. But before you begin, read this chapter carefully and take great care in planning your system. A properly designed system can help prevent problems such as electrical noise disturbances and dangerous conditions.

SYSTEM PLANNING

A. Consider the Noise Factor

- For improved electrical noise immunity, install the station as far away as possible from motors, relays and other similar noise generators.
- Do not run low power (sensor input) lines in the same bundle as AC power lines. Grouping these lines in the same bundle can create electrical noise interference.

B. Wiring Practice Resources

An excellent resource about good wiring practices is the IEEE Standard No. 518-1982 and is available from IEEE, Inc., 345 East 47th Street, New York, NY 10017, (212) 705-7900.

WARNING!

To avoid electric shock, DO NOT connect AC power wiring at the source distribution panel until all wiring connections are complete. To avoid shock hazard and reduced noise immunity for your system, **terminal 9 must be grounded.**

MOUNTING THE STATION

A. Make the panel cutout

The station fits in a standard 1/4 DIN cutout. You may mount your station in any panel with a thickness from .06 to .275 inches (1.5 mm to 7.0 mm). See Figure 4.1 for dimensions.

If you make a mistake in the panel cutout, you can use a “Goof Plate” (Repair Part #512-014).

B. Establish a waterproof seal

The station front face (keys, display, and bezel) are NEMA 4X rated (waterproof).

Figure 4.1
531 Instrument Panel and Cutout
Dimensions

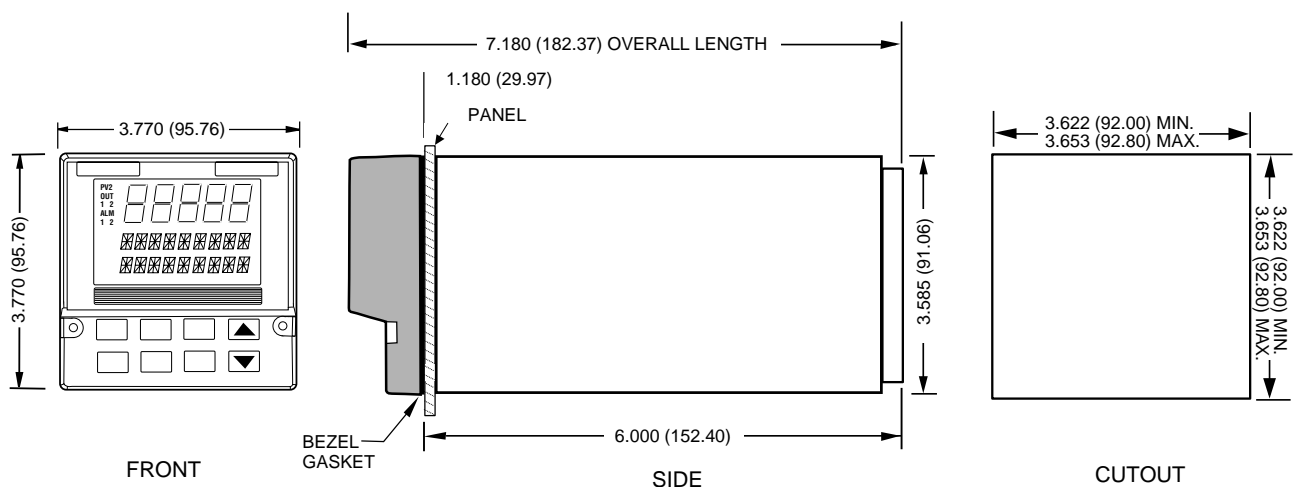

To obtain a waterproof seal between the station and the panel, make sure:

1. The panel cutout is precise.
2. You use a fresh gasket.
3. The edge of the cutout is free from burrs and “waves”.
4. The case of the station are centered in the cutout.

If you require a waterproof seal but have difficulty with these requirements, apply a bead of caulk or silicone sealant behind the panel around the perimeter of the case.

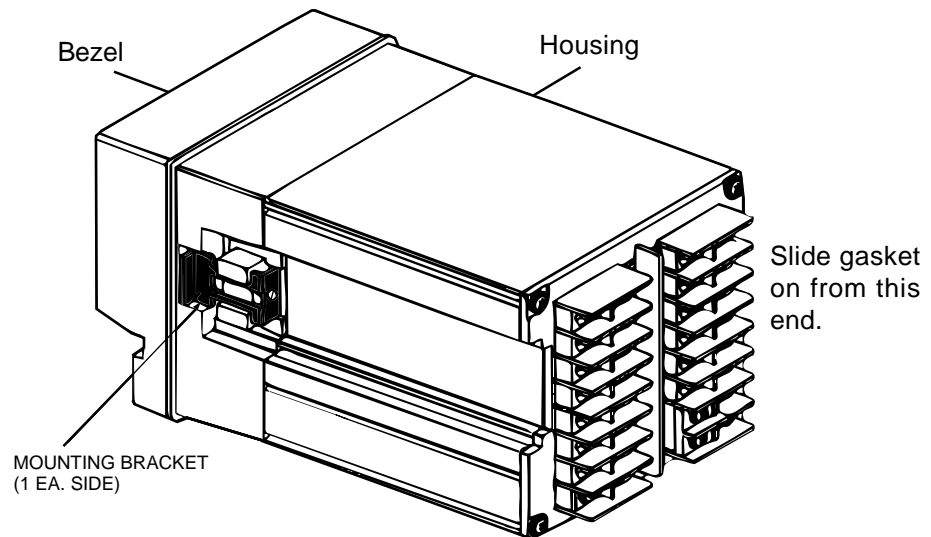

Figure 4.2
Mounting Brackets

C. Mount station into panel:

The instrument enclosure mounting **must be grounded** according to CSA Standard C22.2 No. 0.4.

You will need a long Phillips screw driver (#2).

1. Place bezel gasket around the station case (starting at the back of the station). Then, slide the gasket against the back of the bezel.
2. With the bezel gasket in place, insert the station into the panel cutout from the front of the panel.
3. From behind the panel, insert the mounting clips (one on each side), as shown in Figure 4.2.
4. Gradually tighten the mounting bracket screws.
5. Tighten the screws securely and check bezel gasket to ensure a tight, even seal.

WIRING THE 531 INPUTS

Figure 4.3 shows the rear terminal configurations for the 531. The actual instrument has only the top and bottom numbers of each column marked. Refer to this diagram for the following input and output wiring instructions.

IMPORTANT!!

When wiring the 531 terminals, **DO NOT use alligator clips** (they create an open circuit).

NOTE:

All wiring and fusing should conform to the National Electric Code and to any locally applicable codes.

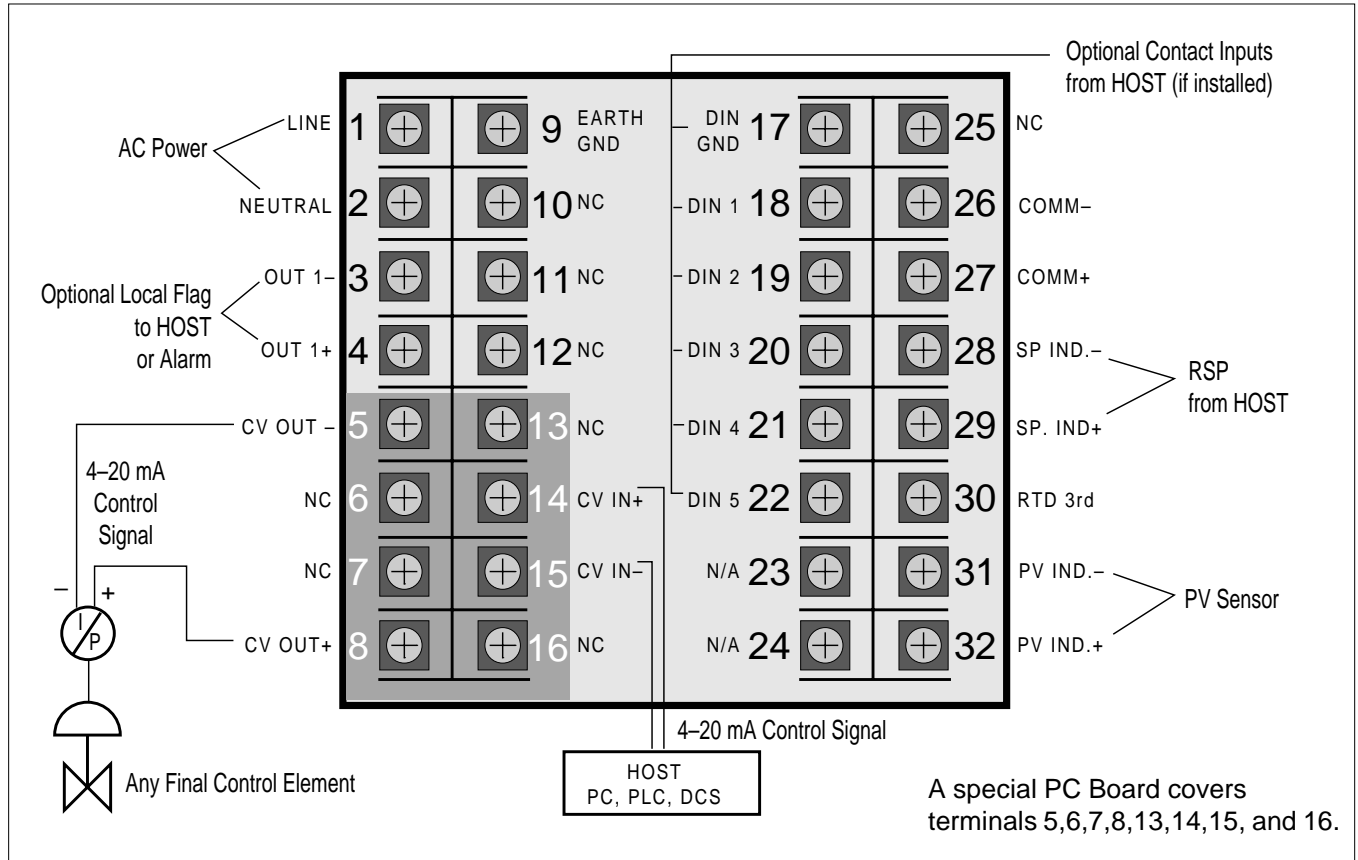
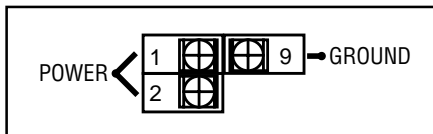

Figure 4.3
531 Rear Terminals

A. AC Power

Terminals 1 and 2 are for power. Terminal 9 is earth ground.



NOTE:

Use a 0.5 Amp, 250 V, fast-acting fuse in line with your AC power connection (terminal 1).

B. Process Variable

The station accommodates the following types of process variable inputs: Thermocouple, RTD, Voltage, Milliamp, Voltage and Millivolt.

1. Thermocouple Input

Use terminals 31 and 32 as shown.

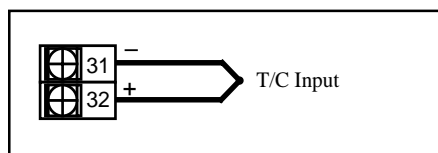

2. RTD Input

For 2, 3 or 4 wire RTD, use terminals 30, 31 and 32 as shown.

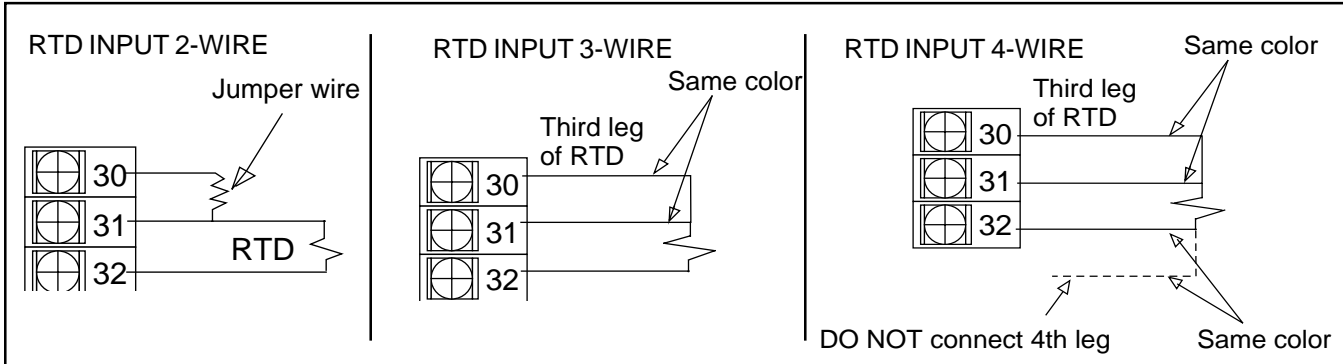

3. Voltage Input

Use terminals 31 and 32 as shown.

4. Milliamp Input -External Power Supply

Use terminals 31 and 32 with a 2-Wire transmitter.

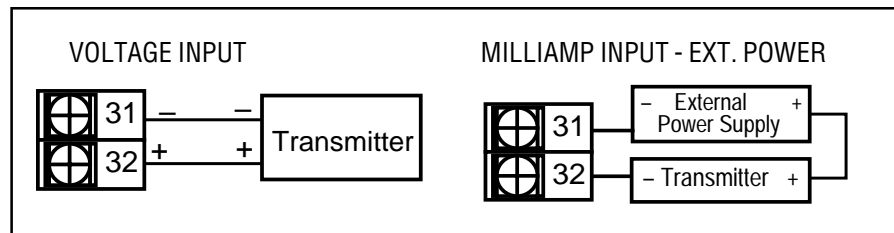

C. Digital Inputs

1. With a Switch

Use terminal 17 with the appropriate digital input terminal as shown.

2. With a Relay (dry contact)

Signal-type relay is recommended. Use terminal 17 with the appropriate digital input terminal as shown.

3. With an Open Collector (transistor)

11mA typical. 50Ω max. resistance. 50Ω max. loop resistance. Use terminals 17 with the appropriate digital input terminal as shown.

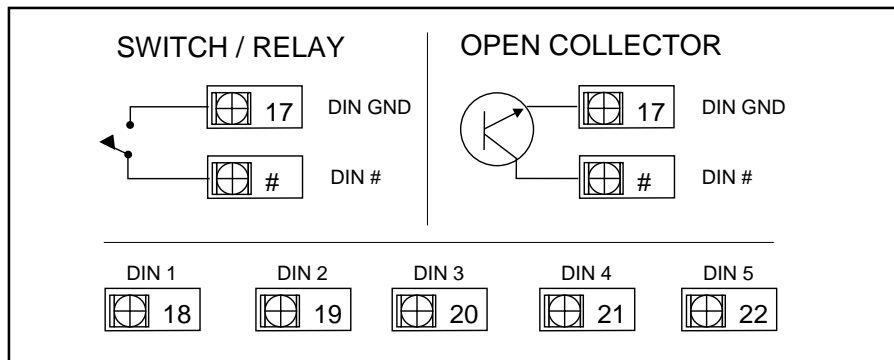

D. Remote Setpoint Indicator

Use terminals 28 and 29 as shown.

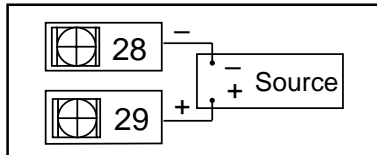

WIRING THE 531 OUTPUTS

- Output 1 is available for use as an ALARM or HOST FLAG with installation of a Mechanical Relay, Solid State Relay (Triac) module, or SSR Drive.
- The 531 is factory configured with an Analog module in Output 2.
- The 531 is factory configured with Mechanical Relays in Outputs 3 and 4.
- The 531 cannot be wired for retransmission.
- A small PC board fits over rear terminals 5 to 8 and 13 to 16.

These instructions explain proper wiring of the 531 for any output module. If you do not know which module(s) have been installed in your station, compare the number on the product label with the Order Code on page 3. To add or change position of jumper 1 or output module 1, refer to Chapter 3.

A. CV Output

- Use terminals 5 and 8 for CV Output as shown in Figure 4.4.
- Use terminals 14 and 15 for CV Input.

B. Mechanical Relay Output

- Use terminals 3 and 4 as shown in Figure 4.4.
- Jumper J1 can be set to normally open (NO) or normally closed (NC) as desired.

C. Solid State Relay (Triac) Output

- Use terminals 3 and 4 as shown in Figure 4.4.
- Jumper J1 must be set to normally open (NO).

D. DC Logic (SSR Drive) Output

- Use terminals 3 and 4 as shown in Figure 4.4.
- Jumper J1 must be set to normally open (NO).

WARNING!

DO NOT make any modifications to the factory setting of output modules 2, 3 and 4; this will place the product in an invalid and undefined state.

Figure 4.4
Output Wiring for the 531

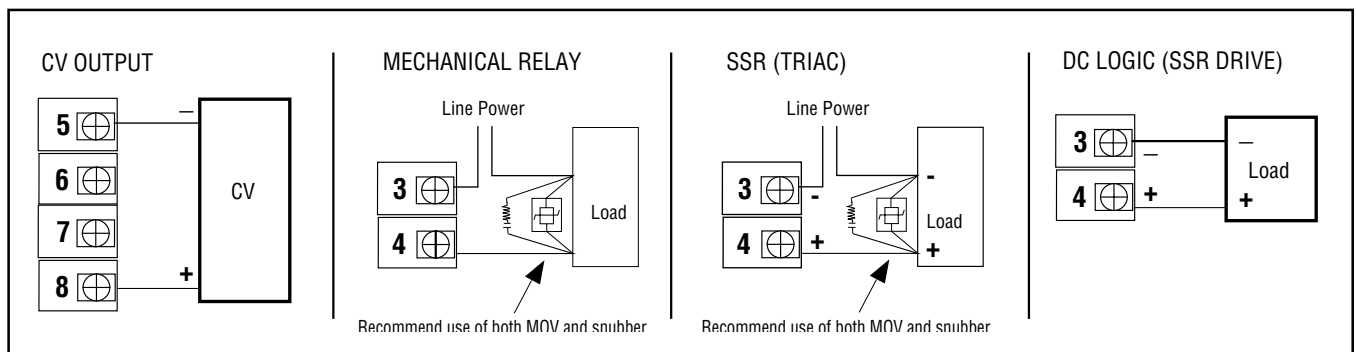

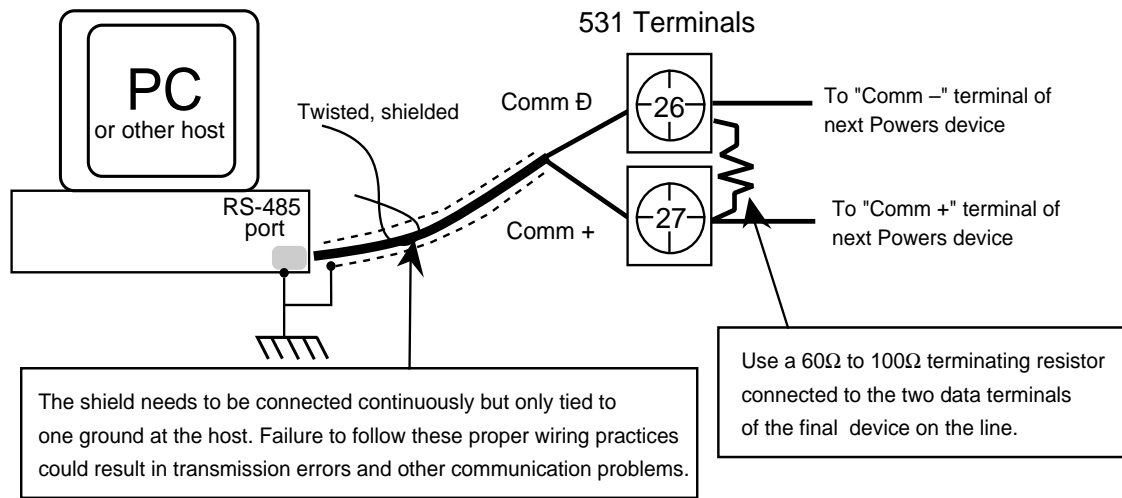

WIRING FOR SERIAL COMMUNICATIONS

Figure 4.5
Serial Communications Terminals

You must have this option installed on your 531 in order to use serial communications. Refer to Figure 4.5.

- Use a twisted shielded pair of wires to connect the host and field units. Belden #9414 foil shield has superior noise rejection characteristics. #8441 braid shield 22-gauge wire has more flexibility.
- The maximum recommended length of the RS 485 line is 4000 ft.
- Termination resistors are required at the host and the last device on the line. Some RS 485 cards/converters already have a terminating resistor. We recommend using RS-232/RS-485 converter (prod. no. 500-485).

WHERE TO GO NEXT

For a step-by-step guide on setting up the software features for your controller, see Chapter 5.

CHAPTER 5

SOFTWARE CONFIGURATION

MODE OVERVIEW

Upon power up, as well as during “normal” operation, the 531 is in one of its operating modes - **Host**, **Automatic** or **Manual**.

The 531 also has a set up (configuration) mode that lets you access options for adjusting the operation and display of the station. “Set up” is divided into two groups; one for the first eight menus (as listed below), and another for the **OPERATIONS** menu by itself.

Figure 5.1 illustrates the relationships among the three operating modes and nine set up menus.

The 8 set up menus can be accessed only when the 531 is in Host or Manual Mode. The **OPERATIONS** set up menu can be accessed when the 531 is in **Automatic, Host or Manual Mode**.

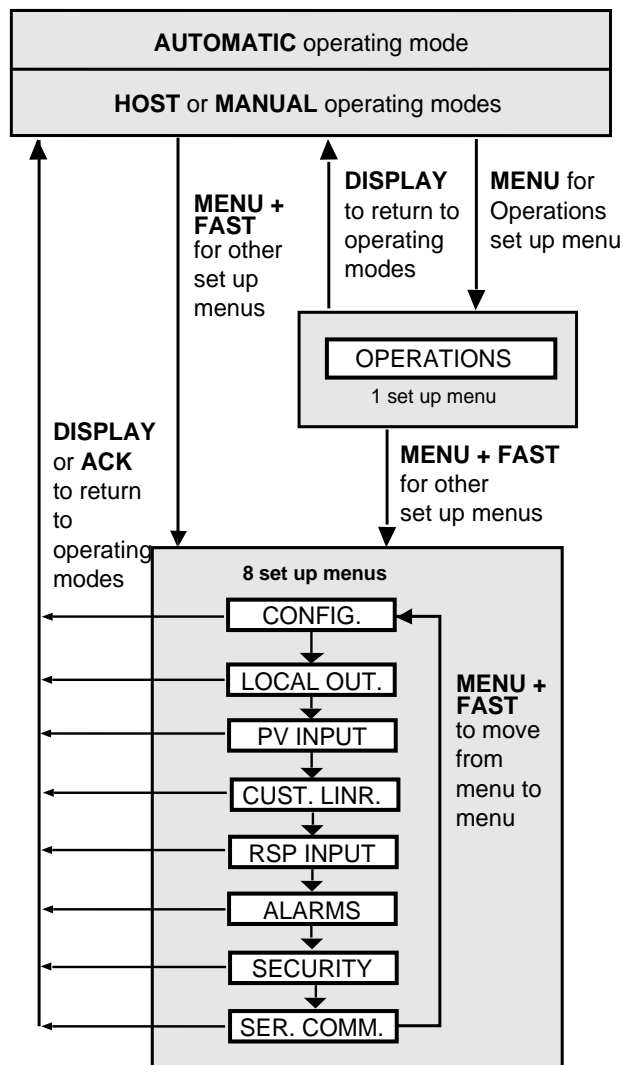

Figure 5.1
Menu Flowchart for Set Up

MENUS

A **menu** is a group of configuration control parameters. While in these set up menus, the name of the menu will appear in the 2nd display. The names of the different parameters within that menu group will then replace the menu name in the 2nd display. The values/options for each parameter will then appear in the 3rd display. Figure 5.1 displays the parts of the menu as used by this manual.

The (possible) menus for the 531 are:

- OPERATIONS To set up special PID control parameters and make adjustments to the transition functions (among operating modes) of the station.
- CONFIG. To configure the input and output hardware assignments.
- LOCAL OUT. To configure the local output control.
- PV INPUT To configure the process variable.
- CUST. LINR To configure the custom linearization curve for the process variable.
- RSP INPUT To configure the remote set point.
- ALARMS To configure alarms.
- SECURITY To configure the security function.
- SER. COMM. To configure serial communications.

SMART MENUS

This chapter outlines, in sequence, **all** menus, parameters, and selections available for the 531. However, the “smart menu” feature of the station allows only those Menu and Parameters to appear that are relevant to your hardware and software configuration, i.e., **parameters which do not apply to your application will not appear on your station’s display.**

- Parameters that apply to all configurations appear in this manual as a white on white box (Figure 5.2, left). These parameters are **independent** of your configuration.
- Parameters that **depend** on the configuration of the individual station appear as a black on white box (Figure 5.2, right).

Changing one parameter’s selection (or value) may affect another parameter. Refer to the section on the PV INPUT menu for an example on how this can affect your low and high range values.

Independent
Parameter

CONFIGURE
UNLOCKED

Dependent
Parameter

RSP TYPE
(D)

Figure 5.2
Independent vs. Dependent
Parameters

SOFTWARE CONFIGURATION PROCEDURES

On the bottom of each page is a guide to the keypad, to use during your configuration.

To access the 8 set up menus

1. Hold down the **FAST** key and press **MENU**. (see Figure 5.3). The **MENU** key will illuminate. The first Menu, **CONFIG.**, appears alone in the 2nd display.
2. Press **FAST + MENU** to advance to the next menu. The menu name will appear in the 2nd display.

To access the OPERATIONS set up menu

1. Press **MENU**. The **MENU** key will illuminate. OPERATION will appear in the 2nd display.

To advance through parameters and select a parameter value

1. When you reach your chosen menu, press **MENU**. The first parameter of this menu appears in the 2nd display, replacing the menu name. The first values/selection for the particular parameter appears in the 3rd display.
2. Press **▲** or **▼**, with or without the FAST key.
3. Press **MENU** to advance to next parameter.

To return to operating mode from configuration

1. Press the **DISPLAY** key. The station will return to the operating mode.

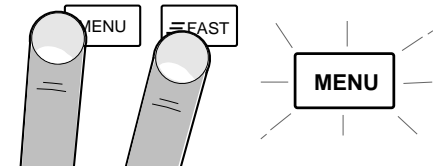

Figure 5.3
Keys to Enter and Move through Set Up Mode

WARNING!!

Scrolling through the choices to make selections will affect the operation of the instrument since changes to parameter selections occur in "real time" or immediately.

DO NOT MAKE ANY CHANGES DURING ON LINE OPERATION!

Escape to operating mode



Next parameter



Next menu



+



Next value



or



GUIDE TO SET UP PARAMETERS

Only parameters and selections relevant to your hardware and other software selections will appear on your station.

- Parameter Value
- (R) Parameter Range
- (D) Default Setting

CONFIG.

CONFIG

For configuring the input and output hardware assignments.

1. LOST HOST

Selects the type of local backup if 531 loses the host CV signal.

- MAN. OUT1 Switch to **Manual Mode**, use preset output MAN. OUT1
- MAN. OUT2 Switch to **Manual Mode**, use preset output MAN. OUT2
- MAN. LAST Go to **Manual Mode** using the last known output
- (D) AUTO.LOCAL Go to **Automatic (PID)Mode**
- AUTO.TRACK Go to **Automatic (PID)Mode** using last PV as the local SP

LOST HOST
AUTO.LOCAL

2. HOST.RESTR.

Selects the 531 mode upon host CV restoration.

- LOCAL Remain in **Manual (or Automatic) Mode**
- (D) HOST MODE Go to **Host Mode**

HOST.RESTR.
HOST

3. CONTACT 1

Defines the operation of the 1st digital input.

- MAN. LAST Switch to Local **Manual Mode**, use last output
- MAN. OUT1 Switch to **Manual Mode**, use preset output MAN. OUT1
- MAN. OUT2 Switch to **Manual Mode**, use preset output MAN. OUT2
- ALARM ACK. Acknowledge alarms
- UP KEY Remote **▲** key
- DOWN KEY Remote **▼** key
- COMM.ONLY Make status readable through communications
- DISP. KEY Remote **DISPLAY** key
- MENU KEY Remote **MENU** key
- FAST KEY Remote **FAST** key
- RST.INHBT. Inhibits PID reset action
- REMOTE SP Selects the Remote SP for **Automatic Mode**
- LOCAL SP Selects the Local SP for **Automatic Mode**
- (D) AUTO.LOCAL Go to **Automatic Mode**
- HOST MODE Go to **Host Mode**
- WATCHDOG Monitors the Host device for failure.

CONTACT1
AUTO.LOCAL

NOTE:

Refer to Chapter 6 for more on the Watchdog Monitor.

Escape to operating mode

DISPLAY

Next parameter

MENU

Next menu

FAST +

MENU

Next value

▼

or

▲

CONFIG

CONTACT 2

MAN.LAST

CONTACT 3

LOCAL SP

4. CONTACT 2

Defines the operation of the 2nd digital input.

- (D) MAN. LAST Switch to Local **Manual Mode**, use last output
- MAN. OUT1 Switch to **Manual Mode**, use preset output MAN. OUT1
- MAN. OUT2 Switch to **Manual Mode**, use preset output MAN. OUT2
- ALARM ACK. Acknowledge alarms
- UP KEY Remote **▲** key
- DOWN KEY Remote **▼** key
- COMM.ONLY Make status readable through communications
- DISP. KEY Remote **DISPLAY** key
- MENU KEY Remote **MENU** key
- FAST KEY Remote **FAST** key
- RST.INHBT. Inhibits PID reset action
- REMOTE SP Selects the Remote SP for **Automatic Mode**
- LOCAL SP Selects the Local SP for **Automatic Mode**
- AUTO.LOCAL Go to **Automatic Mode**
- HOST MODE Go to **Host Mode**
- WATCHDOG Monitors the Host device for failure

5. CONTACT 3

Defines the operation of the 3rd digital input.

- MAN. LAST Switch to Local **Manual Mode**, use last output
- MAN. OUT1 Switch to **Manual Mode**, use preset output MAN. OUT1
- MAN. OUT2 Switch to **Manual Mode**, use preset output MAN. OUT2
- ALARM ACK. Acknowledge alarms
- UP KEY Remote **▲** key
- DOWN KEY Remote **▼** key
- COMM.ONLY Make status readable through communications
- DISP. KEY Remote **DISPLAY** key
- MENU KEY Remote **MENU** key
- FAST KEY Remote **FAST** key
- RST.INHBT. Inhibits PID reset action
- REMOTE SP Selects the Remote SP for **Automatic Mode**
- (D) LOCAL SP Selects the Local SP for **Automatic Mode**
- AUTO.LOCAL Go to **Automatic Mode**
- HOST MODE Go to **Host Mode**
- WATCHDOG Monitors the Host device for failure.

CONFIG

6. CONTACT 4

Defines the operation of the 4th digital input.

- MAN. LAST Switch to Local **Manual Mode**, use last output
- MAN. OUT1 Switch to **Manual Mode**, use preset output MAN. OUT1
- MAN. OUT2 Switch to **Manual Mode**, use preset output MAN. OUT2
- (D) ALARM ACK. Acknowledge alarms
- UP KEY Remote ▲ key
- DOWN KEY Remote ▼ key
- COMM.ONLY Make status readable through communications
- DISP. KEY Remote **DISPLAY** key
- MENU KEY Remote **MENU** key
- FAST KEY Remote **FAST** key
- RST.INHBT. Inhibits PID reset action
- REMOTE SP Selects the Remote SP for **Automatic Mode**
- LOCAL SP Selects the Local SP for **Automatic Mode**
- AUTO.LOCAL Go to **Automatic Mode**
- HOST MODE Go to **Host Mode**
- WATCHDOG Monitors the Host device for failure.

CONTACT 4

ALARM ACK

7. CONTACT 5

Defines the operation of the 5th digital input.

- MAN. LAST Switch to Local **Manual Mode**, use last output
- MAN. OUT1 Switch to **Manual Mode**, use preset output MAN. OUT1
- MAN. OUT2 Switch to **Manual Mode**, use preset output MAN. OUT2
- ALARM ACK. Acknowledge alarms
- UP KEY Remote ▲ key
- DOWN KEY Remote ▼ key
- COMM.ONLY Make status readable through communications
- DISP. KEY Remote **DISPLAY** key
- MENU KEY Remote **MENU** key
- FAST KEY Remote **FAST** key
- RST.INHBT. Inhibits PID reset action
- REMOTE SP Selects the Remote SP for **Automatic Mode**
- LOCAL SP Selects the Local SP for **Automatic Mode**
- AUTO.LOCAL Go to **Automatic Mode**
- (D) HOST MODE Go to **Host Mode**
- WATCHDOG Monitors the Host device for failure.

CONTACT 5

HOST MODE

8. WATCHDOG

Defines function of the watchdog contact(s) for monitoring the Host.

- (D) DISABLED
- ENABLED

WATCHDOG

DISABLED

Escape to operating mode DISPLAY Next parameter MENU Next menu ≡FAST + MENU Next value ▼ or ▲

Software

CONFIG.

LINE FREQ.

60 Hz

OUTPUT 1

OFF

PID ACTION

REVERSE

STN. NAME

BYPASSER

LOCAL OUT.

AUTO.LO.LIM.

0%

AUTO.HI.LIM.

100%

MAN. OUT1

0.0%

MAN. OUT2

100.0%

9. LINE FREQ.

Specifies the power source frequency.

(D) 60 Hz

- 50 Hz

10. OUTPUT 1

Defines the function of the 1st output.

(D) OFF Deactivates output

- ALARM (Digital only)
- COMM.ONLY Output addressable only through communications

11. PID.ACTION

Select the PID control action.

- DIRECT

(D) REVERSE

12. STN. NAME

Allows you to enter a nine character message to name the station. To use: The first character of the 3rd display will be flashing. Use the ▲ and ▼ keys to scroll through characters. Press **FAST** to enter the selection and move to next digit. Press **MENU** to advance to next parameter.

(D) BYPASSER

LOCAL OUT.

To configure the local output control.

1. AUTO.LO.LIM.

Selects how low the Automatic PID output can be adjusted.

(R) 0% to 100%

(D) 0%

2. AUTO.HI.LIM.

Selects how high the Automatic PID output can be adjusted.

(R) 0% to 100%

(D) 100%

3. MAN. OUT1

Selects the **Manual Mode** preset output #1.

(R) -5.0% to 105.0%

(D) 0.0%

4. MAN. OUT2

Selects the **Manual Mode** preset output #2.

(R) -5.0% to 105.0%

(D) 100.0%

Escape to operating mode 

Next parameter 

Next menu  + 

Next value  or 

LOCAL OUT.

5. PWR.UP:MODE

Selects the power-up mode for the 531.

- MANUAL Manual Mode
- HOST MODE Host Mode
- (D) LAST MODE
- AUTO.LOCAL Automatic Mode (must have a valid PV signal)

PWR.UP:MODE

LAST MODE

6. MAN. PWR.UP

Determines the output percentage when the 531 powers up in **Manual Mode**.

- (R) -0.5% to 105%
- (D) LAST OUT

MAN. PWR.UP

LAST OUT

PV INPUT

For configuring the process variable (PV) input. The whole menu appears only if PV indicator is enabled.

PV INPUT

1. PV TYPE

Selects the particular sensor or input range.

FOR T/C INPUT:	FOR RTD INPUT:	FOR VOLTAGE INPUT:	FOR CURRENT (mA) INPUT:
(D) J T/C	(D) DIN RTD	(D) 1-5 V	(D) 4-20 mA
• E T/C	• JIS RTD	• 0-5 V	• 0-20 mA
• K T/C	• SAMA RTD	• 0-10 mV	
• B T/C		• 0-30 mV	
• N T/C		• 0-60 mV	
• R T/C		• 0-100 mV	
• S T/C		• +/-25 mV	
• T T/C			
• W T/C			
• W5 T/C			
• PLAT.II T/C			

PV TYPE

(D)

2. DEG. F/C/K

Selects the temperature unit if using a thermocouple or RTD.

- (D) FAHR.
- CELSIUS
- KELVIN

DEG. F/C/K

FAHR.

3. DECIMAL

Specifies the decimal point position.

FOR V/mA INPUT:	FOR RTD INPUT:
(D) XXXXX	(D) XXXXX
• XXXX.X	• XXXX.X
• XXX.XX	
• XX.XXX	
• X.XXXX	

DECIMAL

XXXXX

Escape to operating mode Next parameter Next menu + Next value or

Software

PV INPUT

LINEARIZE

NONE

LOW RANGE

(D)

HI RANGE

(D)

FILTER

0

PV OFFSET

0

PV GAIN

1.000

PV BREAK

0%

PV.RESTORE

AUTO.LOCAL

4. LINEARIZE

Specifies how to linearize the input. For V/mA Inputs only (Thermocouple and RTD inputs are automatically linearized).

- (D) NONE Normal linearization (2 point)
- SQR. ROOT Square root linearization
 - CUSTOM 15-point custom linearization curve

5. LOW RANGE

Specifies the engineering unit value corresponding to the lowest input value, e.g. 4 mA. For V/mA input only.

- (R) -9999 to 99999 (Maximum is HI RANGE)
- (D) Dependent upon the input selection

6. HI RANGE

Specifies the engineering unit value corresponding to the highest input value, e.g. 20 mA. For V/mA input only.

- (R) -9999 to 99999 (Minimum is LOW RANGE)
- (D) Dependent on the input selection

7. FILTER

Defines the setting in seconds for the low pass input filter.

- (R) 0 to 120
- (D) 0

8. PV OFFSET

Defines the offset to the process variable in engineering units.

- (R) -9999 to 99999
- (D) 0

9. PV GAIN

Defines the gain to the process variable. For V/mA input only.

- (R) 0.100 to 10.000
- (D) 1.000

10. PV BREAK

Determines the manual output value if the PV input is broken (station switches to Manual Mode).

- (R) -5% to 105%
- (D) 0%



11. PV.RESTORE

Determines manual output (source) upon PV restoration.

- MAN. LAST Maintain the last output from Manual Mode
- (D) AUTO.LOCAL Return to Automatic Control (and output)

Escape to operating mode 

Next parameter 

Next menu  + 

Next value  or 

CUST. LINR.

Defines a custom linearization curve for the process variable input. The curve may be either ever increasing or ever decreasing. However, plateaus or flat spots (adjacent points with the same PV) are allowable.

The curve has 15 points. Points 1 and 15 are fixed to the low and high end of the input range (respectively) and only require you to set a corresponding PV value. Points 2 through 14 (the X points) require you to set both the input and PV values.

NOTE: Changing the **PV TYPE** parameter in the **PV INPUT** menu clears the custom linearization curve and resets the linearization type to **NORMAL**. You must again select **CUSTOM** for the linearization type and reenter your curve, adjusted for the new input type.

1. 1ST. INPUT

Specifies the input signal for to the first point.

(D) The low end of the appropriate input range (e.g. 4.00 mA)

2. 1ST. PV

Specifies the engineering unit value for to the first point.

(R) -9999 to 99999

(D) 0

3. XTH. INPUT

Specifies the input signal for to the XTH point (X is 2 to 14) .

(R) Any value greater than the first input

(D) The low end of the appropriate input range (e.g. 4.00 mA)

4. XTH. PV

Specifies the engineering unit value for to the XTH point (X is 2 to 14).

(R) -9999 to 99999

(D) 0

You do not have to use all 15 points. Whenever the XTH INPUT becomes the high end of the input range, that will be the last point in the table.

5. 15TH. INPT.

Specifies the input signal for to the 15th point.

(R) -9999 to 99999

(D) The high end of the appropriate input range (e.g. 20.00 mA)

6. 15TH. PV

Specifies the engineering unit value for to the 15th point.

(R) -9999 to 99999

(D) 0

CUST. LINR.

1ST. INPUT

(D)

1ST. PV

0

XTH. INPUT

(D)

XTH. PV

0

15TH. INPT.

(D)

15TH. PV

0

Escape to operating mode

DISPLAY

Next parameter

MENU

Next menu

FAST +

MENU

Next value

▼

or

▲

RSP INPUT

RSP TYPE

(D)

RSP LOW

0

RSP HIGH

1000

SP OFFSET

0

RSP GAIN

1.000

TRACKING

YES

SP.RESTOR.

REMOTE SP

RSP INPUT

For configuring the remote setpoint (if enabled).

1. RSP TYPE

Specifies type of input signal that will be used for the setpoint indicator.

IF THE JUMPER IS IN THE mA POSITION

(D) 4-20 mA

- 0-20 mA

IF THE JUMPER IS IN THE V POSITION:

(D) 1-5 V

- 0-5 V

2. RSP LOW

Specifies the engineering unit value corresponding to the lowest setpoint indicator input value, e.g. 4 mA.

(R) -9999 to 99999

(D) 0

3. RSP HIGH

Specifies the engineering unit value corresponding to the highest setpoint indicator input value, e.g. 20 mA.

(R) -9999 to 99999

(D) 1000

4. RSP.OFFSET

Defines the offset to the remote setpoint in engineering units.

(R) -9999 to 99999

(D) 0

5. RSP GAIN

Defines the gain to the remote setpoint.

(R) 0.100 to 10.000

(D) 1.000

6. TRACKING

Determines whether or not the local SP will track the remote SP (upon RSP break, or switch to local from remote SP).

(D) YES

- NO

7. RSP.RESTOR.

Determines RSP (source) upon RSP input restoration.

- LOCAL SP

(D) REMOTE SP

ALARMS

For configuring alarms.

1. ALM. TYPE:1

This defines the type of alarm for alarm 1.

- (D) OFF Deactivates the first alarm
- LOCAL Causes an alarm when in local control (Host flag)
 - HIGH PV High alarm based on the process variable
 - LOW PV Low alarm based on the process variable
 - RATE Selects a rate-of-change alarm
 - BAND
 - DEVIATION
 - HIGH CV High alarm based on the control value
 - LOW CV Low alarm based on the control value

ALARMS

ALM. TYPE:1

OFF

2. ALARM SP:1

Specifies the alarm set point for alarm 1.

FOR ALM. TYPE:1 =

RATE	HIGH CV OR LOW CV	ANY OTHER TYPE
(R) -9999 to 99999 units	(R) 0.0–100.0%	(R) The PV range
(D) 0	(D) 0.0%	(D) Dependent on LOW RANGE

value

ALARM SP:1

(D)

3. DEADBAND:1

Defines the deadband for alarm 1.

FOR ALM. TYPE:1 =

HIGH CV OR LOW CV	ANY OTHER TYPE
(R) 0.1%–100.0%	(R) 1 to 9999
(D) 0.2%	(D) 2

DEADBAND:1

2

4. RELAY:1

Defines the state of the relay in the alarm condition for alarm 1.

- (D) RELAY ON
- RELAY OFF

RELAY:1

RELAY ON

5. LATCHING:1

Defines the latching sequence of alarm 1.

- (D) LATCH
- NO LATCH

LATCHING:1

LATCH

6. ACK.:1

Defines whether alarm 1 may be acknowledged.

- (D) ENABLED Allows the alarm to be acknowledged
- DISABLED Prevents existing alarm from being acknowledged

ACK.:1

ENABLED

Escape to operating mode

DISPLAY

Next parameter

MENU

Next menu

FAST +

MENU

Next value

▼

or

▲

Software

ALARMS

POWER UP:1

NORMAL

7. POWER UP:1

Defines how alarm 1 will be treated on power up.

- (D) NORMAL Alarm depends on process variable
- ALARM Power up in alarm regardless of PV
 - DELAYED Must leave alarm condition and reenter before activating the alarm

MESSAGE:1

ALARM 1

8. MESSAGE:1

Allows you to enter a nine character message associated with alarm 1. The first character of the 3rd display will be flashing. To enter message, press arrow keys to scroll through character set. Press **FAST** to enter the selection and move to next digit. Press **MENU** to advance to next parameter.

(D) ALARM 1

ALM. TYPE:2

OFF

9. ALM. TYPE:2

This defines the type of alarm for alarm 2.

- (D) OFF Deactivates the first alarm
- LOCAL Causes an alarm when in local control (Host flag)
 - HIGH PV High alarm based on the process variable
 - LOW PV Low alarm based on the process variable
 - RATE Selects a rate-of-change alarm
 - BAND
 - DEVIATION
 - HIGH CV High alarm based on the control value
 - LOW CV Low alarm based on the control value

ALARM SP:2

(D)

10. ALARM SP:1

Specifies the alarm set point for alarm 2.

FOR ALM. TYPE:2 =

RATE	HIGH CV OR LOW CV	ANY OTHER TYPE
(R) -9999 to 99999 units	(R) 0.0-100.0%	(R) The PV range
(D) 0	(D) 0.0%	(D) Dependent on LOW RANGE value

DEADBAND:2

2

11. DEADBAND:2

Defines the deadband for alarm 2.

FOR ALM. TYPE:2 =

HIGH CV OR LOW CV	ANY OTHER TYPE
(R) 0.1%-100.0%	(R) 1 to 9999
(D) 0.2%	(D) 2

RELAY:2

RELAY ON

12. RELAY:2

Defines the state of the relay in the alarm condition for alarm 2.

- (D) RELAY ON
- RELAY OFF

Escape to operating mode **DISPLAY**

Next parameter **MENU**

Next menu **FAST** + **MENU**

Next value **▼** or **▲**

13. LATCHING:2

Defines the latching sequence of alarm 2.

- (D) LATCH
- NO LATCH

14. ACK.:2

Defines whether alarm 2 may be acknowledged.

- (D) ENABLED Allows the alarm to be acknowledged
- DISABLED Prevents the alarm acknowledgment while alarm condition exists.

15. POWER UP:2

Defines how alarm 2 will be treated on power up.

- (D) NORMAL Alarm depends on process variable
- ALARM Always power up in alarm regardless of process variable
 - DELAYED Must leave alarm condition and reenter before activating the alarm

16. MESSAGE:2

Allows you to enter a nine character message associated with alarm 2. The first character of the 3rd display will be flashing. To enter message, press arrow keys to scroll through character set. Press **FAST** key to enter the selection and move to next digit. Press **MENU** key to advance to next parameter.

- (D) ALARM 2

17. RATE TIME

Defines the time period (in seconds) over which a rate-of-change alarm condition will be determined.

- (R) 1 to 3600
- (D) 5

SECURITY

For configuring the security function.

1. SEC. CODE

Defines security code for temporarily unlocking the station.

- (R) -9999 to 99999
- (D) 0

2. HOST KEY

Defines lockout status of the HOST key (mode changes via the HOST key).

- (D) UNLOCKED
- LOCKED

ALARMS

LATCHING:2

LATCH

ACK.:2

ENABLED

POWER UP:2

NORMAL

MESSAGE:2

ALARM 2

RATE TIME

5

SECURITY

SEC. CODE

0

HOST KEY

UNLOCKED

Escape to operating mode

DISPLAY

Next parameter

MENU

Next menu

FAST +

MENU

Next value

▼

or

▲

Software

SECURITY

MAN. KEY

UNLOCKED

MAN. OUT

UNLOCKED

LOCAL SP

UNLOCKED

ALARM ACK

UNLOCKED

OPERATION

UNLOCKED

CONFIGURE

UNLOCKED

SER. COMM.

STATION

1

3. MAN. KEY

Defines lockout status of the **MANUAL** key (mode changes via the **MANUAL** key).

(D) UNLOCKED

- LOCKED

4. MAN. OUT

Defines lockout status of the changes to the local output (via the ▲ and ▼ keys).

(D) UNLOCKED

- LOCKED

5. LOCAL SP

Defines lockout status of the changes to the local setpoint (via the ▲ and ▼ keys).

(D) UNLOCKED

- LOCKED

6. ALARM ACK.

Defines lockout status of the **ACK** key (alarm acknowledgment).

(D) UNLOCKED

- LOCKED

7. OPERATION

Defines lockout status of the **OPERATION** menu parameters.

(D) UNLOCKED

- LOCKED

8. CONFIGURE

Defines lockout status of the other 8 configuration parameters.

(D) UNLOCKED

- LOCKED

SER. COMM.

For configuring the serial communications features.

1. STATION

Defines the unit's station address.

(R) 1 to 99

- OFF

Disables the communications function.

(D) 1

Escape to operating mode 

Next parameter 

Next menu  + 

Next value  or 

SER. COMM.

2. BAUD RATE

Defines the baud rate.

- 1200 BPS
- 2400 BPS
- 4800 BPS
- (D) 9600 BPS
- 19200 BPS

BAUD RATE

9600

3. CRC

Defines whether CRC (cyclic redundancy check) is being calculated.

- (D) YES
- NO

CRC

YES

OPERATION

OPERATION

For modifications to the transition functions. **Use the same PID parameters as your HOST device.**

1. PROP. BAND

Defines the proportional band for the PID set.

- (R) 0.1% to 999.0%
- (D) 50.0%

PROP. BAND

50.0%

2. RESET

Defines the integral time for the PID set.

- (R) 1 to 9999 seconds/repeat
- (D) 30

RESET

20

3. RATE

Defines the derivative time for the PID set.

- (R) 0 to 600 seconds
- (D) 1

RATE

1

4. LOADLINE

Defines the loadline (manual reset) for the PID set.

- (R) 0% to 100%
- (D) 0%

LOADLINE

0%

5. SP SOURCE

Selects a local or remote setpoint.

- (D) LOCAL SP
- REMOTE SP (only for 2nd input V or mA)

SP SOURCE

LOCAL SP

Escape to operating mode

DISPLAY

Next parameter

MENU

Next menu

FAST

+

MENU

Next value

▼

or

▲

Software

OPERATION

MAN. RAMP

OFF

HOST RAMP

OFF

6. MAN. RAMP

Determines ramping value for output to a defined Manual output value (**MAN. OUT1**, **MAN. OUT2** or **PV BREAK**) upon transfer to **Manual Mode**.

(R) 0.1% to 999.9% per minute

(D) OFF

7. HOST RAMP



Determines ramping value for output to the **Host Mode** CV value, upon transfer to **Host Mode**.

(R) 0.1% to 999.9% per minute

(D) OFF

Escape to operating mode 

Next parameter 

Next menu  + 

Next value  or 

PARAMETER VALUE CHARTS

Record the values for the various configuration menu parameters on the charts in this section.

NOTE:

You may want to photocopy these pages instead of entering the values on the master sheets.

CONFIG.

For configuring the input and output hardware assignments.

1.	LOST HOST	Selects the type of local backup when host CV breaks.	
2.	HOST. RESTR.	Selects the 531 mode upon host CV restoration.	
3.	CONTACT 1	Defines the operation of the 1st digital input.	
4.	CONTACT 2	Defines the operation of the 2nd digital input.	
5.	CONTACT 3	Defines the operation of the 3rd digital input.	
6.	CONTACT 4	Defines the operation of the 4th digital input.	
7.	CONTACT 5	Defines the operation of the 5th digital input.	
8.	WATCHDOG	Defines function of Host watchdog monitor.	
9.	LINE FREQ.	Specifies the power source frequency.	
10.	OUTPUT 1	Defines the function of the 1st output.	
11.	PID.ACTION	Select the PID control action.	
12.	STN. NAME	Specifies a nine character message to name the station.	

LOCAL OUT.

To configure the local output control.

1.	AUTO.LO.LIM.	Selects low limit for adjusting the Automatic PID output.	
2.	AUTO.HI.LIM.	Selects high limit for adjusting the Automatic PID output.	
3.	MAN. OUT1	Selects the Manual Mode preset output #1.	
4.	MAN. OUT2	Selects the Manual Mode preset output #2.	
5.	PWR.UP:MODE	Selects the power-up mode for the 531.	
6.	MAN. PWR.UP	Determines output % for in Manual Mode power up.	

PV INPUT

For configuring the process variable (PV) input. The whole menu appears only if PV indicator is enabled.

1.	PV TYPE	Selects the particular sensor or input range.	
2.	DEG. F/C/K	Selects the temperature unit for a T/C or RTD.	
3.	DECIMAL	Specifies the decimal point position.	
4.	LINEARIZE	Specifies how to linearize the input.	
5.	LOW RANGE	Specifies the lowest input value (engineering units).	
6.	HI RANGE	Specifies the highest input value (engineering units).	
7.	FILTER	Defines setting in seconds for the low pass input filter.	
8.	PV OFFSET	Defines offset to the PV in engineering units.	
9.	PV GAIN	Defines gain to the PV.	
10.	PV BREAK	Determines the manual output if PV input breaks.	
11.	PV.RESTORE	Determines manual output (source) upon PV restoration.	

CUST. LINR.

Defines a custom linearization curve for the process variable input.

1.	1ST. INPUT	Specifies the input signal for the 1st point.	
2.	1ST. PV	Specifies the engineering unit value for the 1st point.	
3.	2ND. INPUT	Specifies the input signal for the 2nd point.	
4.	2ND. PV	Specifies the engineering unit value for the 2nd point.	
5.	3RD. INPUT	Specifies the input signal for the 3rd point.	
6.	3RD. PV	Specifies the engineering unit value for the 3rd point.	
7.	4TH. INPUT	Specifies the input signal for the 4th point.	
8.	4TH. PV	Specifies the engineering unit value for the 4th point.	
9.	5TH. INPUT	Specifies the input signal for the 5th point.	
10.	5TH. PV	Specifies the engineering unit value for the 5th point.	
11.	6TH. INPUT	Specifies the input signal for the 6th point.	
12.	6TH. PV	Specifies the engineering unit value for the 6th point.	
13.	7TH. INPUT	Specifies the input signal for the 7th point.	
14.	7TH. PV	Specifies the engineering unit value for the 7th point.	
15.	8TH. INPUT	Specifies the input signal for the 8th point.	
16.	8TH. PV	Specifies the engineering unit value for the 8th point.	
17.	9TH. INPUT	Specifies the input signal for the 9th point.	
18.	9TH. PV	Specifies the engineering unit value for the 9th point.	
19.	10TH. INPT.	Specifies the input signal for the 10th point.	
20.	10TH. PV	Specifies the engineering unit value for the 10th point.	
21.	11TH. INPT.	Specifies the input signal for the 11th point.	
22.	11TH. PV	Specifies the engineering unit value for the 11th point.	
23.	12TH. INPT.	Specifies the input signal for the 12th point.	
24.	12TH. PV	Specifies the engineering unit value for the 12th point.	
25.	13TH. INPT.	Specifies the input signal for the 13th point.	
26.	13TH. PV	Specifies the engineering unit value for the 13th point.	
27.	14TH. INPT.	Specifies the input signal for the 14th point.	
28.	14TH. PV	Specifies the engineering unit value for the 14th point.	
29.	15TH. INPT.	Specifies the input signal for the 15th point.	
30.	15TH. PV	Specifies the engineering unit value for the 15th point.	

RSP INPUT

For configuring the remote setpoint (if enabled).

1.	RSP TYPE	Specifies type of input signal for the remote SP.	
2.	RSP LOW	Lowest (engineering unit) value for the remote SP.	
3.	RSP HIGH	Highest (engineering unit) value for the remote SP.	
4.	RSP.OFFSET	Defines the offset to the remote SP in engineering units.	
5.	RSP GAIN	Defines the gain to the remote setpoint.	
6.	TRACKING	Determines whether or not local SP tracks remote SP.	
7.	RSP.RESTOR.	Determines SP (source) upon RSP input restoration.	

ALARMS

For configuring alarms.

1.	ALM. TYPE:1	Defines the type of alarm for alarm 1.	
2.	ALARM SP:1	Specifies the alarm set point for alarm 1.	
3.	DEADBAND:1	Defines the deadband for alarm 1.	
4.	RELAY:1	Defines the state of the relay for alarm 1.	
5.	LATCHING:1	Defines the latching sequence of alarm 1.	
6.	ACK.:1	Defines whether alarm 1 may be acknowledged.	
7.	POWER UP:1	Defines how alarm 1 will be treated on power up.	
8.	MESSAGE:1	A nine character message for alarm 1.	
9.	ALM. TYPE:2	Defines the type of alarm for alarm 2.	
10.	ALARM SP:2	Specifies the alarm set point for alarm 2.	
11.	DEADBAND:2	Defines the deadband for alarm 2.	
12.	RELAY:2	Defines the state of the relay for alarm 2.	
13.	LATCHING:2	Defines the latching sequence of alarm 2.	
14.	ACK.:2	Defines whether alarm 2 may be acknowledged.	
15.	POWER UP:2	Defines how alarm 2 will be treated on power up.	
16.	MESSAGE:2	A nine character message for alarm 2.	
17.	RATE TIME	Defines the time period for a rate-of-change alarm.	

SECURITY

For configuring the security function.

1.	SEC. CODE	Security code for temporarily unlocking the station.	
2.	HOST KEY	Lockout status of the HOST key.	
3.	MAN. KEY	Lockout status of the MANUAL key.	
4.	MAN.OUT	Lockout status of the changes to the local output.	
5.	LOCAL SP	Lockout status of the changes to the local setpoint.	
6.	ALARM ACK.	Lockout status of the ACK key.	
7.	OPERATION	Lockout status of the OPERATION Menu parameters.	
8.	CONFIGURE	Lockout status of the other 8 configuration parameters.	

SER. COMM.

For configuring the serial communications features.

1.	STATION	Defines the unit's station address.	
2.	BAUD RATE	Defines the baud rate.	
3.	CRC	Defines whether CRC is being calculated.	

OPERATION

For modifications to the transition functions. **Use the same PID parameters as your HOST device.**

1.	PROP. BAND	Defines the proportional band for the PID set.	
2.	RESET	Defines the integral time for the PID set.	
3.	RATE	Defines the derivative time for the PID set.	
4.	LOADLINE	Defines the loadline (manual reset) for the PID set.	
5.	SP SOURCE	Selects a local or remote setpoint.	
6.	MAN.RAMP	Determines ramping for output to Manual output value.	
7.	HOST RAMP	Determines ramping for output to the Host Mode CV.	

CHAPTER 6

531 APPLICATIONS

The 531 has a variety of user-programmable control features and capabilities. This chapter describes how to apply them.

SECTION	PAGE
531 Operation	45
Alarms	46
Digital Inputs	50
Watchdog Monitor	51
Process Variable and Setpoint	51
Input Linearization	53
Ramp to a Control Value	54
Security	55
Process Variable Reading Correction	56
Serial Communications	56

NOTE:

Available capabilities depend upon the hardware option you specified and ordered.

531 OPERATION

The 531 PID Backup Station provides PID based control backup for critical control loops. It is normally installed between a Host device and final control element. The Host device may be a PLC, DCS or single loop controller (SLC). The final control element may be a valve actuator, positioning device, power control unit for an electric heating element, pump or other control device. The control signal must always be a 4-20mA proportional signal.

NOTE:

In this chapter, the following abbreviations are used:

- CV** - Control signal
- SP** - Set point
- PV** - Process variable

Host Mode (Default Mode)

- The HOST key is lit.
- In Host Mode, the 531 is transparent to the control loop; it passes the control signal from the Host device without any degradation.
- The 531 constantly monitors the CV and uses the last good signal as a potential CV for the **Automatic Mode**.
- The 531 can be removed from the case without disrupting the Host signal; it is not a point of failure.
- The 531 switches to **Host Mode** due to:
 - Return of the Host signal
 - Keypad selection
 - Closure of a digital contact; or
 - Commands through the RS-485 port.
- Upon return of the **Host signal**, the 531 can be programmed to
 - Return control to the Host Mode immediately;
 - Ramp to the new CV at a predetermined rate; or
 - Remain in the current mode, where the operator can determine whether or not the Host signal is valid.
- The operator can modify the local SP using the ▲ and ▼ keys.
- The operator can enter all the configuration menus.

Escape to operating mode	[DISPLAY]	Next parameter	[MENU]	Next menu	[≡FAST] + [MENU]	Next value	[▼]	or	[▲]
--------------------------	-----------	----------------	--------	-----------	------------------	------------	-----	----	-----

Automatic Mode

- Neither the **HOST** nor **MANUAL** keys are lit.
- The 531 switches to **Automatic (PID) Mode** due to:
 - Loss of the Host signal
 - Keypad selection
 - Closure of a digital contact; or
 - Commands through the RS-485 port.
- Upon switching to **Automatic Mode**, the 531 generates a control signal based on PID control.
- The 531 executes a bumpless transfer to the new CV while in PID mode (no ramping needed).
- The operator can modify the local SP using the ▲ and ▼ keys.
- The operator can only enter the **OPERATION** menu (other configuration menus are disabled).

Manual Mode

- The **MANUAL** key is lit.
- The 531 switches to **Manual Mode** due to:
 - Loss of the Host signal and PV input
 - Keypad selection
 - Closure of a digital contact; or
 - Commands through the RS-485 port.
- In **Manual Mode**, the 531 can go to a predetermined output. The 531 can also be set to ramp the last Host signal to the new output.
- The operator can modify the CV signal using the ▲ and ▼ keys.
- The operator can modify the local SP using the ▲ and ▼ keys.
- The operator can enter all the configuration menus.

NOTE:

Refer to Chapter 4 for information on wiring for alarms.

NOTE:

Refer to “Alarm Operation” in Chapter 2 for information on operating alarms.

ALARMS

The 531 has 2 alarms available. It indicates alarm conditions by:

- Lighting up the alarm icon(s).
- Displaying a custom message in the 3rd display
- Illuminating the **ACK** key if the alarm is acknowledgeable.

Each alarm can be assigned one of 6 different types. Also, by adding an output module, one of the alarms can be tied to a relay output. To assign an alarm:

1. Press **FAST + MENU** to toggle to the **ALARM** menu.
2. Press **MENU** to select the first parameter ALM.TYPE:1 and select its type (choose one of the following) using the ▲ and ▼ keys:



LOCAL

(Host Flag) If tied to a relay output, a local alarm notifies the Host that the 531 has taken over the output in **Manual** or **Automatic** mode.

You can choose LOCAL for only one of the alarms. Useful when the Host performs logging functions for Statistical Process Control (SPC), or to prevent reset windup.

Escape to operating mode 

Next parameter 

Next menu  + 

Next value  or 

HIGH PV

Occurs when the process variable exceeds the alarm setpoint.

LOW PV

Occurs when the process variable goes below the alarm setpoint.

RATE

Use to signal an alarm when the PV changes at a rate greater than that specified by the alarm setpoint and time base. For example, if you have an alarm setpoint of 10 and a time base of 5 seconds, an alarm occurs if the PV changes greater than 10 units in 5 seconds.

BAND

Creates a band twice the size of the alarm setpoint [centered] around the control setpoint. Alarm occurs when the process variable travels outside of this band. For example, if your control setpoint is 500 and the alarm setpoint is 25, the alarm occurs if the PV travels outside of the 475 to 525 range.

Alarm is dependent upon retransmission of the control setpoint. As the control setpoint changes, the band centers itself accordingly.

DEVIATION

Creates a band on one side of the control setpoint. Alarm occurs when the process variable deviates from the control setpoint by an amount greater than the alarm setpoint.

For example, if the control setpoint is 500 and the alarm setpoint is +50 (plus 50), an alarm occurs when the process variable exceeds 550. If your alarm setpoint is -50, the alarm occurs when the process variable drops below 450.

Alarm is dependent upon retransmission of the control setpoint. As the control setpoint changes, the band centers itself accordingly.

HIGH CV

Occurs when the control value exceeds the alarm setpoint.

LOW CV

Occurs when the control value goes below the alarm setpoint.

3. Press the **MENU** key to select the second parameter ALM.TYPE:2 and select its type using the s and t keys.

Each **alarm type** (except a LOCAL alarm) has a number of corresponding parameters that must also be set up in the **ALARM** menu (steps 4 - 11).

Press the **MENU** key to select the rest of the parameters in the ALARM Menu, and choose their values with the ▲ and ▼ keys.

4. ALARM SP:1 and ALARM SP:2

Specifies, in engineering units, the point at which the alarm occurs.

For a rate-of-change alarm, it specifies the amount of change that must occur before the alarm activates. A negative value specifies a negative rate-of-change.

5. DEADBAND:1 and DEADBAND:2

Specifies the range through which the PV must travel before leaving an alarm condition (see alarm examples at the end of this section).

NOTE:

The Band and Deviation alarms are not selectable without a PV and a retransmitted SP signal.

NOTE:

The HIGH CV and LOW CV alarms, when selected, operate in both Host and Local modes.

NOTE:

Only those parameters that apply to your particular alarm type will appear as you toggle through the parameters.

Escape to operating mode

DISPLAY

Next parameter

MENU

Next menu

FAST +

MENU

Next value

▼

or

▲

Applications

NOTE:

You can specify whether the relay is Normally Open or Normally Closed when configuring the hardware, with jumper selection only for Output 1.

This prevents frequent alarm oscillation or “chattering” if the process variable has stabilized around the alarm point.

6. RELAY:1

Specifies whether the relay will be on or off. ON means the relay is energized, while OFF means the relay is de-energized when the station is in the alarm condition.

Most applications require the relay to energize. However, limit applications usually require the relay to de-energize.

7. LATCHING:1 and LATCHING:2

If the alarm is latching (YES), the alarm remains active after leaving the alarm condition unless acknowledged.

If the alarm is non-latching (NO) the alarm returns to its non-alarm state when leaving the alarm condition without being acknowledged.

8. ACK.:1 and ACK.:2

ENABLED allows the operator to acknowledge an alarm at any time, even if the control process is still in the alarm condition.

DISABLED prevents the operator from acknowledging an alarm while the process is in the alarm condition.

When either alarm is available to be acknowledged, the **ACK** key will be illuminated. If both alarms are acknowledgeable, press the **ACK** key once to acknowledge alarm #1, then a second time for alarm #2. A latching alarm can always be acknowledged when it is out of the alarm condition.

9. POWER UP:1 and POWER UP:2

If you want the controller to always power up in alarm, regardless of the alarm condition, then select ALARM. This is an excellent way to activate an alarm if there has been a power failure.

If you never want the controller to power up in alarm, regardless of alarm condition, select DELAYED. The system must leave and reenter the alarm condition before the alarm will activate. This is typically used to avoid alarms during start up.

If you want the system to power up in alarm only if it is in an alarm condition, select NORMAL.

10. MESSAGE:1 and MESSAGE:2

Allows you to enter a nine character message to display when the respective alarm is active. The first character of the 3rd display will be flashing. Use ▲ and ▼ keys to scroll through character set for each character. Press **FAST** to enter the selection and move to the next digit. Press **MENU** to advance to next parameter.

11. RATE TIME

Defines the time period over which a specific change in process variable must occur for the rate alarm to be activated. The amount of change is defined by the alarm setpoint. The rate-of-change is defined as the amount of change divided by the time period. In general, for a given rate-of-change, the shorter the time period, the more sensitive the rate alarm.

Escape to operating mode

Next parameter

Next menu +

Next value or

Examples:

1. If the alarm setpoint is set to 10 and the time base is set to 1 second, the rate of change is 10 units per second. The process variable would only have to experience a ten unit change over a short period of time.
2. If the alarm setpoint is set to 100 and the time base set to 10, the rate of change is also 10 units per second. The PV would require a 100 unit change over a ten second period.

Notice that Example 1 is more sensitive than Example 2.

Alarm Examples

A.SP = Alarm Setpoint C.SP = Control Setpoint DB = Deadband PV = Process Variable

Figure 6.1
Alarm Examples

A. BAND ALARM EXAMPLE

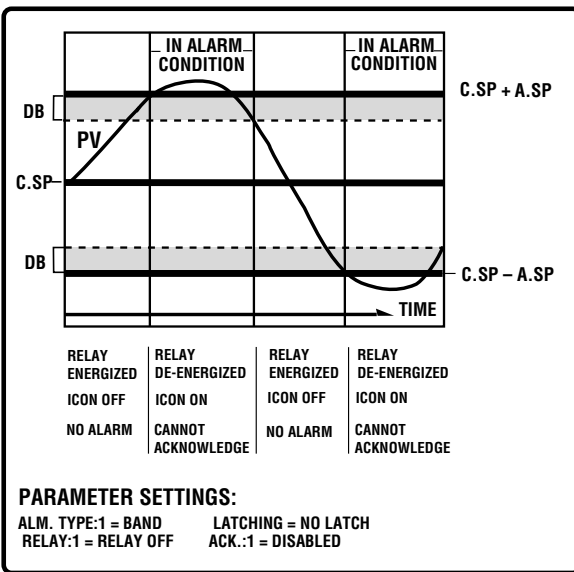

B. HIGH PROCESS VARIABLE ALARM EXAMPLE

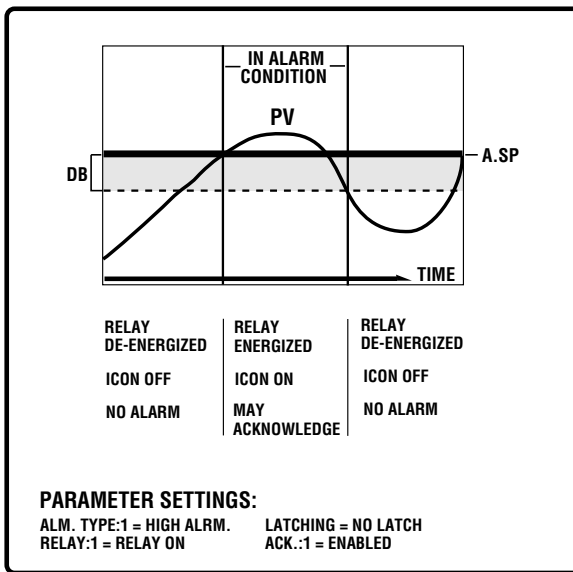

C. DEVIATION ALARM EXAMPLE

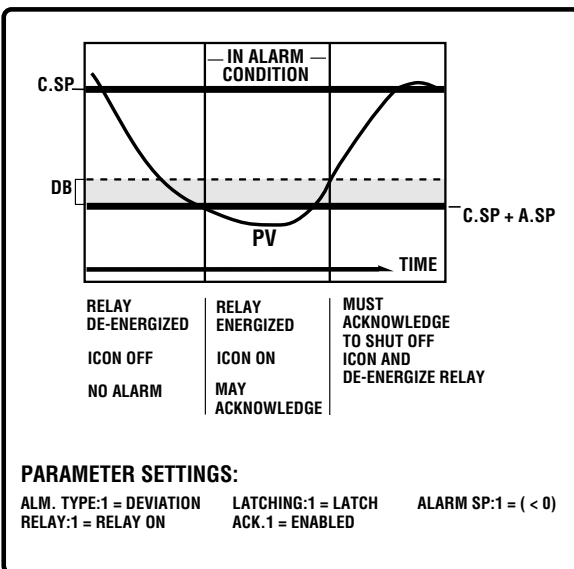

D. POWER UP ALARM EXAMPLE

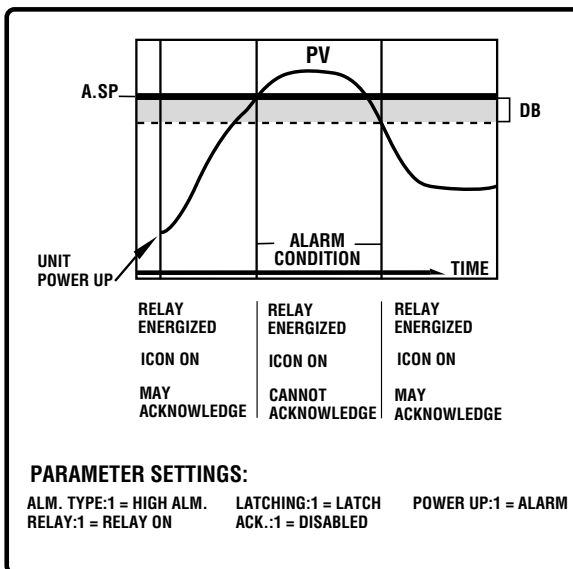

Escape to operating mode DISPLAY Next parameter MENU Next menu ≡FAST + MENU Next value ▼ or ▲

NOTE:

To verify your hardware configuration, check your product label on top of the 531, and compare it to the order code in Chapter 1.

DIGITAL INPUTS

This optional feature is only available if ordered originally from the factory. For a set of 5 digital inputs can be ordered, order Product #531 -xxxxxxDx00.

If more than one digital input is closed, then the last one closed generally has priority over the others.

A closed digital input may be overridden by: another digital input, a keyboard operation, or an automatic function. A closed digital input that was overridden must be opened, in order to be “re-armed”.

If one digital input is closed and selects LOCAL, and then REMOTE is keyboard selected, the keyboard selection takes precedence.

1. Press **FAST + MENU** to toggle to the **CONFIG.** menu
2. Press **MENU** to access first parameter, CONTACT:1. Use **▲** and **▼** to toggle to the desired function (choose one of the following):

MAN. LAST

Contact closure switches the station to **Manual Mode** using the last output value.

MAN. OUT1

Contact closure switches the station to **Manual Mode** using the MAN.OUT1 value.

MAN. OUT2

Contact closure switches the station to **Manual Mode** using the MAN.OUT2 value.

ALARMACK.

Contact closure acknowledges all active alarms. The digital input must be opened before it is “re-armed.” If the input remains closed, it will not continue to immediately acknowledge alarms as they become active.

UP KEY and DOWN KEY

Contact closure mimics the **▲** and **▼** keys. If the station is mounted behind a window, this digital input allows you to use momentary contact push button to change the station’s output.

COMM. ONLY

Contact closure renders digital input status readable through communications. It will have no effect on the functions of the station itself.

DISP. KEY

Contact closure mimics the **DISPLAY** key.

MENU KEY

Contact closure mimics the **FAST** key.

FAST KEY

Contact closure mimics the **FAST** key.

RST. INHBT.

Contact closure inhibits local PID reset action.

REMOTE SP

Contact closure selects the remote setpoint for use in Automatic Mode.

Escape to operating mode 

Next parameter 

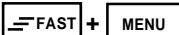
Next menu 

Next value  or 

LOCAL SP

Contact closure selects the local setpoint for use in **Automatic Mode**.

AUTO.LOCAL

Contact closure switches the station to **Automatic Mode**.

HOST MODE

Contact closure switches the station to **Host Mode**.

WATCHDOG

Contact closure activates the watchdog monitor.

2. Press **MENU** to access contact parameters, CONTACT:2, CONTACT:3, CONTACT:4, and CONTACT:5. Use the ▲ and ▼ keys to toggle to the desired function for these as well.

WATCHDOG MONITOR

This feature is only available with the factory installed five digital inputs.

The 531 normally uses the presence of the CV for determining Host failure. In some cases, however, a Host can “lock up” or “hang up,” leaving its mA control output frozen at a constant value.

To protect against this type of Host failure, one of the Host relay outputs may be programmed to provide a pulse, or “watchdog,” output. A 531 digital input can be set to monitor this pulse. If the pulse state does not change (toggle) in a 0.4 to 2.5 second period, then the 531 will record the Host’s CV signal as unreliable, and appropriately report a lost CV as Host failure.

To configure a digital input as a watchdog monitor:

1. Press **FAST + MENU** to toggle to the **CONFIG** menu.
2. Press **MENU** to access parameter CONTACT:1 (or 2, 3, 4 or 5). Use the ▲ or ▼ key to select the value WATCHDOG.
3. Press **MENU** to access parameter WATCHDOG. To activate the watchdog monitor, set this value to ENABLED.

PROCESS VARIABLE AND SETPOINT

The 531 can be set up to display the process variable and a retransmitted setpoint. The process variable can be a direct input of a thermocouple, RTD, mA or voltage signal. Milliamp and voltage signal can be displayed as 0–100% or scaled in Engineering units. Custom linearization is also available.

Select the Process Variable Display Range

1. Press the **FAST + MENU** keys to toggle to the **PV INPUT** menu. Press **MENU** to access the following parameters. Use the ▲ and ▼ keys to assign values.
2. PV TYPE
Defines the range of the input signal (T/C, RTD, mA or voltage signal). The type of signal is governed by the hardware jumper selections (see Chapter 3).

Escape to operating mode		Next parameter		Next menu	+	Next value		or	
--------------------------	--	----------------	--	-----------	---	------------	--	----	--

3. DEG. F/C/K
Selects the units for temperature display (appears only for T/C and RTD input types).
4. DECIMAL
Sets the position of the decimal point (appears only for V/mA and RTD input types).
5. LINEARIZE
Selects the type of PV linearization being used (appears only for V/mA input types).
6. LOW RANGE
Sets the value in engineering units corresponding to the low PV input value (appears only for v/mA input types).
7. HI RANGE
Sets the value in engineering units corresponding to the high PV input value (appears only for V/mA inputs types).
8. FILTER
Sets the amount of PV filtering to be used.
9. PV OFFSET
Sets a constant offset to be applied to the PV input.
10. PV GAIN
Sets a constant gain to be applied to the PV input (appears only for V/mA input types).
11. PV BREAK
Sets the manual output value if the PV input is broken while running local PID.
12. PV. RESTORE
Sets the mode upon restoration of the PV input.

Set Point Display Range

The 531 can be set up to display a retransmitted setpoint from the Host device.

1. Press **FAST + MENU** to toggle to the **RSP INPUT** Menu . Press **MENU** to access the following parameters, and use **▲** and **▼** to assign values.
2. RSP TYPE
Defines the input signal range: 0-20mA or 4-20mA (or 0-5V or 1-5V).
3. RSP LOW and RSP HIGH
Define the range of the set point in engineering units. The correct range will be dependent on the source of the set point signal.
4. RSP.OFFSET
Define the offset of the remote set point in engineering units.
5. RSP GAIN
Define the gain to the remote set point in engineering units.
6. TRACKING
Determines if the Local SP will track the Remote SP upon RSP break or transfer to the local SP value.

Escape to operating mode

Next parameter

Next menu

Next value or

7. RSP.RESTOR.

Define the setpoint (source) upon remote set point signal restoration from break.

INPUT LINEARIZATION

Thermocouple and RTD Linearization

When you select a thermocouple or RTD input, the station automatically linearizes the incoming signal. The station uses internal lookup tables to provide an accurate reading of the temperature being sensed.

Square Root Linearization

Many flow transmitters generate a nonlinear signal corresponding to the flow being measured. The station must have the square root of this signal in order to use it. The station has the capability to perform this function for itself.

To utilize this feature, you must have a voltage or milliamp input.

1. Press **FAST + MENU** to toggle to the **PV INPUT** Menu .
2. Press **MENU** to access the **LINEARIZE** parameters, and use the **▲** and **▼** to assign value **SQR. ROOT**.

For the first 1% of the input span, the input is treated in a linear fashion. After that, the input is a value calculated using the formula shown in Figure 6.2.

$$PV = \text{Low Range} + \left[(\text{Hi Range} - \text{Low Range}) \sqrt{(V_{\text{input}} - V_{\text{low}}) / (V_{\text{high}} - V_{\text{low}})} \right]$$

Where: Hi Range is the high end of the process variable.
 Low Range is the low end of the process variable.
 V_{input} is the actual voltage or current value of the input.
 V_{high} is the high end of the input signal range (e.g. 5 volts or 20 mA).
 V_{low} is the low end of the input signal range (e.g. 1 volt or 4 mA).

Example: Process variable range is 0 – 1000.
 Input signal range is 1–5 volts
 Input signal is 3 volts.
 Therefore, the PV will be—

$$PV = 0 + \left[(1000 - 0) \sqrt{(3-1) / (5-1)} \right] = 1000 \sqrt{.5} = 707$$

Figure 6.2
Square Root Linearization Formula

Custom Linearization

Custom linearization allows you to take virtually any nonlinear signal and linearize it using a 15-point straight line approximation curve. Typical applications are linearizing signals from nonlinear transducers, or controlling volume based on level readings for irregularly-shaped vessels. To define the function, you must enter data point pairs—the engineering units corresponding to a particular voltage or current input.

1. Press **FAST + MENU** to toggle to the **INPUT** Menu .
2. Press **MENU** to access the **LINEARIZE** parameters, and use the **▲** and **▼** keys to assign value **CUSTOM**.
3. Press **FAST + MENU** to toggle to the **CUST.LINR.** Menu
4. The parameter **1ST.INPUT** is fixed at the low end of the mA or Voltage input range.

Escape to operating mode	DISPLAY	Next parameter	MENU	Next menu	FAST + MENU	Next value	▼	or	▲
--------------------------	----------------	----------------	-------------	-----------	--------------------	------------	----------	----	----------

5. For parameter 1ST.PV, define the corresponding process variable value in engineering units.
6. For the 2ND.INPUT through XTH.INPUT (X being your last data point number), define the milliamp or voltage input of the corresponding data point.
7. For the 2ND.PV through the XTH.PV (X being your last data point number), define the milliamp or voltage input of the corresponding data point.

Once the various points are defined, the station interpolates the values between the points using a straight line relationship between the points.

Figure 6.3
Custom Linearization Curve

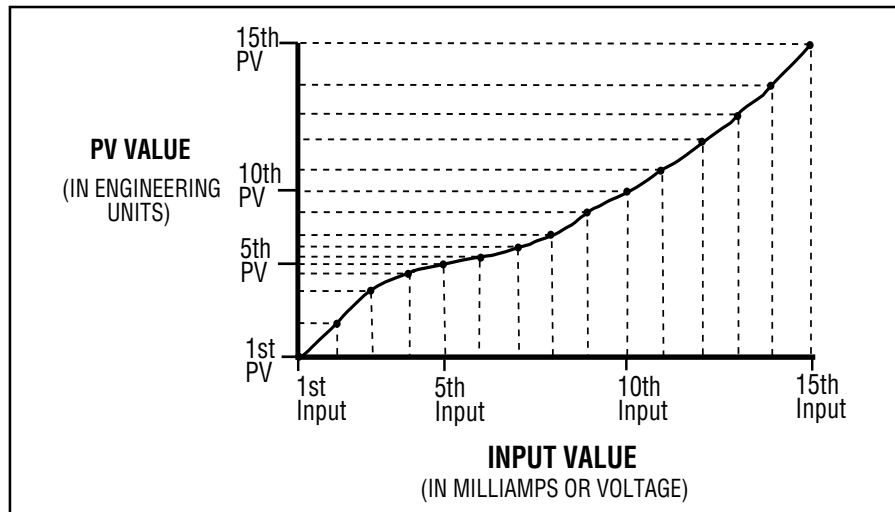

NOTE:

The resulting linearization curve must be either ever-increasing or ever-decreasing.

IMPORTANT!!

If you make any modifications to a set curve, **you must re-enter all points in order, from 1 to X.** Record the data in the Set Up Charts in Chapter 5.

RAMP TO A CONTROL VALUE

The “ramp to control value” function is useful for all other transitions where the rate-of-change of the control value must be limited, or under any circumstances where there is likely to be a significant difference between control values at the mode transition time.

Under normal operating conditions, the 531 passes the Host signal to the final control element without modification, and stores the current CV value with each cycle of the CPU. Upon loss of the Host signal (or switching out of **Host Mode**), the 531:

- Switches to **Automatic Mode** (LOST HOST = AUTO.LOCAL), automatically initiating a bumpless transfer from the last known good CV to the new PID-derived CV;
- Switches to **Manual Mode** using the last known good value from the Host (LOST HOST = MAN.LAST); or
- Switches to **Manual Mode** using one of two preset outputs (LOST HOST = MAN.OUT1 or MAN.OUT2).

Escape to operating mode	DISPLAY	Next parameter	MENU	Next menu	=FAST+ MENU	Next value	▼	or	▲
--------------------------	---------	----------------	------	-----------	-------------	------------	---	----	---

A preset output value may be considerably different from the Host CV, so the transfer may not be bumpless. The ramp to control value function allows the operator to select the ramping time for the output value change, thus smoothing the transition.

1. Press the **MENU** key to access the **OPERATIONS** Menu .
2. **MAN. RAMP** selects the ramping percentage (rate) for gradually changing output to the predefined Manual output value (when switching out of **Host Mode**).
The choices are OFF, or 0.1% to 999.9% per minute. 0.1% per minute is equal to 6.0% per hour, and 999.9% per minute is equal to 16.7% per second.
3. **HOST.RAMP** selects the ramping percentage for gradually changing output to the Host CV (when returning to **Host Mode**).
The choices are OFF, or 0.1% to 999.9% per minute. 0.1% per minute is equal to 6.0% per hour, and 999.9% per minute is equal to 16.7% per second.

SECURITY

The security function contains parameters that allow the user to lock out the selective functions of the station. Security only locks out the keypad commands — digital inputs and serial communications are not affected.

1. Press the **FAST + MENU** keys to toggle to the **SECURITY** Menu . Press **MENU** to access each of the following parameters, and the **▲** and **▼** keys to set their values.
2. **SEC. CODE**
Define the security code using the **▲** and **▼** keys. This parameter does not appear unless all functions are unlocked. The security function is compromised if the security code is left at zero (0).
3. **HOST KEY**
Selects lockout status of the **HOST** key.
4. **MAN. KEY**
Selects whether the **MANUAL** key should be LOCKED or UNLOCKED to prevent the operator from placing the 531 in **Manual Mode**. Transfer to **Manual Mode** is then accomplished by loss of Host signal, digital contact closure or Serial Communications.
5. **MAN. OUT**
Selects whether changes to the output (via the **▲** and **▼** keys) in **Manual Mode** should be LOCKED or UNLOCKED.
6. **LOCAL SP**
Selects whether changes to the setpoint (via the **▲** and **▼** keys) in any operating mode should be LOCKED or UNLOCKED.
7. **ALARM ACK.**

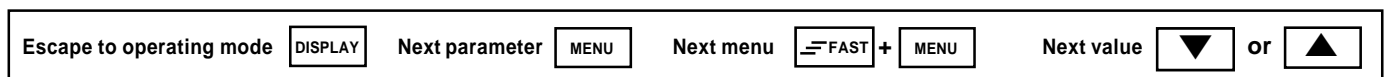

NOTE:

Be sure to set the SEC. CODE before locking any other feature. The station will not display this parameter if any others have been LOCKED. You would have to unlock all other parameters in order to view the **SEC. CODE** again.

Selects whether the **ACK** key should be LOCKED or UNLOCKED for acknowledging alarms.

8. OPERATION

Selects whether access to the OPERATIONS configuration menu should be LOCKED or UNLOCKED.

9. CONFIGURE

Selects whether changes to the other configuration parameters should be LOCKED or UNLOCKED. You must set CONFIGURE to LOCKED if you want full security. If not, the operator has access to the security code. LOCKED does allow access to the menus, but prevents changes to the parameters.

Whenever a locked function is attempted, the operator has the opportunity to enter a security code to override the lock. If the correct code is entered, the operator has full access. The security feature reactivates after one minute of keypad inactivity.

The operator also can enter the **SECURITY OVERRIDE CODE**, which, if entered correctly, resets the whole station to its default settings. The security override code is **62647**. Store this in a secure place.

Refer to Chapter 2 for details on the Security Override function.

PROCESS VARIABLE READING CORRECTION

Under certain extraneous conditions — such as an aging thermocouple, out of calibration transmitter, lead wire resistance — the station may display values other than the actual process value. To compensate for these conditions, you can set offset and gain values for the process variable.

1. Press **FAST + MENU** to toggle to the **PV INPUT** menu. Press **MENU** to access each of the following parameters, and the **▲** and **▼** keys to set values for them.

2. PV OFFSET

This either adds or subtracts a set value from the process variable reading in engineering units. For example, if your thermocouple was always reading 3° too high, you could set the PV OFFSET parameter to -3 to compensate.

3. PV GAIN

Multiplies the deviation from the low end of the process variable range by the gain factor and then adds it to the value of the low end of the range to arrive at the adjusted process variable value.

For example, if your process variable range is 50 to 650 and the process variable reading is 472, a PV GAIN of 0.995 would yield an adjusted process variable equal to $[(472 - 50) \times 0.995] + 50 = 470$.

By using a combination of both offset and gain factors, you should be able to compensate for just about any inaccuracy in your sensor or transmitter.

SERIAL COMMUNICATIONS

Serial communications is an optional feature. It enables the station to communicate

Escape to operating mode

DISPLAY

Next parameter

MENU

Next menu

FAST + MENU

Next value

▼

or

▲

with a supervisory device, such as a personal computer or programmable logic controller. The circuitry for communications is contained on a modular circuit board that plugs into the Microcontroller Circuit Board.

The station uses communications standard RS-485, which provides a multi-drop system that communicates at a high rate over long distances. Typical limitations are 32 stations per pair of wires over a distance up to 4000 feet.

The station uses a proprietary protocol which provides an extremely fast and accurate response to any command. A Cyclic Redundancy Checksum (CRC) can be enabled to ensure the integrity of any data read by the controller. Through communications, you have access to every set up and operating parameter in the station.

1. Press the **FAST + MENU** keys to toggle to the **SER.COMM.** Menu. Press **MENU** to access each of the following parameters, and use the **▲** and **▼** keys to set values for them.
2. **STATION**
Specifies the unit's station address. It is the only way one controller can be distinguished from another. Each controller on the same RS-485 interface must have a unique station address.
3. **BAUD RATE**
Choose a baud rate from 1200 to 19,200. In general, you want to select the highest baud rate. However, every station on the RS-485 interface must be set to the same baud rate.
4. **CRC**
Indicates if you are going to take advantage of the Cyclic Redundancy Checksum feature. If your host program supports it, we highly recommend that you activate it.

NOTE:

The Process Variable Reading Correction feature is provided only as a convenience. **The condition causing the erroneous reading should be corrected!**

NOTE:

PV GAIN is only available if using a linear voltage or current input.

NOTE:

For details on the station communications protocol, contact one of our application engineers.

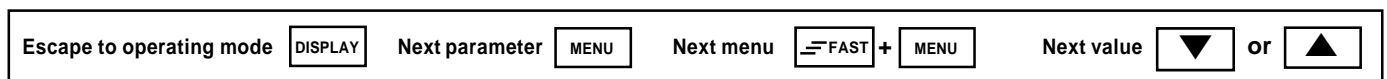

APPENDIX A MODE, MENU & PARAMETER FLOWCHART

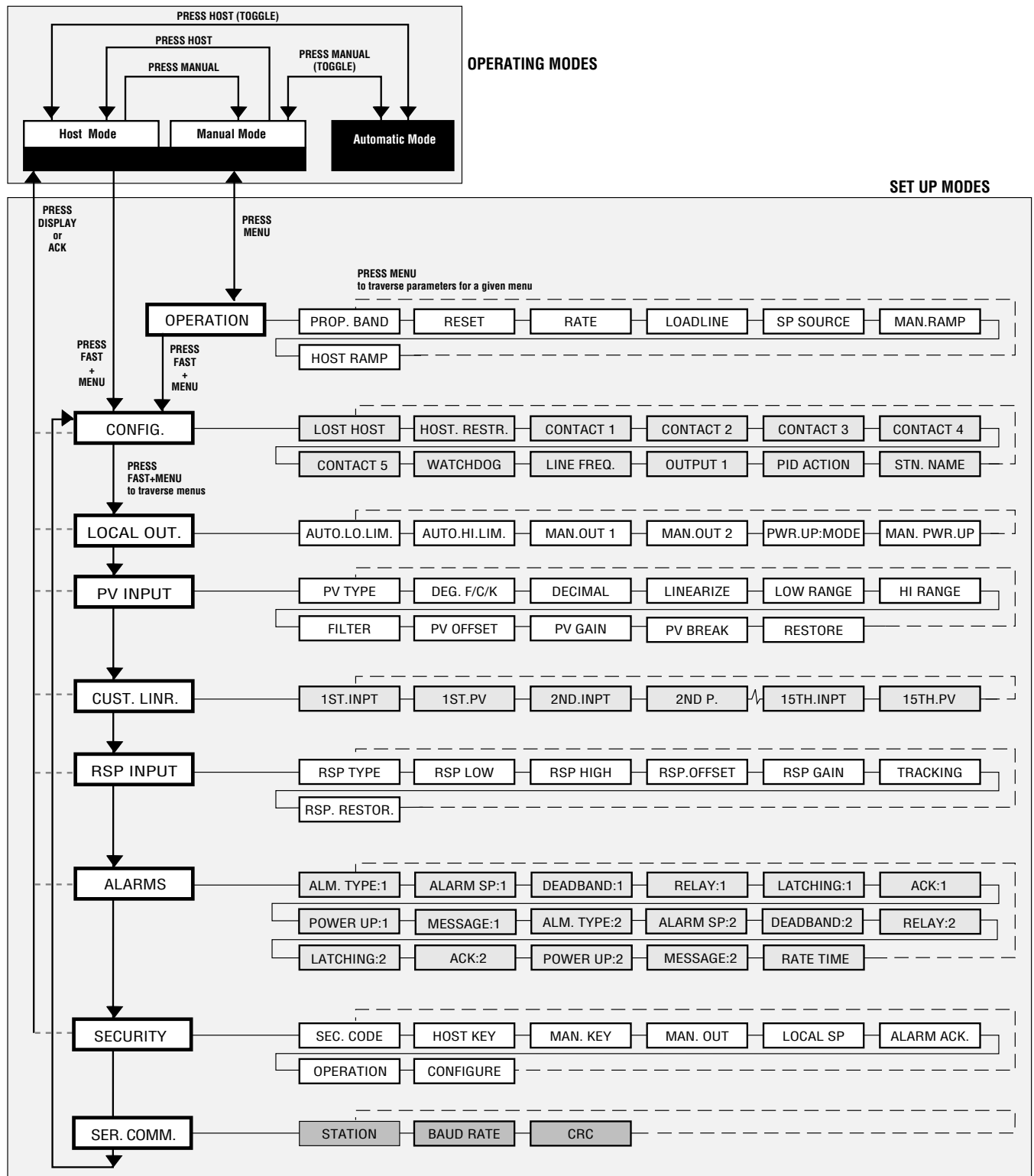

APPENDIX B PARTS LIST*

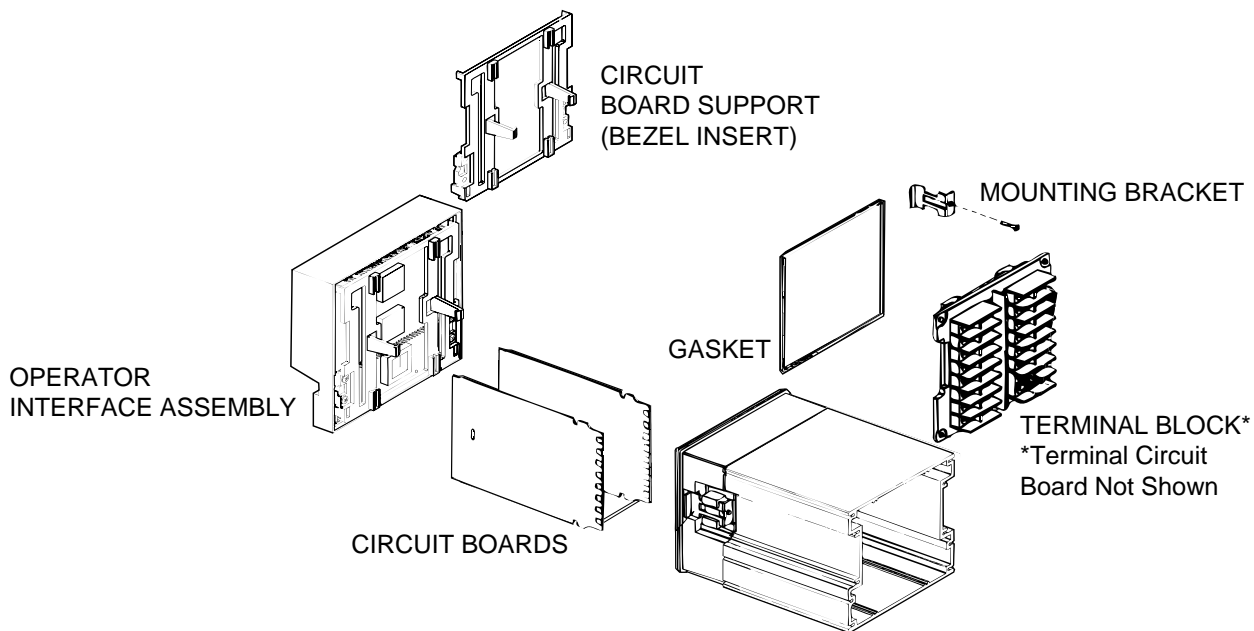

OUTPUT MODULES		Part #
1	Mechanical relay module	535 600
2	531 Analog (mA) module	532 600
4	Solid State Relay (triac) module	535 602
5	DC Logic (solid state relay drive) module	535 603
6	Loop Power Module	535 604
7	RS-485 serial communications board	535 605

REPAIR PARTS		Part #
8	Operator interface assembly 531	531 632
10	Power supply circuit board	535 630
11	Microcontroller circuit board 531	531 631
13	Option circuit board	535 620
14	Option circuit board w/5 digital inputs 531	531 621
18	EPROM 531	531 640
20	Lithium battery	093 044
21	Jumper kit (set of all jumper connectors)	535 660
22	Gasket kit (w/panel and bezel gaskets)	535 662
23	Mounting kit (including mounting brackets and screws)	532 661
24	Bezel retention screw kit	535 663
25	Module retention kit (w/retention plate & tie wrap for outputs 1-3)	535 664
26	Module retention tie wrap kit (set of 5 tie wraps)	535 665
27	Terminal block	535031A
28	Circuit board support/Bezel insert	535 025
29	Sheet of engineering unit labels	535 106
30	531 Bypass board	531 100
31	Goof plate	512 014

* For a complete list of related options and repair kits for the 531, refer to M500.

Parts List

APPENDIX C TROUBLESHOOTING

Message	When does it occur?	What to do:
DEFAULTS	Whenever the memory is cleared and all parameters revert to factory default settings. This may be done by purposely clearing the memory, when the unit is powered up for the first time, or if the software version is changed.	Changing any Set Up parameter will clear the message. If due to something other than the user purposely clearing the memory, call factory for assistance.
NEEDS CAL.	Indicates that calibration values are at factory defaults (as when a battery is replaced).	Recalibrate the unit.
LOST CAL	Indicates that the calibration data has been lost. Occurs when the memory is wiped clean.	Problem should never occur. Must correct the problem, then recalibrate. Call factory for assistance.
ERROR:ROM CHECKSUM	On power up, a problem with the ROM is detected. This is a fatal error and requires an EPROM change. Controller locks up until fixed.	Call factory for assistance.
OUT1 CONF. OUT2 CONF. OUT3 CONF. OUT4 CONF.	Upon power up, controller senses that the modules needed for control as determined by software configuration are not present.	Must power down and install correct module combination or reconfigure the controller to match the current module combination.
LOST CJC	Sensor not reading properly.	Call factory for assistance.

Troubleshooting

SYMPTOM	PROBLEM	SOLUTION
Display will not light up	Defective power source	Check power source and wiring.
	Improper wiring	Correct wiring.
	Blown in-line fuse	Check wiring, replace fuse.
	Unit not inserted in case properly; or, screws have not been tightened	Remove unit from case (and remove bezel screws), then reinsert unit and properly tighten screws.
Improper/Lost PV reading • Voltage/current	Input jumper selection improperly set	Move jumper to proper location.
	Input range improperly selected in software	Select proper range.
	Reverse polarity	Check and correct sensor wiring.
	If station powered up, improperly wired	Check and correct wiring.
	If internal supply for transmitter not installed.	Install module.
	Defective transmitter	Replace transmitter.
Improper/Lost PV reading • Thermocouple	Defective thermocouple	Replace thermocouple.
	Input jumper selection improperly set	Move jumper to proper location.
	Wrong TC type selected in software	Select proper thermocouple type in software.
	Improper wiring	Wire properly.
Improper/Lost PV reading • RTD	Defective RTD	Replace RTD.
	Input jumper selection improperly set	Move jumper to proper location.
	Improper wiring	Wire properly.
No control output	Output module not installed	Install proper output modules.
	Output wiring and module location do not match	Check and correct wiring or module location .
	If SSR, SSR Drive or Milliamp output, jumpers J1, J2 and J3 are not set properly	Move jumper to proper location (N.O.).
	Software configuration does not match hardware (OUTx CONF. message)	Reconfigure software to match hardware. See OUTx CONF. message.
Can't switch to Host control	Host CV signal is not connected or valid	Check wiring. Check that Host is supplying a valid CV signal.
Erratic display	Resetting action due to electrical noise on powerline	Filter power line.

APPENDIX D CALIBRATION

This section provides information on performing calibration for the following:

- RTD and VmA Input Calibration
- Thermocouple Cold Junction Compensation
- Milliamp Output (Standard on 531).

Access these parts of the calibration menu as shown in Figure D.1.

REGARDING CALIBRATION

To maintain optimum performance, once a year calibrate the analog input, cold junction (when a thermocouple is used) and mA Output (when used). To achieve published accuracy specifications, follow directions carefully and use calibrated instruments of like quality to those suggested. Also, if you move a station chassis into an alternate case or change its hardware configuration, and you choose to use thermocouple input, you may want to recalibrate the cold junction for optimal accuracy. Failure to do so may result in small junction temperature (not more than 0.6°C/1.1°F).

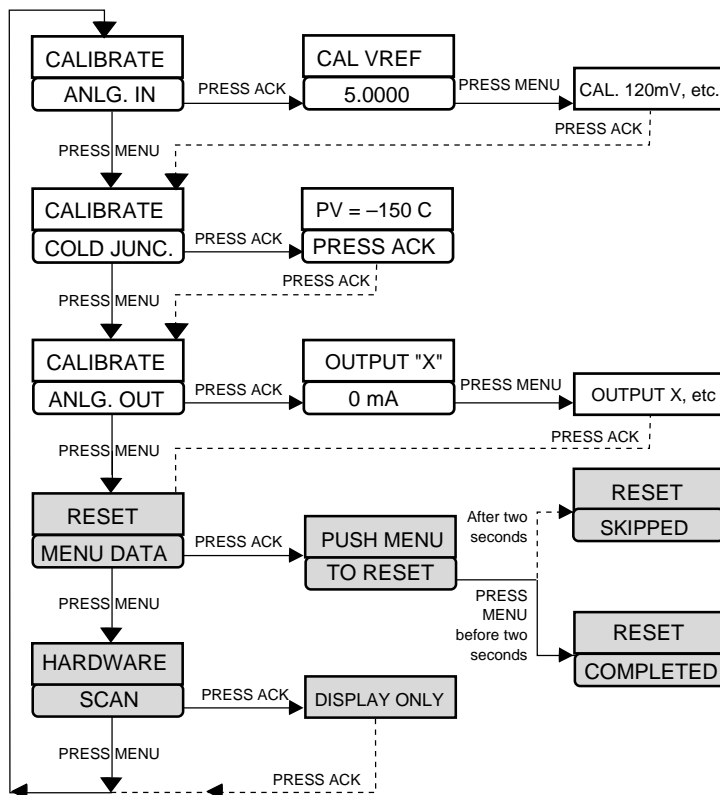

Figure D.1
Flowchart to Access Parts of
Calibration Menu Block

NOTE:
RESET, HARDWARE SCAN and S/W TEST are functions in the CALIBRATE menu; these functions are covered later in this Appendix.

ATTENTION!

The 531 comes from the factory with one milliamp output module installed in position (output) 2 and relays in position (outputs) 3 and 4. **These must not be modified.** You may install a mechanical relay, solid state relay or DC logic module in position (output) 1 for alarm functions.

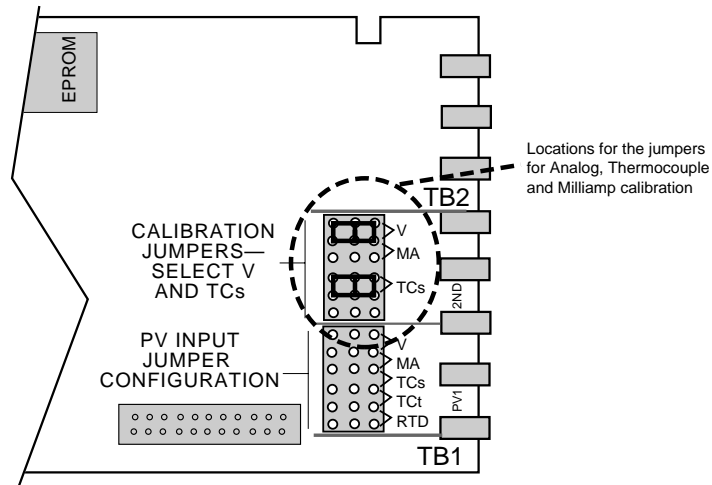

Figure D.2
Microcontroller Circuit Board

Input Calibration

Warning! Electric Shock Hazard!
Terminals 1 and 2 carry live power. **Do not touch these terminals when AC power is on.**

Equipment needed for analog input calibration:

- Precision 5-1/2 or 6-1/2 digit multimeter, such as a *Fluke 8842*[®] or *HP3478A*[®] (a 4-1/2 digit meter will sacrifice accuracy)
- Two small pieces of wire
- Test leads with clips
- #2 Phillips screwdriver

Additional equipment needed if using thermocouple input:

- Precision thermocouple calibrator, such as a *Micromite II*[®] by *Thermo Electric Instruments*
- Special limits grade, Type T thermocouple wire

1. Disconnect power to the instrument.
2. Remove chassis from case.
3. On the Microcontroller Circuit Board find jumper locations marked PV1 and 2nd near the edge connector. As shown in Figure D.2, reposition both jumper connectors in the 2nd location onto pins for V and TCs.
4. Connect the hook up wire to terminals 31 and 32 as shown in Figure D.3. The hook up wire connects to the multimeter. Set the meter for DC volts.
5. Reinsert chassis into the case and apply power. The 2nd and 3rd displays should read "CALIBRATE ANLG. IN." to show you are in the Calibrate Menu, ANLG. IN section.
6. Allow the controller to warm up for at least 30 minutes.
7. Press the ACK key to get to the first step/parameter. The 2nd display should show CAL. VREF; the 3rd display should show a value close to 5.0000.
8. The multimeter should read a value between 4.9750 and 5.0250. Press s and t keys on the controller until the display on the controller matches the meter reading (the FAST key is active if you want to scroll through the numbers more quickly).
9. Press MENU key. The 2nd display should show "CAL. 120mV" and the 3rd display should show a value close to 120.000.

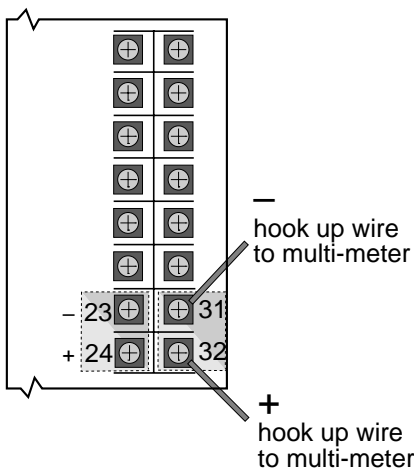

Figure D.3
Calibration Wiring

10. Repeat the sequence of steps 7, 8, and 9 four more times. Each time, you should match the displays of the controller and the multimeter. Press ACK when done. The 2nd display should show CALIBRATE; the 3rd display should show COLD JUNC.
11. Turn off power to the unit.
12. If you are using thermocouple, proceed to the Thermocouple Cold Junction Calibration Procedure.
13. For Milliamp output calibration, proceed to the Milliamp Output Calibration Procedure, where steps 1–4 can be skipped and only 10 minutes of warm up is required before proceeding to step 5.
If calibration is complete, place all the jumpers back in their original positions (as specified in Chapter 4).

Thermocouple Cold Junction Calibration

1. Add the T/C wires to terminals 31 and 32 as shown in Figure D.3a. The hook up wire connects to the multimeter. As was set for input calibration, set the meter for DC volts. Make sure the T/C wires are not connected to anything and are not touching each other.
2. Turn on power to the unit and let controller warm up for 30 minutes in the normal horizontal position: while the unit is warming up, the rear face of the controller should be vertical, not horizontal.
3. Press the MENU key until the display indicates “CALIBRATE COLD JUNC.”
4. Press the ACK key. The display should show “BASE VOLT 50.000”.
5. Connect T-Type thermocouple –150°C thermocouple calibrator to thermocouple wires on PV terminals.
6. Disconnect the hook up wires from the PV rear terminals (31 and 32) to the multimeter. Connect the thermocouple wires to the thermocouple calibrator instrument. Connect the meter test leads to the small hoops on terminals 23– and 24+ (see Figure D.4).
7. The 2nd display should show BASE VOLT. and the 3rd display should show a value close to 50.000.
8. Press s and t keys to match the controller display with the multimeter's display. Be sure that the multimeter's value is not drifting; wait until it is stable before pressing s and t keys to adjust controller display (the FAST key is active if you want to scroll through the numbers more quickly). When the value displayed on the controller matches the value on the meter, press the MENU key.
9. Disconnect the meter leads from terminals 23 and 24, and press the ACK key.
10. Test the thermocouple input to see if it is within $\pm 1^\circ\text{F}$.
11. If you will be calibrating the milliamp output, move on to the Millamp Output Calibration, #5, where steps 1–4 can be skipped and only 10 minutes of warm up is required before proceeding to step 5.
If calibration is complete, power down, then place all the jumpers in their original positions (as specified in Chapter 4).

NOTE:

In the United States, the standard negative thermocouple lead is red.

NOTE:

Do not stand the station on its front or back ends; this will disrupt accurate temperature readings.

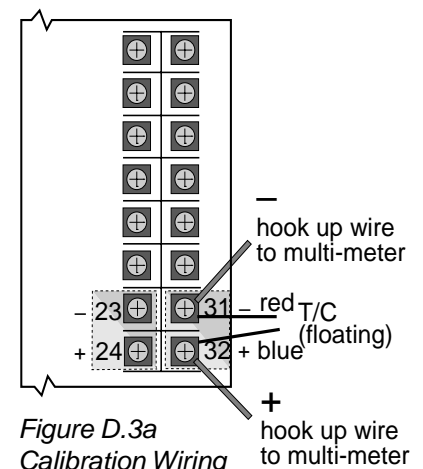

Figure D.3a
Calibration Wiring

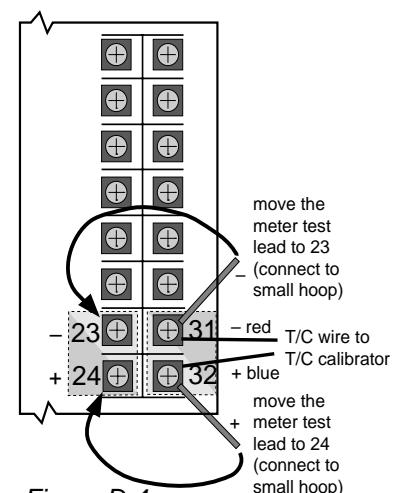

Figure D.4
Thermocouple & Cold Junction
Calibration Wiring

Calibration

NOTE:

If your multi-meter display does not register a response, check that the jumpers J1, J2 and J3 (on the Power Supply Board) are positioned as Normally Open (NO).

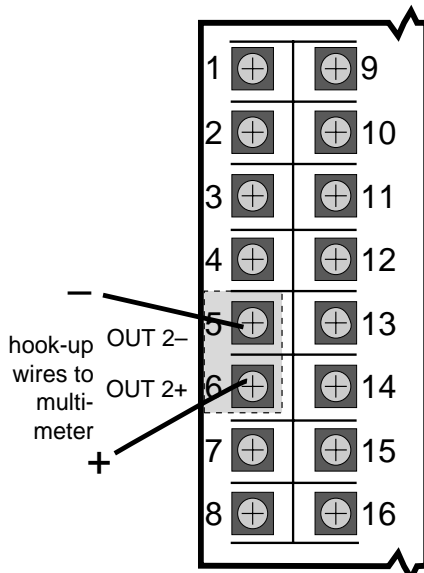

Figure D.5
Milliamp Calibration Wiring

MILLIAMP OUTPUT CALIBRATION

Once a year, calibrate the mA output to maintain optimal performance. Additionally, you should calibrate an output when a new mA module is installed.

The **531 local output** should be calibrated at terminals 5 and 6 (OUT2– and OUT2+). The bypass circuitry PC board does not have to be removed to perform the calibration.

Equipment:

- Precision 5-1/2 or 6-1/2 digit multimeter, such as a *Fluke 8842®* or *Hewlett Packard HP3478A®*
- Two small pieces of wire for each milliamp output
- Test leads with clip ends
- #2 Phillips screwdriver

1. Disconnect power to the instrument.
2. Remove chassis from case.
3. Locate jumpers marked **PV 1** and **2nd** near the edge connector of the Microcontroller Board (refer to Figure D.2). Relocate both jumper connectors so that one is positioned on the pins marked **V** of the **2nd** jumper and the other on the pins marked **TC▲** of the **2nd** jumper.
4. Connect the small pieces of wire to the terminals assigned to the milliamp output(s) you are calibrating. Figure D.5 shows the hook up wires applied to OUT2+ and OUT2–. Hook up wires need to be applied to all terminals that have corresponding milliamp output modules in their output sockets. Attach the test leads from the multimeter to the wires, and then plug the test leads into the meter. Set the meter for DC milliamperes.
5. Reinsert chassis into the case and apply power. The 2nd display should read CALIBRATE while the 3rd display reads ANLG. IN. Press MENU twice to get to the **ANLG. OUT** Menu.
6. Press **ACK**. The 2nd display will read OUTPUT 2.
7. The 3rd display should read 4 mA. Your meter should read a value close to 4.00 mA. Wait one minute. Then press and ▼ key on the station until the meter's display reads 4.00 mA. You may press **FAST** with ▲ and ▼ key to change the value at a faster rate.
8. Press **MENU**. The 3rd display should read 20 mA. Let this setting stabilize for one minute. Repeat the procedure from Step 7.
9. To complete calibration, press **ACK**, and disconnect the power. Remove the station from its case, and place the jumpers in their correct operating positions (as specified in Chapter 4).

You must press the ACK key at the end of any calibration procedure to return to the calibration menu **before powering down**.

RESET MENU DATA

Refer to Figure D.1. This function resets all parameter values back to their factory defaults (except for calibration information). Once inside this Menu Block:

1. Press **MENU** until the display shows RESET **MENU DATA**.
2. Press **ACK**.

3. The display will prompt you to press **MENU** to reset the menu data. You have two seconds to press **MENU** to accomplish the reset. If successful, RESET COMPLETED will appear in the display.
4. If you failed to press **MENU** in time, RESET SKIPPED will appear.
5. To try again, press **ACK**, and then press **MENU** within two seconds.

HARDWARE SCAN

Refer to Figure D.1. This procedure identifies the internal parts of the station. Should you need to determine the hardware inside your station, press **ACK** to enter this read-only menu. The station will display the types of output hardware and installed options.

The information displayed should match the information on the product label on top of the controller. You can compare this information to the Order Code on page 2. However, any hardware modifications will render the order code on the product label invalid.

NOTE:

Calibration data will remain intact through the Reset Menu Data function.

QUICK CALIBRATION PROCEDURE

This procedure is for the benefit of users that have ISO or other standards that require periodic calibration verification. The procedure enables verification and modification of the volt or mA process variable input you are using without entering the "Factory Configuration" mode. Therefore you do not need to perform any jumper change.

1. Power down the 531.
2. Replace the process variable (PV) input signal with a suitable calibration device.
3. Apply power and allow controller to warm up for 30 minutes.
4. Place controller under Manual control.
5. Go to the **PV INPUT**. Scroll to the PV OFFSET parameter.
5. Adjust your calibration device to an output signal equal to the 0% range value for your particular input sensor (4mA for a 4-20 mA input).
6. Verify that the value indicated in the 1st display is equal to the 0% range value for your particular input sensor. If the value is incorrect, use the **▲** and **▼** keys to scroll to the correct value.
7. Scroll to the PV GAIN parameter.
8. Adjust your calibration device to an output signal equal to the 100% range value for your particular sensor.
9. Verify value indicated in the 1st display is equal to the 100% range value for your particular input sensor. If incorrect, use the **▲** and **▼** keys to scroll to the correct value.
10. Repeat steps 3 through 8 to verify all values.
11. Return to the operating mode.

APPENDIX E SPECIFICATIONS

ACCURACY

	TYPICAL	MAXIMUM
LINEAR		
(Voltage)	± 0.025% full scale	± 0.100% full scale
(Current)	± 0.050% full scale	± 0.150% full scale
RTD		
1°	± 0.050% of span	± 0.150% of span
0.1°	± 0.095% of span	± 0.225% of span
THERMOCOUPLE		
J, K, N, E (> 0°C)	± 0.060% of span	± 0.150% of span
J, K, N, E (< 0°C)	± 0.150% of span	± 0.375% of span
T (> 0°C)	± 0.100% of span	± 0.250% of span
T (< 0°C)	± 0.250% of span	± 0.625% of span
R, S (> 500°C)	± 0.150% of span	± 0.375% of span
R, S (< 500°C)	± 0.375% of span	± 0.925% of span
B (>500°C)	± 0.150% of span	± 0.375% of span
B (<500°C)	± 0.500% of span	± 1.000% of span
W, W5 & Platinel II	± 0.125% of span	± 0.325% of span

Display accuracy is ± 1 digit. These accuracy specifications are at reference conditions (25°C) and only apply for NIST ranges. Detailed accuracy information is available upon request.

CONTROL ALGORITHM

PID, P with manual reset, PI, and PD with manual reset.

TUNING PARAMETERS

Proportional Band: 0.1 to 999% of input range
 Integral: 1 to 9999 seconds/repeat
 Derivative: 0-600 seconds
 Manual Reset: 0-100% output

ISOLATION

Inputs and outputs are grouped into the following blocks:

- Block 1** — process variable indication
- Block 2** — outputs 1, 2, and 4
- Block 3** — communications, set of 5 digital inputs, output 3
- Block 4** — setpoint and indicator

Each block is electrically isolated from the other blocks to withstand a HIPOT potential of 500 Vac for 1 minute or 600 Vac for 1 second, with the exception of blocks 1 and 4, which are isolated to withstand a HIPOT potential of 50 volts peak for 1 minute between each other. Inputs and outputs are not isolated from other inputs and outputs within the same block.

PROCESS VARIABLE INPUTS

Universal input type. Any input type may be selected in the field. Selection of input type (thermocouple, RTD, voltage or current) via jumper. Selection of particular sensor or range is via front panel.

THERMOCOUPLES	RANGE °F	RANGE °C
B	104 to 3301	40 to 1816
E	-454 to 1832	-270 to 1000
J	-346 to 1832	-210 to 1000
K	-418 to 2500	-250 to 1371
N	-328 to 2372	-200 to 1300
R	32 to 3182	0 to 1750
S	32 to 3182	0 to 1750
T	-328 to 752	-200 to 400
W	32 to 4172	0 to 2300
W5	32 to 4172	0 to 2300
Platinel II	-148 to 2550	-100 to 1399

RTD'S	RANGE °F	RANGE °C
100w Pt. (DIN)	-328 to 1562	-200 to 850
	-328.0 to 545.0	-200.0 to 285.0
100w Pt. (JIS)	-328 to 1202	-200 to 650
	-328.0 to 545.0	-200.0 to 285.0
100w Pt. (SAMA)	-328 to 1202	-200 to 650
	-328.0 to 545.0	-200.0 to 285.0

TRANSMITTER SIGNALS INPUT RANGE

Milliamps DC	4 to 20
	0 to 20
Voltage DC	1 to 5
	0 to 5
Millivolts DC	0 to 10
	0 to 30
	0 to 60
	0 to 100
	-25 to 25

LINEARIZATION

Thermocouple and RTD inputs are automatically linearized. Transmitter inputs may be linearized with a square root function or user-defineable 15-point straight line linearization function.

TRANSITION TIME

CV signal is restored 250 msec. after the HOST signal break is detected. CV signal is considered lost when it falls below 3.2 mA.

INPUT IMPEDANCE

Current Input: 250 w	Thermocouples: 10 Mw
Voltage Input: 1 Mw	RTDs: 10 Mw

UPDATE RATE

Input is sampled and output updated 5 times per second. Display is updated 5 times per second. Passage of the HOST signal through the 531 is continuous.

INPUT FILTER

Single pole lowpass digital filter with selectable time constant from 0 to 120 seconds.

Specifications

CALIBRATION

The station comes fully calibrated from the factory and continuously calibrates itself for component aging due to temperature and time, except for reference voltage. Field calibration can be performed easily with a precision multimeter and thermocouple simulator. Process variable offset and gain factors are provided to correct for sensor errors.

OUTPUT MODULES

One analog output (CV), 4–20 mA into a load up to 1000 $\bar{\omega}$. Also available is an additional mechanical relay module that can be tied to an alarm.

CONTROL OUTPUTS

4–20 mA into a load up to 1000 $\bar{\omega}$.

ALARMS

The 531 has two powerful software alarms. The 531 provides a LOCAL alarm that indicates when the 531 is in LOCAL mode. When tied to an available output, the HOST device can be flagged as to the change in status. Alternately, a PV High, PV Low, PV Rate, SP Band or SP Deviation alarm may be configured. A 9-character custom alarm message is available for each alarm.

DIGITAL INPUTS

A set of five external dry contacts or open collector driven transistor inputs are available. Each can be configured to perform one of the following functions:

- Select LOCAL control with LAST-OUT or 1 of 2 preset values
- Acknowledge alarms
- Addressable through serial communications only
- s/t Key Emulation
- HOST "watchdog" timer input

SERIAL COMMUNICATIONS

Isolated serial communications is available using an RS-485 interface. Baud rates of up to 19,200 are selectable. The protocol supports CRC data checking.

DIGITAL DISPLAYS

Displayed information depends upon chosen options.

Upper display: five-digit, seven-segment. Used exclusively to display PV. Height is 15 mm (0.6 in.).

2nd display: nine-character, 14-segment alphanumeric. Selectable SP or CV indication. During set up, displays configuration information. Height is 6 mm (0.25 in.).

3rd display: nine-character, 14-segment alphanumeric. When no alarm messages are queued, indicates a user-selectable "station" name. During set up, displays configuration information. Height is 6 mm (0.25 in.).

All displays are vacuum fluorescent. Color is blue-green.

STATUS INDICATORS

ALM 1 icon illuminated: alarm status

HOST key illuminated: CV signal from HOST is present

MANUAL key illuminated: 531 is in LOCAL MANUAL mode

ACK key illuminated: alarm is acknowledgable

MENU key illuminated: 531 is in configuration mode

DIMENSIONS

Meets 1/4 DIN designation as specified in DIN standard number 43 700. See diagram on page 5 for details.

MOUNTING

Panel-mounted. See diagram in Chapter 4 for details.

WIRING CONNECTIONS

30 screw terminals in the rear of the instrument.

POWER CONSUMPTION

15 VA at 120 VAC, 60 Hz (typical).

WEIGHT

Approximately 1 kg (2.2 lbs.).

AMBIENT TEMPERATURE

Operative Limits: 0 to 50°C (32 to 122°F).

Storage Limits: –40 to 70°C (–40 to 158°F).

RELATIVE HUMIDITY

10 to 90%, non-condensing.

VOLTAGE AND FREQUENCY

Universal power supply: 90 to 250 VAC, 48 to 62 Hz.

NOISE IMMUNITY

Common mode rejection (process input): >120 dB.

Normal mode rejection (process input): >80 dB.

AC line is double filtered and transient protected. Internal snubbers are provided for each relay output.

CONSTRUCTION

Case: extruded, non-perforated black anodized aluminum with ABS plastic sleeve.

Bezel: black plastic ABS.

Chassis assembly: plug-in type.

Keys: silicone rubber with diffusion printed graphics.

NEMA rating: front panel conforms to NEMA 4X when instrument is properly installed.

AGENCY APPROVALS



LISTED
Process Control Equipment
4N66



(Heavy Industrial)

(Available as an option)

MEMORY RETENTION

Lithium battery maintains all programming for approximately ten years.

SECURITY

There are two levels of access: restricted and full. A configurable code is used to enter the full access level. Functions not available in the restricted level are configurable.

RETURN PROCEDURES

To return equipment to Moore Industries for repair, follow these four steps:

1. Call Moore Industries and request a Returned Material Authorization (RMA) number.

Warranty Repair –

If you are unsure if your unit is still under warranty, we can use the unit's serial number to verify the warranty status for you over the phone. Be sure to include the RMA number on all documentation.

Non-Warranty Repair –

If your unit is out of warranty, be prepared to give us a Purchase Order number when you call. In most cases, we will be able to quote you the repair costs at that time. The repair price you are quoted will be a "Not To Exceed" price, which means that the actual repair costs may be less than the quote. Be sure to include the RMA number on all documentation.

2. Provide us with the following documentation:
 - a) A note listing the symptoms that indicate the unit needs repair
 - b) Complete shipping information for return of the equipment after repair
 - c) The name and phone number of the person to contact if questions arise at the factory
3. Use sufficient packing material and carefully pack the equipment in a sturdy shipping container.
4. Ship the equipment to the Moore Industries location nearest you.

The returned equipment will be inspected and tested at the factory. A Moore Industries representative will contact the person designated on your documentation if more information is needed. The repaired equipment, or its replacement, will be returned to you in accordance with the shipping instructions furnished in your documentation.

WARRANTY DISCLAIMER

THE COMPANY MAKES NO EXPRESS, IMPLIED OR STATUTORY WARRANTIES (INCLUDING ANY WARRANTY OF MERCHANTABILITY OR OF FITNESS FOR A PARTICULAR PURPOSE) WITH RESPECT TO ANY GOODS OR SERVICES SOLD BY THE COMPANY. THE COMPANY DISCLAIMS ALL WARRANTIES ARISING FROM ANY COURSE OF DEALING OR TRADE USAGE, AND ANY BUYER OF GOODS OR SERVICES FROM THE COMPANY ACKNOWLEDGES THAT THERE ARE NO WARRANTIES IMPLIED BY CUSTOM OR USAGE IN THE TRADE OF THE BUYER AND OF THE COMPANY, AND THAT ANY PRIOR DEALINGS OF THE BUYER WITH THE COMPANY DO NOT IMPLY THAT THE COMPANY WARRANTS THE GOODS OR SERVICES IN ANY WAY.

ANY BUYER OF GOODS OR SERVICES FROM THE COMPANY AGREES WITH THE COMPANY THAT THE SOLE AND EXCLUSIVE REMEDIES FOR BREACH OF ANY WARRANTY CONCERNING THE GOODS OR SERVICES SHALL BE FOR THE COMPANY, AT ITS OPTION, TO REPAIR OR REPLACE THE GOODS OR SERVICES OR REFUND THE PURCHASE PRICE. THE COMPANY SHALL IN NO EVENT BE LIABLE FOR ANY CONSEQUENTIAL OR INCIDENTAL DAMAGES EVEN IF THE COMPANY FAILS IN ANY ATTEMPT TO REMEDY DEFECTS IN THE GOODS OR SERVICES. BUT IN SUCH CASE THE BUYER SHALL BE ENTITLED TO NO MORE THAN A REFUND OF ALL MONIES PAID TO THE COMPANY BY THE BUYER FOR PURCHASE OF THE GOODS OR SERVICES.

ANY CAUSE OF ACTION FOR BREACH OF ANY WARRANTY BY THE COMPANY SHALL BE BARRED UNLESS THE COMPANY RECEIVES FROM THE BUYER A WRITTEN NOTICE OF THE ALLEGED DEFECT OR BREACH WITHIN TEN DAYS FROM THE EARLIEST DATE ON WHICH THE BUYER COULD REASONABLY HAVE DISCOVERED THE ALLEGED DEFECT OR BREACH, AND NO ACTION FOR THE BREACH OF ANY WARRANTY SHALL BE COMMENCED BY THE BUYER ANY LATER THAN TWELVE MONTHS FROM THE EARLIEST DATE ON WHICH THE BUYER COULD REASONABLY HAVE DISCOVERED THE ALLEGED DEFECT OR BREACH.

RETURN POLICY

For a period of thirty-six (36) months from the date of shipment, and under normal conditions of use and service, Moore Industries ("The Company") will at its option replace, repair or refund the purchase price for any of its manufactured products found, upon return to the Company (transportation charges prepaid and otherwise in accordance with the return procedures established by The Company), to be defective in material or workmanship. This policy extends to the original Buyer only and not to Buyer's customers or the users of Buyer's products, unless Buyer is an engineering contractor in which case the policy shall extend to Buyer's immediate customer only. This policy shall not apply if the product has been subject to alteration, misuse, accident, neglect or improper application, installation, or operation. THE COMPANY SHALL IN NO EVENT BE LIABLE FOR ANY INCIDENTAL OR CONSEQUENTIAL DAMAGES.



WORLDWIDE • www.miinet.com

United States • info@miinet.com Tel: (818) 894-7111 • FAX: (818) 891-2816	Belgium • info@mooreind.be Tel: 03/448.10.18 • FAX: 03/440.17.97	China • sales@mooreind.sh.cn Tel: 86-21-62491499 • FAX: 86-21-62490635
Australia • sales@mooreind.com.au Tel: (02) 8536-7200 • FAX: (02) 9525-7296	The Netherlands • sales@mooreind.nl Tel: (0)344-617971 • FAX: (0)344-615920	United Kingdom • sales@mooreind.com Tel: 01293 514488 • FAX: 01293 536852

5 3 1



5 3 1

1/4 DIN PID BACKUP STATION
ADDENDUM TO THE USER'S MANUAL

 [®]
**MOORE
INDUSTRIES**

The 531 controller has been upgraded with a new microprocessor, new case, and modifications to the front panels to improve its NEMA 4x capability. Insert the information in this addendum where appropriate in your M531 V5 manual.

Cover

The 500 series controller body has been modified to a 1-piece design, with a new face plate (4 screws instead of 2 securing it to the body).



Chapter 1, Page 1, Figure 1.1
also
Chapter 2, Page 5, Figure 2.1
Chapter 2, Page 8, Figure 2.2
Chapter 4, Page 15, Figure 4.1

This drawing shows a basic detail of the new faceplate. Please refer to this drawing for any detail of the controller face.

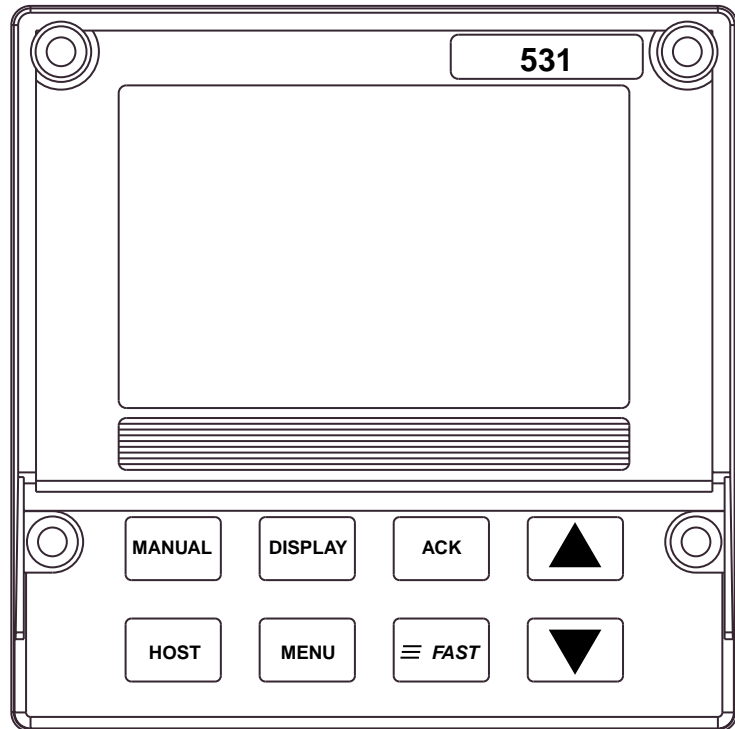

531 - 2 1 1 B 0 0

Output 1: Alarm Order Code
 None 0
 Mechanical Relay 1
 Solid State Relay (triac) (1 amp) 3
 DC Logic (SSR drive) 4

Options
 Enter "0" if not desired
 24 VAC/24VDC Operation F

Set of Five Digital Inputs D
 CE Certification H
 Five Digital Inputs and CE Certification J

Serial Communications
 Enter "0" if not desired
 RS-485 Serial Communications S

Base instrument contains universal PV input, remote setpoint input, and 4–20 mA CV (control) output with internal hard-wired bypass relays.

Chapter 3, Page 9, Figure 3.1

This drawing has been modified (due to the new controller body).

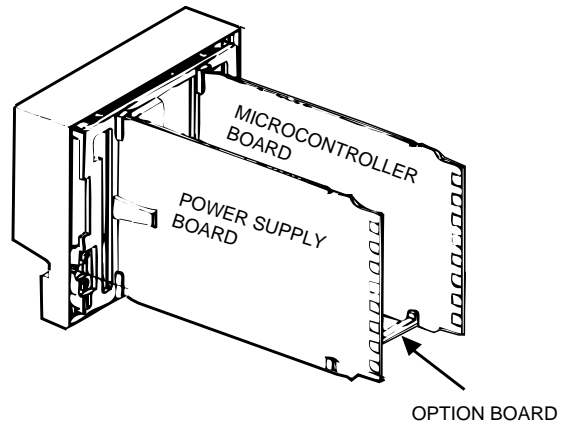

Chapter 3, Page 10, Figure 3.2

The Microcontroller Board has been modified.

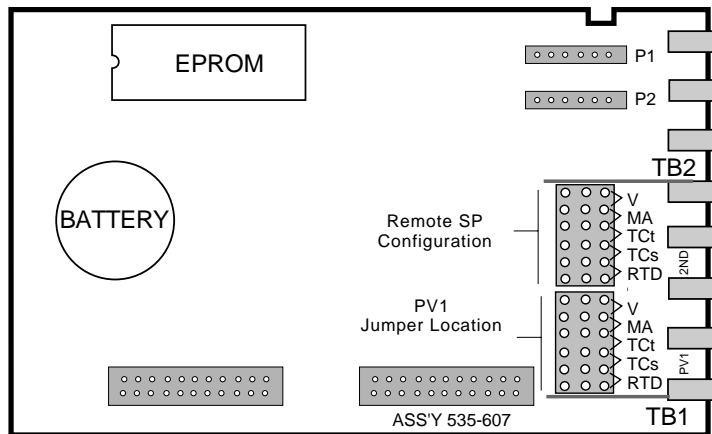

Chapter 4, Page 16, Figure 4.2

A mounting collar replaces the old mounting brackets.

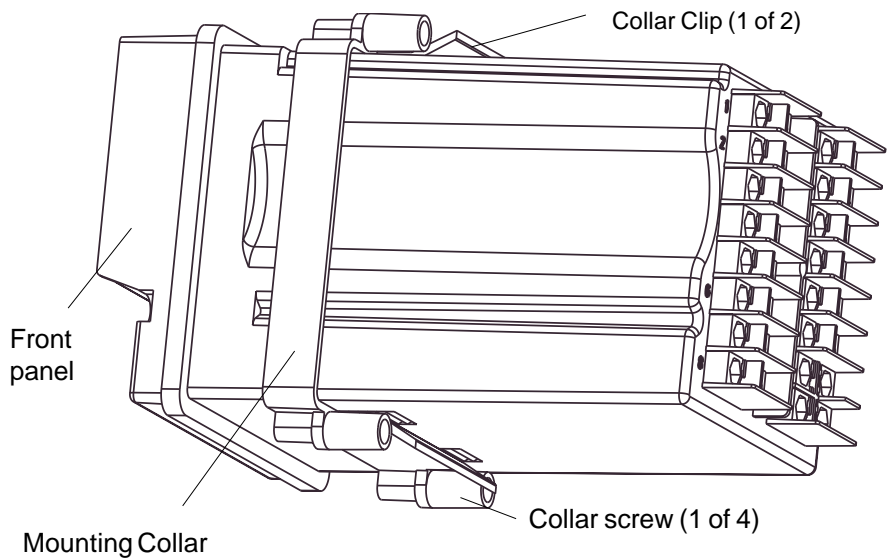

Chapter 4, Page 16

- 2c. Slide the mounting collar over the back of the case. The collar clip edges will lock with matching edges on the controller case.
- 2d. Insert the four mounting collar screws from the rear of the collar. Gradually tighten the screws to secure the controller against the panel.

Chapter 5, Page 25

In the **CONFIG** Menu, add the following new parameter after **HOST RESTR**.

3. **CV RANGE**
Selects the CV output signal.
- (D) 4-20mA
- 20-4mA

Chapter 5, Page 33

All following parameters are renumbered accordingly.

In the **ALARMS** Menu: two new alarm types have been added, the respective alarm setpoint parameters have been modified, and four new setpoint parameters (2 per alarm) have been added.

1. ALM. TYPE:1

- (D) OFF
- LOCAL
 - HIGH PV
 - LOW PV
 - RATE
 - BAND
 - DEVIATION
 - HIGH CV
 - LOW CV
 - HI/LO CV Separate High and Low CV setpoints
 - HI/LO PV Separate High and Low PV setpoints

2. ALARM SP:1

Specifies the alarm set point for alarm 1.

- | | |
|--------------------|-------------------------------|
| For RATE alarms: | For HIGH CV or LOW CV alarms: |
| (R) -9999 to 99999 | (R) 0.0 to 100.0% |
| (D) 0 | (D) 0.0% |

For any other type (except HI/LO CV or HI/LO PV)

- (R) The PV range
- (D) Dependent on LOW RANGE value

3. HIGH SP:1

Specifies the high alarm set point for HI/LO CV or HI/LO PV alarm 1.

- | | |
|----------------------|---------------------------|
| For HI/LO CV alarms: | For HI/LO PV alarms: |
| (R) 0.0% to 100.0% | (R) LOW RANGE to HI RANGE |
| (D) 0.0% | (D) 0 |

4. LOW SP:1

Specifies the low alarm set point for HI/LO CV or HI/LO PV alarm 1.

For HI/LO CV alarms:

(R) 0.0% to 100.0%

(D) 0.0%

For HI/LO PV alarms:

(R) LOW RANGE to HI RANGE

(D) 0

11. ALM. TYPE:2

(D) OFF

- LOCAL
- HIGH PV
- LOW PV
- RATE
- BAND
- DEVIATION
- HIGH CV
- LOW CV
- HI/LO CV Separate High and Low CV setpoints
- HI/LO PV Separate High and Low PV setpoints

12. ALARM SP:2

Specifies the alarm set point for alarm 2.

For RATE alarms:

(R) -9999 to 99999

(D) 0

For HIGH CV or LOW CV alarms:

(R) 0.0 to 100.0%

(D) 0.0%

For any other type (except HI/LO CV or HI/LO PV)

(R) The PV range

(D) Dependent on LOW RANGE value

13. HIGH SP:2

Specifies the high alarm set point for HI/LO CV or HI/LO PV alarm 2.

For HI/LO CV alarms:

(R) 0.0% to 100.0%

(D) 0.0%

For HI/LO PV alarms:

(R) LOW RANGE to HI RANGE

(D) 0

14. LOW SP:2

Specifies the low alarm set point for HI/LO CV or HI/LO PV alarm 2.

For HI/LO CV alarms:

(R) 0.0% to 100.0%

(D) 0.0%

For HI/LO PV alarms:

(R) LOW RANGE to HI RANGE

(D) 0

CONFIG

Parameter	Description	Values
1 LOST HOST	Defines fundamental controller Set Up	
2 HOST. RESTR.	Defines the power source frequency	
3 CV RANGE	Specifies the CV output signal	
4 CONTACT 1	Operation of the first digital input	
5 CONTACT 2	Operation of the second digital input	
6 CONTACT 3	Operation of the third digital input	
7 CONTACT 4	Operation of the fourth digital input	
8 CONTACT 5	Operation of the fifth digital input	
9 WATCHDOG	Defines function of Host watchdog monitor	
10 LINE FREQ.	Specifies the power source frequency	
11 OUTPUT 1	Defines the function of the 1st output	
12 PID ACTION	Selects the PID control action	
13 STN. NAME	Specifies a 9-character message to name the station	

ALARMS

Parameter	Description	Value
1 ALM. TYPE:1	Type of alarm for alarm 1	
2 ALARM SP:1	Alarm setpoint alarm 1	
3 HIGH SP:1	High alarm setpoint for HI/LO CV or HI/LO PV alarm 1	
4 LOW SP:1	Low alarm setpoint for HI/LO CV or HI/LO PV alarm 1	
5 DEADBAND:1	Dead band for alarm 1	
6 RELAY:1	State of the relay for alarm 1	
7 LATCHING:1	Latching sequence for alarm 1	
8 ACK.:1	Whether alarm 1 may be acknowledged	
9 POWER UP:1	How alarm 1 will be treated upon power up	
10 MESSAGE:1	Nine character message associated with alarm 1	
11 ALM. TYPE:2	Type of alarm for alarm 2	
12 ALARM SP:2	Alarm setpoint alarm 2	
13 HIGH SP:2	High alarm setpoint for HI/LO CV or HI/LO PV alarm 2	
14 LOW SP:2	Low alarm setpoint for HI/LO CV or HI/LO PV alarm 2	
15 DEADBAND:2	Dead band for alarm 2	
16 RELAY:2	State of the relay for alarm 2	
17 LATCHING:2	Latching sequence for alarm 2	
18 ACK.:2	Whether alarm 2 may be acknowledged	
19 POWER UP:2	How alarm 2 will be treated upon power up	
20 MESSAGE:2	Nine character message associated with alarm 2	
21 RATE TIME	Time period over which a rate-of-change is determined	

After LOW CV, insert these two new alarm types:

HI/LO CV

Combination of high and low CV alarms. Occurs when the PV exceeds the individually set high or low CV setpoint.

HI/LO PV

Combination of high and low PV alarms. Occurs when the PV exceeds the individually set high or low setpoint.

The Menu Flowchart has been modified accordingly:

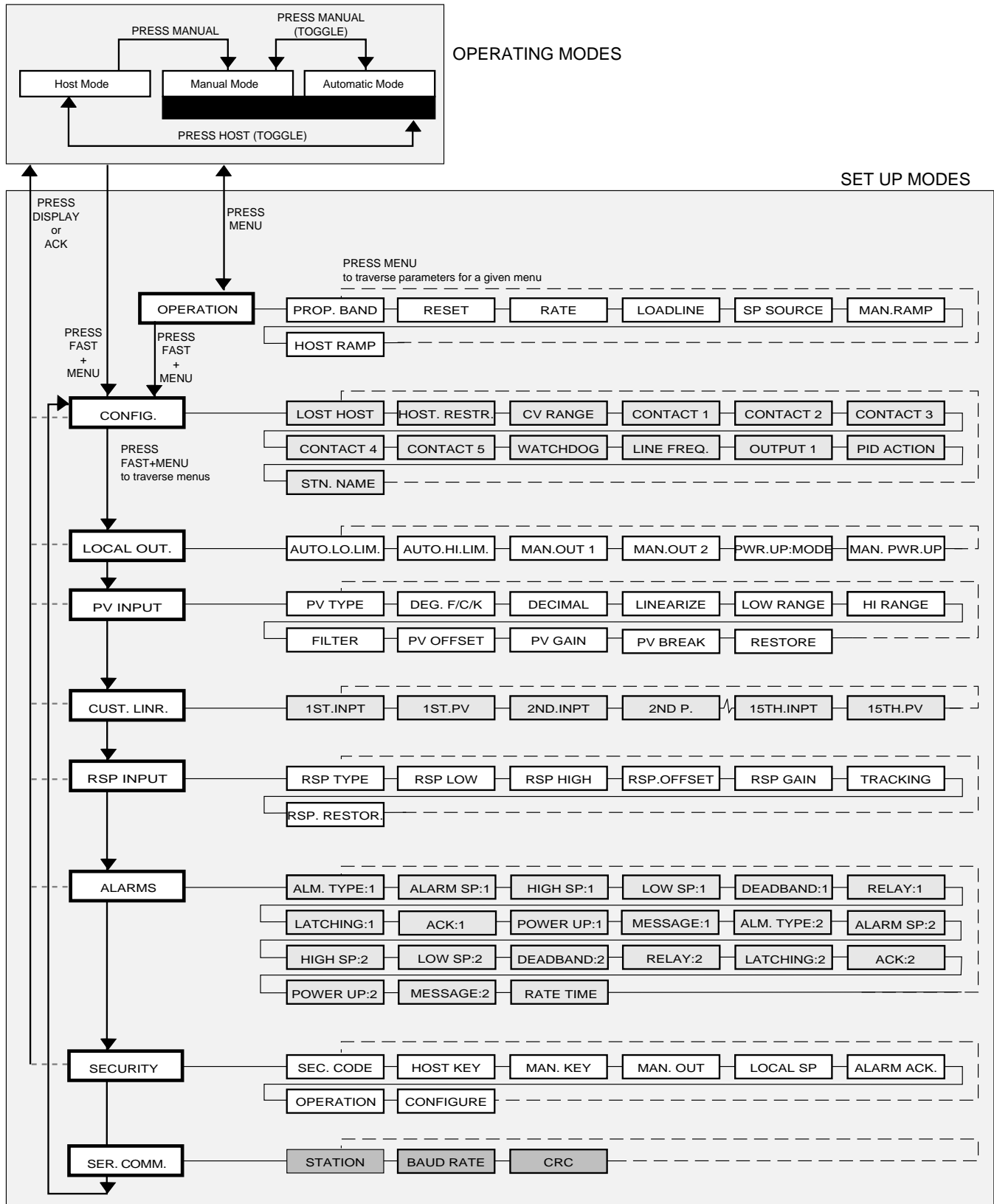

Appendix B, Page B-1

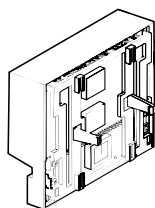

OPERATOR
INTERFACE
ASSEMBLY
shown with bezel
insert in place

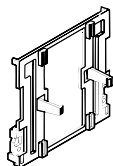

CIRCUIT
BOARD SUPPORT
(BEZEL INSERT)

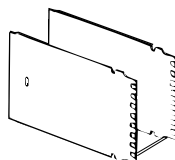

CIRCUIT BOARDS



BEZEL
GASKET

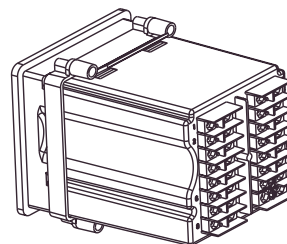

CONTROLLER BODY
shown with mounting
collar in place

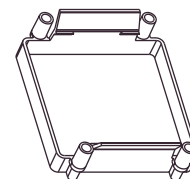

MOUNTING
COLLAR

With the modifications to the case and addition of the mounting collar, the parts drawings have been modified. Also, note the new part numbers.

ITEM	PART #
Output Modules	
Mechanical Relay Module	535 600
Analog (Milliamp Module)	535 601
Solid State Relay Module	535 602
DC Logic (SSR Drive) Module	535 603
Loop Power Module	535 604
RS-485 Communications Module	535 705
Repair/Replacement Parts	
Operator Interface Assembly	531 632
Power Supply Circuit Board	535 730
Microcontroller Circuit Board	535 731
Option Circuit Board w/no Options	535 720
Option Circuit Board w/Set of 5 Digital Contacts	535 721
EPROM 531	531 740
Lithium Battery	093 044
Jumper Kit: Set of All Jumper Connectors	535 660
Gasket Kit: 1 Panel Gasket & 1 Bezel Gasket	535 662
Mounting Kit: Mounting Collar & 4 screws	535 761
Bezel Retention Screw Kit	535 663
Module Retention Kit for Outputs 1-3 (Includes Retention Plate)	535 664
Module Retention Kit for Output 4: Set of 5 Tie Wraps	535 665
Circuit Board Support (Bezel Insert)	535 075
Engineering unit labels (1 sheet)	535 106
531 Bypass board	532 100

Message	When does it occur?	What to do:
DEFAULTS	Whenever the memory is cleared and all parameters revert to factory default settings. This may be done by purposely clearing the memory or when the unit is powered up for the first time or if the software version is changed.	Changing any Set Up parameter will clear the message. If due to something other than the user purposely clearing the memory, call factory for assistance.
LOST CAL. or ERROR: BAD CAL. DATA	Indicates that the calibration data has been lost. Occurs when there is a total loss of memory.	Problem should never happen. Must correct the situation and recalibrate. Call factory for assistance.
ERROR: ROM CHECKSUM	On power up, a problem with the EPROM is detected. Controller locks up until fixed.	Call factory for assistance.
OUT1 CONF or OUT2 CONF or OUT3 CONF or OUT4 CONF	Upon power up, controller senses that the modules needed for control as determined by software configuration are not present.	Must power down and install correct module combination or must reconfigure the controller to match the current module combination.
LOST CJC	The cold junction is sensed as lost.	Call factory for assistance.
ERROR: BAD EEPROM	During power up an EEPROM failure is detected. Controller locks up until fixed.	This is a fatal error and requires and EEPROM change. Call factory for assistance.
NEEDS CAL.	When the controller is powered up with default calibration data (input and output accuracy specifications may be met).	Enter calibration menu and recalibrate the controller. Call factory for assistance.
ERROR: BAD MODEL NUM.	During power up, a discrepancy was found between the EEPROM's and controller's model numbers. Controller locks up until fixed.	This is a fatal error and requires an EPROM or EEPROM change. Call factory for assistance.

The following pages replace Appendix D of the 531 manual.

APPENDIX D CALIBRATION

- To maintain optimum performance, once a year calibrate the analog input, the cold junction and milliamp output (when used). To achieve published accuracy specifications, follow directions carefully and use calibrated instruments of like quality to those suggested.
- If the controller is moved into an alternate case, or the hardware configuration is changed, and the thermocouple input is needed, recalibrate the cold junction for maximum accuracy. Failure to do so may result in small junction temperature (0.6°C/1.1°F).

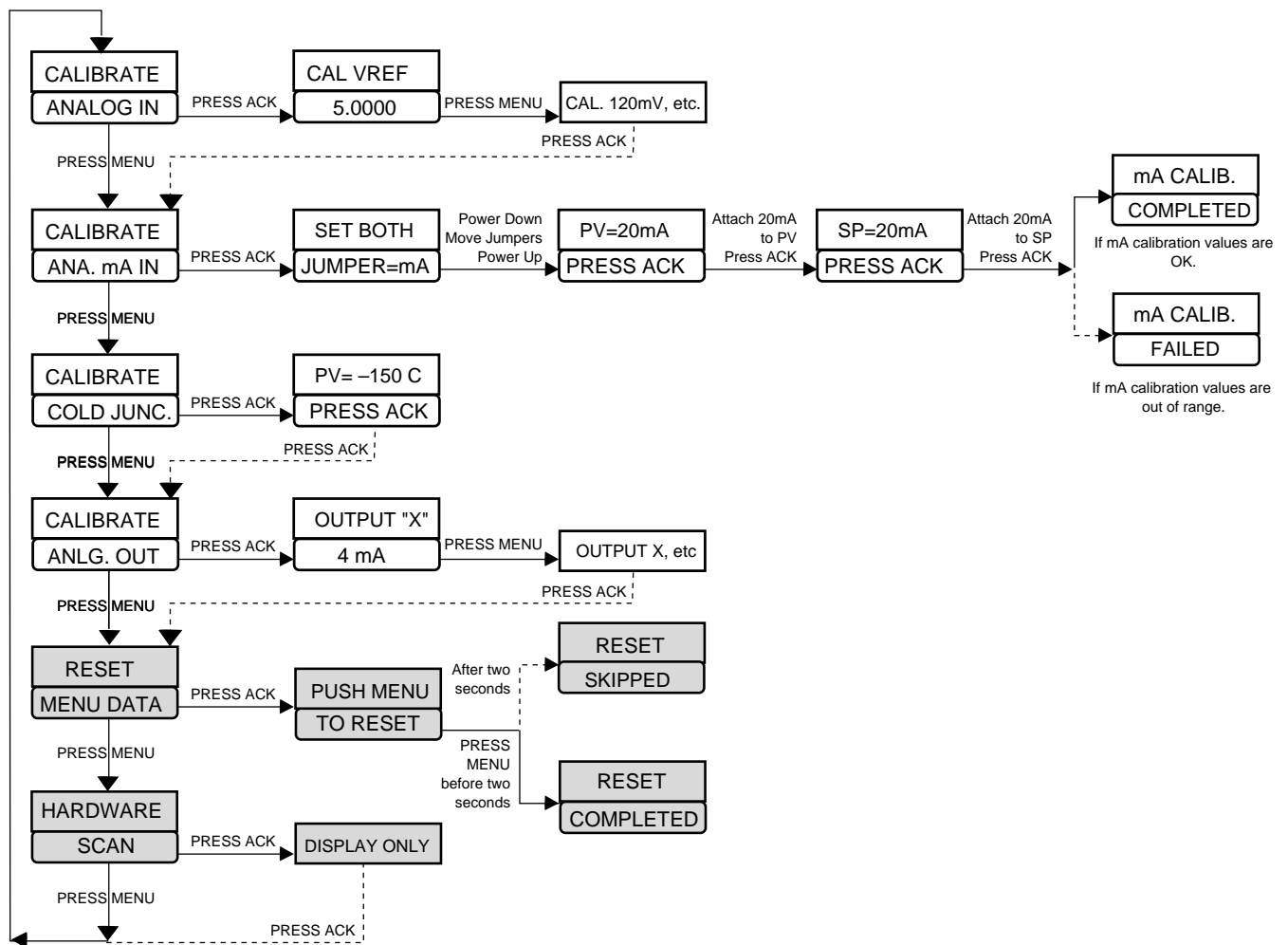

Access the parts of the calibration menu as shown in *Figure D.1*.

ATTENTION!

The 531 comes from the factory with one milliamp output module installed in position (output) 2 and relays in position (outputs) 3 and 4. **These must not be modified.** You may install a mechanical relay, solid state relay or DC logic module in position (output) 1 for alarm functions.

Figure D.2
Microcontroller Circuit Board

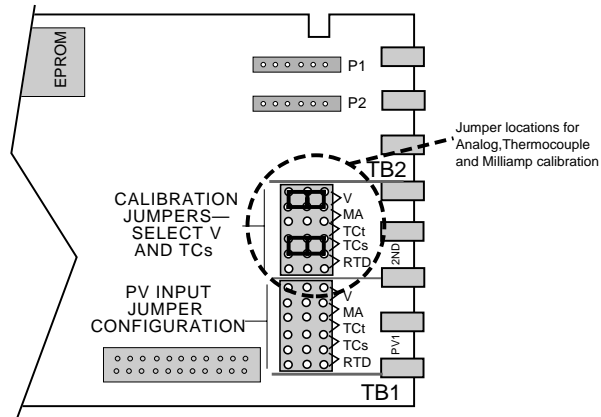

PREPARATION FOR ALL INPUT CALIBRATIONS

Equipment for analog input calibration:

- Precision 5-1/2 or 6-1/2 digit multimeter, e.g., Fluke 8842® or HP3478A® (a 4-1/2 digit meter will sacrifice accuracy)
- Four small pieces of wire
- Test leads with clips
- #2 Phillips screwdriver

Additional equipment for thermocouple input:

- Precision thermocouple calibrator, e.g., Micromite II® by Thermo Electric Instruments
- Special limits grade, Type T thermocouple wire

1. Disconnect power to the instrument.
2. Remove chassis from case.
3. On the Microcontroller Circuit Board, locate jumper locations marked **PV1** and **2nd** near the edge connector. Reposition both jumper connectors in the 2nd location onto pins for **V** and **TC▲** as shown in *Figure D.2*.
4. Connect hook up wires between terminals 31 and 32 as shown in *Figure D.3*, and the multimeter.

Set the meter for **DC volts**.

5. Reinsert chassis into the case and apply power.
The 2nd and 3rd display should read CALIBRATE ANALOG IN.
6. Allow the controller to warm up for at least 30 minutes.
7. Press the **ACK** key to get to the first step/parameter.
The 2nd display should show CAL. VREF; the 3rd display should show a value close to 5.0000.
8. The multimeter should read a value in the range 4.9750 - 5.0250.
Use the **▲** and **▼** (and **FAST**) keys on the controller until the display on the controller matches the meter reading.
9. Press **MENU** key.
The 2nd display should show CAL. 120mV. The 3rd display should show a value close to 120.000. Match controller display to multimeter value using **▲** and **▼** keys.

WARNING! Electric Shock Hazard!
Terminals 1 and 2 carry live power.
Do not touch these terminals when
AC power is on.

Figure D.3
Input Calibration

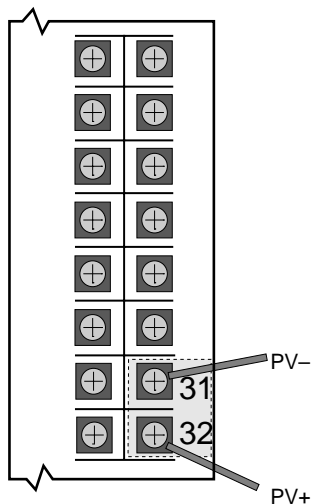

10. Press **MENU** four more times. Each time, match the displays of the controller and the multimeter. Press **ACK** when done.
The 2nd display should show CALIBRATE; the 3rd display should show ANA. mA IN.
11. Turn off power to the unit.
12. For **thermocouple input**, proceed to the Thermocouple Cold Junction Calibration.
13. For **milliamp input**, proceed to Analog Milliamp Input Calibration.
14. For **milliamp output calibration**, let the controller warm up for 10 minutes, then skip to step 5 of Milliamp Output Calibration.
15. If **calibration is complete**, place all the jumpers back in their original positions (as specified in Chapter 3).

THERMOCOUPLE COLD JUNCTION CALIBRATION

1. Connect the two pairs of T/C wire to terminals 31 and 32 as shown in *Figure D.4*. Make sure the T/C wires are floating (disconnect from the multimeter also), and are not touching each other.
2. Turn on power to the unit and let controller warm up for 30 minutes in the normal horizontal position: while the unit is warming up, the rear face of the controller should be vertical, not horizontal.
3. Press the **MENU** key until the display indicates CALIBRATE COLD JUNC.
4. Press the **ACK** key. The display should show PV = -150 C PRESS ACK.
5. Connect both pairs of T/C wires in parallel—do not daisy chain—to a Type T thermocouple calibrator. (Both pairs must be connected or the calibration will not be accurate.)
6. Set the thermocouple calibrator to an output value of -150° C for a Type T thermocouple and allow the calibrator to stabilize for a few minutes.
7. Press **ACK** to initiate calibration of the cold junction.
8. For **milliamp output calibration**, proceed to Milliamp Output Calibration. Let the controller warm up for 10 minutes, then skip to step 5.
9. If **calibration is complete**, power down, then place all the jumpers in their original positions (as specified in Chapter 3).

ANALOG MILLIAMP INPUT CALIBRATION

1. Remove the thermocouple wires (if present) from terminals 31 and 32. Replace them with pieces of wire that will be connected to a 20 milliamp input current (see *Figure D.5*). Make sure terminal screws are securely tightened, but do not connect the wires yet (leave inputs floating).
2. Turn on power to the unit.
3. Press **MENU** until the display indicates CALIBRATE ANA. mA IN, then press **ACK**.
If the display shows PV=20mA PRESS ACK, move ahead to step #8.
4. The controller will display SET BOTH JUMPER=mA.
5. Power down the controller and remove chassis from the case.

Figure D.4
Thermocouple Cold Junction Calibration Wiring

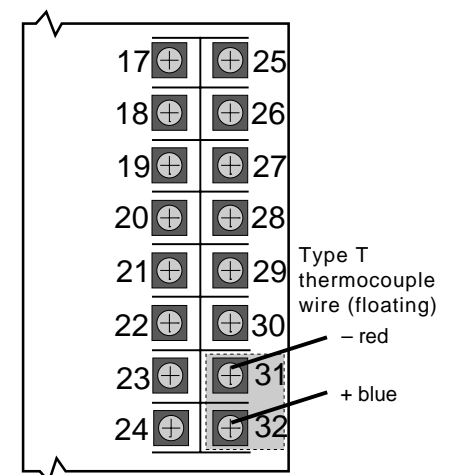

Figure D.5
Analog mA Input Calibration

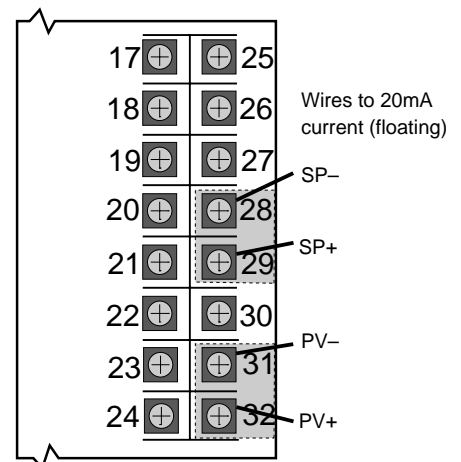
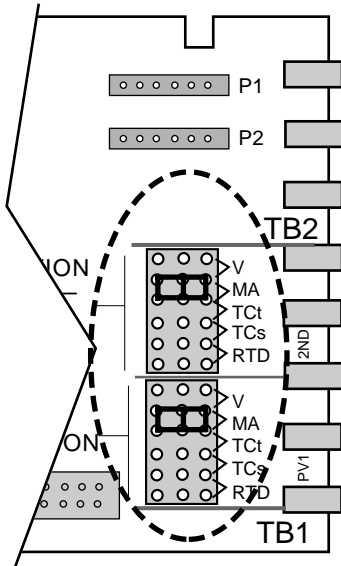

Figure D.6
Analog mA Input Jumper Position



6. Remove both input jumper connectors from the pins in the 2nd position. Place one of the jumpers on the PV1 position **mA** pins, and place the other jumper on the 2nd position **mA** pins, as shown in *Figure D.6*.
7. Reinsert the chassis into the case and apply power. The controller should display PV=20mA PRESS ACK to indicate it is ready to calibrate the PV milliamp input.
8. Connect a precision 20mA input to the PV terminals (31 is PV-, 32 is PV+). Make sure the terminal connections are fastened tightly and that a 20mA current is flowing through PV. **Do not** connect the 20mA current to SP yet.
9. Let the controller warm up for at least 10 minutes (keep in normal horizontal position). Make sure the current is flowing, then press **ACK** to calibrate the PV input.
10. If the controller briefly displays SP=20mA PRESS ACK, PV calibration was successful. Move on to step 12.
11. If the controller briefly displays mA CALIB. FAILED, PV calibration was not successful.
Check the 20mA connections, and return to step #3 to recalibrate the PV input.
12. Remove the 20mA input from the PV terminals, and attach it to the SP terminals (see *Figure D.5*).
Make sure the terminal connections are fastened tightly and that a 20mA current is flowing through SP terminals.
13. Let the controller warm up for an additional 5 minutes (keep in the normal horizontal position). Make sure the current is flowing, then press **ACK** to calibrate the SP input.
14. If the controller briefly displays mA CALIB. COMPLETED, SP calibration was successful and the analog milliamp calibration procedure has been completed. If calibration is complete, power down. Place the jumpers into their original positions (see Chapter 4).
15. If the controller briefly displays mA CALIB. FAILED, SP calibration was not successful. Check the 20mA connections, and return to step #3 to recalibrate the PV and SP inputs.

MILLIAMP OUTPUT CALIBRATION

Once a year, calibrate the milliamp output to maintain optimal performance. Additionally, calibrate an output whenever a new milliamp module is installed.

The 531 local output should be calibrated at terminals 5 and 6 (OUT2- and OUT2+). The bypass circuitry need not be removed to perform this calibration.

Equipment needed:

- Precision 5-1/2 digit multimeter, e.g., Fluke 8842® or HP3478A® (4-1/2 digit meters sacrifice accuracy)
- Two small pieces of wire for every milliamp output
- Test leads with clips ends
- #2 Phillips screwdriver

1. Disconnect power to the instrument.
2. Remove chassis from case.

3. On the Microcontroller Circuit Board locate jumper locations marked PV1 and 2nd near the edge connector. Reposition both jumper connectors in the 2nd location onto pins for V and TC▲, as shown in *Figure D.2*
4. Reinsert chassis into the case and apply power.
5. Allow controller to warm up for at least 30 minutes.
The 2nd and 3rd displays should read CALIBRATE ANALOG. IN. (**CALIBRATE Menu, ANALOG. IN section**).
Press **MENU** three times to reach the **CALIBRATE ANLG. OUT** Menu.
6. Connect hook up wires to the terminals for Output 2 (refer to *Figure D.7*).
Attach the test leads from the multimeter to the wires, and then plug the test leads into the meter. Set the meter for DC milliamp.
7. Press **ACK**. The 2nd display will read OUTPUT2.
8. The 3rd display should read 4 mA.
The multimeter should read a value close to 4.00.
9. Wait one minute. Use ▲ and ▼ (and **FAST**) on the controller to change the meter's display to exactly 4.00 mA.
10. Press **MENU**. The 3rd display should read 20 mA.
11. Let this setting stabilize for 5 minutes. Use ▲ and ▼ (and **FAST**) on the controller to change the meter's display to exactly 20mA.
12. To complete calibration, press **ACK** key, disconnect the power and place the jumper connectors back into their original position (refer to Chapter 3).

Figure D.7
Milliamp Calibration Wiring

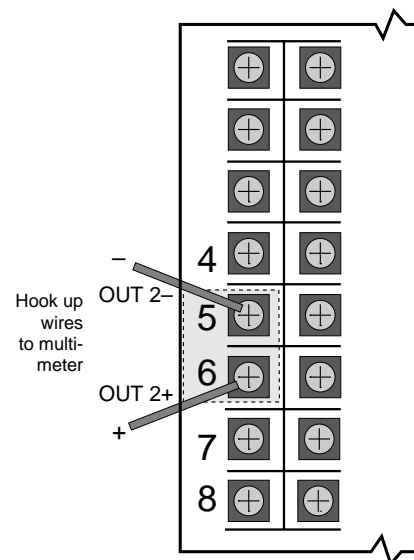

RESET MENU DATA

This function resets all parameter values back to their factory default values (except for calibration information). Refer to the flowchart in *Figure D.1*.

1. Disconnect power to the instrument.
2. Remove chassis from case.
3. On the Microcontroller Circuit Board, set jumpers at the 2nd PV location to **V** and **TC▲**.
4. Press **MENU** key until the display shows RESET MENU DATA.
5. Press the **ACK** key.
6. Press **MENU** key within two seconds to reset the menu data.
If successful, RESET COMPLETED will appear in the display.
If failed, RESET SKIPPED will appear instead.
7. To try again, press **ACK** key, and then press **MENU** key within two seconds.
8. When complete, return jumpers to their original positions.

HARDWARE SCAN

Use this read-only feature to identify the output hardware and installed options of the controller.

1. Set the jumpers to **V** and **TC▲** on the Microcontroller Circuit Board (see *Figure D.2*).
2. Power up the controller
3. Press **MENU** until HARDWARE SCAN is displayed.

4. Press **ACK** to initiate the hardware display.
5. When complete, return jumpers to their original positions (as in Chapter 3).

QUICK CALIBRATION PROCEDURE For mA or V inputs

This procedure is for the benefit of users that have ISO or other standards that require periodic calibration verification. It enables verification and modification of the process variable input without entering the “Factory Configuration” mode.

1. Power down the 531 controller and place the input jumpers in the desired position (refer to Figure D.2 and Figure D.6).
2. Replace the process variable (PV) input signal with a suitable calibration device.
3. Apply power and allow controller to warm up for 30 minutes.
4. Place controller in manual mode. Go to the **PV INPUT** menu, **PV OFFSET** parameter.
5. Adjust the calibration device to an output signal equal to the 0% range value for the particular input sensor (for example, 4mA for a 4-20 mA input).
6. Verify value indicated in the 1st display is equal to the 0% range value for the particular input sensor. If incorrect, use the **▲** and **▼** keys to scroll to the correct value.
7. **For a linear voltage or mA input:** Press **MENU** to scroll to the **PV GAIN** parameter.
For other inputs: go to step #8.
8. Adjust the calibration device to an output signal equal to the 100% range value for the particular sensor.
9. Verify that the value shown in the 1st display is equal to 100% of the range value for the particular input sensor. If the value is not correct, use the **▲** and **▼** keys to scroll to the correct value.
10. Repeat steps 4 through 8 to verify all values.
11. Press **DISPLAY** to return to the Operation mode.

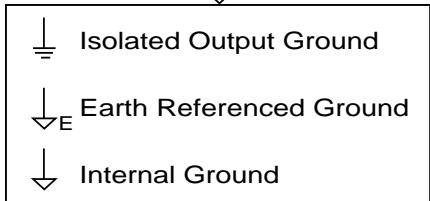
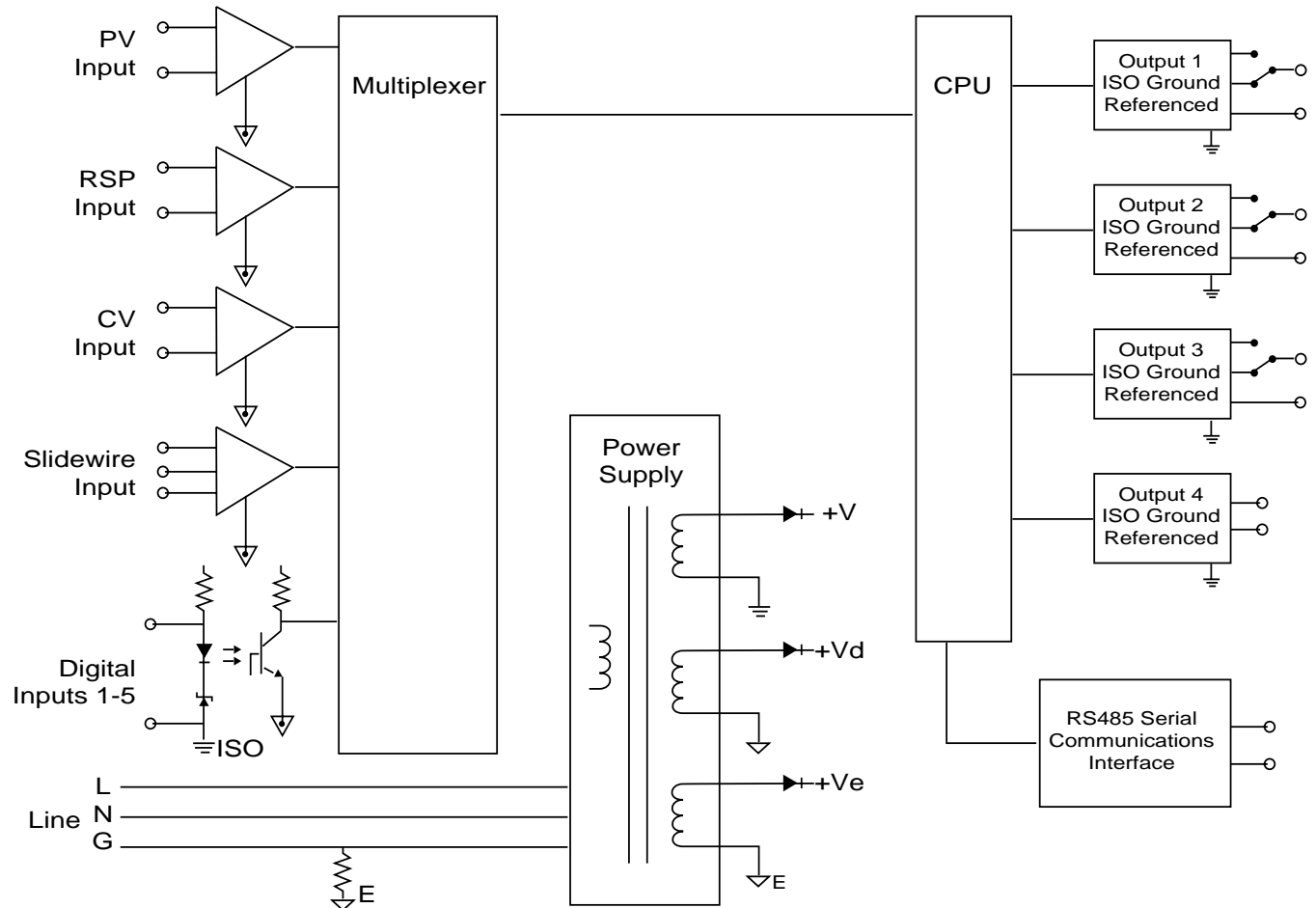

1. Each of the three ground circuits are isolated from each other to withstand a potential of 500 volts for 1 minutes, or 600 volts for 1 second.
2. CV, RSP, Slidewire and the PV & SP inputs are isolated to withstand 50 volts peak between each other for 1 minute.
3. Milliamp, Loop Power and SSR Drive modules in output position 1, 2, 3 and 4 are not isolated from each other.
4. Inputs are not isolated from the analog output due to the failsafe pass-through circuit.

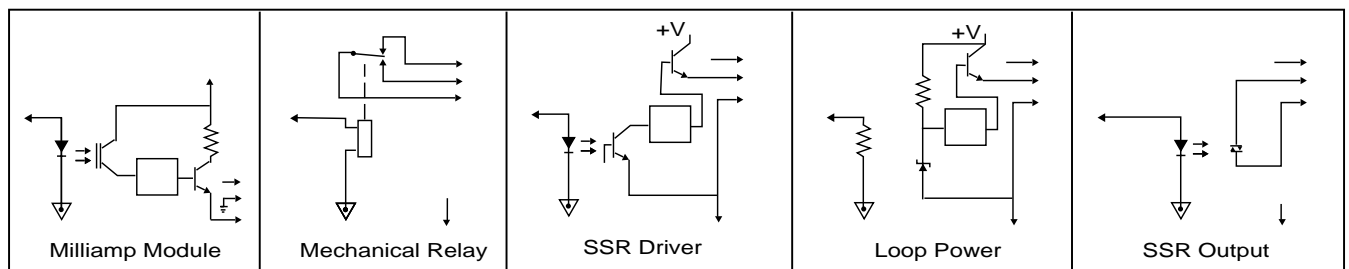

RETURN PROCEDURES

To return equipment to Moore Industries for repair, follow these four steps:

1. Call Moore Industries and request a Returned Material Authorization (RMA) number.

Warranty Repair –

If you are unsure if your unit is still under warranty, we can use the unit's serial number to verify the warranty status for you over the phone. Be sure to include the RMA number on all documentation.

Non-Warranty Repair –

If your unit is out of warranty, be prepared to give us a Purchase Order number when you call. In most cases, we will be able to quote you the repair costs at that time. The repair price you are quoted will be a "Not To Exceed" price, which means that the actual repair costs may be less than the quote. Be sure to include the RMA number on all documentation.

2. Provide us with the following documentation:
 - a) A note listing the symptoms that indicate the unit needs repair
 - b) Complete shipping information for return of the equipment after repair
 - c) The name and phone number of the person to contact if questions arise at the factory
3. Use sufficient packing material and carefully pack the equipment in a sturdy shipping container.
4. Ship the equipment to the Moore Industries location nearest you.

The returned equipment will be inspected and tested at the factory. A Moore Industries representative will contact the person designated on your documentation if more information is needed. The repaired equipment, or its replacement, will be returned to you in accordance with the shipping instructions furnished in your documentation.

WARRANTY DISCLAIMER

THE COMPANY MAKES NO EXPRESS, IMPLIED OR STATUTORY WARRANTIES (INCLUDING ANY WARRANTY OF MERCHANTABILITY OR OF FITNESS FOR A PARTICULAR PURPOSE) WITH RESPECT TO ANY GOODS OR SERVICES SOLD BY THE COMPANY. THE COMPANY DISCLAIMS ALL WARRANTIES ARISING FROM ANY COURSE OF DEALING OR TRADE USAGE, AND ANY BUYER OF GOODS OR SERVICES FROM THE COMPANY ACKNOWLEDGES THAT THERE ARE NO WARRANTIES IMPLIED BY CUSTOM OR USAGE IN THE TRADE OF THE BUYER AND OF THE COMPANY, AND THAT ANY PRIOR DEALINGS OF THE BUYER WITH THE COMPANY DO NOT IMPLY THAT THE COMPANY WARRANTS THE GOODS OR SERVICES IN ANY WAY.

ANY BUYER OF GOODS OR SERVICES FROM THE COMPANY AGREES WITH THE COMPANY THAT THE SOLE AND EXCLUSIVE REMEDIES FOR BREACH OF ANY WARRANTY CONCERNING THE GOODS OR SERVICES SHALL BE FOR THE COMPANY, AT ITS OPTION, TO REPAIR OR REPLACE THE GOODS OR SERVICES OR REFUND THE PURCHASE PRICE. THE COMPANY SHALL IN NO EVENT BE LIABLE FOR ANY CONSEQUENTIAL OR INCIDENTAL DAMAGES EVEN IF THE COMPANY FAILS IN ANY ATTEMPT TO REMEDY DEFECTS IN THE GOODS OR SERVICES. BUT IN SUCH CASE THE BUYER SHALL BE ENTITLED TO NO MORE THAN A REFUND OF ALL MONIES PAID TO THE COMPANY BY THE BUYER FOR PURCHASE OF THE GOODS OR SERVICES.

ANY CAUSE OF ACTION FOR BREACH OF ANY WARRANTY BY THE COMPANY SHALL BE BARRED UNLESS THE COMPANY RECEIVES FROM THE BUYER A WRITTEN NOTICE OF THE ALLEGED DEFECT OR BREACH WITHIN TEN DAYS FROM THE EARLIEST DATE ON WHICH THE BUYER COULD REASONABLY HAVE DISCOVERED THE ALLEGED DEFECT OR BREACH, AND NO ACTION FOR THE BREACH OF ANY WARRANTY SHALL BE COMMENCED BY THE BUYER ANY LATER THAN TWELVE MONTHS FROM THE EARLIEST DATE ON WHICH THE BUYER COULD REASONABLY HAVE DISCOVERED THE ALLEGED DEFECT OR BREACH.

RETURN POLICY

For a period of thirty-six (36) months from the date of shipment, and under normal conditions of use and service, Moore Industries ("The Company") will at its option replace, repair or refund the purchase price for any of its manufactured products found, upon return to the Company (transportation charges prepaid and otherwise in accordance with the return procedures established by The Company), to be defective in material or workmanship. This policy extends to the original Buyer only and not to Buyer's customers or the users of Buyer's products, unless Buyer is an engineering contractor in which case the policy shall extend to Buyer's immediate customer only. This policy shall not apply if the product has been subject to alteration, misuse, accident, neglect or improper application, installation, or operation. THE COMPANY SHALL IN NO EVENT BE LIABLE FOR ANY INCIDENTAL OR CONSEQUENTIAL DAMAGES.



WORLDWIDE • www.miinet.com

United States • info@miinet.com Tel: (818) 894-7111 • FAX: (818) 891-2816	Belgium • info@mooreind.be Tel: 03/448.10.18 • FAX: 03/440.17.97	China • sales@mooreind.sh.cn Tel: 86-21-62491499 • FAX: 86-21-62490635
Australia • sales@mooreind.com.au Tel: (02) 8536-7200 • FAX: (02) 9525-7296	The Netherlands • sales@mooreind.nl Tel: (0)344-617971 • FAX: (0)344-615920	United Kingdom • sales@mooreind.com Tel: 01293 514488 • FAX: 01293 536852

500 SERIES

Process Controllers

Form M500 V6

5 0 0

Hardware Installation and Modification Manual

***for Electronic Products
Series 531, 532,
535, 545, 555
Model 2***



Installation

INTRODUCTION

This technical brochure provides hardware installation and modification instructions for our controllers: **Series 531, 532, 535, 545, and 555. Use these instructions with the following kits:**

Display Assembly Kits

531-632	531 Display Assembly Kit
532-632	532 Display Assembly Kit
535-632	535 Display Assembly Kit
545-634	545 Display Assembly Kit
555-632	555 Display Assembly Kit

Output and Communications Module Kits

532-600	531, 532 Analog Module Kit
535-600*	Mechanical Relay Module Kit
535-601*	Milliamp Module Kit
535-602*	SSR Module Kit
535-603*	SSR Drive Module Kit
535-604*	Loop Power Module Kit
535-705*	RS-485 Communications Module Kit

Power Supply Kit

535-730*	90 to 250VAC Power Supply Kit
535-732	24VAC/VDC Power Supply Kit

Mounting Kit

535-761*	Mounting Kit
----------	--------------

Miscellaneous Kits

532-100	531, 532 Bypass Board Kit
535-188*	Rear Terminal Upgrade Kit
535-660	531, 532, 535, 545, 555 Jumper Kit
535-662*	Gasket Kit (1 Panel Gasket, 1 Bezel Gasket)
535-763*	Bezel Retention Screw Kit
535-664*	Module Retention Kit (Retention Plate and Tie Wrap)
535-665*	Module Retention Tie Wrap Kit
093-128*	Lithium Battery

EPROM Kits

531-740	531 EPROM Kit
532-740	532 EPROM Kit
535-741	535 EPROM Kit (RSP)
535-775	535 Profiler EPROM Kit (No RSP)
535-776	535 Profiler EPROM Kit (RSP)
535-740	535 EPROM Kit (No RSP)
545-740	545 EPROM Kit (No RSP)
545-741	545 EPROM Kit (RSP)
555-740	555 EPROM Kit

Microcontroller (MCU) Board Kits

535-731	MCU Board Kit
545-733	MCU Board Kit with CE Option

Option Board Kits

535-720	531, 532, 535, 545 Option Board Kit (No Options)
535-721	531, 532, 535, 545 Option Board Kit (Digital Inputs)
535-722	535, 545 Option Board Kit (Slidewire Feedback)
535-723	535, 545 Option Board Kit (Digital Inputs and Slidewire Feedback)
545-724	531, 532, 535, 545, 555 Option Board Kit (RSP)
545-725	531, 532, 535, 545, 555 Option Board Kit (Digital Inputs and RSP)
545-726	535, 545, 555 Option Board Kit (Slidewire Feedback and RSP)
545-727	535, 545, 555 Option Board Kit (Digital Inputs, Slidewire Feedback, and RSP)

* **Universal Kit (can be used with all 500 Series Controllers)**

HOW TO USE THIS MANUAL:

- CAUTION: Static discharge will cause damage to equipment. Always ground yourself with a wrist grounding strap when handling electronics to prevent static discharge.**
- Before removing or inserting any hardware on the controller, **copy down all configuration parameters**. Also, **replacing the battery, EPROM or MCU Board will erase parameter settings** and they will need to be reset.
- For all hardware adjustments, **perform steps 1, 2 and 3**.
- Follow the guide and complete any additional steps as required by your particular application.
- Complete** your hardware adjustments with **steps 15, 16, 17, 18, 19 & 20**.

EQUIPMENT

To make any hardware changes to the units, you will need the following equipment:

- Wrist grounding strap
- Small flat blade screwdriver
- I.C. Extractor (if changing the EPROM)
- Phillips screwdriver (#2)
- Wire cutters

INSTRUCTIONS

To Disassemble the Unit

For any hardware modifications, disassemble the unit.

1. With power off, loosen four captive front screws with a Phillips screwdriver. Remove the four screws.

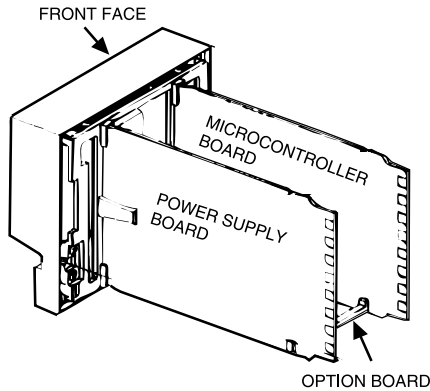

Figure 1
Location of Printed Circuit Boards for Hardware Configuration

2. Slide the chassis out of the case by pulling on front face plate assembly at the bezel (see **Figure 1**).

3. Locate the retention clips holding the front face assembly to the rest of the chassis. Pry apart these retention clips gently with a screwdriver to separate the printed circuit board group from the front face assembly (Photo 3). Take care not to break the clips or scratch the circuit board.

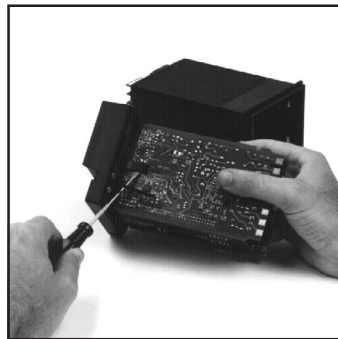

Photo 3. Pry Clips

The Microcontroller Board and Power Supply Board remain attached to the Operator Interface Assembly by wired connectors.

4. The Microcontroller and Power Supply board are attached to either side of the Option board by male/female pin connectors. Use a gentle rocking motion and carefully apply pressure in a uniform direction to separate

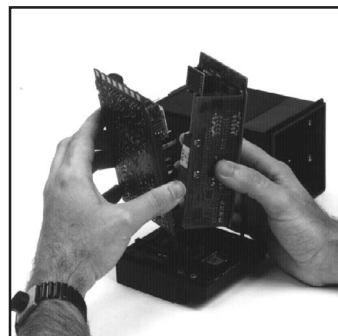

Photo 4. Separate Boards

one of the larger two boards from the Option Board (Photo 4). Be careful not to bend the connector pins. Separate the other board in the same manner.

Figure 2 (opposite page) shows the Microcontroller Board, Option Board and Power Supply Board.

To Add or Change Output Modules

The 500 Series units have provisions for four output modules. The units come factory configured with specified modules installed in appropriate locations. You can make field modifications by properly removing and/or adding the modules into the appropriate sockets.

Three of the output sockets are located on the Power Supply Circuit Board. A fourth output socket is located on the Option Board (refer to **Figure 2**).

5. A retention plate and tie wrap hold Output modules 1, 2, and 3 (on the Power Supply board) firmly in place. To remove the retention plate, snip the tie wrap with wire cutters (Photo 5).

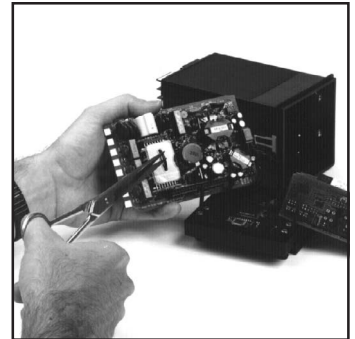

Photo 5.

Remove Retention Plate

CAUTION: Always snip the tie wrap on top of the Retention Plate, as shown in photo 5, to prevent damage to the surface mount components.

6. A disposable tie wrap holds Output module 4 (on the Option board) in place. To remove the module, snip the tie wrap (Photo 6).

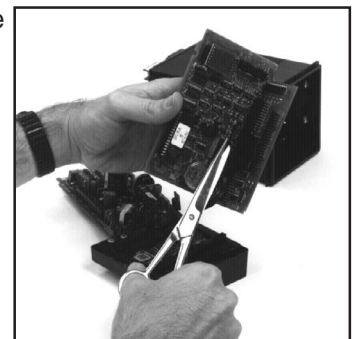
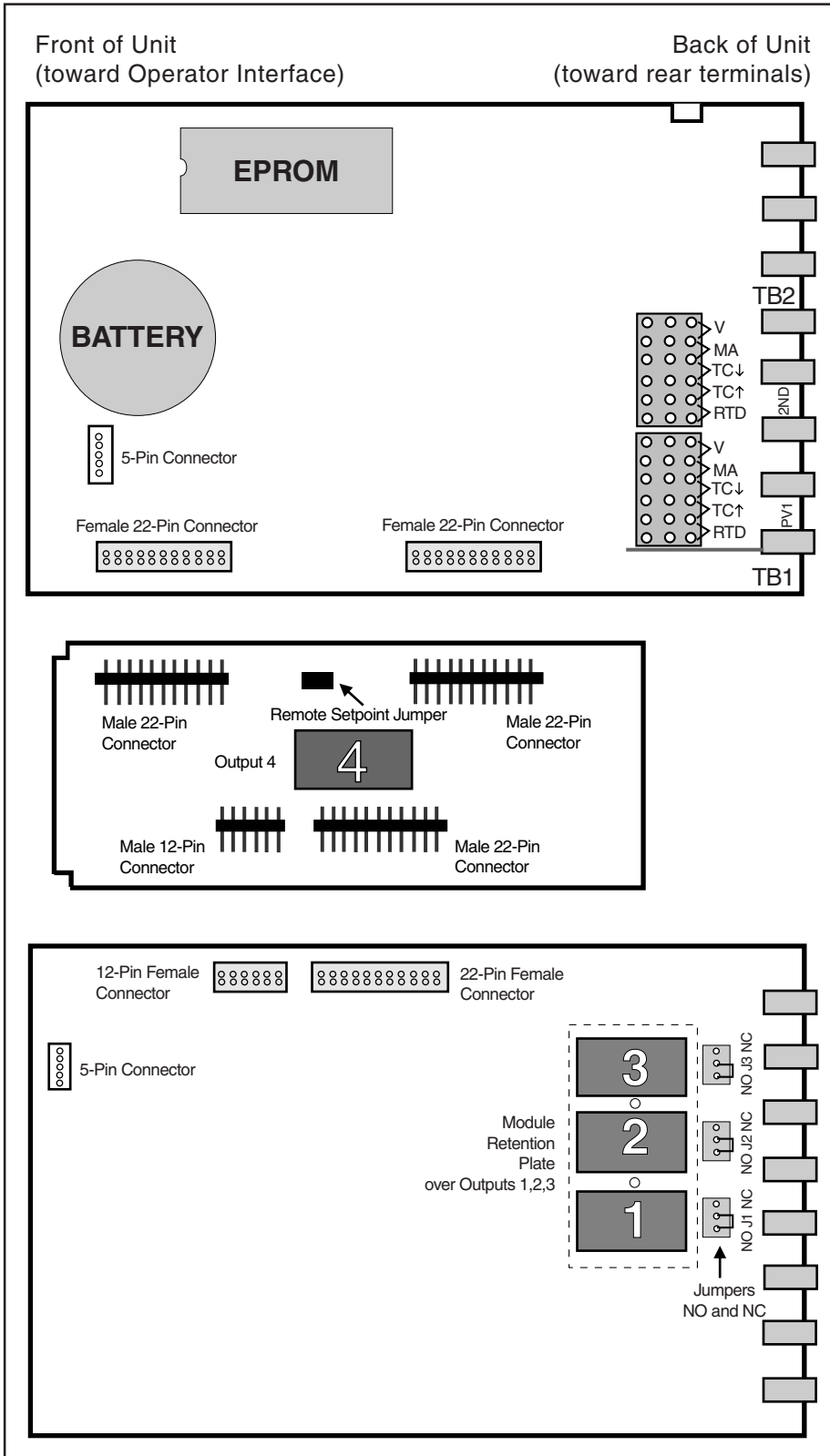

Photo 6.

Snip Tie Wrap on Mod. 4

7. Inspect each module before installation to make sure the pins are straight. Align the pins with the socket holes and carefully insert the module. Press down on the module to seat it firmly on the board.

Installation



NOTE:

If you replace the EPROM chip, you must align the notch facing the front of the unit.

NOTE:

The 5- and 22-Pin connectors on the boards are all keyed so they will only align one correct way.

Figure 2
Microcontroller Board,
Option Board,
and Power Supply Board

8. Replace tie wraps for the Retention Plate and for Output Module 4 with new ones.

Failure to use these devices may result in a loosening of the module and eventual failure. If you ordered a module separately, it should have come with a tie wrap. An extra set of tie wraps is available by ordering Part #535-665.

Note: For greatest accuracy, milliamp modules added for retransmission must be calibrated per instructions in Operator's Manual.

To Change the Option Board

9. (See Photos 3 and 4) Replace the existing Option board with the NEW one.

Note: When adding Option board for 5 digital inputs, associated screw terminal in the rear terminal block must be installed. (See information on page 1 for ordering a Screw Kit.)

To Change the Power Supply or Microcontroller (CPU) Board

10. For the Microcontroller Board, disconnect the 5-pin female connector that wires it to the Display Assembly. Reattach the connector to the new board. You can only orient the connector one way.
For the Power Supply Board, disconnect the 5-pin female connector that wires it to the Display Assembly. Reattach the connector to the new board. You can only orient the connector one way.

To Change the Display Assembly

11. Disconnect the 5-pin female connector that wires the Microcontroller Board to the Display Assembly. Disconnect the 5-pin female connector that wires the Power Supply Board to the Display Assembly.
12. Attach the new Display Assembly to the boards at the appropriate connectors.

CAUTION

Static discharge will cause damage to equipment. Always ground yourself with a wrist grounding strap when handling electronics to prevent static discharge.

CAUTION

Do not scratch the boards or bend the pins of the connectors.

To Change the EPROM

13. The EPROM is located on the Microcontroller Circuit board (**Figure 2**). It has a white label that list the part number and software revision level. Use an I.C. Extractor to carefully remove the EPROM. If you do not have an I.C. extractor, gently use a small flat blade screwdriver to pry up the EPROM. DO NOT bend the EPROM legs.
14. Carefully insert the new EPROM. To position correctly, match the notched end of the EPROM to the markings on the board. The notched end will face towards the display. Make sure all pins are in the socket.

To Reassemble the Unit

15. (See **Figure 2**) Align the connector pins on the Option Board with the connector sockets on the Microcontroller and Power Supply boards. Squeeze them together, making certain all three are properly seated against one another. Check along the side edges for gaps. Make sure the connector is properly aligned. Also, check that the cable assemblies are not pinched.
16. (See **Figure 2**) Align the board assembly with the front face assembly, with the Option board at the bottom (see **Figure 1**). Reinstall the retention clips. Align the boards into the slots of the front face assembly and the clips will snap into place.
17. When you are ready to reassemble the unit, align the boards in the chassis with the case's top and bottom grooves. Press firmly to slide the chassis into the case. If you have difficulty, check that you have properly oriented the chassis, and there are no screws interfering with the case.
18. Carefully insert and align screws. Tighten them until the bezel is seated firmly against the gasket. DO NOT OVERTIGHTEN.
19. If may be necessary to re-configure the software features of your controller or station. Please refer to your User's Manual.
20. To maintain NEMA 4X Rating, you may need new mounting gaskets, order part #535-662. Refer to your user's manual.



Declaration of Conformity

EMC Directive 89/336/EEC



Manufacturer's Name: Moore Industries-International, Inc.
Manufacturer's Address: 16650 Schoenborn Street
 North Hills, CA 91343-6196
 USA

Declares that the product(s):

Product Name: 500 Series

MODEL	INPUT	OUTPUT	POWER	OPTIONS	HOUSING
-------	-------	--------	-------	---------	---------

Model Number(s): 500 Series	*	*	24 Vdc	** H or J	*
-----------------------------	---	---	--------	-----------	---

*Indicates any input, output, option and housing as stated on the product data sheet.
 **Indicates CE Compliant.

Conforms to the following EMC specifications:

EN61326-1, 1998, Electromagnetic Compatibility requirements for electrical equipment for control use.

Conforms to the following safety standard:

EN 61010-1, 2001

Supplemental Information:

CE option requires CE KIT PN 535-766.

January 9, 2003

 Date

Fred Adt
 Quality Assurance Director

Robert Stockham
 Moore Industries-International, Inc.

European Contact: Your Local Moore Industries Sales and Service Office

The Interface Solution Experts • www.miinet.com



United States • info@miinet.com
 Tel: (818) 894-7111 • FAX: (818) 891-2816
 Australia • sales@mooreind.com.au
 Tel: (02) 8536-7200 • FAX: (02) 9525-7296

Belgium • info@mooreind.be
 Tel: 03/448.10.18 • FAX: 03/440.17.97
 The Netherlands • sales@mooreind.nl
 Tel: (0)344-617971 • FAX: (0)344-615920

China • sales@mooreind.sh.cn
 Tel: 86-21-62481120 • FAX: 86-21-62490635
 United Kingdom • sales@mooreind.com
 Tel: 01293 514488 • FAX: 01293 536852



Declaration of Conformity

EMC Directive 89/336/EEC



Manufacturer's Name: Moore Industries-International, Inc.
Manufacturer's Address: 16650 Schoenborn Street
 North Hills, CA 91343-6196
 USA

Declares that the product(s):

Product Name: 500 Series

MODEL	INPUT	OUTPUT	POWER	OPTIONS	HOUSING
-------	-------	--------	-------	---------	---------

Model Number(s): 500 Series	*	*	Universal Power Supply	** H or J	*
-----------------------------	---	---	------------------------	-----------	---

*Indicates any input, output, option and housing as stated on the product data sheet.
 **Indicates CE Compliant.

Conforms to the following EMC specifications:

EN61326-1, 1998, Electromagnetic Compatibility requirements for electrical equipment for control use.

Conforms to the following safety standard:

EN 61010-1, 2001

Supplemental Information:

CE option requires CE KIT PN 535-765.

August 15, 2005

Date

Fred Adt

Quality Assurance Director

Robert Stockham

Moore Industries-International, Inc.

European Contact: Your Local Moore Industries Sales and Service Office



The Interface Solution Experts • www.miinet.com

United States • info@miinet.com
 Tel: (818) 894-7111 • FAX: (818) 891-2816
 Australia • sales@mooreind.com.au
 Tel: (02) 8536-7200 • FAX: (02) 9525-7296

Belgium • info@mooreind.be
 Tel: 03/448.10.18 • FAX: 03/440.17.97
 The Netherlands • sales@mooreind.nl
 Tel: (0)344-617971 • FAX: (0)344-615920

China • sales@mooreind.sh.cn
 Tel: 86-21-62481120 • FAX: 86-21-62490635
 United Kingdom • sales@mooreind.com
 Tel: 01293 514488 • FAX: 01293 536852

RETURN PROCEDURES

To return equipment to Moore Industries for repair, follow these four steps:

1. Call Moore Industries and request a Returned Material Authorization (RMA) number.

Warranty Repair –

If you are unsure if your unit is still under warranty, we can use the unit's serial number to verify the warranty status for you over the phone. Be sure to include the RMA number on all documentation.

Non-Warranty Repair –

If your unit is out of warranty, be prepared to give us a Purchase Order number when you call. In most cases, we will be able to quote you the repair costs at that time. The repair price you are quoted will be a "Not To Exceed" price, which means that the actual repair costs may be less than the quote. Be sure to include the RMA number on all documentation.

2. Provide us with the following documentation:
 - a) A note listing the symptoms that indicate the unit needs repair
 - b) Complete shipping information for return of the equipment after repair
 - c) The name and phone number of the person to contact if questions arise at the factory
3. Use sufficient packing material and carefully pack the equipment in a sturdy shipping container.
4. Ship the equipment to the Moore Industries location nearest you.

The returned equipment will be inspected and tested at the factory. A Moore Industries representative will contact the person designated on your documentation if more information is needed. The repaired equipment, or its replacement, will be returned to you in accordance with the shipping instructions furnished in your documentation.

WARRANTY DISCLAIMER

THE COMPANY MAKES NO EXPRESS, IMPLIED OR STATUTORY WARRANTIES (INCLUDING ANY WARRANTY OF MERCHANTABILITY OR OF FITNESS FOR A PARTICULAR PURPOSE) WITH RESPECT TO ANY GOODS OR SERVICES SOLD BY THE COMPANY. THE COMPANY DISCLAIMS ALL WARRANTIES ARISING FROM ANY COURSE OF DEALING OR TRADE USAGE, AND ANY BUYER OF GOODS OR SERVICES FROM THE COMPANY ACKNOWLEDGES THAT THERE ARE NO WARRANTIES IMPLIED BY CUSTOM OR USAGE IN THE TRADE OF THE BUYER AND OF THE COMPANY, AND THAT ANY PRIOR DEALINGS OF THE BUYER WITH THE COMPANY DO NOT IMPLY THAT THE COMPANY WARRANTS THE GOODS OR SERVICES IN ANY WAY.

ANY BUYER OF GOODS OR SERVICES FROM THE COMPANY AGREES WITH THE COMPANY THAT THE SOLE AND EXCLUSIVE REMEDIES FOR BREACH OF ANY WARRANTY CONCERNING THE GOODS OR SERVICES SHALL BE FOR THE COMPANY, AT ITS OPTION, TO REPAIR OR REPLACE THE GOODS OR SERVICES OR REFUND THE PURCHASE PRICE. THE COMPANY SHALL IN NO EVENT BE LIABLE FOR ANY CONSEQUENTIAL OR INCIDENTAL DAMAGES EVEN IF THE COMPANY FAILS IN ANY ATTEMPT TO REMEDY DEFECTS IN THE GOODS OR SERVICES, BUT IN SUCH CASE THE BUYER SHALL BE ENTITLED TO NO MORE THAN A REFUND OF ALL MONIES PAID TO THE COMPANY BY THE BUYER FOR PURCHASE OF THE GOODS OR SERVICES.

ANY CAUSE OF ACTION FOR BREACH OF ANY WARRANTY BY THE COMPANY SHALL BE BARRED UNLESS THE COMPANY RECEIVES FROM THE BUYER A WRITTEN NOTICE OF THE ALLEGED DEFECT OR BREACH WITHIN TEN DAYS FROM THE EARLIEST DATE ON WHICH THE BUYER COULD REASONABLY HAVE DISCOVERED THE ALLEGED DEFECT OR BREACH, AND NO ACTION FOR THE BREACH OF ANY WARRANTY SHALL BE COMMENCED BY THE BUYER ANY LATER THAN TWELVE MONTHS FROM THE EARLIEST DATE ON WHICH THE BUYER COULD REASONABLY HAVE DISCOVERED THE ALLEGED DEFECT OR BREACH.

RETURN POLICY

For a period of thirty-six (36) months from the date of shipment, and under normal conditions of use and service, Moore Industries ("The Company") will at its option replace, repair or refund the purchase price for any of its manufactured products found, upon return to the Company (transportation charges prepaid and otherwise in accordance with the return procedures established by The Company), to be defective in material or workmanship. This policy extends to the original Buyer only and not to Buyer's customers or the users of Buyer's products, unless Buyer is an engineering contractor in which case the policy shall extend to Buyer's immediate customer only. This policy shall not apply if the product has been subject to alteration, misuse, accident, neglect or improper application, installation, or operation. THE COMPANY SHALL IN NO EVENT BE LIABLE FOR ANY INCIDENTAL OR CONSEQUENTIAL DAMAGES.



WORLDWIDE • www.miinet.com

United States • info@miinet.com
Tel: (818) 894-7111 • FAX: (818) 891-2816

Australia • sales@mooreind.com.au
Tel: (02) 8536-7200 • FAX: (02) 9525-7296

Belgium • info@mooreind.be
Tel: 03/448.10.18 • FAX: 03/440.17.97

The Netherlands • sales@mooreind.nl
Tel: (0)344-617971 • FAX: (0)344-615920

China • sales@mooreind.sh.cn
Tel: 86-21-62491499 • FAX: 86-21-62490635

United Kingdom • sales@mooreind.com
Tel: 01293 514488 • FAX: 01293 536852