



User Manual

Excel *Entice 4*

Read instructions before use

'Smart mobility solutions'

Welcome aboard your new **Entice** scooter!

We wish to thank you for letting us improve your freedom and independence. This model has been designed with your practical needs in mind. It is equipped with modern high tech electronics and special features for a more comfortable ride. Its safety and performance will provide you with years of excellent service and pleasure!

It is from the utmost importance to read this manual very well before using the Excel **Entice** scooter. The manual contains important information concerning the use and small maintenance of the **Entice**.

Safe use of the **Entice** is a following issue. This manual should be stored very well. It contains information that might come in handy later!

The italic printed parts in this manual are from extra importance. They supply important information concerning safe use of you mobility scooter.

The intended use of the Excel **Entice** is for people of all ages, who have trouble with walking far distances or walking for a longer time.

The **Entice** is an outdoor use scooter. The seat can be adjusted by the user. The seat height can also be adjusted to lower leg length. The seat is able to turn and the flip backward armrests can be used for an easy transfer. The maximum speed of the **Entice** is about 15 km/h and at a normal daily use the range is up to 50 km (in combination with 73Ah batteries). The **Entice** can be loaded up to about 220 kg. The electric engine is controlled by a control unit with micro processor. The electronic driving characteristics can be adjusted to your wishes within certain limits. Please contact your dealer in this case.

ATTENTION! INDIVIDUAL ADJUSTMENTS TO THIS PRODUCT NEED TO BE DONE WITH THE MANUFACTURERS WRITTEN APPROVAL.

Your mobility scooter is a vehicle developed according to the European guideline EN12184, and is designed and intended for people to compensate a handicap or mobility problem.

This mobility scooter is especially designed for use by handicapped people or people with a mobility problem and can be used as such.

When insuring this scooter, you need to bring this manual to the insurance company and hand over a copy of the CEdeclaration as printed in this manual on page 15.

Contents

Introduction	1
General safety precautions	2
Driving inclines	2
Transport	3
Freewheel mode	3
Electric Magnetic Compatibility	3
Seat fixation belt	4
Liability	4
First use	4
Learning the scooter	5
Controls	10
Control lever (throttle lever)	10
Battery indicator	10
Alarm light	11
Indicators	11
Horn	11
Speed adjustment	11
Status indicator	11
Charging plug	12
Making a transfer	12
Driving	12
Driving inclines	13
Obstacles and thresholds	13
Brakes	14
Battery safety	14
Freewheel lever	14
Seat of the Entice	15
Backrest angle adjustment	15
Adjust armrests	16
Adjust head rest (option)	16
Removal of seat	16
Adjust tiller	16
Manually moving the Entice	17
Fault by engaged freewheel	17
Charging the batteries	17
Charger specifications	18
Opening battery space	19
Storage	19
Upholstery	19
Frame- and plastic parts	19
Tires	19
Other maintenance	19
Replacement parts	20
Maintenance frequency	20
Faults	21
Range	21
Standard programmed driving parameters	22
Warranty conditions	22
CE-conformity declaration	23

General safety precautions

The **Entice** is designed to be safe in use. This can be noticed on the scooter directly in the below features:

- When charging the scooter it cannot be driven electrically
- At too high engine and controller unit (Dynamic Rhino) the **Entice** will drive at half power
- With the freewheel function engaged the scooter cannot be driven electrically
- If the control lever is in neutral position the scooter cannot be driven.
- Scooter parts where might be body parts clamped between are fully covered

*The **Entice** is meant to be used by one person. Placing a second person on the scooter is not allowed. The driving characteristics will be influenced badly by this and the **Entice** will damage.*

Inside the control unit (Dynamic Rhino) is a function build who prevents deep de-charge of the batteries. The control unit reduces the speed eminently.

*Please make sure when driving the scooter and performing small maintenance to the **Entice** there can be no fingers injured in the space between the covers and the wheels.*

Driving inclines

A very safe control feature when driving inclines is the following: if the **Entice** is able to drive an incline, the incline can also be descent with reduced speed. Always drive a steep incline up first and make sure the **Entice** is not too heavily loaded.

*Turning the **Entice** on an incline is not recommended. The scooter can easily tip over.*

Never drive from a pavement or incline diagonal. The scooter may tip over. Always drive off a pavement or incline at low speed.

In areas with pedestrians it is recommended to adjust the maximum speed to a lower standard for your and other persons safety.

Transport

Transporting the **Entice** inside a vehicle can be done by making the scooter as small as possible. In this case, you dismount the chair and fold the tiller down. Always check if the scooter is not in freewheel mode and fixate it firmly to the floor.

It is recommended to not sit in the scooter during transport. The scooter should always be lifted by two persons, one at the front (front bumper) and one at the back of the scooter (rear bumper). Van Os Medical accepts no responsibility for any eventual consequences.

Freewheel mode

On freewheel engagement the brakes of the **Entice** are not working. By disengaging the freewheel lever the brakes will be in work again. Look at page 17 for further freewheel explanation.

Never use the freewheel mode when standing on an incline. This may cause the scooter drive by itself.

Electro Magnetic Compatibility

A couple of European standards have been set in the field of electro magnetic interference on electric devices. The **Entice** complies to these demands. In an extreme case the **Entice** might be sensitive to very powerful transmitters. This may cause unexplainable faults. In this case you best turn to your dealer.

*When using transmitters nearby the **Entice** , we recommend to first shut down the scooter before using a device. Examples of transmitters can be mobile phones, walkie talkies or a 27 MC transmitter. The **Entice** itself also transmits electric waves. These are within the applying standards. There might be, however, certain unintended events, like a shop alarm going off.*

Fixation belt (optional)

An optional fixation belt can be mounted to fix the seat position (picture 1). The two parts of the belt can be mounted below the seat with screws. The screws fixate the belt to the ground plate of the seat. By use of a click buckle the belt can be fixated.

Picture 1

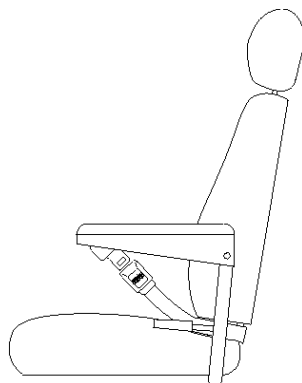

The fixation belt can only be used on the chair. During transport in a wheelchair taxi the fixation belt may not be used as a safety belt.

Liability

Van Os Medical B.V. can not be held responsible for unsafe situations, accidents or damages, as a result from:

- use for other purposes or under other circumstances than indicated in this manual. This also contains applying other than the original replacement parts and changing the programming adjustments of the Rhino controller
- ignoring warnings or precautions noted in this manual
- improper or insufficient maintenance

First use

Not following these safety guidelines may result in damage to the scooter or personal injury

Find an open area such as a park and make sure you have an assistant to help you exercise with the scooter (picture 2).

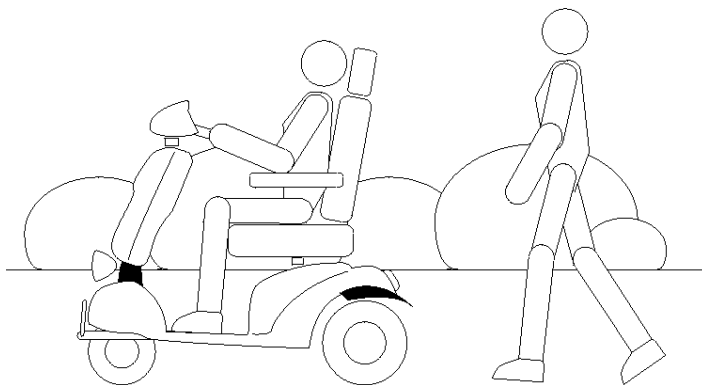

Picture 2

Make sure the scooter is off before getting in or out of it. Set the speed control knob according to your driving ability. We recommend that you keep the speed at the slowest position (fully counter-clockwise) until you are familiar with the driving characteristics of this vehicle.

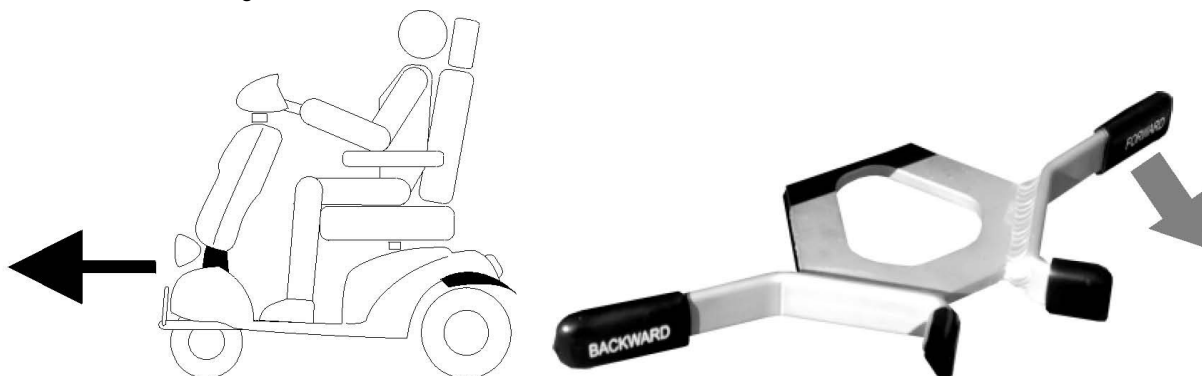

Picture 3

Learning the scooter

Now, practice moving forward by pulling the right lever. Be sure to set the speed to the lowest setting (1).

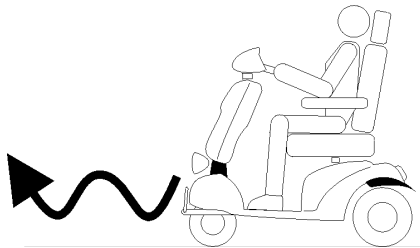

Picture 4

After becoming familiar with moving forward, practice making 'S' turns (picture 4).

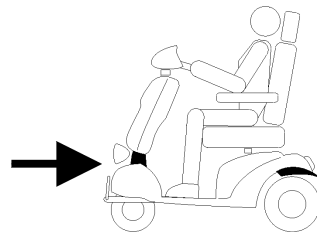

Picture 5

Once you are familiar with 'S' turns, practice moving in reverse. When driving backward the scooter already drives slower than forward, but for your safety we recommend to put the setting to the lowest level (1).



Pay attention to the following warnings:



Picture 6

Do not carry any passengers (picture 6)!



Picture 7

Do not drive across a slope (picture 7)



Picture 8

Never drink and drive (picture 8)!



Picture 9

Do not tow a trailer (picture 9)

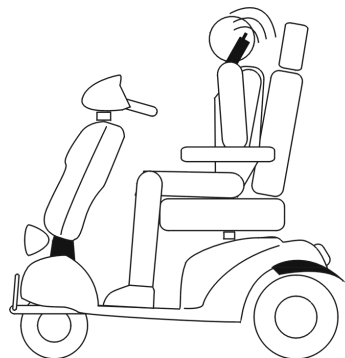

Picture 10

Do not turn on or use hand-held personal communications devices such as citizens band (CB) radios and cellular phones.

When driving on the road, pay attention to the following:

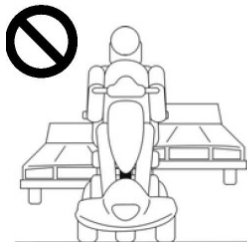

Picture 11

Do not drive in heavy traffic (picture 11)



Picture 12

Do not drive beside a river, port or lake without a fence or railing (picture 12)



Picture 13

Do not drive during rain (Picture 13)



Picture 14

Do not drive during or in snow (Picture 14)



Picture 15

Do not drive off-road or on any uneven surfaced roads (picture 15)



Picture 16

Be sure to use headlights when driving at night (picture 16)

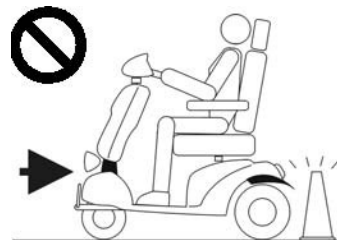

Picture 17

Make sure that there are no obstacles behind you when driving in reverse
We recommend to set the speed knob at the lowest speed (1) when driving backwards (picture 17)

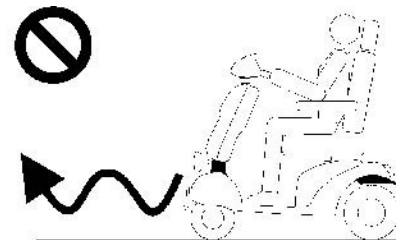

Picture 18

Do not make sudden stops, weave erratically, or make sharp turns (picture 18)



Picture 19

Keep your hands on or in range of the armrests and feet on the footplate (picture 19)

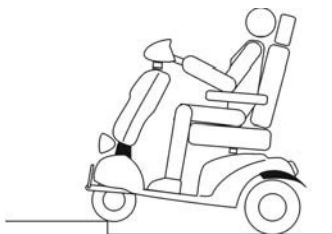

Picture 20

Do not attempt to climb curbs greater than 5 cm (picture 20)



Picture 21

Do not attempt to cross over a gap greater than 10 cm (picture 21)



Picture 22

Do not attempt to climb a hill greater than 10° (picture 22)

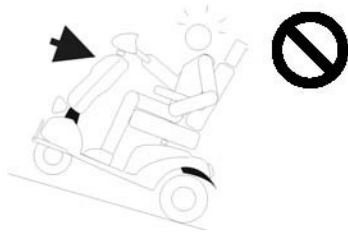

Picture 23

Do not reverse while driving up a hill. If you reverse while driving uphill, it may cause the vehicle to tip over (picture 23)



Picture 24

Use caution when driving over soft, uneven or unprotected surfaces such as grass, gravel and slippery decks (picture 24)



Picture 25

Use low speed while driving downhill. When going downhill, the tiller will become harder to reach and handle. When braking while moving downhill the scooter will take longer to come to a complete stop (picture 25)



Picture 26

Do not make a transfer on an incline. Always stop on the level surface to get in and out of the vehicle (picture 26)



Picture 27

Always climb or descend gradient (picture 27)



Picture 28

Do not load or carry heavy items in perpendicular to the slope or ramp the basket while driving downhill (picture 28)

Control units

The control units of the **Entice** are very clearly arranged on the dashboard (picture 29). The charging plug is located on the tiller, the freewheel lever on the rear right side of the scooter. The status indicator is located on the dashboard. See the below picture for a survey of all control units.

Picture 29

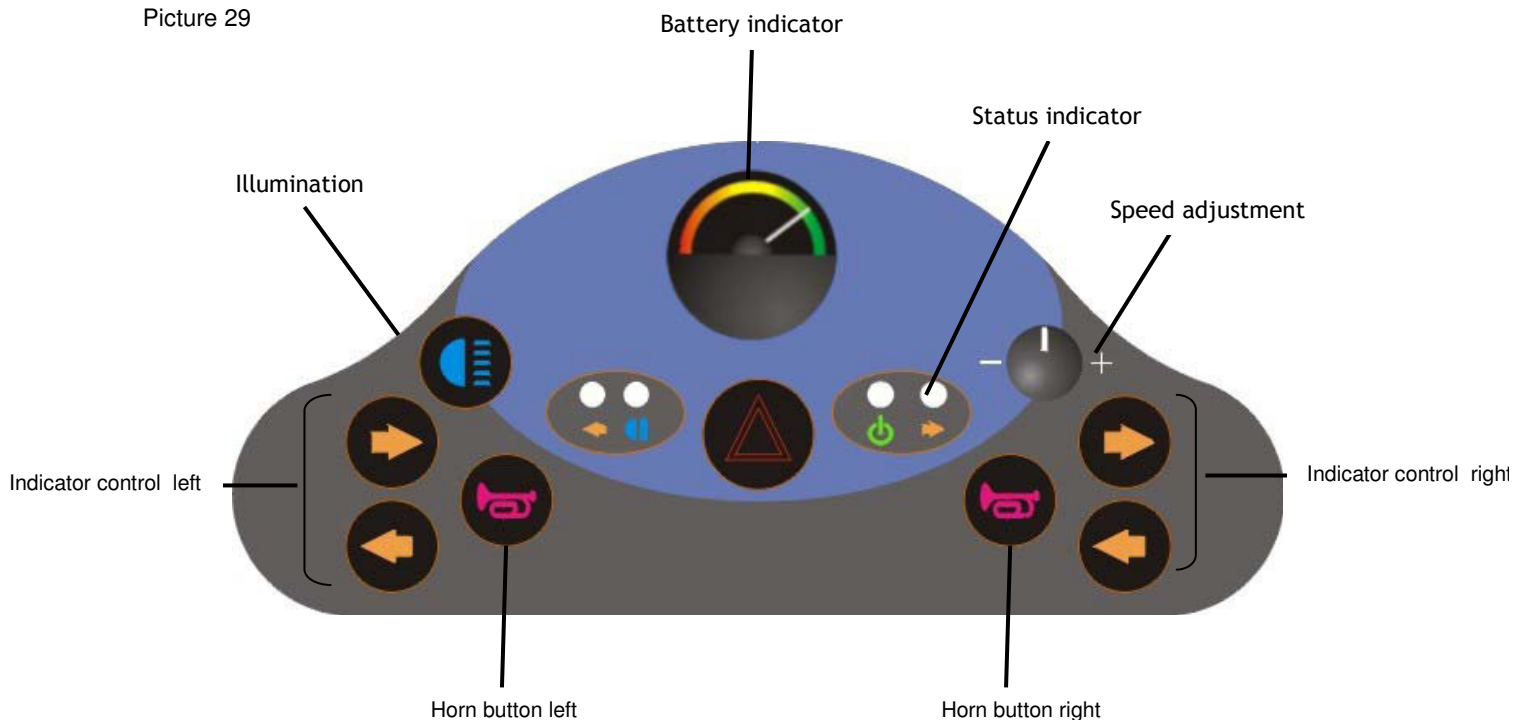

The control lever (throttle lever, picture 30)

Pull the left lever to drive backward.



Pull the right lever to drive forward.

Picture 30

Battery indicator

This indicates the battery charging amount (picture 31). This also affects the range at the time. The indication is divided as below:



Full range
(90% - 100% capacity available)



Decreasing range
(60-70% capacity available)

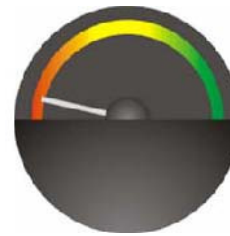

Limited range
(20-30% capacity available)

Picture 31

Warning lights



Warning lights can be powered by pushing the button. By pressing it again, the warning lights will go off.

Horn



Pressing the button sounds the horn.

Status indicator



When scooter is powered and no technical problems are at hand, the Indicator will lit up. If a specific part of the electronics need maintenance or attention the indicator will blink a certain amount of times. See the reference list below for the different code meanings.

Indicators



The switches can be pushed to engage the indicators. They can be operated both left and right handed.

Speed adjustment



This knob adjusts desired maximum speed. You turn the knob right for a higher maximum speed and left for a lower. Speed can be adjusted in 6 steps.

Number of blinks	Fault	Scooter condition	Remarks
1	Charge battery	Driving possible	Battery voltage lowered to less than 23.3 V, charge batteries soon
2	Battery voltage too low	Driving not possible	Battery voltage lowered to less than 16.5 V, charge batteries immediately
3	Battery voltage too low	Driving not possible	Battery voltage increased higher than 32 V. Probably defect charger.
4	Current limit time out	Driving not possible	Detector detected shortcut in the motor. Warn dealer.
5	Brake fault	Driving not possible	Check if freewheel is connected
6	Gas pot not in neutral at power up	Driving not possible	Contact dealer
7	Speed pot error	Driving not possible	Contact dealer
8	Motor volts error	Driving not possible	Contact dealer
9	Other internal error	Driving not possible	Contact dealer
10	Push too fast fault	Driving not possible	Turn off the scooter and restart

Charging plug

To charge the batteries use a charger which guards the process and is convenient to charge the fitted batteries. Your battery charger should be equipped with a 3-pole plug which fits into the charging plug in the tiller.

Making a transfer

Make sure the **Entice** is always turned off and in freewheel position before making a transfer.

- move the rotation lever upwards to unlock the chair (picture 32)
- next, turn the chair 90° left or right. The chair will automatically lock on every 45° if you release the rotation lever (picture 32)

take place on the chair and turn it back to the starting position. The chair is fitted with flip-backward armrests. These can be flipped away to be able to make an easy side transfer. Always make sure to flip the armrests back in the original position when seated.



Picture 32

The Entice can be powered up with the ignition key on the right side of the tiller. After a brief self-test the **Entice** is ready to drive. By pulling the right side of the gas lever (at thumb control pushing), the **Entice** moves forward. The closer you pull the lever towards you, the faster the scooter will drive. If you release the lever the **Entice** will stop. For reversing please stop the scooter first. Now pull the left side of the gas lever (a thumb control push). The **Entice** now will drive backwards, with reduced speed.

- Before you drive, first check if the chair is properly fixated.
- Make sure the tires are always on the right pressure (see technical specifications).
- Make sure the batteries are always sufficiently charged. The pointer of the battery indicator should be in the green area.

- Should the gas lever not be in neutral position when the **Entice** is powered up, it will not drive. Only after the control lever has been placed in neutral position, the **Entice** is ready to drive. The neutral position is when the gas lever is not operated.
- Never take sharp turns while driving at full speed. We recommend to slow down before making a sharp turn. We strongly recommend to avoid dangerous driving in corners.
- Always think of your own safety if you drive from the even road with the **Entice**. Adjust your speed. Never drive through deep holes, water etc.
- The ideal stability and weight balance can be achieved when taking the following points into consideration: always sit straight on the chair and place your feet as far to the front as possible. Do not lean left or right while driving.

Driving on an incline

A very safe control feature when driving inclines is the following: if the **Entice** is able to drive an incline, the incline can also be descent with reduced speed. Always drive a steep incline up first and make sure the **Entice** is not too heavily loaded.

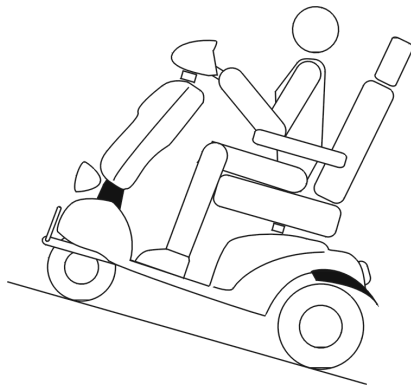

Picture 33

Driving up a hill: lean a little forward and drive as constant as possible in a straight line up (picture 33). To stop and restart driving costs extra energy.

Driving off a hill: lean a little backward and drive carefully with low speed down the hill.

A will which is difficult to climb for the **Entice** needs to be avoided. When climbing very steep inclines (over 12°) is dangerous. At sudden braking the scooter might tip over to the front or the back.

Obstacles and thresholds

Driving obstacles should be done very carefully. When driving an obstacle which is too high the **Entice** might get stuck. For maximum ground clearance please see the chapter 'Technical data'.

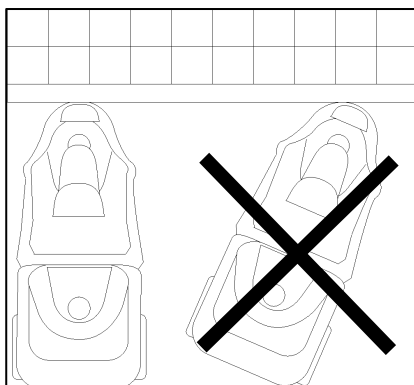

Picture 34

Driving up thresholds: drive towards the threshold until the front wheel is approximately 20-50 cm before the threshold. Now carefully drive forward and approach the threshold. As soon as the front wheel is on the threshold you can slowly drive further until the rear wheels are also on or over the threshold (picture 34). If this does not succeed or very difficult, please choose another route.

Driving off thresholds: drive to the threshold until the front wheel is before it. Drive off the threshold carefully and with low speed. Please always make sure that the anti-tip device never interferes with a threshold or kerb when mounting or dismounting.

Brakes

Braking can be done in different ways:

- you can slowly move the gas lever into the neutral position, to make the **Entice** slow down easily
- you can just let the gas lever go, so the **Entice** will come to a full stop
- the **Entice** is also fitted with a disk brake rear with the lever on the tiller. This may be used on eventual emergency stops

If driving down a hill the **Entice** might drive faster than the maximum speed possible. In this case the control unit will slow the **Entice** down to reach the programmed maximum speed.

If the gas lever of the **Entice** is in neutral position the scooter is braked. The motor brake power is enough to stop the scooter and keep on its place on the maximum possible incline angle (12 degrees).

At rain, snow or other slippery road conditions, please brake gently to provide sliding danger.

Battery safety

When driving on low or empty batteries, to be seen on your battery indicator, the battery safety feature will be engaged. This provides battery damage through deep discharge. The engagement of this feature can be noticed by the decreasing maximum speed. Drive as little as possible in this condition. After thy system being engaged the batteries should be charged as soon as possible.

Freewheel

The **Entice** is equipped with a so-called freewheel function. This allows the **Entice** to be moved without using the engine. Push the backrest to move the scooter. In this freewheel position the scooter can not be driven electrically. You can engage the freewheel function by the freewheel lever on the rear side of the scooter, just below the cover (picture 35).



Picture 35

*It is important to first fully turn off the power before engaging the freewheel lever. The power needed to push the scooter is minimal. The brakes of the **Entice** are not in use during freewheel engagement. This can be reversed by turning the freewheel function off.*

Fault by engaged freewheel

If the **Entice** is powered when you engage the freewheel lever, the status indicator will indicate fault code 5. To erase the fault code and drive electrically please proceed as follows:

- first disengage the freewheel function (push the freewheel lever down)
- then, power off the system (this erases the fault)
- when the system is powered up the scooter is able to drive again

The Entice chair

The chair of the **Entice** is equipped with a number of adjustment possibilities which improves your seat and driving comfort considerably. The entire chair can be height adjusted in a range of 10 cm in 4 steps of 2,5 cm. This adjustment can be done by your dealer.

Adjust backrest angle

The backrest angle is stepless adjustable in a sitting position up to standard 105 degrees (picture 36). By replacing the hex bolt on the turning point this can be increased up to 135 degrees. The backrest can also be fully flipped forward to ease transport. On the right side of the chair (left shown on picture 36) is a lever. Pull it up and lean forward or rearward to adjust the desired backrest angle (picture 36). As soon as you reached it you release the lever. The backrest will fixate in your position.



Picture 36

Never operate the lever when you are not in the chair. The backrest will come forward with strength.

Armrest adjustment

The armrests can be fully flipped up (picture 37). Also the angle and the armrest height are adjustable. The armrests are fully flipped up by moving them up. The armrest angle is adjustable by the bolt on the inner side of the armrest. You can turn this bolt further out by hand (the arm rest angle will go down) or further in (the arm rest angle will go up). On the rear side of the arm rest tube is a turning knob. Turn it loose and adjust the arm rest to the desired height. Fasten the knob securely.



Picture 37

Adjust head rest (option)

The head rest is adjustable in three height positions.

Seat removal

Unlock the turning system of the chair as shown on the picture below (picture 38). You can pull the chair straight up and eventually move it around a little. Flipping back the armrests and folding down the backrest eases the removal. The chair can be handled on the lower side, symmetrical to the seat post.



Picture 38

The chair of the **Entice** weights around 16 kg. Please remember this when removing the chair. The chair can be lifted by putting your one arm around the backrest and grip firmly and the other arm under the seat. Folding the armrests and the backrest can ease the lifting.

Adjust tiller

You can adjust the tiller angle as follows (picture 39):

1. pull the small lever on the left side of the tiller
2. you can adjust the tiller with two hands by lowering or lifting it in the desired position
3. when you release the lever the tiller will fixate in the current position
4. the tiller can be fully folded down to ease transport

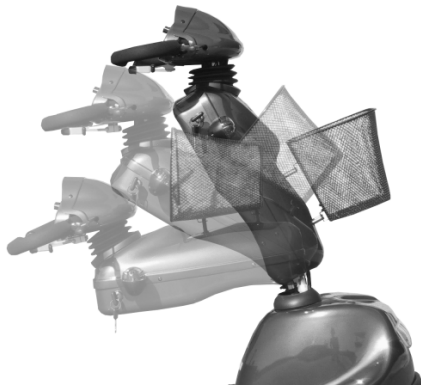

Picture 39

Moving the Entice manually

Manual movement of the **Entice** can be done by first engaging the freewheel mode and the power off. If this is not done the **Entice** can only be moved with great strength.

- put the freewheel lever in the up position. This engages the freewheel mode
- the **Entice** can now be moved freely by pushing the backrest
- after returning the freewheel lever and powering up the control unit the **Entice** is able to drive again.

The brakes of the **Entice** are not in use during freewheel engagement. This can be reversed by turning the freewheel function off.

Fault by engaged freewheel

If the **Entice** is powered when you engage the freewheel lever, the status indicator will indicate fault code 5. To erase the fault code and drive electrically please proceed as follows:

- first disengage the freewheel function (push the freewheel lever down)
- then, power off the system (this erases the fault)
- when the system is powered up the scooter is able to drive again

Charging the batteries

The **Entice** can be equipped with two dry 12 Volt batteries of maximum 73Ah. At daily use the dry batteries need no other maintenance than regular charge. The capacity of the batteries at 5 hours discharge is 70 Ah, at 20 hours discharge 75Ah.

The scooter is equipped with 2 Trojan type SG 70 B batteries. The battery connector type on the cable is Alex PVC, dimensions 40 x 20 mm.

Because the batteries are probably empty or partly charged when they arrive, it is of great importance to first fully charge the batteries. The scooter is fitted with a charger, standard delivered. If the batteries are charged using the below procedure, you will gain maximum lifetime, power and reach of the batteries.

1. Turn off the power of your scooter
2. Put the power support cable in a wall socket
3. Put the battery charge cable into the tiller (turn away the round cover) (picture 40).
4. When the battery charger is turned on the scooter will be charged. During charge the progress indicator will blink. A RED light means the charger is in use, a WHITE light means the scooter is being charged and a GREEN light means the scooter is fully charged.

The **Entice** can not be driven electrically with a plug in the charge socket. If the range of the **Entice** is strongly decreasing, the batteries need replacement. In this case you need to contact your dealer. It is not allowed to replace the batteries yourself. When a battery is leaking contact dealer immediately! Please consider the following when changing batteries: see that the connectors do not contact with each other. Make sure when connecting the batteries the connectors are correctly poled (++ and --). The **Entice** comes with a battery charger. If any problems occur please contact your dealer. It is not allowed to open the charger. The charge socket is indicated with a symbol on the tiller (picture 40a). The charger connection is indicated on the charger with a symbol (picture 40b):



Picture 40



Picture 40a

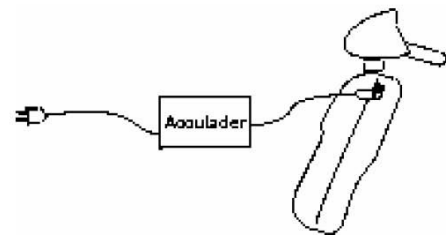

Picture 40b

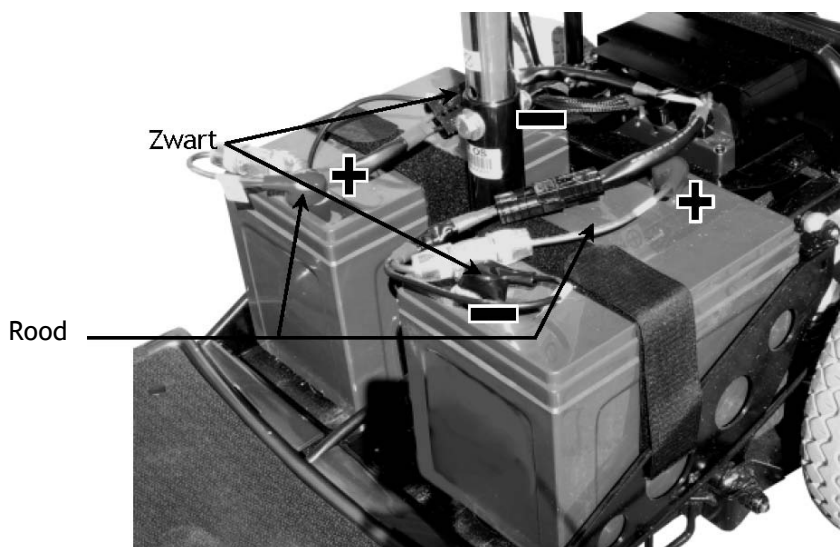

Picture 40c

Battery charger specifications:

- appropriate for the fitted batteries
- maximum nominal charge current: 24 Volt
- maximum nominal charge power: 6 Ah
- suitable for unguarded use

Opening battery space and removing batteries

The batteries of the **Entice** can be reached by removing the rear cover. First remove the chair as described on page 16. The rear cover can be removed. Replacement in reverse order. The batteries should be lifted on the lower side.

Storage

If the **Entice** is not be used for longer time, please consider the below remarks. The **Entice** needs to be stored with fully charged batteries in a dry and freeze free environment, in regard to freezing danger of the batteries. Always turn the **Entice** off during storage.

*The charge condition of the batteries should be checked regularly when the **Entice** is not used for a long time. If necessary the batteries must be recharged.*

*The **Entice** should never be left unnecessary in the bright sunlight. Parts like the upholstery or metal parts might get very hot. This also might shorten the tyres lifetime.*

Upholstery

The scooters upholstery should be cleaned with a mild cleanser. Weep the upholstery should with a moist cloth after cleaning.

Chassis and plastic parts

The chassis and the plastic parts, including the control panel, should only be cleaned with a light moist cloth. Dry the parts after that with a dry cloth.

*It is not allowed to clean the **Entice** with a high pressure hose or otherwise using too much water.*

*All the maintenance that can be done by the user is described in this chapter. If the **Entice** needs additional maintenance or repair you need to contact your dealer. It is not allowed to perform any other than the herein described tasks on the **Entice**.*

Charging the batteries

Always charge the batteries regularly and on time. This preserves the maximum charge capacity and increases the lifetime of the batteries. For charging instructions see page 17.

Tires

It is very important to check the tire pressure or tire damage regularly. When any damage might occur (for instance caused by a nail or glass), contact your dealer immediately.

The scooter tires should always be on the prescribed pressure (see chapter technical data). Driving with low pressure tires causes bad driving and steering characteristics.

The tires should never be inflated over the maximum tire pressure. The tire might get off the rim or explode.

Other maintenance

Please leave any other maintenance to your dealer. Adapt the needed maintenance to your scooter together with your dealer.

If any lubricant should leak, for instance from the gear box, please contact your dealer immediately and don't drive the scooter again.

Replacement parts

All **Entice** parts, including electronic components, are securely adapted to each other and tested. This results in a quality scooter with a long lifetime. This quality, safety and lifetime can only be preserved by using only original replacement parts.

*Not using original parts could result in decreased liability from the **Entice** and reduced safety. Also due of the warranty.*

All replacement parts can be ordered by your dealer at Van Os Medical B.V..

Maintenance frequency

This schedule has been made to give you a survey of the maintenance that should be done to the **Entice** . The yearly maintenance should be done by your dealer.

Check	Weekly	Monthly	Yearly	By whom
Battery charger connection			✓	Dealer
Bolts and nuts			✓	Dealer
Tire wear		✓		User
Tire pressure	✓			User
Wiring and connections			✓	Dealer
Clean upholstery		✓		User
Illumination and indicators	✓			User
Bearings			✓	Dealer
Engine			✓	Dealer
Battery poles		✓		Dealer
Clean chassis parts and covers		✓		User
Driving program			✓	Dealer
Suspension			✓	Dealer
Freewheel and parking brake			✓	Dealer

Faults

The dashboard contains a status indicator. If this lights up green without blinking the **Entice** is ignited and there are no problems. In case of a fault the status indicator indicates a fault by blinking codes. If the status indicator shows a fault, the first thing to do is turn off the power of the **Entice** and ignite again.

If the indicator shows another fault, please count the blinks. These show a code which indicates a fault. The flash code list below shows all the meanings of the flashes. The list also contains possible causes and an eventual solution of the problem. If you are unable to solve the problem with help of this list, please contact your dealer.

Number of blinks	Fault	Scooter condition	Remarks
1	Charge battery	Driving possible	Battery voltage lowered to less than 23.3 V, charge batteries soon
2	Battery voltage too low	Driving not possible	Battery voltage lowered to less than 16.5 V, charge batteries immediately
3	Battery voltage too low	Driving not possible	Battery voltage increased higher than 32 V. Probably defect charger.
4	Current limit time out	Driving not possible	Detector detected shortcut in the motor. Warn dealer.
5	Brake fault	Driving not possible	Check if freewheel is connected
6	Gas pot not in neutral at power up	Driving not possible	Contact dealer
7	Speed pot error	Driving not possible	Contact dealer
8	Motor volts error	Driving not possible	Contact dealer
9	Other internal error	Driving not possible	Contact dealer
10	Push too fast fault	Driving not possible	Turn off the scooter and restart

All Van Os Medical products are built for a long and durable lifetime. However, during time reparation and maintenance to your **Entice** will not be enumerative any more. Your dealer will contact you in time for this. When recycling the **Entice** your should consider the below points:

- at scooter recycling the current or local precautions should always be followed
- the **Entice** only contains known materials. A couple of this materials, if collected separately, can be recycled
- at development and build of the **Entice** for all used materials were known waste disposal possibilities and no risks were known for recycling persons, not containing the batteries

*Make sure during recycle of the **Entice** the batteries do not get damaged. They should be offered to a certified instance or company for further disposal. When dealing with batteries always take the needed precautions for protection of yourself and the environment.*

Range

The range of the **Entice** (± 60 km) depends on the following factors:

- condition of the batteries
- weight on the chair (user, luggage etc)
- average driving speed
- driving style
- surface
- environment temperature
- driving conditions (hilly or flat, gravel or smooth asphalt)

Standard programmed driving parameters

The **Entice** controller is equipped with a microprocessor. This can be indicated as the 'brain' of the scooter. Inside this microprocessor a number of parameters can be adjusted. Some of these parameters have consequences for the driving characteristics of the **Entice**. Van Os Medical B.V. equipped the **Entice** with a standard program. If this program does not satisfy you, it can be adjusted by use of a programmer box to adjust all parameters to your desires.

The values of the parameters have been carefully chosen. Extreme altering of the parameter data could result in unstable driving habit. Small changes of the parameters are allowed.

Warranty precautions

These warranty precautions are in accordance with all other product specific warranties and are just applicable to the first owner. If a none specified, to the product belonging warranty claim will appear, this claim will judged by Van Os Medical B.V. during the warranty period. During the warranty period the replacement parts can only be guaranteed until the end of the regular warranty period. All appearing warranty will be limited to the replacement or reparation of the defect parts. Van Os Medical B.V. can never be held responsible for any consequence such as damage or incidental damage, in what way ever.

Van Os Medical B.V. only guarantees replacement parts.

This warranty gives you specific lawful rights. You must be aware of the fact that these rights can change from country to country. Some lands do not accept a limited warranty concerning incidental or consequential damage, or the time limit of the warranty. In that case the warranty period and / or the exception of the warranty will be adjusted. For warranty and service you need to contact the authorised Travelux® dealer, who supplied the Travelux®. If during a warranty period reparations are done by another company than Van Os Medical B.V. or a not by Van Os Medical B.V. approved company, every right on warranty comes to an end. In case of service and warranty is not given to satisfaction by your dealer, please contact Van Os Medical B.V. We will try to get to a satisfying solution for both parties.

MANUFACTURERS DECLARATION OF CONFORMITY

For

Product identification

Product : ***Electrically propelled scooter***
Brand : ***Excel***
Model/type : ***Entice 3***
Version : ***A***

Manufacturer : Name ***Van Os Medical BV***
Address ***Koperslagerij 9***
4651 SK STEENBERGEN
Country ***The Netherlands***

EU representative Name ***Van Os Medical BV***
W. Van Os
Address ***Koperslagerij 9***
4651 SK Steenbergen
Country ***The Netherlands***
Function: ***Director***

Technical constructed file

Prepared by : Name ***P. van Os***
Function : ***research and development***
Date : 01-10-2006
TCF : 01-10-2006

Means of conformity

The product is in conformity with Directive 93/42/EEG based on the use of a Technical construction file in accordance with Article 9 (Class I products) of the Directive

Signature of EU representative :

Place : Steenbergen
Date : 01-10-2006
Number : VOS.TCF.EX.01



Technical data

Type indication: Entice 3
12 km/h power scooter

Technical data according to ISO 7176-15

Dimensions ready to drive (lxbxh):	1170x640x1250
Dimensions minimum (lxbxh):	1170x640x1000
Total weight without batteries:	± 58 kg
Total weight with batteries:	± 98 kg (met 50Ah batteries)
Mass removable part:	± 16 kg (seat)
Static stability downhill:	15°
Static stability uphill:	15°
Static stability side hill:	15°
Dynamic stability uphill:	15°
Maximum safest incline:	12°
Range:	35 km*
Maximum obstacle height:	100 mm (forward)
Maximum threshold drive off:	100 mm
Ground clearance:	100 mm
Maximum adjustable forward speed:	12 km
Maximum adjustable rearward speed:	5 km
Minimum braking distance from maximum speed:	3,3 meter
Seat angle:	3°
Seat depth standard seat:	500 mm
Seat width standard seat:	500 mm
Seat height minimum:	640 mm from the floor
Seat height maximum:	710 mm from the floor
Back rest angle (adjustable):	90 – 135° adjustable
Backrest height:	490 mm
Armrest height:	170 - 240 mm
Front side arm pad to front side backrest:	310 mm
Turning radius:	1310 mm
Maximum user weight:	120 kg
Operating power:	1 N with hand control
Intended use:	Outdoor, class C
User area:	Europe

* At average use in combination with dry batteries 50 Ah. See page 21

The scooter further fulfils the following standards:

ISO 7176- 8: demands and testing methods for static, shock and fatigue strength

ISO 7176- 9: climate tests for scooters

ISO 7176-14: drive and control units for scooters

ISO 7176-16: demands for burn resistance

Other technical data

Battery space(l x w x h):	(2x) 197.5 x 165 x 170 mm
Mass of batteries:	± 20 kg per pc (dry batteries 50 Ah)
Electronic control:	Rhino 110
Engines:	24 VDC, 295 Watt, 5100 rpm
Wheel size front:	10" (260*85)
Wheel size rear:	10" (260*85)
Tire pressure (front):	50 PSI
Tire pressure (rear):	50 PSI
Minimum battery capacity:	50Ah

Standard program for Entice 3

Setup menu	
Acceleration	3
Deceleration	6
Forward speed	9
Reverse speed	4
Reduce speed	5
Buzzer volume	10
Motor resistor	30
Sleep time	30
Maximum current	110
Park brake delay	6
Soft start period	50
Pot neutral	128
Std speed pot FSD	72
Std speed pot dead	20
Alt speed pot FSD	72
Alt speed pot dead	20
Options menu	
Single ended pot	off
Stand Speed Pot	off
Motor reverse	off
Pot reverse	on
Speed derating	on
Brake checking	on
Load compensation	on
Motor derating	off
Enable sleep	on
Check for slope	off
Current limit timer	on
Enable soft start	on



Van Os Medical B.V.
The Netherlands
Koperslagerij 9
4651 SK Steenberghe NB
Tel: +31 (0) 167 57 3020
Fax: +31 (0) 167 57 3381
info@vanosmedical.nl
www.vanosmedical.com

Dealer:

EXCEL



EXCEL

VAN OS

For international customers:

VAN OS MEDICAL B.V.
Koperslagerij 9
4651 SK Steenberg
The Netherlands

Tel.: +31 (0) 167 573020
Fax: +31 (0) 167 573381
E-mail: sales@vanosmedical.nl

For UK and Ireland:

VAN OS MEDICAL UK LTD.
42-44 OuseGate
YO8 4NH Selby, United Kingdom

Tel.: +44 (0) 1757 701177
Fax: +44 (0) 1757 706011
E-mail: sales@vanosmedical.com

www.vanosmedical.com