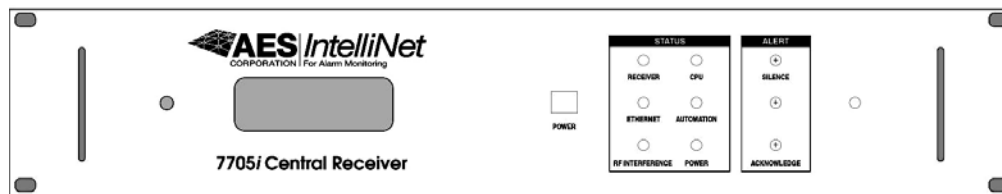




# AES 7705i MultiNet Receiver System



## User Manual



AES Corporation

285 Newbury Street. Peabody, Massachusetts 01960-1315 USA

Tel (978) 535-7310. Fax (978) 535-7313

Copyright 2006/2007 , All rights Reserved

**NOTICE TO USERS, INSTALLERS, AUTHORITIES HAVING  
JURISDICTION, AND OTHER INVOLVED PARTIES**

**This product incorporates field-programmable software. In order for the product to comply with the requirements in the Standard for Control Units and Accessories for Fire Alarm Systems, UL 864, certain programming features or options must be limited to specific values or not used at all as indicated below.**

<b>Program Feature or Option</b>	<b>Permitted in UL 864 (Y/N)</b>	<b>Possible settings</b>	<b>Settings permitted in UL 864</b>
Alarm Automation Heartbeat Signal Frequency: Serial or IP	Y	0-90	As configured by UL 1981 Central-Station Automation Systems Requirements
Data Type:	Y	Security, GPS, USDI, Others in pull down menu	Security
Old Alarm Delivery Options	Y	All, Subscriber controlled Never	All
Radio Packet Life	Y	0-99	0 – No Time Out for Alarm, Trouble or Restoral

**Notes:**

**For Alarm Automation references throughout this manual,  
Alarm Automation output must be connected to a  
UL 1981 Listed Alarm Automation System**

**For UL Central Station Burglar Alarm applications,  
Opening/Closing Signals shall be sent using an alternate communication  
means that provides for premises acknowledgement (ring back)**

**This product shall be installed in accordance with NFPA 72,  
NEC, UL 827 and all applicable local codes**

For compliance with UL Central Station Burglar Alarm applications,  
a workstation is required to be able to determine subscriber status.  
The workstation shall be UL Listed ITE equipment.

# AES 7705i MultiNet Receiver

## Table of Contents

<b>1.0</b>	<b>Product Description:</b> .....	<b>6</b>
1.1	About AES IntelliNet: .....	6
1.2	MultiNet Receiver: .....	6
1.3	7170 IP-Link Transceivers: .....	7
1.4	Document Conventions: .....	7
<b>2.0</b>	<b>Safety Considerations:</b> .....	<b>9</b>
<b>3.0</b>	<b>Technical Specifications:</b> .....	<b>9</b>
3.1	Front Panel:.....	10
3.2	Rear Panel:.....	12
<b>4.0</b>	<b>Installation and Setup :</b> .....	<b>14</b>
<b>4.1</b>	<b>Software Installation:</b> .....	<b>15</b>
<b>5.0</b>	<b>System Startup and Access:</b> .....	<b>19</b>
5.1	1 <sup>st</sup> Time Notes:.....	19
5.2	Power up:.....	19
5.3	Power Down - Information:.....	20
5.4	Local Access and Login: - Initial Setup .....	20
5.5	Linux Command line:.....	21
5.6	Common Linux Commands: .....	21
5.7	The GUI Desktop and the AES Menu:.....	22
5.8	Start the Terminal Program: .....	23
5.9	Setting Time: .....	24
5.10	Synchronizing Time: .....	24
5.11	Time Zone: .....	24
5.12	Review your TCP/IP Configuration: .....	25
5.13	Factory Default TCP/IP Settings.....	25
5.14	Suggested TCP/IP Settings for Second MultiNet Receiver.....	26
5.15	A note on DHCP.....	26
5.16	Configure TCP/IP, Linux Network Configuration:.....	26
5.17	Testing TCP/IP Configuration:.....	29
5.18	User Logout from directly attached keyboard & monitor: .....	30
5.19	User Logout from Workstation Access: .....	30

<b>6.0</b>	<b>Admin GUI for Configuration and Administration:</b>	<b>31</b>
6.1	Server Configuration	33
6.2	Define Business Units: (you must have at least one)	34
6.3	Add a Business Unit – Alarm Automation Settings	37
6.4	Business Unit Overview	42
6.5	Modify a Business Unit	43
6.6	Subscriber Database Setup	44
6.7	Alarm Data	47
6.8	Close Your Browser When Finished With Admin GUI:	48
<b>7.0</b>	<b>Workstation Access and Login:</b>	<b>49</b>
7.1	Programs for Access Via a Workstation	49
7.2	Installing VNC Viewer:	50
7.3	Using VNC Viewer:	51
7.4	After login:	52
<b>8.0</b>	<b>MultiNet Receiver Programs and Utilities:</b>	<b>53</b>
8.1	MultiNet Specific Programs:	53
8.2	MultiNet Utility Programs and Scripts:	54
8.3	Special Purpose Circuits:	56
8.4	AES Menu in the GUI Desktop:	57
<b>9.0</b>	<b>Managing Users:</b>	<b>58</b>
9.1	Adding a user:	58
9.2	Retrieving user Display Number and Password:	58
9.3	Changing a user's Password:	59
9.4	Change Admin GUI Access - Username and Password:	60
9.5	Deleting a User:	60
9.6	Test new user login:	61
<b>10.0</b>	<b>Admin GUI Database Functions:</b>	<b>62</b>
10.1	Subscriber Overview	62
10.2	Routing Table Screen:	63
10.3	IP-Link Status Screen:	64
10.4	Get Signal History:	64
10.5	Close Your Browser When Finished With Admin GUI:	65
<b>11.0</b>	<b>IPLinkCtrl (ipctrl) Network Management Software:</b>	<b>66</b>
11.1	IPCtrl Function Groups:	67

11.2	Common data entry/selection menus and pop-ups:.....	67
11.3	Using the pick list pop up to Select a Subscriber ID.....	68
11.4	Selecting a Route for Communication with a Subscriber Unit .....	68
11.5	The Message Function Group: .....	69
11.6	Control Function Group.....	71
11.7	Programming Function Group:.....	74
11.8	Data Radio Function Group:.....	86
11.9	System Function Group.....	90
11.10	Interpreting Screen Messages.....	91
<b>12.0</b>	<b>Operation.....</b>	<b>92</b>
12.1	Manual Operation.....	92
12.2	Automatic Operation .....	92
<b>13.0</b>	<b>Warranty and Service Procedure: .....</b>	<b>93</b>
<b>APPENDICES.....</b>		<b>94</b>
<b>Appendix A Common Linux Commands .....</b>		<b>95</b>
<b>Appendix B Server-generated LCD Display Messages. ....</b>		<b>96</b>
<b>Appendix C Software installation Instructions.....</b>		<b>98</b>
<b>Appendix D Sharing the Serial Port with additional Business Units.....</b>		<b>99</b>
<b>Appendix E Alarm Output Codes Produced by the MultiNet receiver .....</b>		<b>101</b>
<b>Appendix F Printer Messages Produced by the MultiNet receiver.....</b>		<b>111</b>

## 1.0 Product Description:

This document discusses the installation, configuration and use of the various programs and hardware in the AES MultiNet Receiver uses. This Receiver is the heart of the **AES MultiNet** system. All properly configured 7170 IP-Link Transceivers ([see section 1.4](#)) will send their received **AES•IntelliNet** packets to this Receiver via TCP/IP over a LAN, WAN, the Internet or if necessary and equipped, via Modem (as backup), for distribution to the appropriate application or external system.

### 1.1 About AES IntelliNet:

**AES IntelliNet** is a two-way data radio network for the monitoring of alarms or transmission of specialized data packets. It is faster and more reliable than telephone and cellular systems, which are subject to both tampering and general failure. Phone lines may still be used for backup.

What makes the patented AES system unique are its “smart” radio communicators, called subscriber units. Each subscriber unit is connected to an alarm panel or specialized data port. Alarm information or data is transmitted by radio to the central receiver or an “IP-Link Transceiver” ([see section 1.4](#)). If a subscriber unit is too far away to reach the central station or an IP-Link Transceiver directly, its message is relayed by another subscriber unit closer to or in better communication with the central station or other closer units. This unique built-in “repeater” capability creates a highly rugged, adaptive security network. The system adjusts itself to forward messages by the shortest and best available route. The “smart routing” capability is completely automated, with no special programming needed. Also, by eliminating the need for dedicated repeaters and towers, the AES system dramatically reduces the cost of setting up and operating a wireless monitoring system.

### 1.2 MultiNet Receiver:

The AES 7705i MultiNet Receiver with integrated PC, Linux operating system and IP-Link programs is housed in a 19” rack mountable enclosure. This device acts as the central receiver. It is a specialized Linux based server with specific programs running that acquire data packets from one or more IP-Link Transceiver(s). **AES** Linux server software reads subscriber data from these IP-Link transceivers via a TCP/IP socket connection. The server programs categorize the incoming data and forward it to customer systems for further processing. An example of this activity is alarm processing, where the server software identifies an alarm received by an IP-Link, sent by a Subscriber attached to an alarm panel, processes it, then forwards an alarm message to a customer’s alarm automation software.

The software installation consists of several AES programs that process the data and a web-based GUI for server administration and subscriber configuration. The AES programs rely on open system components, including the Apache web server with php, and the MySQL database, to process the subscriber data.

Other programs in the MultiNet receiver evaluate and distribute the data to an appropriate application on this machine or another located on the LAN, WAN or Internet. These other applications may re-distribute the data, store it in a database for later retrieval, send it out a local RS232 serial COM port, send it out a printer port or perform whatever function the application is designed. A single MultiNet Receiver can have multiple IP-Link Transceivers installed locally or anywhere connected by a TCP/IP connection. This capability allows the *IntelliNet* network to be expanded virtually to any location desired that is serviced by the LAN, WAN or Internet.

### 1.3 7170 IP-Link Transceivers:

These units communicate to the MultiNet Receiver via a direct Ethernet connection, LAN, WAN or the Internet. Models have an integrated Modem to communicate using a phone line if the TCP/IP connection is down. The IP-Link acts much like a subscriber that re-transmits its received data packets via the TCP/IP connection rather than via an RF transmission. This allows the IP-Link Transceiver to be located outside of RF communication with a central station receiver and the expansion of the IntelliNet system into previously unreachable locations. They should be installed with the same care that a central station receiver would as they are usually the primary path to the central receiver location. Multiple IP-Link Transceivers can be installed in a single RF cloud to act as backup or to provide multiple paths for subscribers in a geographical area. Each IP-Link Transceiver can operate at the same frequency or at another. Operating at other frequencies allows for an overcrowded region to get a new clear frequency and still be able to be managed by the same receiver. It also allows the expansion into other regions, states, countries or islands where regulations may require operation at a different frequency than your other IP-Link Transceivers.

### 1.4 Document Conventions:

<Key> Characters between angled brackets refer to a specific key on the keyboard.

Example <Enter> means to press the Enter Key.

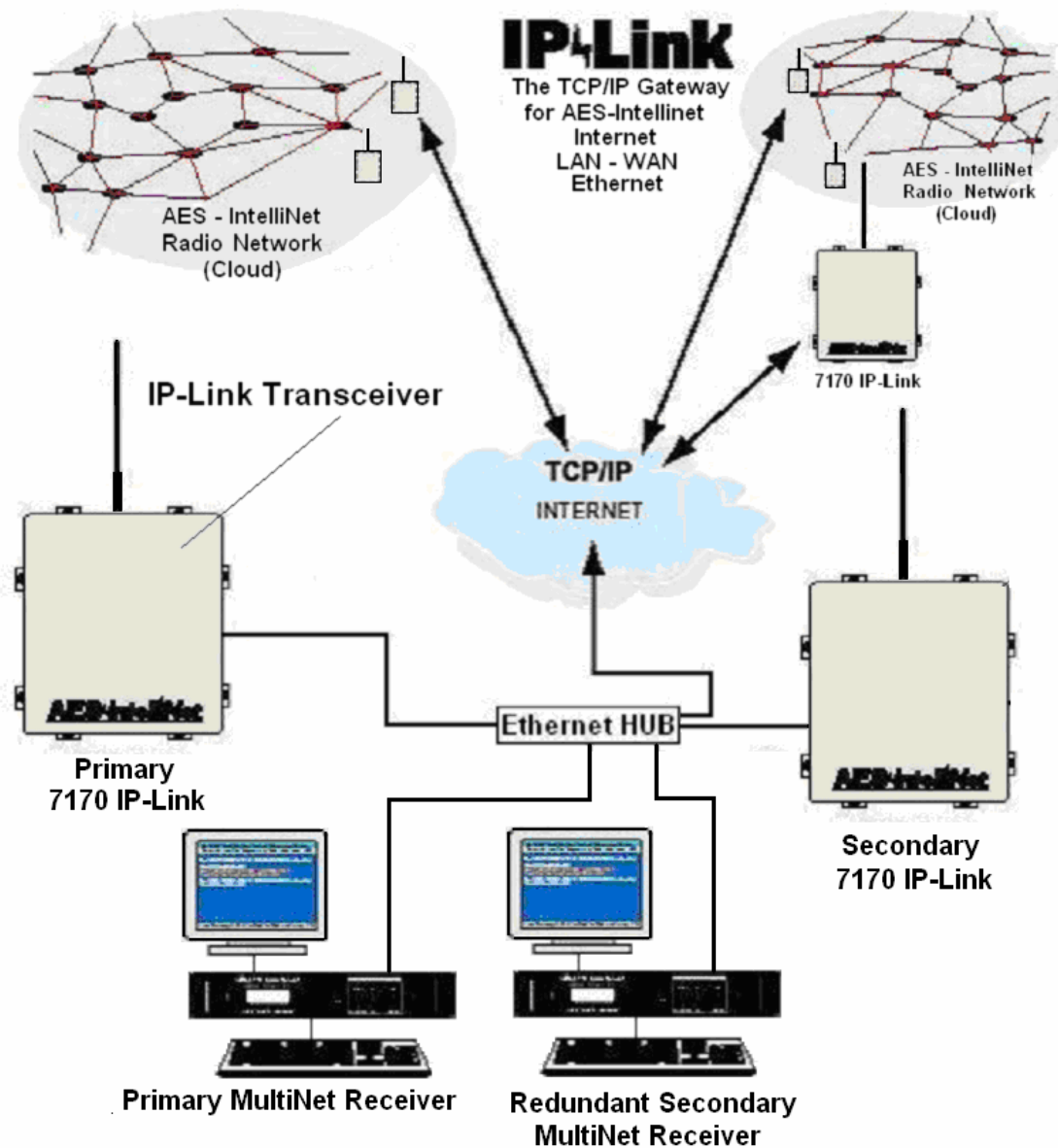
{variable} Characters between these braces refer to a value that will vary dependant on any number of circumstances or configurations.  
Example: {username} means to replace {username} with the appropriate user name.

Example 2: {IP Address} would require a valid IP address be typed in place of the label.

[Screen Text] Square brackets have several uses. Occasionally refers to a Graphical Button, usually selected by clicking on the screen graphic.

Also used to indicate a selection available by choosing from an available list.

May also be used to show actual characters displayed.



***Typical MultiNet System***

It is highly recommended and required for UL systems that a redundant MultiNet Receiver be operational at the head end and that any location of 7170 IP-Link Transceivers have at least two for the purpose of redundancy.



## 2.0 Safety Considerations:

All equipment must be installed in accordance with National Electric Code, applicable UL Standards and local building codes. Unplug power before opening enclosures to avoid electrical shock.

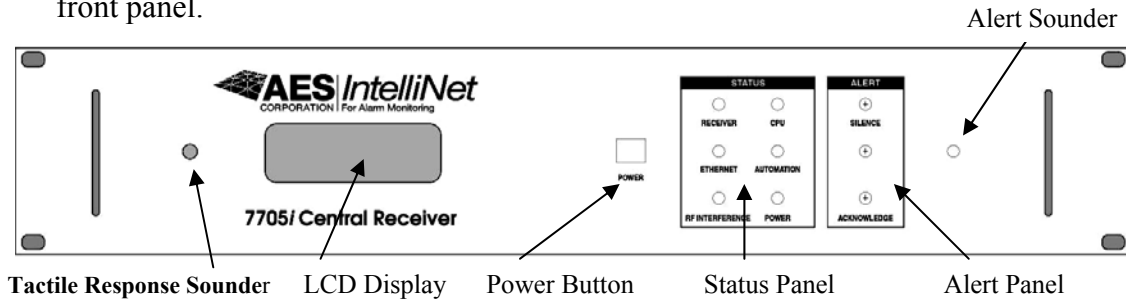
## 3.0 Technical Specifications:

The 7705i is in a standard 2U 19" rack enclosure configuration.

Operating voltage:	120 VAC, 60 Hz. +/- 10%
Operating current:	0.6 Amps
Operating Temperature Range:	13° to 35° +/-2 C 55° to 95° +/-3 F
Storage temperature Range:	-10° to 60° C 4° to 140° F
Power Consumption:	200-Watts Maximum
Physical Dimensions:	19" Wide X 3.5" High (2U) X 12.24 (13.25 including rack handles)
Minimum Rack Depth:	Approximately 16" to allow for cables and connectors.
Approximate Weight:	9 pounds
Encryption:	AES 128 Bit

## 3.1 Front Panel:

The front panel has the user display and controls. [Figure 3-1](#) shows a view of the front panel.



**Figure 3-1**

**3.1.1 LCD Display:** The LCD is a 4-line display with 20 characters per line. It shows messages for the 7705i. Use this in conjunction with the Alert panel to interpret and acknowledge messages. There is also a tactile response sounder to provide audible confirmation of a successful button activation.

In most modes of operation, the top line will be constant and usually displays the LCD firmware version number and AES copyright. Example: 

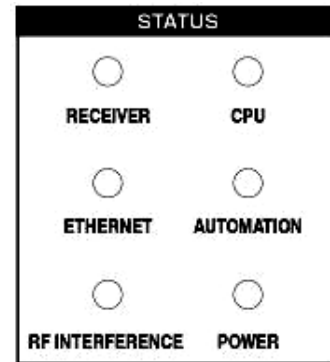
REV #.## (C) 2005-06 AES
--------------------------

Other lines will be used to display messages generated by the server. Refer to [Appendix B](#) for a detailed explanation of server-generated messages displayed on the LCD.

**3.1.2 Power Button** is used to turn On/Off and Reset the computer motherboard integral to the MultiNet Receiver. Push to start up a downed unit. Press and hold for 10 seconds to perform an emergency shutdown (Not recommended for non-emergencies).

**3.1.3 Status Panel:** Contains LEDs that indicate fault conditions as described below: See [Figure 3-2](#).

When any of the Status LEDs are activated to reflect a failure, the LED on the Alert panel will also be activated, causing the Alert Sounder to activate. Pressing SILENCE will momentarily silence the Alert Sounder for 30 seconds until message is cleared. Pressing ACKNOWLEDGE will clear the Alert LED. The status LED will not be “cleared” until the failure has been corrected.



**Figure 3-2**

- **Receiver:** Red Led - Indicates a hardware or system fault in the server. These faults will include Printer Offline and LCD display faults.
- **CPU:** Red Led - Indicates that the CPU or internal processor has performed a reset either manually initiated or automatically by the internal watchdog circuit. Pressing the Acknowledge button turns off this LED.
- **Ethernet:** Red Led - Indicates a fault condition with the Ethernet connection as detected by a missing check-in from a 7170 IP-Link Transceiver.

- **Automation:** Red Led - Indicates that the Alarm Automation process is unable to get Acknowledgements from a designated alarm monitoring system.
- **RF Interference:** Red Led - Indicates that an RF interference condition exists and that signals may be hindered. RF interference is a condition where the Carrier Detect (CD) in the transceiver is active for more than 20 seconds. This LED will turn off if CD turns off for 100 milliseconds.
- **Power: Green Led** - Indicates that proper power is detected at the monitored points within the 7705i.

**3.1.4 Alert Panel:** This section of the front panel contains an LED and two Push Button Switches. The LED illuminates to indicate the existence of unacknowledged message(s). The switches allow for Silencing and Acknowledgment as described below: See [Figure 3-3](#). There is also an audio device associated with these functions, which is located behind the small hole to the right of the Alert Panel.

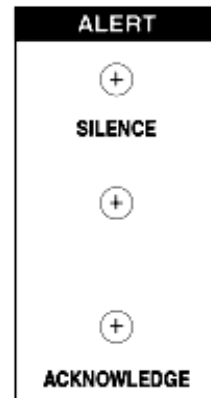
A message queue exists within the MultiNet receiver to hold messages that are in need of a user's response. A user must acknowledge these messages manually when alarm automation is offline and that automation system is not acknowledging the reception of those messages using the configured communication protocol.

- **Tactile Response Sounder:** A short beep sound will be heard from the tactile response sounder located near the LCD any time a button press in this panel is accepted. There may be a short delay between the press and the sounder's beep.
- **Silence Button:** Is used to silence the internal alert sounder.

**If the Silence Button does not silence the Alert Sounder,** it may be due to an overheating condition. Other MultiNet Receiver functions may appear normal. The unit must be shut down and the cause of the overheating condition must be corrected before continued use. To shut down the unit, press the Power Button on the front panel for 10 seconds or switch the power switch on the rear panel to the Off position. Contact AES for service

- **Alert LED: Red Led** - Indicates that a condition exists that needs attention or that the CPU LED is on. Refer to the Alert messages on the LCD display for details.
- **Acknowledge Button:** Is used to Acknowledge the message that is currently displayed on the LCD Display. This is a function that is only required when automation is offline. Once acknowledged the current message is removed and the next message (if any) in the message queue is displayed.

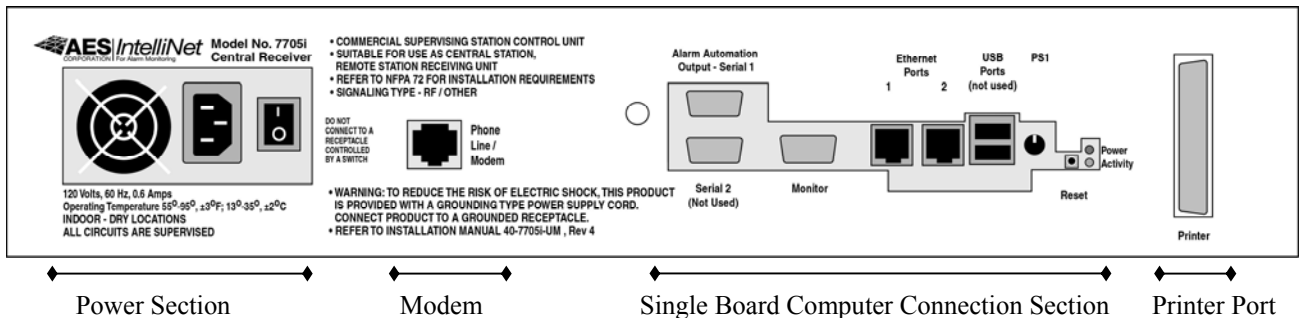
When alarm automation is online, pressing this button will turn an illuminated Alert LED off.



*Figure 3-3*

## 3.2 Rear Panel:

The rear panel contains the connectors used to attach external connections, peripherals such as the monitor, keyboard, mouse and power. The main power switch is also located on the rear panel. The rear panel is divided into at four sections as outlined below. [Figure 3-4](#) shows a view of the rear panel.



**Figure 3-4**

**3.2.1 Power Section:** Contains the power input connector and power supply On/Off switch as described below: Also contains the Power Supply fan.

- **Power input connector:** Plug the female end of the supplied AC power cord into this connector and the male end of the power cord into a 120 VAC, 60 Hz receptacle supervised by a UL Listed 864 UPS or a UL 1481 power supply.  
**Do not connect to a receptacle controlled by a switch.**
- **Power On/Off switch:** This switch controls the internal power supply. When in the off ( O ) position power supply output is interrupted. When in the On ( | ) power is provided to the internal electronics including the motherboard.
- **Power Supply Fan:** This fan must be kept clear of obstructions to permit unobstructed flow of air.

**3.2.2 Modem Section:** Contains a single telephone jack connector:

- **Phone line/Modem Jack:** Plug a telephone cord into this connector with the other end plugged into an active telephone Jack. This is used to provide a backup Modem connection for IP-Link Transceivers that cannot communicate via the Internet or TCP/IP.

When connecting the 7705i MultiNet Receiver's modem to a telephone line, use only 26 AWG or larger wire. A UL Listed 497A Secondary Protector is required to be installed on the incoming lines. Installation shall be in accordance with the NEC Article 800, the manufactures installation instructions and in accordance with all local codes.

**3.2.3 Single Board Computer Connector Section:** Contains connectors for computer peripherals.

- **Serial Port 1 / (COM 1) Upper:** [/dev/ttyS1] Typically used to connect to alarm monitoring system for signals communicated via RS-232.  
See [Appendix E](#) for a list of Alarm messages generated.
- **Serial Port 2 / (COM 2) Lower:** Unavailable. Not Used.
- **Monitor, CRT (J8):** Plug the video monitor into this Jack. \*
- **Ethernet Port 1 (J10) [eth0]:** Can be used for a dedicated crossover Ethernet cable connection to a 7170 IP-Link transceiver using no additional network hardware or as a connection to an Ethernet Hub/Switch using a standard straight through Ethernet cable.  
Pre-configured factory default to static IP address 192.168.0.101.
- **Ethernet Port 2 (J11) [eth1]:** This Port is not used.
- **USB ports 0 & 1 (0 is Lower):** Not Used
- **PS/2 Keyboard/Mouse port (J16): \*** Use supplied Y-cable to connect a PS/2 keyboard and a mouse. These devices are used during configuration. Once configured access to the MultiNet Receiver is done through a network workstation.
- **Reset Switch:** Press and hold for 2 seconds to perform a hard reset. Do this only in the event of a lockup condition when proper shut down procedure cannot be accomplished.

**3.2.4 Printer Port Section:** Contains a single printer connector:

- **Printer Port:** Plug the Db-25 male end of the printer cable connected to a supported parallel printer. Attach only a printer Listed by UL for “Signaling use” under UL 864, such as an AES 75-0101.

See [Appendix F](#) for a listing of generated messages.

Note: \* These are to be used for initial setup only and are not to remain connected.



## 4.0 Installation and Setup :

**A separate “Initial Installation and Setup Guide” is provided to guide you through the initial installation and setup.**

A standalone Receiver requires a monitor, keyboard and mouse for user interface. See [Figure 4-1](#). The standalone configuration is not recommended by AES Corporation for anything other than initial setup and preliminary testing of the system. Once properly configured and connected to a LAN, a network workstation is used to access and configure the receiver remotely. See [Figure 4-2](#) and [Figure 4-3](#).

A printer is also required for printing any output directed to the printer port. Refer to [Appendix F](#) for a listing of printed messages. Ethernet port(s) are integrated into the PC, and are used to connect to the IP-Link Transceiver(s) and external applications on remote servers or systems via direct connection, LAN, WAN or the Internet.

**A system, while it may not have a keyboard, video monitor or mouse connected during normal operation, will require these peripherals connected directly for initial setup until remote access is accomplished. They may also be needed later for occasional configuration modifications.**

The 7705i, monitor and any network related equipment shall be connected to a suitable UL-UPS to maintain power during power outages.

In a Dual system, each 7705i and the 7170 IP-Link Transceiver shipped, is configured exactly the same. At least one set must be modified to operate the two pairs together in the same TCP/IP network. Each device in the system must have unique TCP/IP addresses. Each 7170 must have a unique Unit ID for the IntelliNet Network it will operate in.

Figures 4-1, 4-2 & 4-3 on next pages illustrate some typical system installations. The illustration on [page 8](#) also illustrates a typical system.

## Notes:

- **Power Line, router/ switch, and telephone connections shall not leave the room where the AES equipment is installed. This must be accomplished by co-locating outlets and interfacing equipment in the room where AES equipment resides.**
- **7705i must be installed in a UL Listed metal rack-mounting cabinet that complies with UL864. The cabinet must be provided with integral outlets and the ability to connect AC input via conduit. All wiring exiting the cabinet must be in electrical conduit. Be sure non-power limited and power limited wiring are separated by at least 1/4 inch.**
- **All equipment shall be connected to a UL Listed UPS (UL 864) or UL 1481 power supply. In addition, the central station shall have a generator to maintain power for the receiving equipment and environmental controls for a period up to 24 hours or longer.**
- **A UL Listed UPS or generator to supply 24 hours of standby must be installed and utilized at the monitoring station. If the primary power source at the monitoring station is lost or otherwise faulted, this condition must be obvious to the operator on duty.**
- **Equipment Location: A UL 7705i MultiNet Receiver must be installed in a room where operators can properly hear the Audio Alert Sounder.**
- **When connecting the 7705i MultiNet Receiver's modem to a telephone line, a UL Listed 497A Secondary Protector is required to be installed on the incoming lines. Installation shall be in accordance with the NEC Article 800, the manufactures installation instructions and in accordance with all local codes.**
- **When connecting the 7705i MultiNet Receiver's Ethernet ports to a network, a UL Listed 497B Secondary Protector is required to be installed on the Ethernet cable. Installation shall be in accordance with the NEC Article 800, the manufactures installation instructions and in accordance with all local codes.**

## 4.1 Software Installation:

All necessary software is pre-installed on your 7705i.

If your system has a catastrophic failure it may require the reinstallation of the Linux operating system and the specialized IP-Link software programs. BIOS settings should also be checked to confirm that the unit would initialize and operate properly. Routine backing up of the databases to another storage device would be essential in any successful reinstallation or recovery process.

Contact AES Technical Support if you need assistance with software installation or BIOS settings.

Figure 4-1

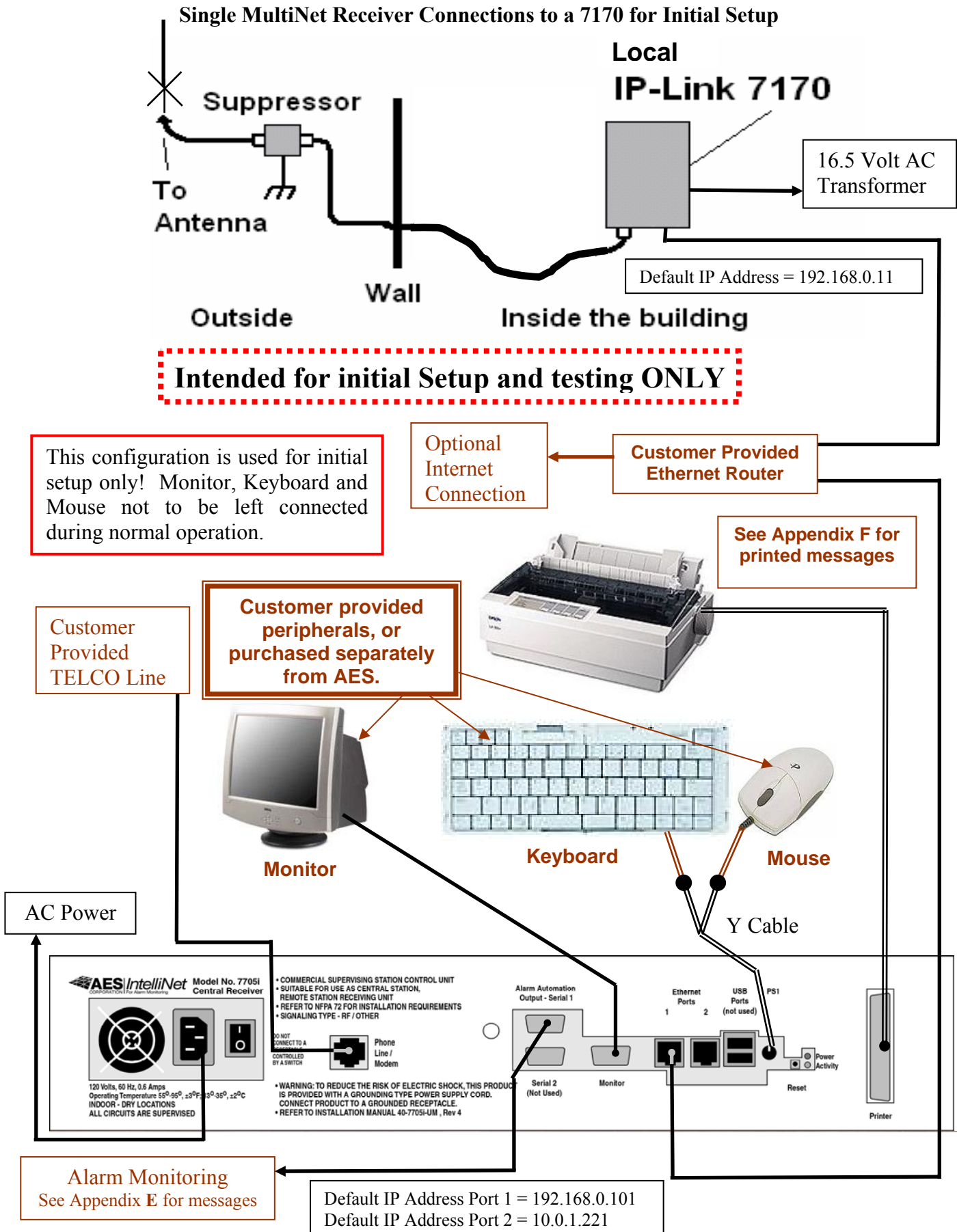




Figure 4-2

Dual MultiNet Receiver Connections to Local 7170 IP Links thru a LAN

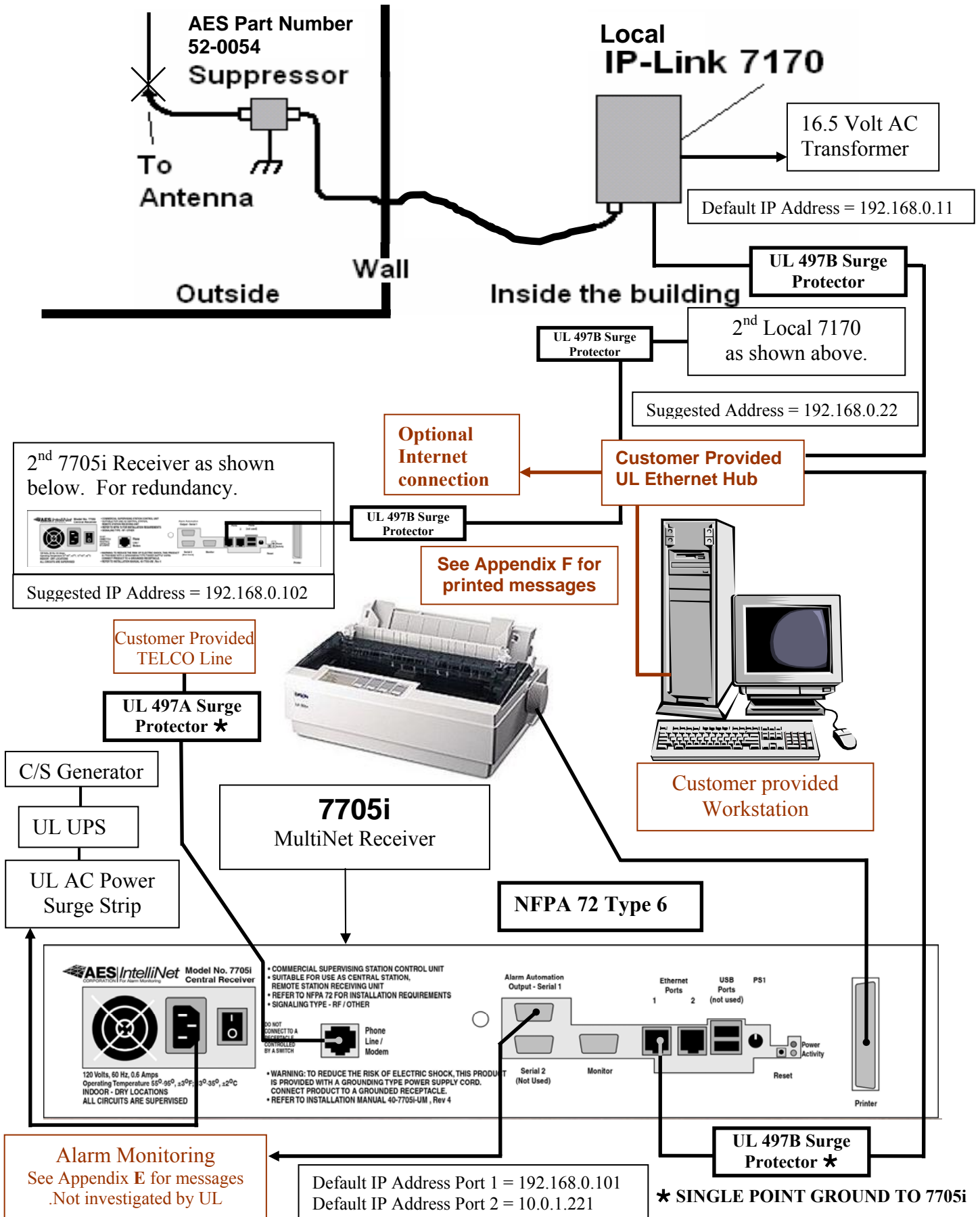
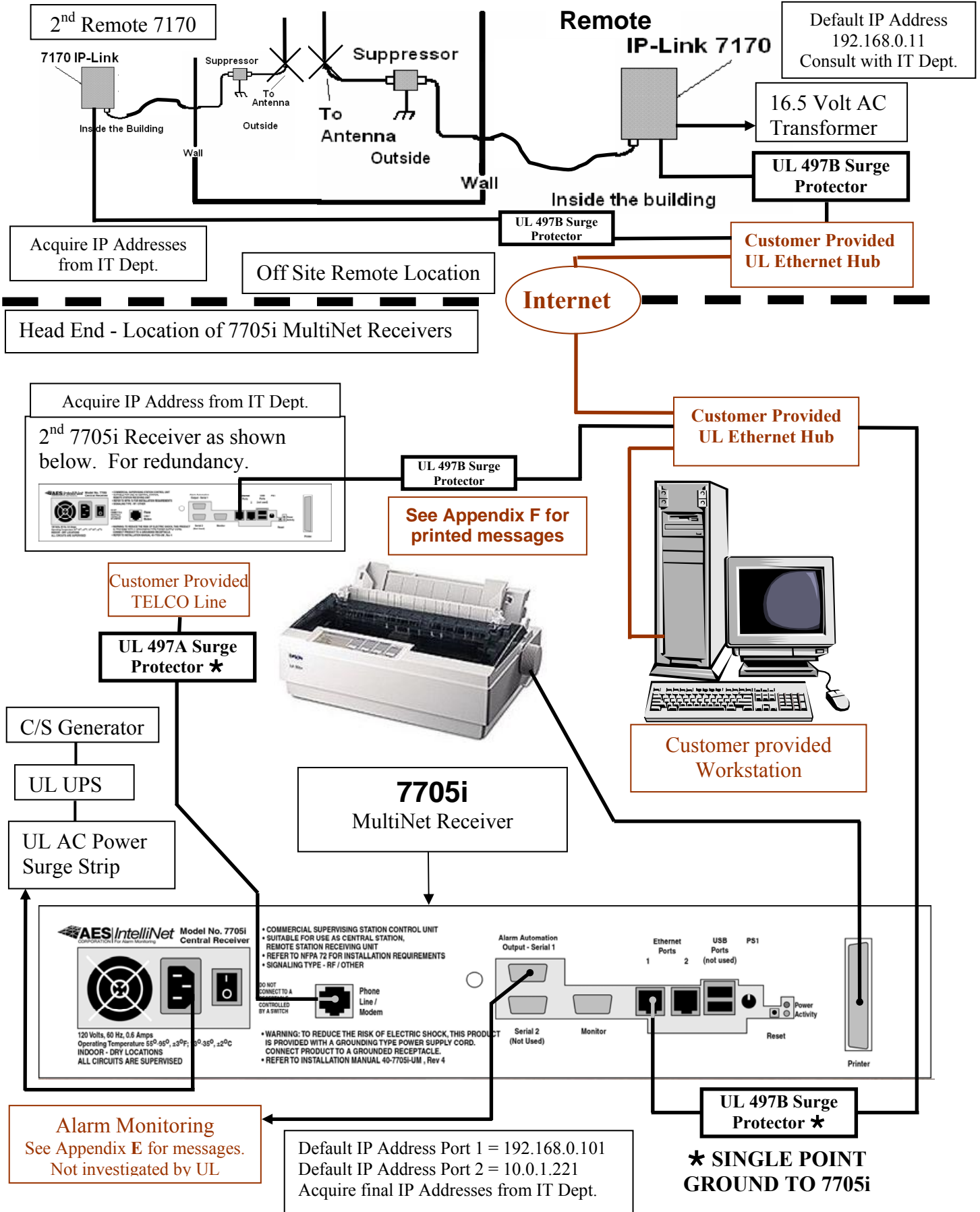


Figure 4-3

Dual MultiNet Receiver Connections to Remote 7170 IP-Links thru Internet



## 5.0 System Startup and Access:

AES ships the 7705i MultiNet Receiver with the Linux operating system and IP-Link programs pre-installed and with basic configuration already complete to operate as shown in [Figure 4-1](#). Each installation will have site-specific parameters that would typically be changed or entered during initial installation and setup.

**Refer to separate guide for assistance with initial setup.**

Familiarity with the Linux operating system will be necessary to run programs that operate, control and configure your IP-Link system. Refer to [Appendix A](#) for a list of some common Linux commands you might use in this process.

### 5.1 1<sup>st</sup> Time Notes:

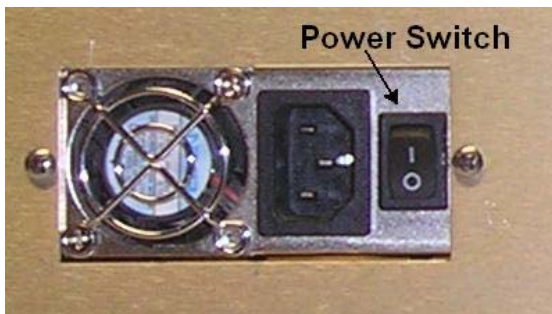
The first time that the MultiNet Receiver is powered up, it will require some configuration specific to the unique installation environment in which it is to be used. A directly attached keyboard, monitor and mouse will be needed to perform this configuration. Refer to separate Initial Installation and Setup Guide. Do not connect the Ethernet ports to an active network until you are confident the TCP/IP settings are appropriate for the target network.

### 5.2 Power up:

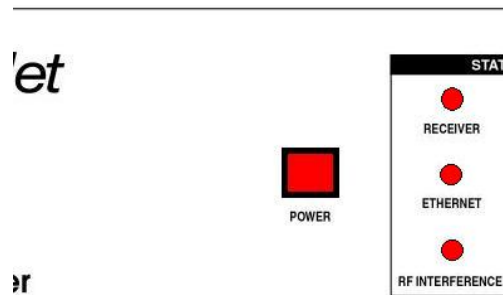
If this is a standalone system, or if you are still configured for initial setup as shown on [Figure 4-1](#) with an attached keyboard, monitor and mouse, turn on power of the attached video monitor.

Switch the power of the 7705i to the on position. The main switch for the power supply is on the back panel. This must be switched to on first. Then if the startup process does not automatically begin, push the Power push button Switch on the front panel to initiate the startup process.

Once the startup process has begun, the 7705i MultiNet Receiver will initialize, going through its normal boot sequence executing the programs defined in the configuration files. Password protected remote access through VNC is factory configured. Web access to the Admin GUI, which is an html-based interface, should be available after a proper startup, assuming the network settings are properly configured for the receiver's attached network.



Section of Rear Panel of Receiver



Section of Front Panel of Receiver

### 5.3 Power Down - Information:

The power to the 7705i should not just be removed without going through the proper shut down procedure.

**DO NOT REMOVE POWER OR TURN OFF POWER of the 7705i MultiNet Receiver WITHOUT USING THE PROPER SHUT DOWN PROCEDURE!**

This receiver is a Linux server and improper shut down could damage files and prevent operation. There are several ways to shut down a Linux server. Linux provides a command named “shutdown ” to perform this function.

- To shut down a MultiNet receiver, enter the following command from a command line prompt:

**shutdown -h now<Enter>**                      **Or**

- To shut down a MultiNet receiver from the GUI, right click on the desktop and select “Shutdown Server!”



### 5.4 Local Access and Login: - Initial Setup

Local access means to operate the MultiNet Receiver using a keyboard, monitor and mouse that are connected directly to the back of the Receiver. Login is required to operate the Receiver in this manner.

After a successful power-up, you should be presented with the login prompt “aes login:” You may have to press <Enter> after the boot up process to get the actual login prompt. Note the lines at the top of the display in [Figure 5-1](#). They are typically the last lines seen before the login prompt on the display for a normal boot up. Press <Enter> after these lines are displayed if the “aes login” is not displayed. For Super user Administrator functions you need to login as **root** using the current password. The factory default password for user **root** is **peabody2**.

- At the “aes login” prompt, type **root<Enter>** then **peabody2<Enter>**.

Note: After initial setup, if the password has been changed, as it should be, use the current password for user **root** to login to perform setup and configuration functions.

- **Be sure to log out when finished. See “[User Logout](#)”**
- **The user root is the most powerful Super user in a Linux server. Do not leave the system unattended when logged in as root!**
- **User root should only be used to perform administrative functions!**
- **To prevent unauthorized access – change default passwords as described in “[Managing Users](#)”, [section 9](#).**

When the startup and login process is complete, you should be presented with the command prompt “[root@aes root]#”. See [Figure 5-1](#) below. Enter key may need to be pressed before the prompt is actually displayed.

```
ipctrl for orphan is running
aesmon is running

Red Hat Linux release 7.3 (Valhalla)
Kernel 2.4.18-3 on an i686

aes login: root
Password:
Last login: (Date time stamp) on tty1

[root@aes root]# _
```

*Figure 5-1 Command Line Screen*

If your system's configuration is a dual UL or a non-UL system that is configured for remote access only, then your installation most likely does not or will not have a directly attached keyboard, monitor or mouse. Connect to the 7705i using VNC Viewer or your workstation program as instructed by the person or persons responsible for your configuration. See "[Workstation Access and Login:](#)"

## 5.5 Linux Command line:

After a successful local access login, you would normally be presented with a Linux Command line prompt. If you are using the Desktop GUI interface, as would be the case from a remote access session, and want to enter Linux commands from a command line prompt, then you will need to start a Terminal shell. Refer to [section 5.8](#) for information on starting the Terminal program. An example of the Terminal screen is shown in [Figure 5-3](#).

## 5.6 Common Linux Commands:

Refer to [Appendix A](#) for a list of some of the more common Linux commands you may be using with the Linux operating system installed on your MultiNet Receiver.

There is also an abundance of information on the subject of Linux Commands, available on the Internet to supplement any documentation you may already have. You could begin by searching for "Linux commands" using any of the common search engines or services.

Use extreme caution when attempting to use any Linux command on your MultiNet system as the consequences could have unexpected results, disrupt normal system operation or cause permanent possibly irreparable damage.

## 5.7 The GUI Desktop and the AES Menu:

**Note:** Access to this menu must be password protected for supervisors control only.



The Linux GUI Desktop used in the AES MultiNet Receiver is the Motif Window Manager (MWM). It is configured as a blue screen with no icons. The normal mouse cursor is a white trimmed black “X”. If you loose or unintentionally close the MWM, you can restart it by typing the following command at a command prompt:

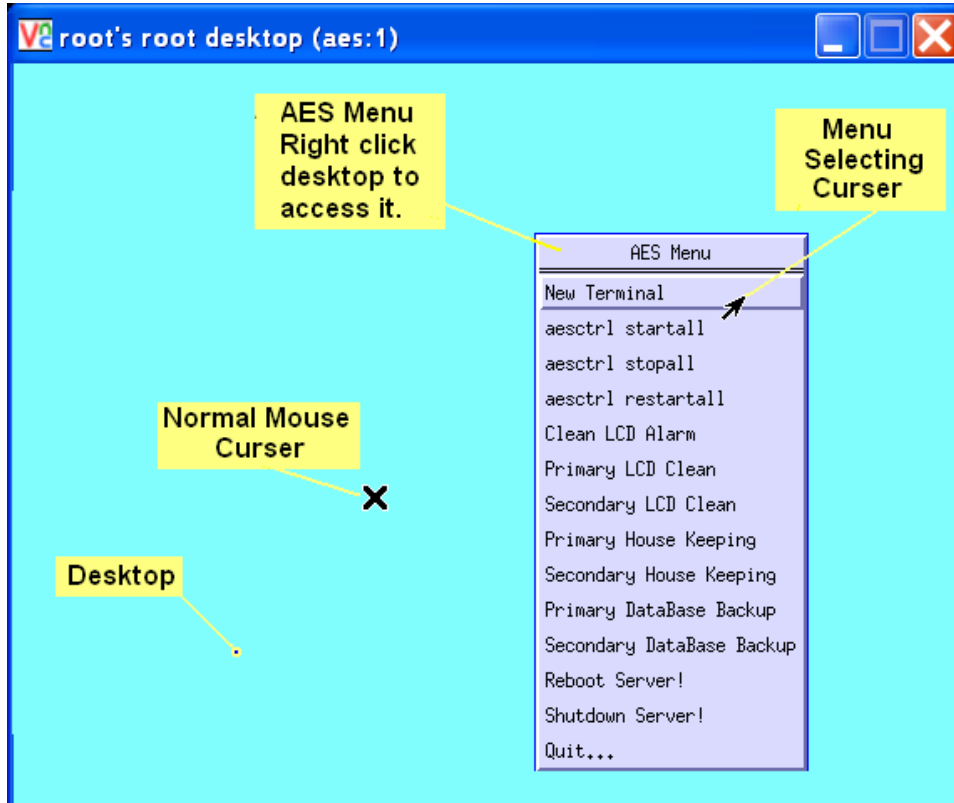
**startx<Enter>**.

If you connect using VNC Viewer access, this is the interface you will be presented with after a successful connection.

To access a menu of functions, right click on the desktop and hold. While holding the right click, move the cursor, which is now an arrow, over the menu items. Individual menu items will highlight as the cursor passes over. To select an item either release the right click while the desired menu item is highlighted or left click on the item while still holding the right click.

From the GUI Desktop, you will be able to start programs used to perform configuration, maintenance and other user functions.

An example of the desktop screen with a few comments added follows. The figure illustrates a false view as the  and  mouse cursers are both shown and it is not to an actual scale. The menu available from the right click is also shown. This view is also a representation of what the screen would look like if you were to access it using VNC Viewer as your workstation program.

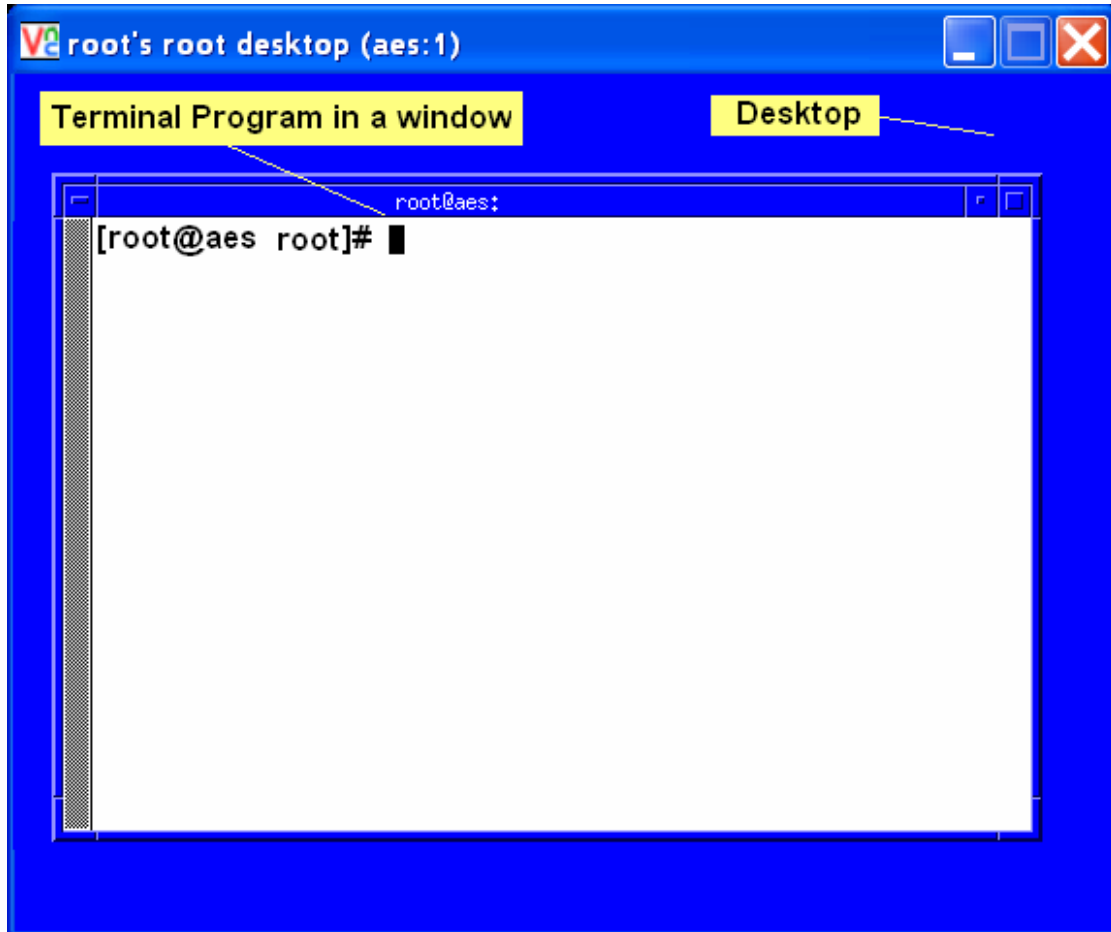


*Figure 5-2 GUI Desktop*

## 5.8 Start the Terminal Program:

Some of the utilities needed to configure the MultiNet receiver are accessed from a command line. A terminal emulator program named xterm is an offered selection from the AES menu available by use of the right click on the desktop. The terminal program provides a command line, which can be used to run utilities mentioned above.

Start the terminal emulator by selecting the “New Terminal” item in the AES Menu. The terminal window in the GUI desktop screen is shown below in [Figure 5-3](#). This is also a view using VNC Viewer from a remote PC that has access to the MultiNet receiver.



*Figure 5-3 Terminal window on the MWM Desktop*

## 5.9 Setting Time:

Time is very important and somewhat complex in a MultiNet System. Use the Linux date command to set the time as shown in one of the following examples:

Where    hh = hour                      mm = minutes                      .ss = seconds  
          MM = month                    DD = day                            CCYY = 4 digit year

**date MMDDhhmm.ss<Enter>**

**date MMDDhhmmCCYY.ss<Enter>**

**date 10031055.00**                      Sets the time to Oct 3, 10:55:00 AM using current year

For additional information on the date command, use:

**man date<Enter>**

Press Q to exit man program.

## 5.10 Synchronizing Time:

Contact AES Technical Support for options to synchronize two or more MultiNet Receivers to the same time standard. This is important in any system where servers share files.

## 5.11 Time Zone:

Time zone is also very important as time is kept internally in UTC and is set or displayed according to a variable that identifies the Time Zone the MultiNet receiver is located within.

By default, a MultiNet Receiver is typically set to Eastern Time Zone or America/New\_York.

The Setup program accessed by entering the setup command shown below on a command prompt is the easiest utility to use for setting the time zone.

**Setup<Enter>**

You can also use the following utility, but Setup described above is usually easier. Enter the following command to use the Time Zone Select utility:

**tzselect<Enter>** command to set the time zone. Follow instructions and answer the questions presented on the screen.

Contact AES Technical Support for additional information on adjusting the Time Zone on your MultiNet receiver.



## 5.12 Review your TCP/IP Configuration:

The TCP/IP parameters of all TCP/IP devices must be properly configured in order for the MultiNet Receiver to communicate with any local or remote IP-Link Transceiver(s), and any other TCP/IP devices it needs to communicate with.

As stated before, if you are connected as shown in [Figure 4-1](#) using the 7170 that was shipped with your receiver, then no configuration is needed for the pair to be operational.

There are two Ethernet adapters incorporated into the MultiNet Receiver. One is identified as **eth0** the other as **eth1**. You can issue the Linux command **ifconfig** at a command prompt to review the TCP/IP settings. It is best to request IP information one adapter at a time. Enter the following to view Port 1 settings:  
**ifconfig eth0<Enter>**

Review the data on the screen. Then, to review the settings of Port 2, the second adapter, enter the following:  
**ifconfig eth1<Enter>**

You can scroll the screen display to view information that has scrolled off by using the <Pg Up> and <Pg Dn> keys.

## 5.13 Factory Default TCP/IP Settings

The table below shows the factory default settings of all TCP/IP devices in a MultiNet Receiver / 7170 IP-Link transceiver pair. Both Receivers and IP-Link Transceivers in a dual system are configured the same from the factory. You **MUST** modify the TCP/IP settings of the second Receiver and IP-Link Transceiver before the two can be connected together in the same network. If the new MultiNet system is being placed in a network that has existing MultiNet devices then these new devices need unique settings.

Failure to do so will result in conflicts.

7705i Default Ethernet Port Settings		
Parameter	Ethernet Port 1 / eth0	Ethernet Port 2 / eth1
ONBOOT	Yes	Yes
BOOTPROTO	STATIC	STATIC
IPADDR	192.168.0.101	10.0.1.221
NETMASK	255.255.255.0	255.255.255.0
GATEWAY	192.168.0.1	10.0.1.7
7170 IP-Link Transceiver Default Ethernet Port Settings		
IP Address	192.168.0.11	
GATEWAY	192.168.0.1	
NETMASK	255.255.255.0	

*Table 5-4 Factory default TCP/IP settings*

## 5.14 Suggested TCP/IP Settings for Second MultiNet Receiver

The table below shows some suggested settings for the TCP/IP devices in the second MultiNet Receiver / 7170 IP-Link Transceiver pair of a dual system. These suggestions should be appropriate for a network that is only made up of devices from a MultiNet System. If you are connecting to an existing network you must get these values from the administrator of that network. Failure to get the proper values could prevent proper operation of the MultiNet devices or other existing devices on the network.

Second 7705i/ Suggested Ethernet Port Settings		
Parameter	Ethernet Port 1 / eth0	Ethernet Port 2 / eth1
ONBOOT	Yes	Yes
BOOTPROTO	STATIC	STATIC
IPADDR	192.168.0.102	No Suggestion
NETMASK	255.255.255.0	255.255.255.0
GATEWAY	192.168.0.1	10.0.1.1
Second 7170 IP-Link Transceiver Suggested Ethernet Port Settings		
IP Address	192.168.0.22	
GATEWAY	192.168.0.1	
NETMASK	255.255.255.0	

*Table 5-5 Suggested TCP/IP Settings for Second Receiver & 7170*

## 5.15 A note on DHCP

DHCP is an acronym for Dynamic Host Configuration Protocol. This means IP addresses are automatically assigned by a DHCP server on your network. Since the MultiNet Receiver's in a MultiNet system must have a unique static IP addresses, a DHCP server would have to be configured to reserve and always provide the same address to each specific receiver. Contact your IT department for additional information. Do not use this option if you do not have a DHCP server on your network, or cannot configure it to provide static addresses to specific devices.

## 5.16 Configure TCP/IP, Linux Network Configuration:

As mentioned before, there are two Ethernet ports in the MultiNet receiver. The port names are Ethernet Port 1 [eth0] and Ethernet Port 2 [eth1]. If you are using both ports, you will need to enter the commands to configure each port separately.

Note that physical Ethernet connector labeled Port 1 is internally identified as eth0 and that the Ethernet connector labeled Port 2 is internally identified as eth1. This is due to a typical convention where components such as connectors are numbered beginning at 1 and a programmers' convention that usually begin at 0.

In a Linux environment there are usually several ways to accomplish the editing of parameters and similar tasks. Following are instructions for using programs or scripts provided by AES for the purpose of setting up the TCP/IP parameters of each port. A script provided by AES for configuring these parameters is initiated by entering either the command `“./editnetworketh0”` or `“./editnetworketh1”` from a command line prompt.

You will be instructed when to enter the above command, for now, read on.

The script will first run some preparation commands then start the KWrite Linux text editor and open the appropriate configuration file. This opened file is a text file that must contain the proper lines of configuration information while maintaining the original format. After you save and close the editor the script will continue by initiating and testing the new configuration. Watch the left side of the screen for messages such as [ OK ] or [ Fail ] indicating success or failure of those tests.

**Note:** AES ships the 7705i, pre-configured to operate as shown in [Figure 4-1](#) as a single receiver. This is to assist those who want a quick setup to be able to perform radio testing and to become familiar with the system prior to a permanent installation into your operational alarm monitoring system. Later or if your intended initial installation will be connected to a LAN, WAN, you will have to change the TCP/IP parameters as described on the following pages to operate with your LAN/WAN and Internet network environments.

Contact your IT department for assistance with these parameters.

For a simple installation where a crossover Ethernet cable is used to connect the 7170 IP-Link Transceiver directly to Ethernet Port 1 (J10), eth0 of a single or the first 7705i MultiNet Receiver, the following settings in this receiver along with the recommended settings in the 7170 manual should allow communication:

See [Figure 4-1](#).  
IPADDR=192.168.0.101  
NETMASK=255.255.255.0  
GATEWAY=192.168.0.1

Perform the settings on Ethernet Ports 1 [eth0] & 2 [eth1].

**IP address:** Unique IP address to be assigned to this MultiNet Receiver.

**Netmask:** Netmask for the connected network.

**Default gateway (IP):** Gateway address for the connected network.

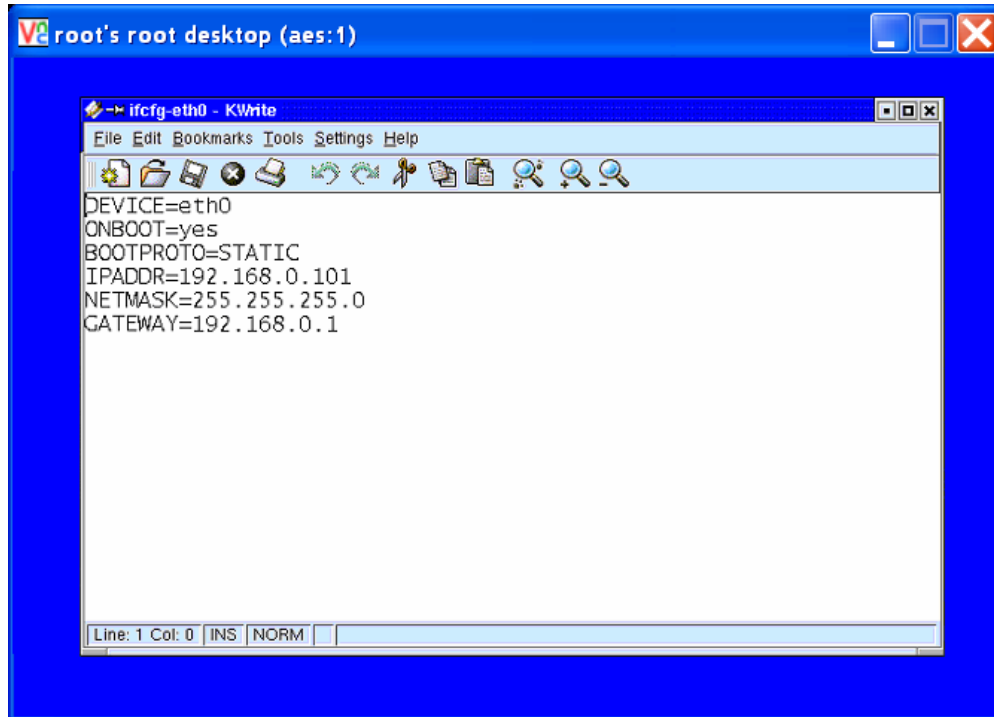
**Primary nameserver:** Nameserver for the connected network.

- **Use caution, as incorrect settings could disable the system, especially if it were already configured.**
- **Previous settings are shown in the fields when the configuration files are opened. Once edited and saved you could lose those values if you have not recorded them elsewhere.**

In the xterm terminal window, enter the following command to initiate the script to modify the configuration of Ethernet port 1 (eth0).

**./editnetworketh0<Enter>**

Don't forget to first type the dot and forward slash “./”. The following window for the KWrite text editor with the configuration file for Port 1 should appear. Use caution as incorrect settings could disable the system, especially if it were already configured.



**Figure 5-5 KWrite Text Editor with file ifcfg-eth0 Open**

There are usually about 6 lines of parameters in the configuration file. Only edit the lines described below to provide the parameters needed for your installation. Do not edit the parameter name or add spaces. You only need to edit or confirm the following lines: (order not important)

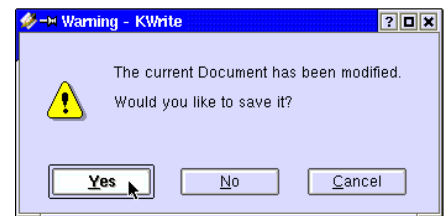
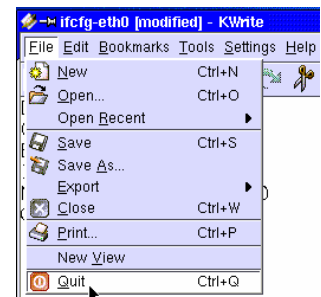
ONBOOT=yes

IPADDR={IP address for this MultiNet Receivers port}

NETMASK={Net mask for the attached network}

GATEWAY={Gateway for the attached network}

Once you have modified the lines to your desired settings, select “Quit” in the File menu. If the editor detects that you made changes, you will be asked to save the current Document. Click [Yes]. Click [No] if you are unsure of your edits and want to begin again.



Once the editor is closed the script will continue by initializing the new settings and running a few tests. Watch the screen for errors.

## 5.17 Testing TCP/IP Configuration:

Before you can test the TCP/IP configuration you need to make the connection of the Ethernet Port(s) to the target network.

Once TCP/IP setup is complete and the Ethernet cables are connected to an operational network, perform the following test to determine if your MultiNet Receiver is working properly in the network. To test your settings, ping another computer or device that is on your network. At a command prompt, issue the following command replacing {network ID of another computer} with the IP address of the gateway or other known PC on the network.

**ping -c4** {network ID of another computer} <Enter>

Example: ping -c4 192.168.0.1 <Enter> (Default Gateway PC)

or ping -c4 192.168.0.11 <Enter> (Default 7170 setting)

The above listed ping commands will ping 4 times (-c4), either the default Gateway, or the 7170 assuming they are configured as listed.

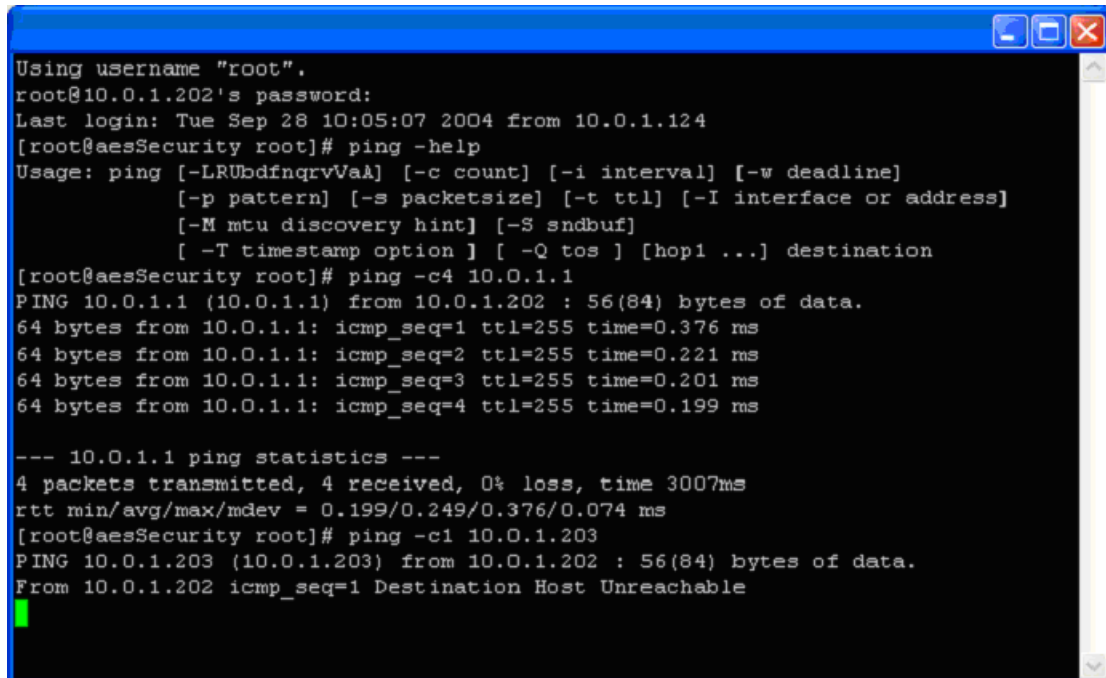
You can even ping the IP address of the receiver itself to see how the ping program works. **Ping -c4 192.168.0.101** <Enter> (Default Receiver)

If necessary you may press:

<Ctrl> + C to stop pinging attempts.

You should receive responses indicating how long the response took, if it failed or timed out.

The example screen below shows the “ping -help” response, a successful ping and a failed ping.



```
Using username "root".
root@10.0.1.202's password:
Last login: Tue Sep 28 10:05:07 2004 from 10.0.1.124
[root@aesSecurity root]# ping -help
Usage: ping [-LRUbdnqrVvAA] [-c count] [-i interval] [-w deadline]
          [-p pattern] [-s packetsize] [-t ttl] [-I interface or address]
          [-M mtu discovery hint] [-S sndbuf]
          [-T timestamp option ] [ -Q tos ] [hop1 ...] destination
[root@aesSecurity root]# ping -c4 10.0.1.1
PING 10.0.1.1 (10.0.1.1) from 10.0.1.202 : 56(84) bytes of data.
64 bytes from 10.0.1.1: icmp_seq=1 ttl=255 time=0.376 ms
64 bytes from 10.0.1.1: icmp_seq=2 ttl=255 time=0.221 ms
64 bytes from 10.0.1.1: icmp_seq=3 ttl=255 time=0.201 ms
64 bytes from 10.0.1.1: icmp_seq=4 ttl=255 time=0.199 ms

--- 10.0.1.1 ping statistics ---
4 packets transmitted, 4 received, 0% loss, time 3007ms
rtt min/avg/max/mdev = 0.199/0.249/0.376/0.074 ms
[root@aesSecurity root]# ping -c1 10.0.1.203
PING 10.0.1.203 (10.0.1.203) from 10.0.1.202 : 56(84) bytes of data.
From 10.0.1.202 icmp_seq=1 Destination Host Unreachable
```

*Figure 5-6 Example of a ping to a gateway PC*


## 5.18 User Logout from directly attached keyboard & monitor:

You should log out the user that is logged in (usually root), when local access using the directly attached keyboard, monitor and mouse, to your system is no longer need. Depending on where you are and what you are doing the procedure will vary. Several options are outlined below.

### Option 1: Logout (preferred method)

With this option you will log out and go back to the aes login screen.

1. If you are at a command line prompt and not running the MWM GUI, then go to step 3.
2. If you are in the MWM GUI, first select Quit... from the AES Menu. Confirm by clicking OK or press <Enter>.

Select Quit... Menu item → 

Then click OK or press <Enter>

3. Enter one the following commands at the command prompt:  
**logout<Enter>**      or      **exit<Enter>**




4. The screen should return to the aes login prompt.

### Option 2: Reboot server

1. The system will accomplish a logout when you reboot the MultiNet receiver. This will restart the server stopping at the aes login screen. Be careful if you are rebooting an active MultiNet Receiver as signals may be processing and a reboot could delay or terminate that process. Other users may also be connected and this will disconnect them possibly interrupting their work or cause loss of data.

To reboot do one of the following:

- a. From the command line prompt enter the following:  
**reboot<Enter>**
- b. From the MWM GUI, select the "Reboot Server!" item in the AES Menu accessed by right clicking on the MWM desktop

Select Reboot Server! Menu item → 

2. This process should leave a properly configured MultiNet receiver and its programs running allowing remote access by the super user root via VNC on display 1, as well as any other users that were properly created.

## 5.19 User Logout from Workstation Access:

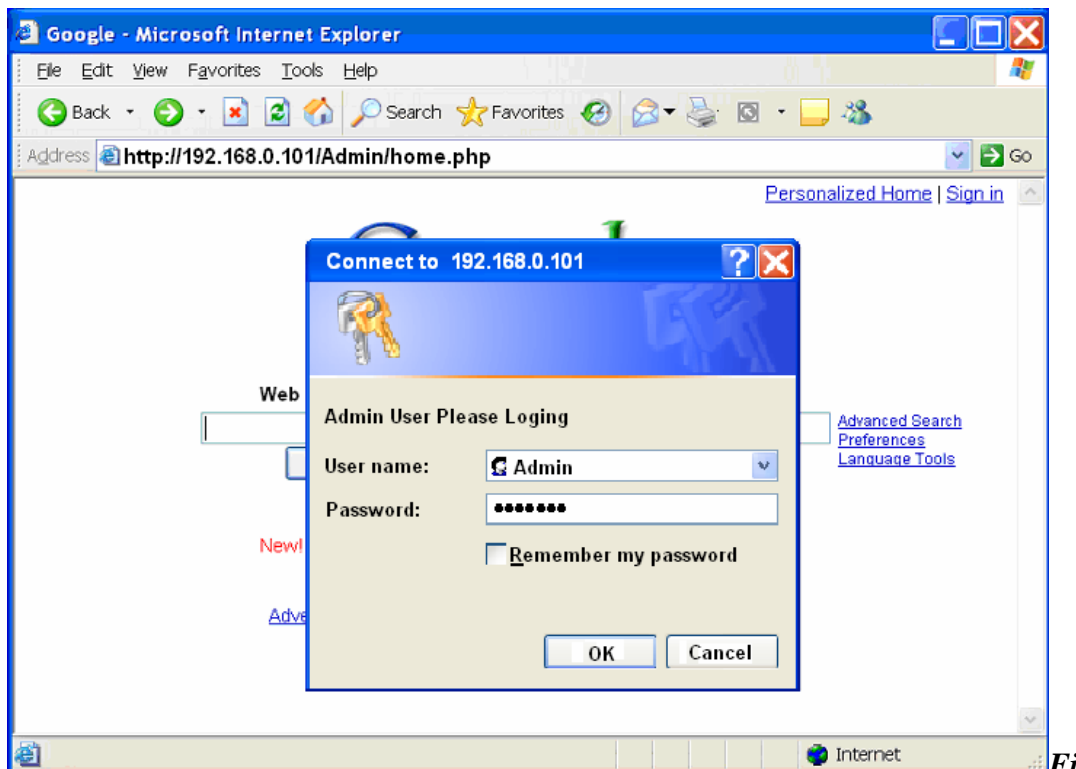
If you need or want to logout from the workstation access session, simply close the program you are using to establish that access. For example: If using VNC Viewer, close the program by clicking on the X in the upper right corner of the VNC window. The password will be required the next time you attempt access.

## 6.0 Admin GUI for Configuration and Administration:

The Admin GUI is a set of files located in a directory linked to “Admin” under the Apache “htdocs” directory. To access this Admin GUI you need to connect using a Web Browser from a network workstation. The Apache Web Server running on the MultiNet receiver protects this connection with 128 Bit SSL Encryption. Some possible URL’s used to access the GUI are:

http://192.168.0.101/Admin/home.php Using workstation to receiver 1 eth0  
http://localhost/Admin/home.php Using attached keyboard/monitor.

To get access to the Admin GUI simply use a Web browser and enter the URL as indicated above. Your actual URL may be different and will be the actual IP address assigned to each MultiNet receiver in earlier steps.



*Figure 6-1 Remote Login to Admin GUI*

The correct URL takes you to the login window as seen above,

The correct username and password takes you to the main menu page (homepage) of the Admin GUI.

To change the username and password see [Change Admin GUI Access](#) under the [Managing Users, Section 9](#).

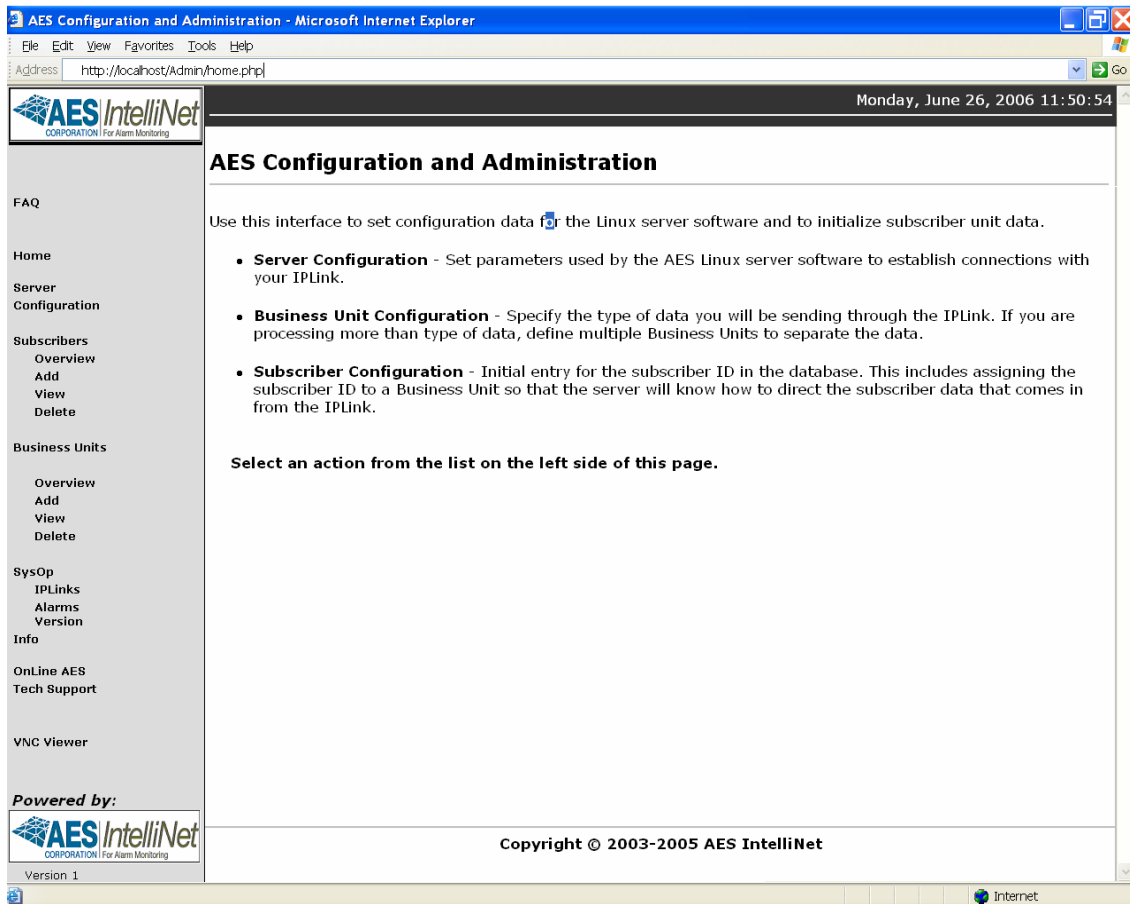
Factory default username = **Admin**

Factory default password = **peabody**

**Note:** If you check the “Remember my password” box, you will not have to enter your password on future attempts from this same workstation, after a successful login. This will significantly reduce security, as anyone who gets access to the workstation may be able to modify your MultiNet Receiver Server settings.

Once you get to the Admin GUI Homepage, there is a brief overview of the functions available through the GUI. There are links in the left hand column of this page and every page that can be used to select actions.

Below is a sample screen from the Admin GUI. The following sections describe the functions of the Administration program.



*Figure 6-2 Admin GUI program home screen*



## 6.1 Server Configuration

Among the first parameters that must be configured are on the Server Configuration page. AES ships the receivers pre-configured as indicated throughout this manual. To review or edit the parameters, access the Admin GUI Server Configuration screen as indicated above and click on "Server Configuration" on the left hand side of the screen. This brings you to the AES Server Configuration screen, where you modify as needed the following parameters:

The screenshot shows the AES Server Configuration web interface. The browser window title is "AES Server Configuration - Microsoft Internet Explorer". The address bar shows "http://10.0.1.242/admin/sys1.php". The page header includes the AES IntelliNet logo and the date "26, 2006 13:30:33". The main content area is titled "AES Server Configuration" and contains the instruction "Enter parameters that control operation of the Linux server software." Below this are several configuration fields: "Server ID Number" (0001), "Server Receiver Number" (1), "IPLink Port Number" (7070), "Modem Device Path" (/dev/ttyS3), "LCD Path" (/dev/ttyS2), and "Verbose" (Full). A "Set Configuration" button is located below the fields. A left sidebar contains navigation links for Home, Server Configuration, Subscribers, Business Units, SysOp, Info, OnLine AES, and VNC Viewer. The footer includes the AES IntelliNet logo and "Version 1".

*Figure 6-3 AES Server Configuration Screen*

- **Server ID Number:** Identification number of your MultiNet Receiver (server). Unless you are running more than one server at your site, we recommend using the default value of 0001. Use 0002 for the second. Each needs a unique ID. Range is decimal 0001 to 9999.
- **IP-Link Port Number:** Port used by your IP-Link Transceiver(s) to connect to the server. Default and suggested value is 7070.
- **Modem Device Path:** Unix path used by the modem in your IP-Link Transceiver. Default is "/dev/ttyS3". Unless you are very well versed in Linux and the hardware of this receiver, do not enter anything else here unless directed by AES Technical or Engineering Support.
- **LCD Device Path:** Unix path used by the LCD in your IP-Link Transceiver. Default is "/dev/ttyS2".

- **Verbose:** Controls the amount of information written to limited size log files. A pull down menu allows you to set this parameter to Off, On or Full. In most cases, the Off setting should be used, so that only critical messages are written to the log files. If more information about system operation is required, the On setting can be used. The Full setting should only be used at the direction of AES support personnel. This is an “Event” log. The more information stored on each event reduces the total number of events stored in the log.
- **Set Configuration:** When complete, Click the [Set Configuration] button to save the configuration. If you have not already created at least one Business Unit, you will be asked to do so before leaving the Server Configuration screen.

## 6.2 Define Business Units: (you must have at least one)

Each subscriber unit’s application data type must be associated with a Business Unit. Business Units are defined based on the types of application data they process. Each Subscriber must be associated with the proper type Business Unit to handle the data packets produced by the Subscribers. Since every Subscriber creates at the very least, Check-In, Status and other routine messages, most Business Units have settings for Alarm data and may have to be linked with the Business unit of Data Type: Security, if those messages are to be monitored by an alarm monitoring system. Each user that will have remote access would have a Business Unit set up for their exclusive use.

To provide for site-specific particulars, there are no user Business Units pre-configured in the MultiNet receiver from the factory. You need to create at least one to continue.

Select “Add” under “Business Units” in the left side of the window.

If this is your First Business Unit, select this? You can change it later if necessary.

Do not select this checkbox if this is an additional Business Unit that will use the Serial Port already configured for use by another Business Unit.

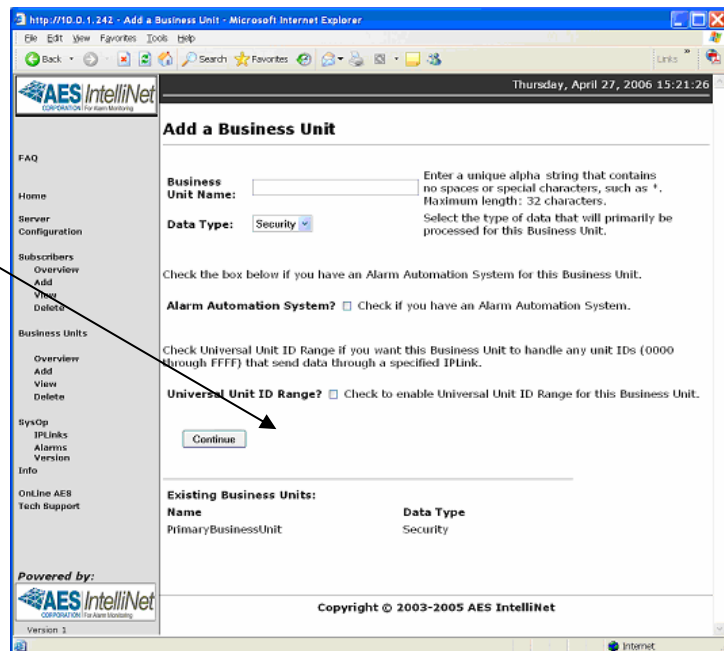


Figure 6-4 Add Business Unit Screen

Some systems will only have one type of application data and one access point, and thus will need to create only one Business Unit. If you have multiple types of data and need multiple remote access locations, define a Business Unit for each data type and or remote user. For example, if you have subscriber units that send GPS data, and subscriber units that send alarm data, you would need to define two Business Units. Business Units can also be used to separate elements of your operation; if you have networks that are independent, you may find it helpful to create separate Business Units for them.

The software uses the business unit name internally, to name Linux directories. It should be all alpha characters less than 32 in length and should not contain spaces or special characters such as an “\*” that are invalid for Linux directory names. Selecting a name that helps identify the purpose of the Business Unit helps with database management. You need to enter data into the following fields to create a Business Unit:

- **Business Unit Name:** An alphanumeric string you will use to refer to the Business Unit. The Business Unit Name is used internally by the software to name Linux directories. It should be less than 32 characters long and cannot contain spaces or characters that are invalid in Linux directory names, such as \*. Linux names are case-sensitive.
- **Data Type:** A pull down menu on the screen is used set the application data type for the Business Unit. Options include Security, Meter, USDI, GPS and Vending. Select the Subscriber data type for this Business Unit from the pull down menu.
  - Security – This data type will produce messages to be sent to a specific alarm monitoring system using a specific alarm output emulation. A different emulation, another monitoring system or other differences in the parameters will require a separate Business Unit. See [Appendix E](#) for a listing of generated messages.

**The data types listed below may not be selected per UL 864**

- USDI – This data type is expecting data from a USDI Subscriber. Also creates Alarm data.
- GPS – Do not select data type.
- Vending – Do not select data type.
- Pump – Do not select data type.



- **Alarm Automation System:** If you have an Alarm Automation or monitoring system, check the “Alarm Automation System” checkbox. You will be presented with a data entry screen to enter its parameters. See following pages for screen examples and data fields.

***NOTE!: If a Business Unit will utilize a serial port that has already been configured and assigned to another Business Unit, DO NOT SELECT THE “Alarm Automation System” CHECK BOX. You must follow Special Instructions included on following pages and a special procedure located in Appendix D at the end of this manual. Instructions in Appendix D will link the selected new Business Unit to the Business Unit that uses the Serial Port. Failure to properly comply with this requirement may prevent the additional Business Unit(s) from being able to use the Serial Port. An existing Business Unit can also be edited later to meet the requirements for linking to another Business Unit by replacing the fields with a blank entry.***

- **Universal Unit ID Range:** Check this if you will have only one Business Unit and want all Subscribers to be associated with this Business Unit even if you do not manually add them to a Subscriber Database.

If the Universal Unit ID Range check box is not checked you will need to manually add each new subscriber to a Subscriber Database assigned to a Business Unit. Any signals received from a Subscriber not in a database will force it to be handled by the pre-configured Business Unit named orphan.

If the Universal Unit ID Range check box is checked, any new subscriber not in a database that sends data would automatically use this Business Unit.

- **IP-Link ID:** Enter the ID of the IP-Link Transceiver that will handle all Subscribers when selecting Universal Unit ID range above.

Once you have entered data in all the required fields, click

Continue

If you have checked “Alarm Automation System?” you will see the screen shown on the next page. If you did not, this screen will be skipped.

## 6.3 Add a Business Unit – Alarm Automation Settings.

**Add a Business Unit - Alarm Automation Settings**

Creating Business Unit: *m* for Security data

You can connect to your Alarm Automation System through a serial port, or an IP socket, or both. Enter connection parameters below.

**Serial Port Parameters**

Serial Device Name:  Baud Rate:

Data Bits:  Parity:  Stop Bits:

Heartbeat Signal Frequency:  (seconds) Number of seconds between heartbeat signals, if your automation system sends them.

**IP Parameters**

IP Address:  Port Number:

Heartbeat Signal Frequency:  (seconds) Number of seconds between heartbeat signals, if your automation system sends them.

**Automation Message Format**

Automation Format:  Format of messages sent to your alarm automation system.

Receiver Number:  Receiver number setting in automation messages for this Business Unit.

**Automation Message Printing**

Print only when automation is down. All messages will be printed. (default)

Print alarms sent to automation.

Always print automation messages.

**Email Alarms**

You may specify an email address for alarm delivery. This is optional.

E-Mail Address:  (optional)

**Old Alarm Delivery**

Deliver all old alarms for this Business Unit. (default)

Individual Subscriber Unit settings control delivery of old alarms.

Never deliver old alarms for this Business Unit.

Copyright © 2003-2005 AES IntelliNet

Figure 6-5 Automation Settings

- **Alarm Automation System Settings:**
  - If the Check-In, Alarm, Status, Trouble and Restore messages produced by a subscriber unit will be monitored by an alarm automation system or monitoring software, you need to configure these parameters. Failure to do so may prevent vital messages like AC failure, Low battery and other faults from being reported. You must check the “Alarm Automation System?” checkbox. You will be presented with a data entry screen shown above. You can connect to the alarm monitoring system via serial connection and or TCP/IP connections. The following fields are available to edit.

## **WARNING! AVOID ERROR MESSAGES**

Be sure there is a functioning Alarm Automation system properly attached and in service on the configured port and or IP address, ready to receive signals immediately after the parameters are saved. Messages may be generated and any enabled heartbeat needs to get its proper responses.

Leave the Serial Device Name, Heartbeat Signal frequencies and IP Address blank, if you need to configure a security Business Unit to not produce error messages, due to no in service Alarm Automation System.

**Special Instructions:** If this is an additional Business Unit that will use a Serial Port that has already been assigned and configured, then a Blank entry MUST be used in the Serial Device Name and Heartbeat Signal Frequency fields. Instructions in [Appendix D](#) must be followed after completing this Business Unit, to link it to the Business Unit that has a configured serial port, before it will be able to utilize the Serial Port.

### o **Serial Port Parameters:**

- Serial Device Name: Enter the name of the serial device used for the serial port. Default value is: /dev/ttyS1 for COM1 (upper serial port). /dev/ttyS0 for COM2 is used internally and is not available.
- Com Parameters: Select the Baud Rate, Data Bits, Parity, and Stop Bits to use on the Serial for these alarm automation messages. Default values are 1200, 7, Odd and 2 Stop Bits. See [Appendix E](#) for a listing of generated messages.
- Heartbeat Signal Frequency: Enter the number of seconds between heartbeat signals on the serial port from Alarm Automation. The heartbeat is an upper case “S” when in Ademco 685 emulation. You should add a period of time as a window that the signal may be sent. Example: If your Alarm Automation sends an “S” every 20 seconds, you may want to set this parameter to 40. This allows the Alarm Automation an additional widows of 20 seconds and two attempts to send the heartbeat before a fault message is generated by the 7705i Receiver. This shall be configured by UL1981 Central-Station Automation Systems Requirements.
- Entering a value of 0 disables the feature and the 7705i will not be looking for the heartbeat. The MultiNet Receiver will not announce a fault due to no heartbeat being sent.

### o **IP Parameters:**

- IP Address: Enter the IP address of the Alarm Automation system. The default is blank and should only have an entry if there is to be communication to Alarm Automation via TCP/IP.
- Port Number: is the IP port that the 7705i send it alarm automation messages on. Default is blank.

- Heartbeat: Enter the number of seconds between heartbeat signals on the IP port from Alarm Automation. The heartbeat is an upper case “S” when in Ademco 685 emulation. You should add a period of time as a window that the signal may be sent. Example: If your Alarm Automation sends an “S” every 20 seconds, you may want to set this parameter to 40. This allows the Alarm Automation an additional widows of 20 seconds and two attempts to send the heartbeat before a fault message is generated by the 7705i Receiver. Default is 0 or disabled. This shall be configured by UL1981 Central-Station Automation Systems Requirements.
  - **Automation Message Format:**
    - Automation Format: Select the emulation to use for messages using these settings. Select either Ademco or Radionics according to the configuration of the alarm monitoring system. See [Appendix E](#) for a listing of generated messages.
    - Receiver Number: Select the number to place in the character(s) that represent the Receiver Number in the Alarm Automation message. Default is 1. Range is Blank, 0 to 9 and A to F. 0 and Blank are selectable options but may not be valid entries for all alarm Automation systems. Some Alarm Automation systems may ignore or be set to ignore this parameter.  
  
Unless you know you need or want something different, use the default and suggested value of 1.
  - **Automation Message Printing:**

This parameter controls how the MultiNet receiver prints alarm messages to its assigned printer.

Options are:

    - Print only when alarm automation is down. All messages will print but only those that cannot be reported to alarm automation.
    - Print alarms sent to automaton. This setting echoes successfully reported messages to the printer.
    - Always Print Automation Messages. This setting prints all messages regardless of state of alarm automation.
  - **Email Alarms:**
    - Optionally you can enter an email address to send alarm messages.
  - **Old Alarm Delivery:**

Old (or prior) alarms are reported by AES Subscribers when a zone that has gone into alarm in the past and has not yet restored to its non-alarm condition at the time the Subscriber is sending a Check-In or a Status report.

UL 864 requires a setting of:  
“Deliver all old alarms for this Business Unit.”

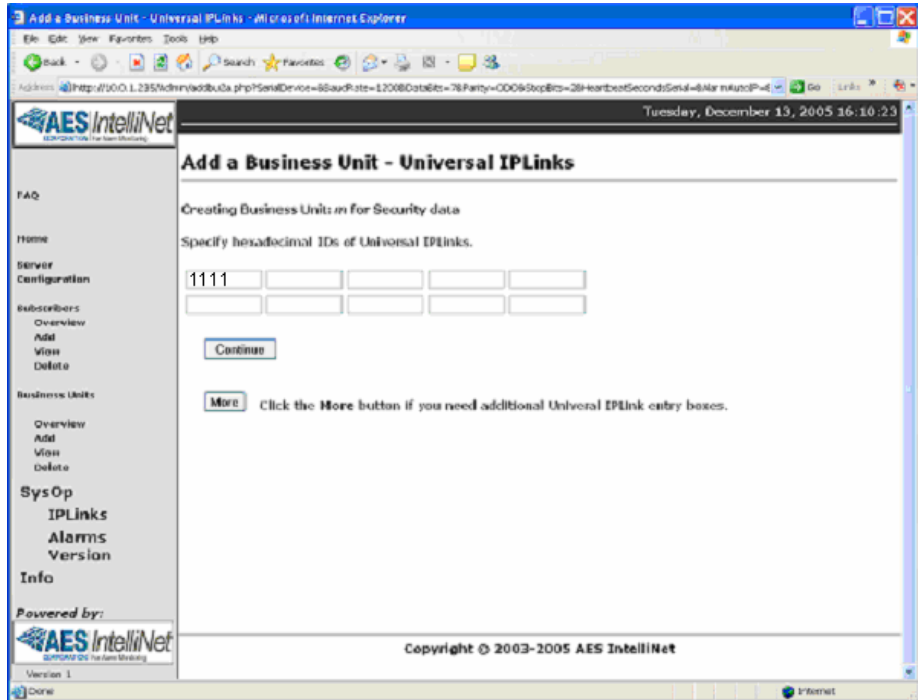
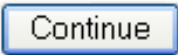


Some Alarm automation systems may not be configured to properly report these types of messages. You may have some other reason not to send these to automation but, be aware, these are important messages as they indicate zones that are possibly stuck, improperly configured, improperly wired or in an alarm condition and may not be able to report a new event.

Options are:

- Individual Subscriber Unit settings control delivery... , which is configured for each Subscriber in its configuration settings.
- Deliver all old alarms... , which will ignore Subscriber configuration and report all old alarms to automation.
- Never deliver old alarms... , which will ignore Subscriber configuration and not report all old alarms to automation.

Once you have entered data in all the required fields, click .  
If you selected Universal Unit ID Range, the following screen appears.



**Figure 6-6 Add a Business Unit – Universal IPLinks**

Enter the ID or IDs of the IP-Link Transceivers that will handle the Subscribers for this Business Unit.

When complete click...

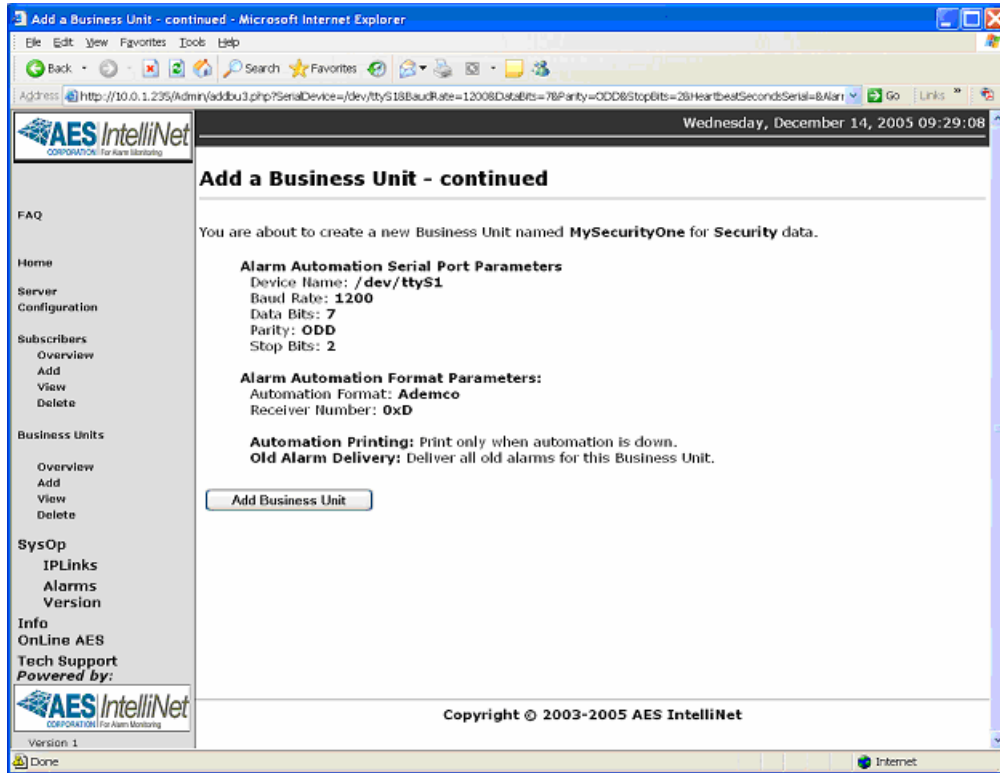


The following screen, or one similar if Alarm Automation System were not checked should be presented. After reviewing the information.

Click Add Business Unit to complete the process

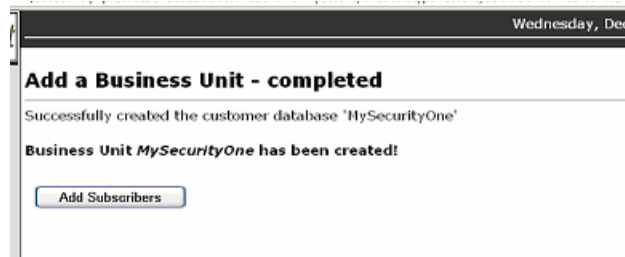






*Figure 6-7 Add a Business Unit - continued*

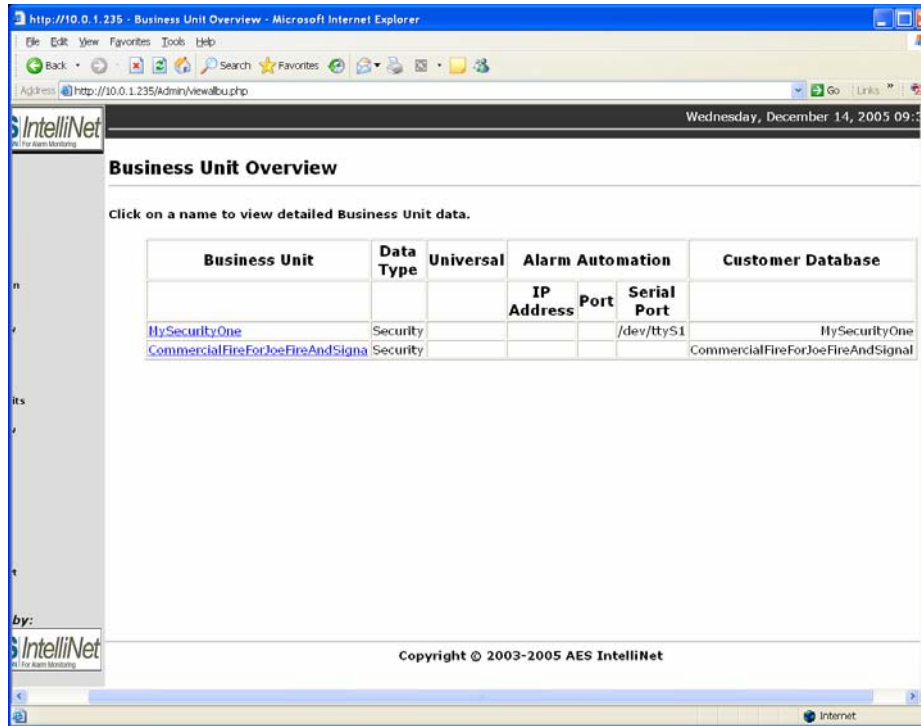
A partial view of the final screen indicating a successful add, is shown below.



*Figure 6-8 Add a Business Unit – completed*

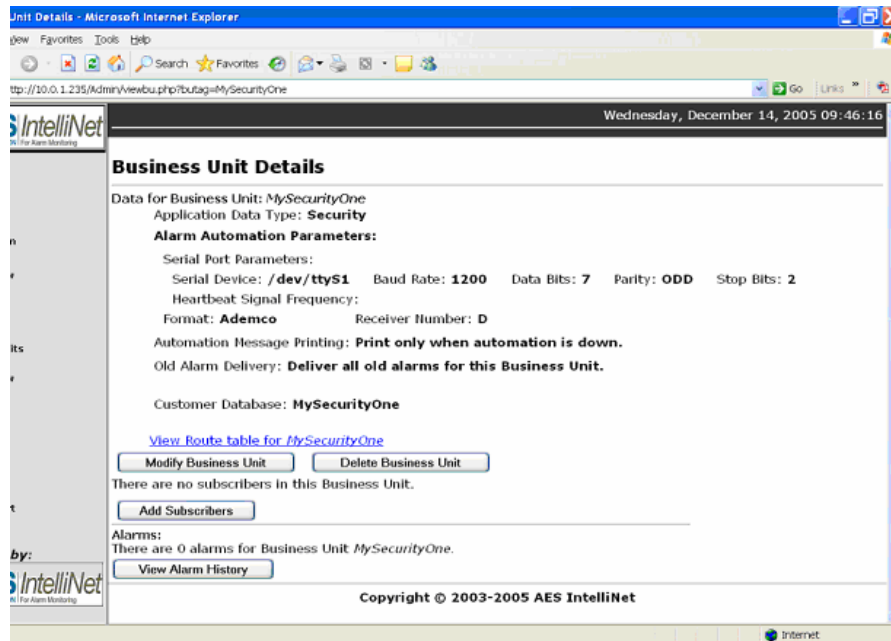
## 6.4 Business Unit Overview

Once you have created at least one Business Unit you can select Overview to view its information. Below is a sample partial screen that shows several Business Units. You can select an underlined link, to view details.




*Figure 6-9 Business Unit Overview*

Below is a sample compressed screen that shows the details for the underlined link [MySecurityOne](#).



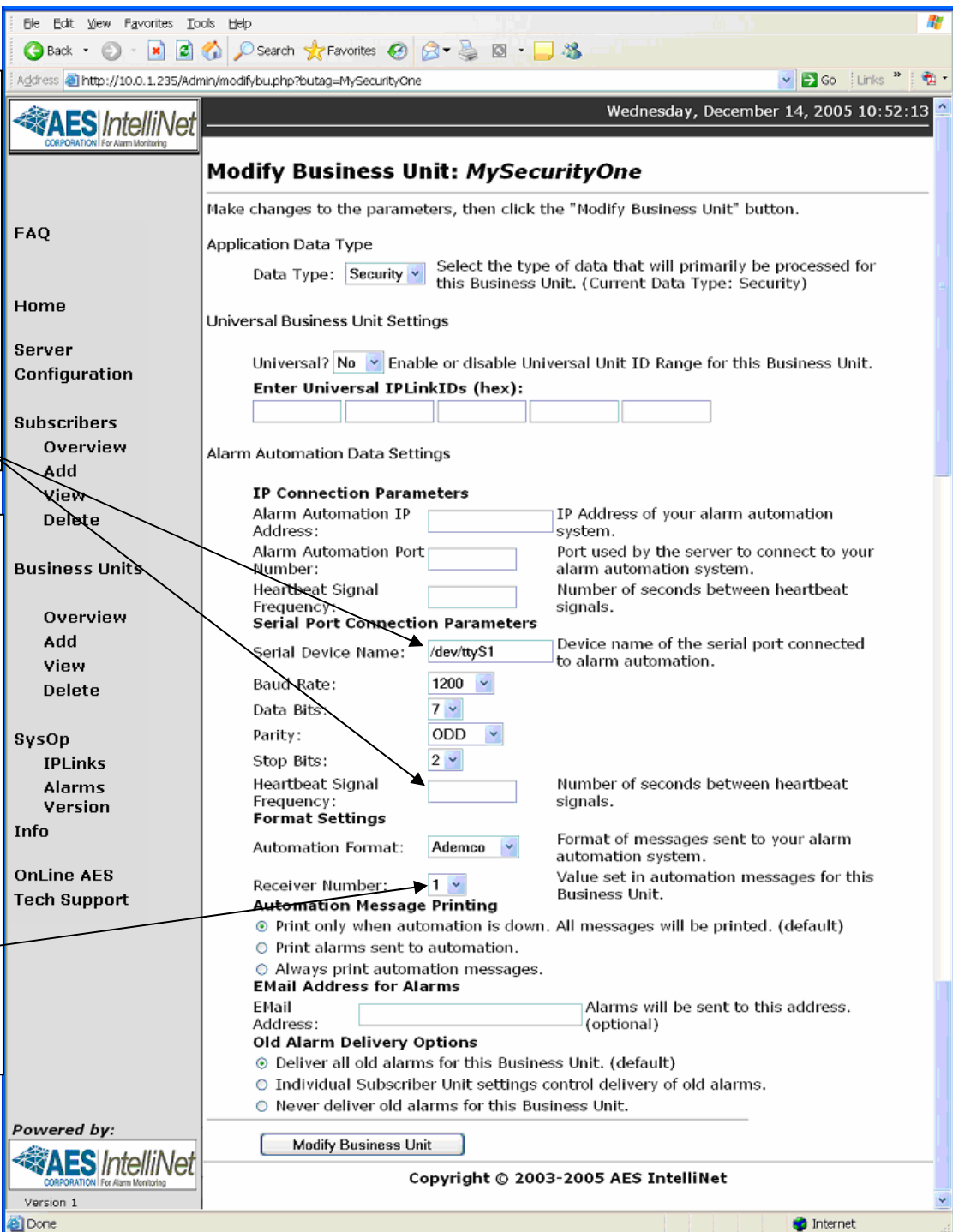
*Figure 6-10 Business Unit Details*

## 6.5 Modify a Business Unit

Select  in Business Unit Details screen to make any changes. The following combined screens image may appear different depending on the type of Business Unit.

Leave these fields blank if this BU will be linked to another that is already configured to use the Serial Port to alarm automation.

Selecting a different receiver number for each BU will produce a unique alarm message for each. This affects the receiver number in the string of characters sent to alarm automation.



**Modify Business Unit: MySecurityOne**

Make changes to the parameters, then click the "Modify Business Unit" button.

**Application Data Type**

Data Type:  Select the type of data that will primarily be processed for this Business Unit. (Current Data Type: Security)

**Universal Business Unit Settings**

Universal?  Enable or disable Universal Unit ID Range for this Business Unit.

**Enter Universal IPLinkIDs (hex):**

**Alarm Automation Data Settings**

**IP Connection Parameters**

Alarm Automation IP Address:  IP Address of your alarm automation system.

Alarm Automation Port Number:  Port used by the server to connect to your alarm automation system.

Heartbeat Signal Frequency:  Number of seconds between heartbeat signals.

**Serial Port Connection Parameters**

Serial Device Name:  Device name of the serial port connected to alarm automation.

Baud Rate:

Data Bits:

Parity:

Stop Bits:

Heartbeat Signal Frequency:

**Format Settings**

Automation Format:  Format of messages sent to your alarm automation system.

Receiver Number:  Value set in automation messages for this Business Unit.

**Automation Message Printing**

Print only when automation is down. All messages will be printed. (default)

Print alarms sent to automation.

Always print automation messages.

**Email Address for Alarms**

Email Address:  Alarms will be sent to this address. (optional)

**Old Alarm Delivery Options**

Deliver all old alarms for this Business Unit. (default)

Individual Subscriber Unit settings control delivery of old alarms.

Never deliver old alarms for this Business Unit.

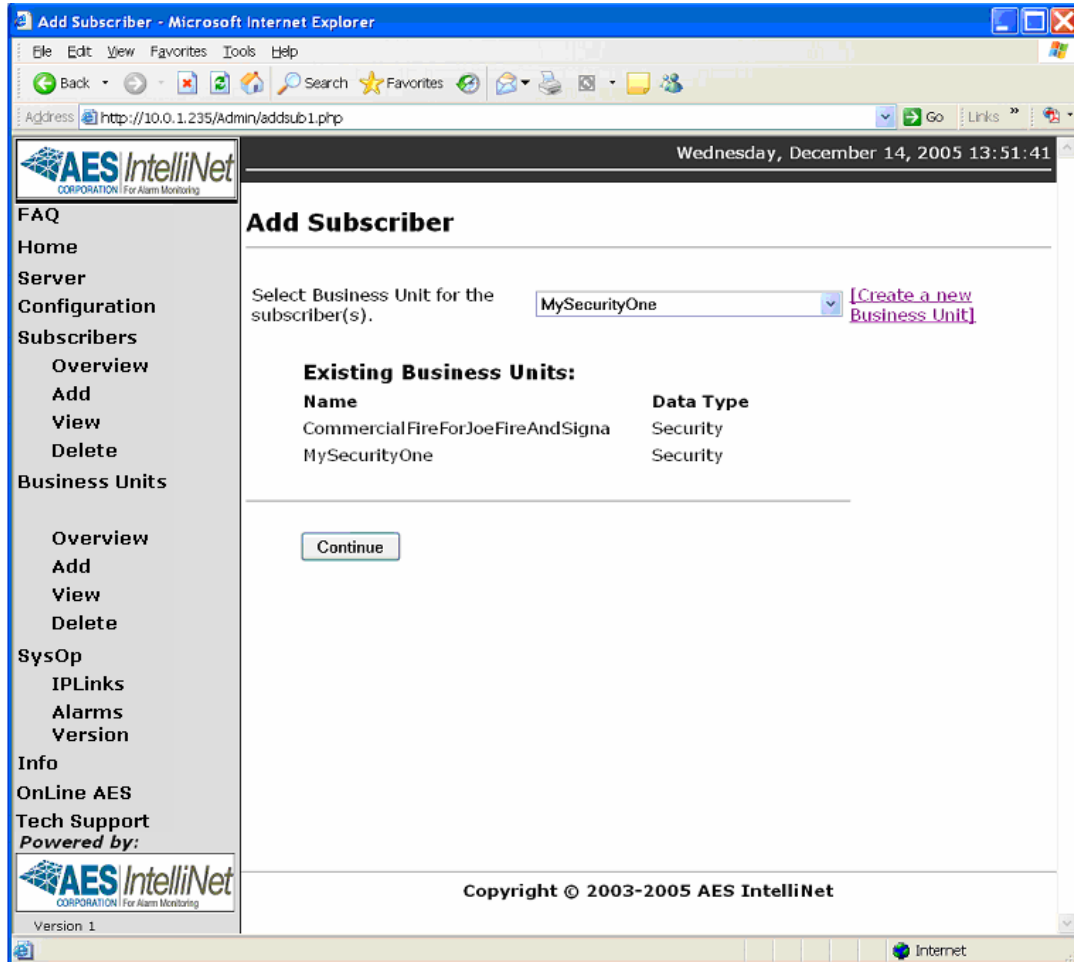
Copyright © 2003-2005 AES IntelliNet

Figure 6-11 Modify Business Unit:

## 6.6 Subscriber Database Setup

Each subscriber unit needs to be configured and assigned to a Business Unit, Subscriber configuration allows you enter the IDs of your units individually, or as a range of IDs within the same Business Unit.

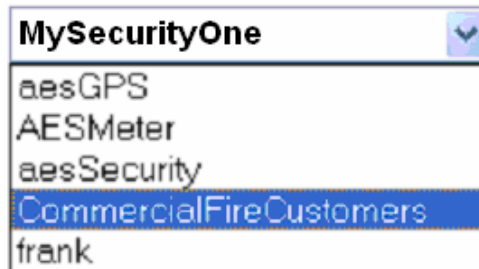
Add subscribers by clicking the link on the left hand menu, “Add” under “Subscribers”.




*Figure 6-12 Add Subscriber*

You will first be prompted to select the Business Unit to assign the added Subscriber.

- **Business Unit:** Select from the pull down list. A different list from another example system is shown in this example.



- After selecting the Business unit, click on  The following fields will be presented.

**Figure 6-13 Add Subscriber to Business Unit Screen**

- **Subscriber ID:** The Add page first asks if you want to configure a single subscriber or a range of subscribers. Configuring a range of subscribers can be convenient if you have a series of subscriber units, consecutively numbered, for the same Business Unit. Enter the subscriber ID(s) and use the radio buttons to indicate whether you are configuring a single subscriber or a range of subscribers.

Subscriber unit IDs can be entered as Hexadecimal or Decimal numbers. Use the radio buttons below the ID entry fields to set the number type.

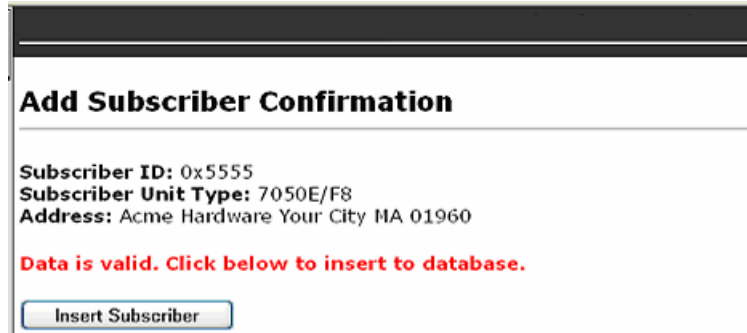
Note: An ID entered in Decimal will be converted to Hexadecimal for use and database storage. Use caution if you enter an ID as decimal as once it is translated into Hexadecimal and stored, you will have to know the Hexadecimal translation to view data on some screens. Subscriber ID's are actually entered in Hexadecimal format when programming the unit using the programming port. Entering the ID of 1234 into a unit would be an equivalent of 4660 in decimal or 6666 entered as decimal will be converted to the Subscriber ID of 1A0A.

When entering a range, decimal and Hex digits will have to be entered separately. A range of 0001 to 9999 will include all ID's with numbers 0-9 but none of the Hex digits A-F. To include the Hex numbers in the range create a René.

- **Unit Type:** Select the unit type from the pull down list provided. If the unit type is not properly selected, certain operational functions, such as Zone Programming, may not work correctly. You may not be presented with the correct zone-programming window.

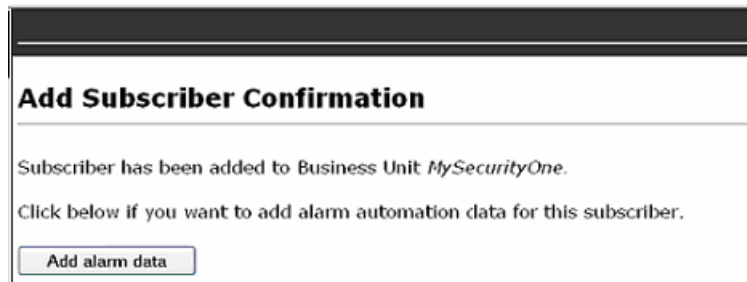
- Enter optional address information in fields **Line 1**, **Line 2**, **City**, **State**, **Zip** and **Country** if desired.

Once fields are edited select “Add Subscriber” button, the next screen will display the data you entered for verification. If displayed data is correct, click the “Insert Subscriber” button to add the subscriber to the database. If it is incorrect, use the “Back” button of your browser to return to the Add Subscriber page to make corrections.



*Figure 6-14 Add Subscriber Confirmation - partial Screen*

You will receive a confirmation screen after you click the “Insert Subscriber” button, verifying that the subscriber was added to the database. From here, select the [Add alarm data] button to configure alarm data for this subscriber.



*Figure 6-15 Add Subscriber Confirmation Screen*


When you successfully add a subscriber, you are given the option to add alarm data after adding the subscriber.

Click  to perform this step next.

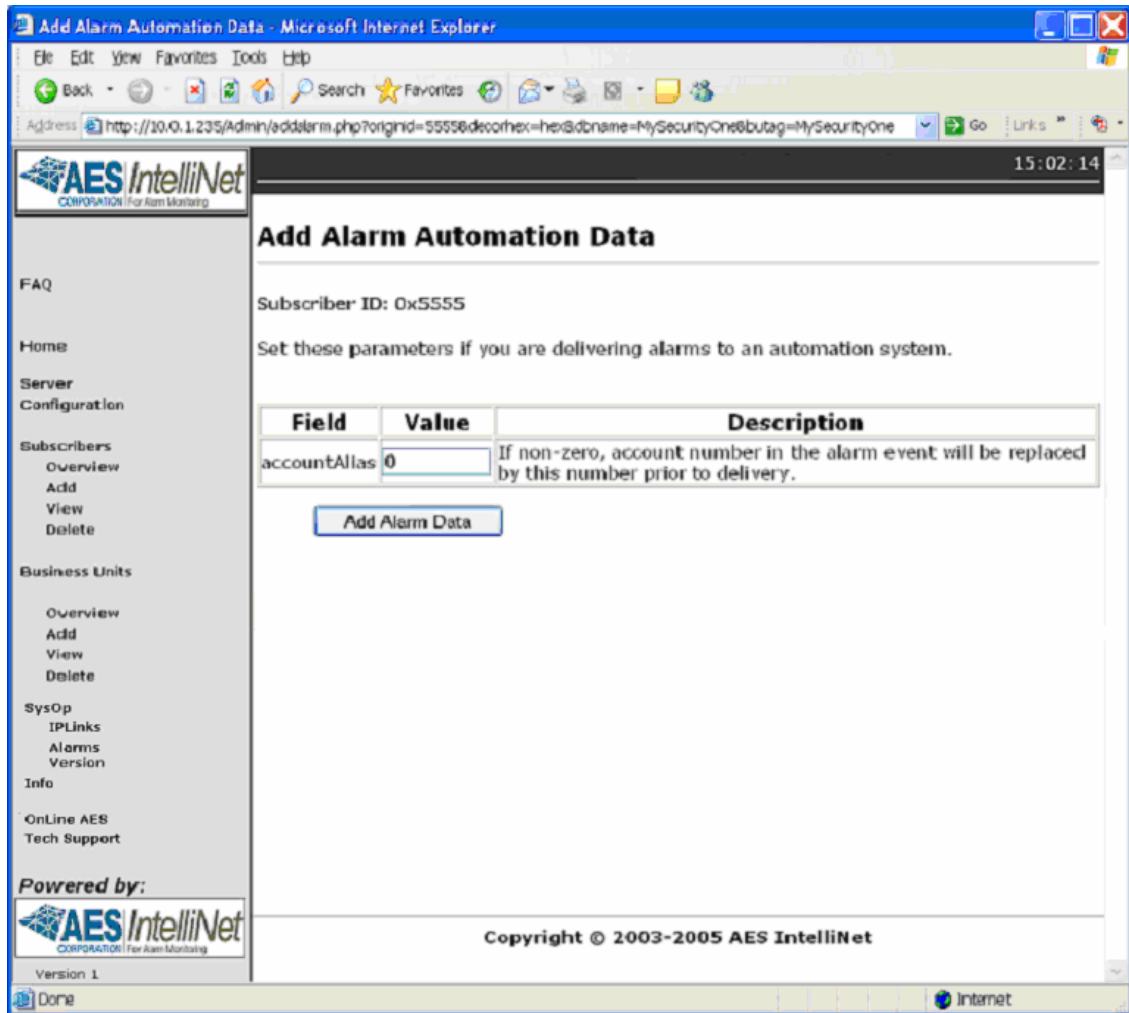
## 6.7 Alarm Data

There are several modifiable parameters that control data sent to the alarm monitoring system by ipctrl.

See [Appendix E](#) for a listing of generated messages.


You can also modify alarm data at a later time by viewing detailed data for the subscriber then clicking the  button on that screen.

The Add Alarm Data page allows you to configure the following alarm parameters for subscribers as shown in the following view of the Add Alarm Data page:



*Figure 6-16*

- **accountAlias:** If a non-zero number is entered into this field, the account number in the alarm event will be replaced by this number prior to delivery to the automation system.

When you have modified the fields click  to accept any changes. The Add Alarm Data screen will ask you to verify the alarm data before it is added to the database.



**Figure 6-17 Add Alarm Data – Insert Alarm Data**

When you add a range of subscribers, you can configure identical alarm parameters for all subscribers in the range. If any subscribers need certain parameters to be different, you can then use the Modify Alarm page to change the parameters for individual subscribers.



**Figure 6-18 Alarm Data Added**

## **6.8 Close Your Browser When Finished With Admin GUI:**

To help secure your MultiNet receivers configuration and help to limit unauthorized modifications to your system, you should close your browser when it is no longer needed. For the same reasons, do not leave untended, a workstation that has the Admin GUI Web pages open.

Closing the browser will require the Admin GUI Password for a subsequent access attempt.



## 7.0 Workstation Access and Login:

Once properly configured, the 7705i can be accessed by using programs running on a workstation. There are as usual multiple configurations and programs that will accomplish this task. As you have already experienced, password protected Web access to the Admin GUI is available as described in [Section 6.0](#). Access using VNC Viewer should have been configured and be running. This should at least be true for user root on display number 1 as well as any users created during the Add Business Unit process.

### 7.1 Programs for Access Via a Workstation

**VNC:** is an acronym for Virtual Network Computing software which makes it possible to view and fully-interact with one computer from another computer. VNC software is cross-platform, allowing control between different types of computers.

Following are instructions for using the AES supplied VNC program with access as root user. Examples show default IP settings and configurations to connect to your MultiNet receiver using a Microsoft Windows workstation. Replace any example IP address with those appropriate for the receiver you are accessing.

**X-Win32:** by StarNet Communications is a third party program that can be purchased independently and installed on a Windows PC. This program allows access without needing to run a special server program on the MultiNet receiver. Check their Web site for latest version and information:

<http://www.starnet.com/>

## 7.2 Installing VNC Viewer:

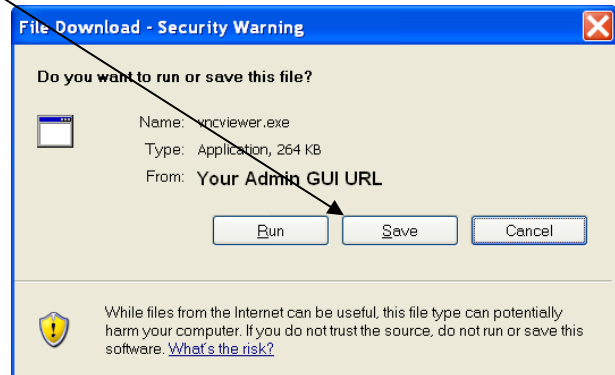
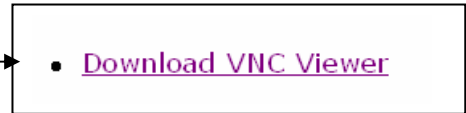
- From a Windows workstation PC, start a Web browser and enter the URL of the Admin GUI on a MultiNet Receiver as described in [Section 6.0](#).

From the main or home page of the Admin GUI there is a link on the bottom of those available on the left side of the screen that can be used to download a copy of the VNC Viewer program.

- Click on the “VNC Viewer” link:
- Click on the “Download VNC Viewer” Link



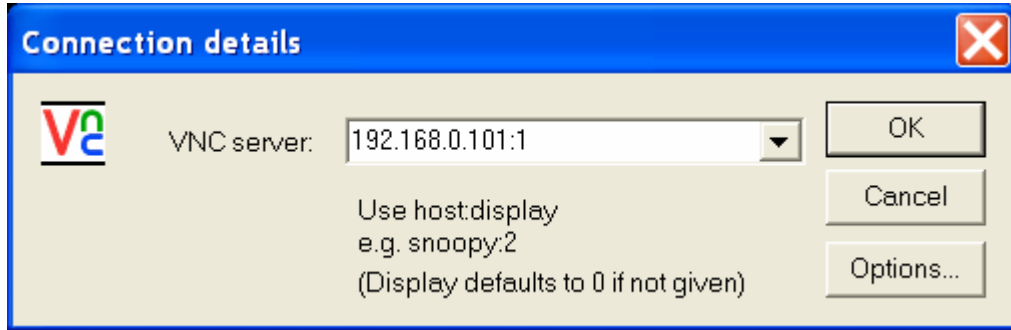
- Click on Save:
- Save the file in an appropriate location that you will remember for the next step. A folder under Program Files would be an appropriate location.
- Create a shortcut on your desktop to the vncviewer.exe file saved in the previous step. Right click on desktop and select new .. Shortcut ... You can use the browse button to look for the file you saved



Double click on the shortcut just created to run VNV Viewer.

### 7.3 Using VNC Viewer:

From a Windows workstation PC, start the VNC Viewer by using the shortcut created in the previous section. The following screen should appear.



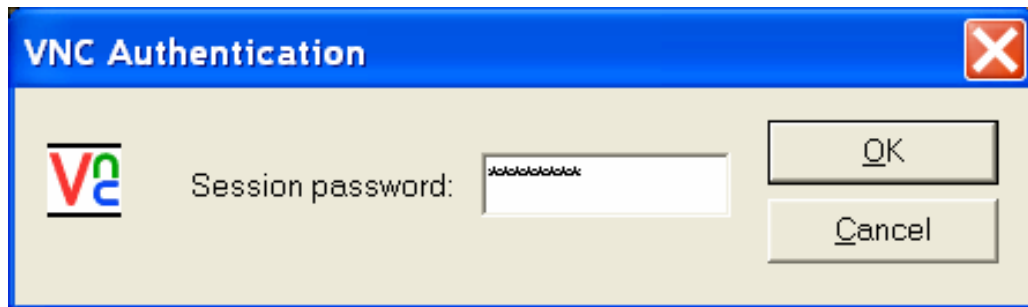
*Figure 7-1 VNC Connection Details Window*

Type into the “VNC server:” box, the IP address and Display number separated by a colon, of the MultiNet Receiver’s VNC Server Display you are attempting to access. The Display number is the unique number created for the user. This Display number is created at the time the Business Unit is created from the Admin GUI Web pages, and will be unique to the specific Business Unit.

Display “:1” is factory created and reserved for root user access. It is the only user that can manage other users. To read the Display numbers and passwords automatically generated and stored in the user\_info file during the add Business Unit process, you must connect using root access on display 1. See [Managing Users in Section 9](#) for additional information.

Example: 192.168.0.101:1 then click [OK]

If successful the following window should appear:



*Figure 7-2 VNC Password Authentication*

Enter the current password for selected user and click OK. The AES factory default password for root using display 1 is peabody2. You should now be connected and be able to run programs as needed.

An example of the screen you should see is in the next section.

## 7.4 After login:

- You should be presented with the Linux MWM GUI Desktop. You will now be able to start the authorized programs and perform functions you need to operate, configure and maintain the system.

An example of the desktop screen as seen using remote access follows:



*Figure 7-3 Remotely accessed GUI Desktop*

Instructions for using the GUI Desktop can be found in:  
[Section 5.7 “The GUI Desktop and the AES Menu:”](#)

If you are connecting for a user associated with a Business Unit you will have the Ipctrl program on the screen. Ipctrl is the interface you will use for managing Subscribers assigned to you.

## 8.0 MultiNet Receiver Programs and Utilities:

There are a number of programs, scripts and special purpose circuits that are installed in an AES MultiNet Receiver. Some are programs that are installed by AES to make your Linux Server a MultiNet Receiver. Others are utilities used to configure and maintain it. There are also a number of others that are part of the operating system installation. Also included are special purpose circuits for monitoring the proper operation of the programs and hardware.

Many programs are started during a normal boot up of the system. Utilities are usually started by request of a user. The following sections explain those that are useful or specific to the operation of the MultiNet Receiver.

### 8.1 MultiNet Specific Programs:

Below is a list followed by a brief description of each of the programs that make up the AES 7705i MultiNet Receiver.

- |            |               |
|------------|---------------|
| 1- ipes    | 4- aesmon     |
| 2- ipctrl  | 5- LCD        |
| 3- deliver | 6- filedaemon |

- 1- ipes** is the server program that communicates with the IP-Link Transceivers. It needs to be configured with a Port Number and ServerID. The setup can be done from the Admin GUI under "[Server Configuration](#)". See [Figure 6-2](#).
- 2- ipctrl** is the Radio Management Program. It is similar to the Net7000 program that standalone *IntelliNet* receivers use. Most of the screen displays network activity. Network activity scrolls up the screen. In normal communication monitoring mode, radio data "traffic" whose destination is the central receiver, and is in range of the IP-Link Transceiver is displayed. This is a valuable tool for monitoring and controlling the RF network.
- 3- deliver** is the program that manages the distribution or sending of alarm messages to the automation system. It is configured using the Admin GUI, shown in [Figure 6-2](#). Deliver can communicate alarm automation messages via RS-232, TCP/IP or both. See [Appendix E](#) for a listing of generated messages.
- 4- aesmon** is a program that monitors the ipes, ipctrl, deliver, LCD and filedaemon programs every 5 seconds to test that these programs are up and running. It restarts any program that is not running.
- 5- LCD** is the program that controls the messages displayed on the LCD display located on the front panel on the 7705i MultiNet Receiver.
- 6- filedaemon** is the program that handles the data sent to the printer. Refer to [Appendix F](#) for a listing of printed messages.

## 8.2 MultiNet Utility Programs and Scripts:

Listed below are some of the more commonly used programs, utilities and script files provided by AES or your Linux installation to manage, configure and maintain your MultiNet Receiver

- |              |                    |
|--------------|--------------------|
| 1- Admin GUI | 4- cleanLCD        |
| 2- aesctrl   | 5- editnetworketh0 |
| 3- chpass    | 6- editnetworketh1 |

### 1- Admin GUI: (Graphical User Interface)

The Admin GUI is essentially a collection of Web pages that an administrator can use to manage a MultiNet System. You can use a web browser to access the Admin GUI Web pages. The Web browser can be run on a workstation with access to the MultiNet Receiver's network or from the Web browser included in the MultiNet Receiver's installed software packages.

- If accessing the Web pages from a network workstation use the IP address of the MultiNet receiver as configured in [section 5](#).  
Default for Receiver would be:  
`http://192.168.0.101/Admin/home.php`
- If accessing the Web pages from the MultiNet Receiver's keyboard and monitor use the following URL:  
`http://localhost/Admin/home.php`.

The Admin GUI is a php program that allows the operator Admin, to modify the server's configuration, Add Business Units (configure the delivery program if any) and Add Subscriber Units.  
See illustrations beginning with [Figure 6-2](#).

- 2- **aesctrl** [stopall | startall | status] is a command script that allows the operator to stop and start the programs from the source. Arguments are added to the command line to instruct this script how to proceed. **aesctrl** is typed into the command line with an argument added as described below:

This command with the startall argument will attempt to start every ipctrl Business Unit, ipes, aesctrl, deliver, aesmon and filedaemon.

Use the following command to start the MultiNet programs:

**aesctrl startall<Enter>**

You will need to close the terminal window and open a new one after executing this command as commands will scroll on the screen regularly.

This command with the stopall argument is used to stop the programs listed above. Use the following command to start the MultiNet programs:

**aesctrl stopall<Enter>**

This command with the status argument is used to get the status of the programs listed above. Use the following command to get the status of the MultiNet programs and determine if it is running:

**aesctrl status<Enter>**

- 3- **chpass** is script is used to change the password of a user created by the new Business Unit function in the Admin GUI Web pages. You will be asked for the username and new password. Passwords must be exactly 8 characters made up of case sensitive letters and numbers. New passwords will take affect after executing this command because the VNC Server session for the user that the password is changing will be shutdown and restarted within this script.
- 4- **cleanLCD** Clears alarm messages on the LCD display.
- 5- **editnetworketh0** – This script is used to modify the settings of Ethernet Port 1 (eth0). See [Section 5.13](#)
- 7- **editnetworketh1** – This script is used to modify the settings of Ethernet Port 2 (eth1). See [Section 5.13](#)

### 8.3 Special Purpose Circuits:

Listed below are some of the notable special purpose circuits whose purpose is to monitor certain faults or the proper operation of the MultiNet Receiver.

- 1- Watchdog Timer / Hung process detection
- 2- Power Supply Overheating Detection

**1- Watchdog Timer / Hung process detection:** Many of the critical programs in the MultiNet Server suite are providing a pulse to a Watchdog circuit on the LCD Board. The purpose of this pulse is to verify that the programs are performing their functions in a timely manner and not hung.

To test for the existence of an operational Hard Drive, many of the programs are accessing the drive at regular intervals. If a program becomes hung for any reason including its inability to access the drive, the Watchdog Circuit will not receive the pulse. If the Watchdog circuit does not receive a pulse, the MultiNet Receiver will annunciate the fault within 90 seconds.

To annunciate this fault condition, which includes a lost or failed hard disk drive, the following will occur:

- At about 1 minute the LCD will display the message:  
"COMM FAILED"  
"VERSION ####"
- At about 90 seconds:
  - The Alert Sounder will activate
  - The CPU and Alert LED will illuminate

Pressing the Silence Button should silence the Alert Sounder.

If the Acknowledge Button is pressed, the LEDs will clear but the fault will be re-annunciated in several seconds. This fault cannot be acknowledged.

Although it is possible that the MultiNet Receiver may continue to process signals for some period of time, total failure is imminent and corrective action must be taken. Never continue to operate the MultiNet receiver when the Alert LED cannot be cleared.

**2- Power Supply Overheating Detection:** A temperature sensor is incorporated into the power supply. If it detects a temperature above its normal operational range, the following will occur"

- The Alert Sounder will activate
- The Silence and Acknowledge Buttons will have no affect on the Sounder.

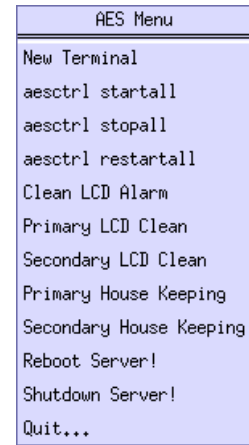
Although it is possible that the MultiNet Receiver may continue to function normally and process signals for some period of time, failure is possible and corrective action must be taken. Never continue to operate the MultiNet receiver when the Sounder is active and cannot be silenced.



## 8.4 AES Menu in the GUI Desktop:

There are no desktop shortcuts on the MultiNet Receiver's GUI Desktop. Use the AES Menu to access some of functions that are available. Other functions are available from the command line prompt. This menu is only available for root user access. See [Section 5.7](#)

- 1- **New Terminal** – Shortcut to start the xterm terminal emulator used to get a command line prompt.
- 2- **aesctrl startall** – Shortcut to run the startALL shell script which starts the collection of programs that make up the MultiNet receiver.
- 3- **aesctrl stoptall** – Shortcut to run the stopALL shell script which stops the collection of programs that make up the MultiNet receiver.
- 4- **aesctrl restartall** – Shortcut to run the restartALL shell script which stops then restarts the collection of programs that make up the MultiNet receiver.
- 5- **Clean LCD Alarm** – Shortcut to reset the LCD display
- 6- **Primary LCD Clean** – Shortcut to reset the LCD display
- 7- **Secondary LCD Clean** – Shortcut to reset the LCD display
- 8- **Primary Housekeeping** – Shortcut to reset LEDs
- 9- **Secondary Housekeeping** – Shortcut to reset LEDs
- 10- **Reboot server!** – Shortcut to stop all programs, shut down and restart the MultiNet receiver.
- 11- **Shutdown Server!** – Shortcut to properly stop all programs and shut down the MultiNet receiver. You should never just remove power from the receiver or turn off the power supply On/Off switch to turn off the receiver. Damage to the file system may occur if not properly shut down.
- 12- **Quit...** - Use this function to quit using the MWM GUI and return to a command prompt.



**Figure 6-1**  
**AES menu**

## 9.0 Managing Users:

Generally, users are created and managed within the MultiNet system through the creation of the Business Unit. [See section 6.2](#). Within a server environment a user would be given specific access rights to areas on a server where they could do things such as view, create, delete, modify and other actions to files while limiting access to areas where they do not need to be. This protects the system and other users.

User “root” and several other users were created on your MultiNet receiver at the factory. Default passwords were assigned to those users. User root is typically the most powerful user in a Linux server and has access to do anything on the server. Other factory created users are AES Engineering and Technical Support user access accounts that were created to provide factory assistance and support for your system and the passwords are not published.

You should change the factory default password for user root to protect against unauthorized access. See [“Changing a user’s Password”](#) below.

Remote access to a MultiNet receiver is possible once attached to a network. The VNC Server program is configured to start automatically on boot up and this will allow remote access. There are also other readily available programs that can gain access without special programs running on the receiver. Not changing the password could easily allow remote access to those that know or discover the server exists on an available network.

Where users are mostly managed by the creation and deletion of the Business unit, you will not typically need to create your own users directly. Changing passwords of a user is one operation that must be done outside the Admin GUI. See [“Changing a user’s Password”](#) below.

### 9.1 Adding a user:

This is done when you create a Business Unit. The username is the name you give to the Business Unit during the Add Business Unit process.

### 9.2 Retrieving user Display Number and Password:

An initial password and a unique Display number are generated automatically during the Add Business Unit process. The password and Display number for users created in the Admin GUI are located in the file named “user\_info” located in root directory. Only the root user can read the file. This is the directory you would be looking at after a successful login as user root. Type the following command at a command prompt to view this file:

```
cat user_info<Enter>
```

After reviewing the information press Q to quit the viewer and return to the command prompt:

If you are not in the root directory or to be sure you are type the following:  
`cd /root<Enter>`

Or to view the from any other directory type the following command:

```
cat /root/user_info<Enter>
```

### 9.3 Changing a user's Password:

AES has provided a script for use in changing the password of a user that already exists. Only the root user can change passwords using this script.

**Warning!** This script should also successfully change the password for user root, but be very careful as the VNC Server for the user is stopped and restarted during this process effectively disconnecting you if the password being changed is for the root user and you are connected via VNC Viewer. Be prepared for your VNC Viewer session to close.

At the command prompt enter the following:

**chpass<Enter>**

The script will ask for the username:

**Enter the user name whose password you wish to change:**

**{username/Business Unit Name}<Enter>**

If the user is found, the script will ask for the new password:

(The password must be exactly 8 characters of case sensitive letters and numbers)

**User OK. Please enter user's new password:**

**{new password}<Enter>**

You must enter the password a second time. The two will be compared.

**Please enter the password again:**

**{new password}<Enter>**

A response by the script will let you know if it was successful or what error was encountered.

Select a password that is appropriate for the user you are creating. The more complex it is the more secure your system will be and the less likely that an attacker will guess it and gain access. Using telephone numbers, birthdays and the like are not recommended and could be easier to guess leaving your system at risk. An example is something similar to: "Ax2zT78o".

## 9.4 Change Admin GUI Access - Username and Password:

The username and password used to gain access to the Admin GUI is factory set as username = Admin; Password = peabody. It is highly recommended that this password be changed. Not changing it means that anyone who knows or discovers the server could use the Admin GUI Web pages to modify and possibly disable your system. The factory default passwords are published.

Follow these steps to change the username and password for Admin GUI access. You can keep the same name by simply typing that name on the command line in place of newname.

- Start VNC Viewer or use local access and log in to the MultiNet Receiver as root and get to a command prompt.
- Enter the following command to change to the directory where the Web Server files are located:  
**cd /usr/local/apache/bin<Enter>**
- Enter the following command to change the username and password for access to the Admin GUI login:  
**./htpasswd -c /usr/local/apache/htdocs/admin.users {newname}<Enter>**
- You will be prompted for a new password twice.  
Enter the new password twice.
- Enter the following command to stop the apache Web Server.  
./apachectl stop<Enter>
- Enter the following command to start the apache Web Server.  
./apachectl startssl<Enter>
- Once restarted the new username and password should be in effect.
- Attempt to access the Admin GUI using the new username and password

## 9.5 Deleting a User:

This is managed by the deletion of the Business Unit within the Admin GUI.

## 9.6 Test new user login:

New user access should be tested after creating a Business Unit or changing a password. Read or confirm the new password and Display number from the file `user_info` as described above in [Section 9.2](#). Log in using the new login information to verify the proper creation/modification of the user.

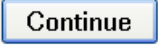
- If you are working from a remote workstation, you can test as outlined below:
  - Determine the display number and password by looking in the `user_info` file.  
**cat /root/user\_info<Enter>**
  - Open a new VNC Viewer and use the display number and password determined above.
  - If operation appears normal you were successful.
  - Close the VNC Viewer.
- If you are working from the directly attached keyboard and monitor, you can test as outlined below:
  - If using the Linux MWM GUI, select “**Quit...**” from the AES menu.
  - Next type **exit<Enter>** or **logout<Enter>** from the command line prompt.
  - At the “aes login:” prompt type **{username}<Enter>** replacing username with the name of the Business Unit you are testing.
  - Enter the password followed by **<Enter>** when prompted.
  - Once successful, confirmed with a prompt including the username you typed, you should logout again. Type **logout <Enter>**

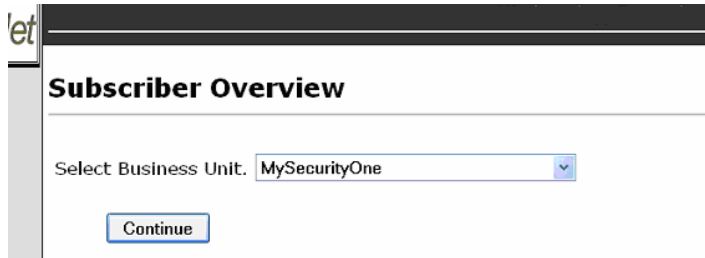
## 10.0 Admin GUI Database Functions:

Once your AES MultiNet system is up and running, and has received signals from Subscribers, you can use the Admin GUI access to monitor Subscriber activity history. Admin GUI is usually accessed from your remote PC.

### 10.1 Subscriber Overview

Following is a portion of the screen that is displayed when you select Subscriber / Overview. To review details about a specific unit select a

Business Unit from the pull down and then click .



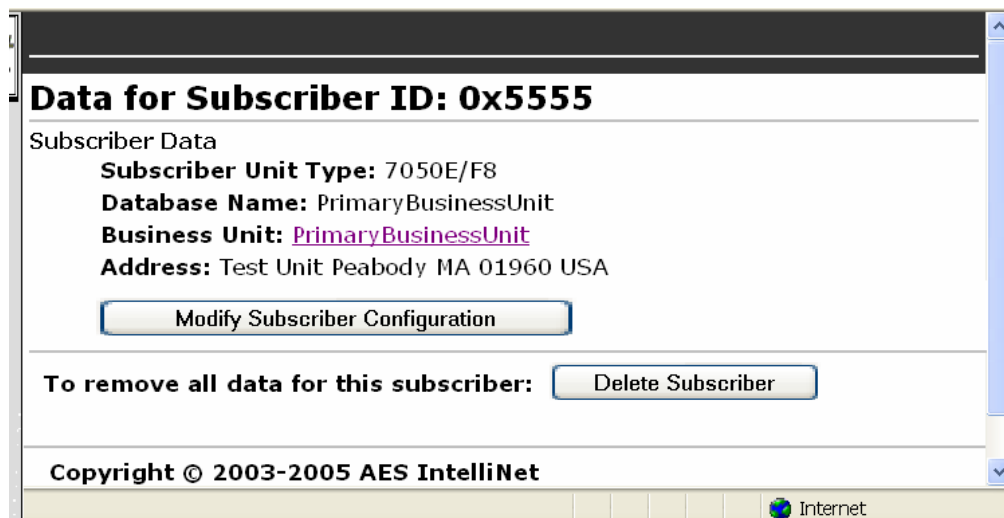
*Figure 10-1 Select Business Unit*

The next screen will allow you to select a subscriber from the list.



*Figure 10-2 Select Subscriber ID*

The next screen will provide the options to Modify Subscriber Configuration, Alarm Data or Delete Subscriber. By now you should have seen most of those screens.



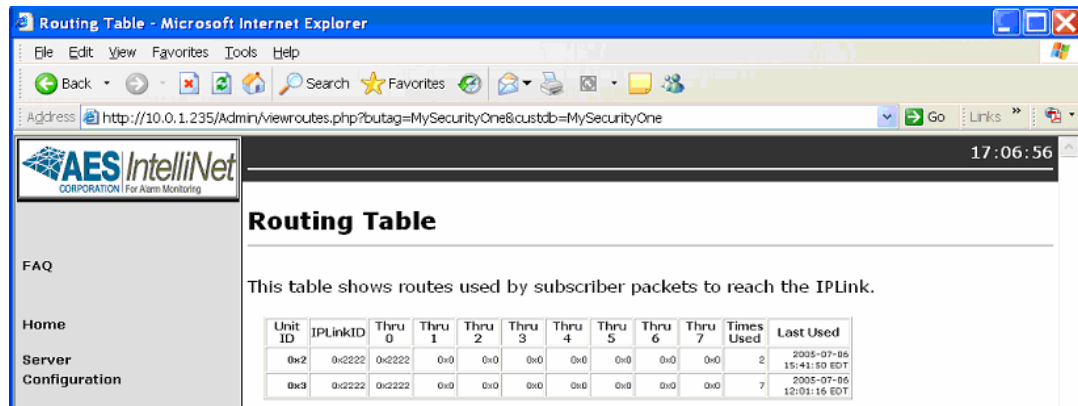
*Figure 10-3 Data for Subscriber*

## 10.2 Routing Table Screen:

Once you have configured your Business Unit(s) and added Subscribers you can go to the ipctrl program discussed later in this manual, to view live traffic and manage your network. Data will be stored in the various databases as traffic comes in. You can then return to the Admin GUI and review that data using the following screens.

You can view Routing information by selecting a link located in the Business Units area of the Admin GUI. Select Business Units / Overview on the left side of the screen. Then select the Business Unit that contains the Subscriber you want to review routing history from the pull down list. Next click on the Link “View Route table for {Business Unit Name}”.

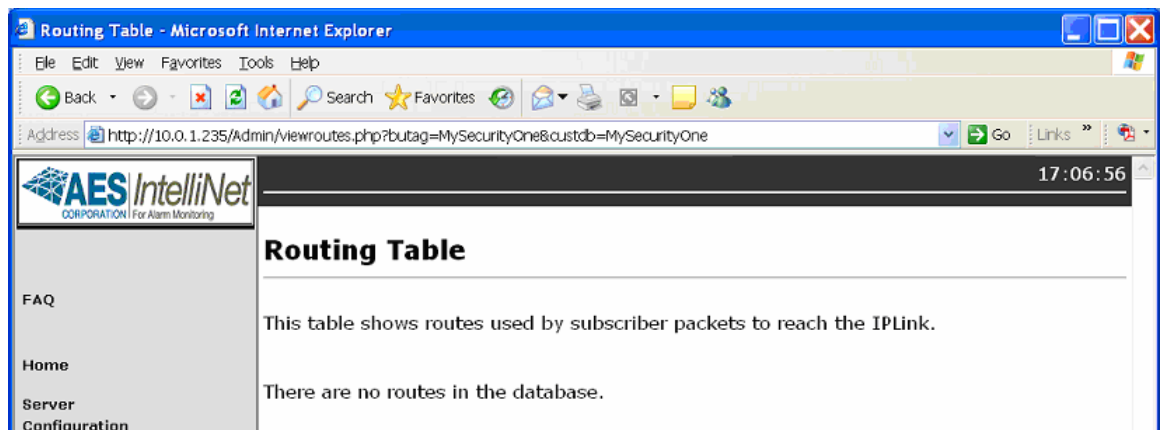
An example screen is shown below. When your system is new there may not be any information to display until signals are successfully received by an IP-Link Transceiver and passed on to the 7705i MultiNet Receiver.



Unit ID	IPLinkID	Thru 0	Thru 1	Thru 2	Thru 3	Thru 4	Thru 5	Thru 6	Thru 7	Times Used	Last Used
0x2	0x2222	0x2222	0x0	0x0	0x0	0x0	0x0	0x0	0x0	2	2005-07-05 15:41:50 EDT
0x3	0x2222	0x2222	0x0	0x0	0x0	0x0	0x0	0x0	0x0	7	2005-07-05 12:01:16 EDT

**Figure 10-4 Routing Table**

*Note:* The information on this screen will vary from what is shown depending on whether any and what signals may have been received by this 7705i MultiNet Receiver.



**Figure 10-5 Empty Routing Database**

### 10.3 IP-Link Status Screen:

You can also view the status of IP-Link transceivers as shown in this partial screen view accessed from SysOp / IPLinks:

**IPLink Status**

This table shows statistics for IPLinks that have connected to this server. The "Statistics Start" column shows the time data collection started.

You can clear this data and restart statistics collection by clicking the "Reset" button for each IPLink.

IPLinkID	Version	Supervision Interval Seconds	Statistics Start	Connect Count	Packet Count	PP Packet Count	Average Connect Frequency (seconds)	Last Connection	Reset Statistics
0x1111	S0.6.7	120	2005-12-14 19:26:19 EST	4	4	0	1	2005-12-14 19:26:23 EST	<input type="button" value="Reset"/>

Figure 10-6 IP-link Transceiver Status Screen

### 10.4 Get Signal History:

Alarm data that is stored can also be viewed. The following screen, accessed by selecting SysOp / Alarms, lets you select the specifics about the alarm data you wish to view.

Get Alarm Status - Microsoft Internet Explorer

Address: http://10.0.1.235/Admin/alarquery.php

10:30:43

**Get Alarm Status**

You may select alarms by Business Unit and Tracking Number or Subscriber ID.

Select Business Unit:  Tracking Number:  (optional)

Or

Subscriber ID:  (hexadecimal)

Enter Alarm Date:  as yyyy/mm/dd (optional)

Figure 10-7 Get Alarm data, (Signal History) request screen



Shown in the following Figure is an example of a Signal History Screen for a Subscriber with an ID of 1010:

(This page will automatically refresh every 60 seconds.)

UnitID	Alarm Text	Alarm Time	Tracking Number
1010	Account 1010 (New) Type = Supervisory ID = 1010 Code = 000 [Output=Yes] @ Wed Jul 6 16:18:03 2005	2005-07-06 16:18:03	88
1010	Account 1010 (New) Type = Supervisory ID = 1010 Code = 000 [Output=Yes] @ Wed Jul 6 16:15:04 2005	2005-07-06 16:15:04	87
1010	Account 1010 (New) Type = Supervisory ID = 1010 Code = 000 [Output=Yes] @ Wed Jul 6 16:12:07 2005	2005-07-06 16:12:07	86
1010	Account 1010 (New) Type = Supervisory ID = 1010 Code = 000 [Output=Yes] @ Wed Jul 6 16:09:00 2005	2005-07-06 16:09:00	85
1010	Account 1010 (New) Type = Supervisory ID = 1010 Code = 000 [Output=Yes] @ Wed Jul 6 16:06:15 2005	2005-07-06 16:06:15	84
1010	Account 1010 (New) Type = Supervisory ID = 1010 Code = 000 [Output=Yes] @ Wed Jul 6 16:03:12 2005	2005-07-06 16:03:12	83
1010	Account 1010 (New) Type = Supervisory ID = 1010 Code = 000 [Output=Yes] @ Wed Jul 6 16:00:14 2005	2005-07-06 16:00:14	82
1010	Account 1010 (New) Type = Supervisory ID = 1010 Code = 000 [Output=Yes] @ Wed Jul 6 15:57:15 2005	2005-07-06 15:57:15	81
1010	Account 1010 (New) Type = Supervisory ID = 1010 Code = 000 [Output=Yes] @ Wed Jul 6 15:54:17 2005	2005-07-06 15:54:17	80
1010	Account 1010 (New) Type = Supervisory ID = 1010 Code = 000 [Output=Yes] @ Wed Jul 6 15:51:19 2005	2005-07-06 15:51:19	79
1010	Account 1010 (New) Type = Supervisory ID = 1010 Code = 000 [Output=Yes] @ Wed Jul 6 15:48:21 2005	2005-07-06 15:48:21	78
1010	Account 1010 (New) Type = Supervisory ID = 1010 Code = 000 [Output=Yes] @ Wed Jul 6 15:45:23 2005	2005-07-06 15:45:23	77
1010	Account 1010 (New) Type = Supervisory ID = 1010 Code = 000 [Output=Yes] @ Wed Jul 6 15:42:25 2005	2005-07-06 15:42:25	76
1010	Account 1010 (New) Type = Supervisory ID = 1010 Code = 000 [Output=Yes] @ Wed Jul 6 15:39:28 2005	2005-07-06 15:39:28	75
1010	Account 1010 (New) Type = Supervisory ID = 1010 Code = 000 [Output=Yes] @ Wed Jul 6 15:36:30 2005	2005-07-06 15:36:30	74
1010	Account 1010 (New) Type = Supervisory ID = 1010 Code = 000 [Output=Yes] @ Wed Jul 6 15:33:32 2005	2005-07-06 15:33:32	73
1010	Account 1010 (New) Type = Supervisory ID = 1010 Code = 000 [Output=Yes] @ Wed Jul 6 15:30:35 2005	2005-07-06 15:30:35	72

*Figure 10-8 An example Alarm Data (Signal History) Screen*

## 10.5 Close Your Browser When Finished With Admin GUI:

To help secure your MultiNet receivers configuration and help to limit unauthorized modifications to your system, you should close your browser when it is no longer needed. For the same reasons, do not leave untended, a workstation that has the Admin GUI Web pages open.

Closing the browser will require the Admin GUI Password for a subsequent access attempt.

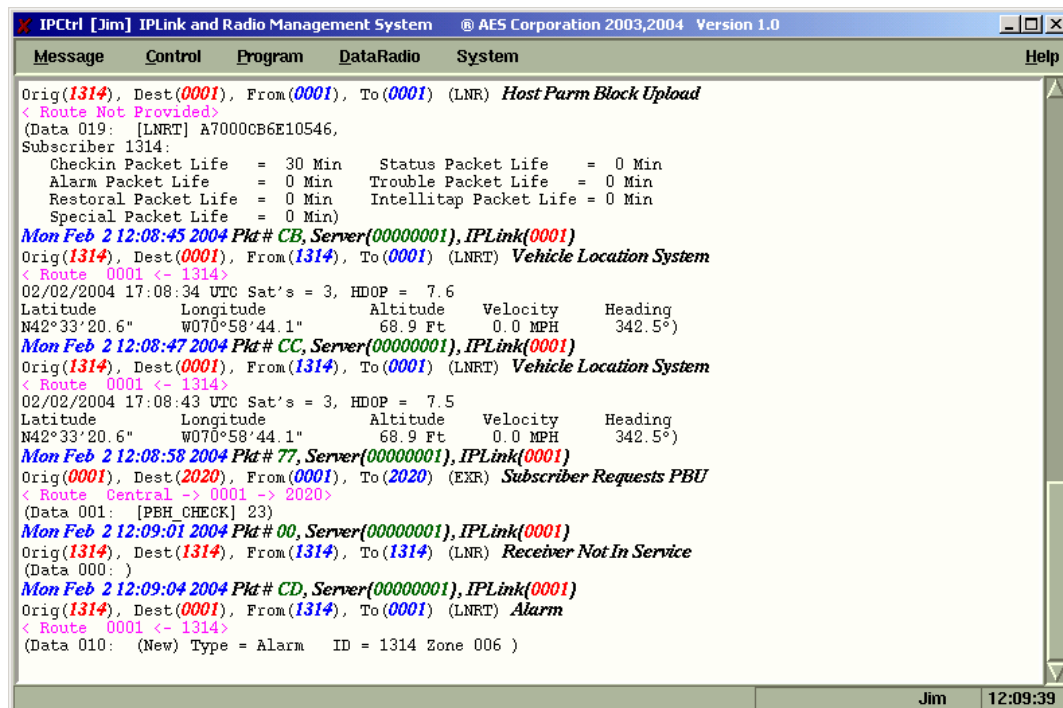
## 11.0 IPLinkCtrl (ipctrl) Network Management Software:

Once your AES MultiNet system is up and running, you can use the IPCtrl program to monitor and manage your network. IPCtrl is usually accessed from the workstation PC that is connected using VNC Viewer.

If the program IPCtrl is not running it can be started using the “aesctrl startall” item in the AES Menu, accessed by a right click on the Desktop or by entering the **startALL<Enter>** command.

IPCtrl is the IP-Link and Radio Management program. For those familiar with standalone AES IntelliNet receivers this is the replacement for Net7K or Net7000. Unlike Net7000 programs, which are connected directly to a receiver that is viewing RF signals in real time, IPCtrl displays data packets that are delivered by a 7170 IP-Link transceiver.

Following is an example of the IPCtrl screen.



```
IPCtrl [Jim] IPLink and Radio Management System @ AES Corporation 2003,2004 Version 1.0
Message Control Program DataRadio System Help
Orig(1314), Dest(0001), From(0001), To(0001) (LNR) Host Parm Block Upload
< Route Not Provided>
(Data 019: [LNRT] A7000CB6E10546,
Subscriber 1314:
  Checkin Packet Life = 30 Min Status Packet Life = 0 Min
  Alarm Packet Life = 0 Min Trouble Packet Life = 0 Min
  Restoral Packet Life = 0 Min Intellitap Packet Life = 0 Min
  Special Packet Life = 0 Min)
Mon Feb 2 12:08:45 2004 Pkt# CB, Server(00000001), IPLink(0001)
Orig(1314), Dest(0001), From(1314), To(0001) (LNRT) Vehicle Location System
< Route 0001 <- 1314>
02/02/2004 17:08:34 UTC Sat's = 3, HDOP = 7.6
Latitude Longitude Altitude Velocity Heading
N42°33'20.6" W070°58'44.1" 68.9 Ft 0.0 MPH 342.5°
Mon Feb 2 12:08:47 2004 Pkt# CC, Server(00000001), IPLink(0001)
Orig(1314), Dest(0001), From(1314), To(0001) (LNRT) Vehicle Location System
< Route 0001 <- 1314>
02/02/2004 17:08:43 UTC Sat's = 3, HDOP = 7.5
Latitude Longitude Altitude Velocity Heading
N42°33'20.6" W070°58'44.1" 68.9 Ft 0.0 MPH 342.5°
Mon Feb 2 12:08:58 2004 Pkt# 77, Server(00000001), IPLink(0001)
Orig(0001), Dest(2020), From(0001), To(2020) (EXR) Subscriber Requests PBU
< Route Central -> 0001 -> 2020>
(Data 001: [PBH_CHECK] 23)
Mon Feb 2 12:09:01 2004 Pkt# 00, Server(00000001), IPLink(0001)
Orig(1314), Dest(1314), From(1314), To(1314) (LNR) Receiver Not In Service
(Data 000: )
Mon Feb 2 12:09:04 2004 Pkt# CD, Server(00000001), IPLink(0001)
Orig(1314), Dest(0001), From(1314), To(0001) (LNRT) Alarm
< Route 0001 <- 1314>
(Data 010: (New) Type = Alarm ID = 1314 Zone 006 )
Jim 12:09:39
```

Figure 11-1 Sample screen from the IPCtrl program

## 11.1 IPCtrl Function Groups:

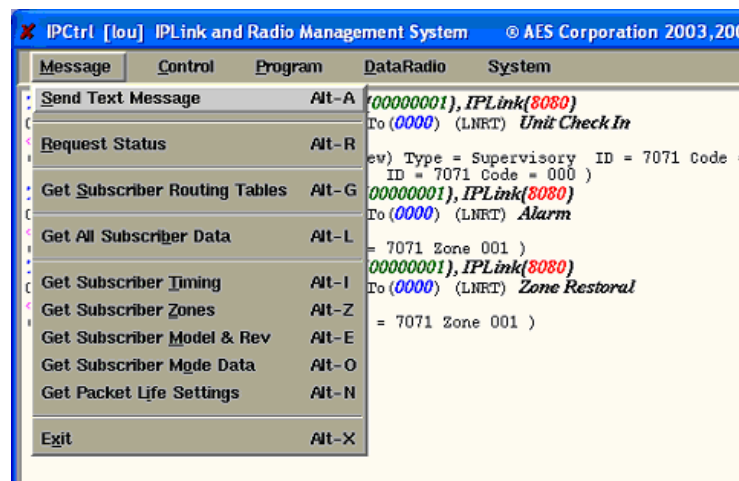
There are five function groups including “Message”, “Control”, “Program”, “DataRadio” and “System”

They are accessed from the menu bar in the upper part of the screen. Each of the menu bar function groups has an underlined letter.

Menu function groups can be selected by holding down the <Alt> key pressing the function group’s underlined letter on your keyboard please see [example on next page](#): or by clicking on the Menu Item with the mouse cursor.



## 11.2 Common data entry/selection menus and pop-ups:



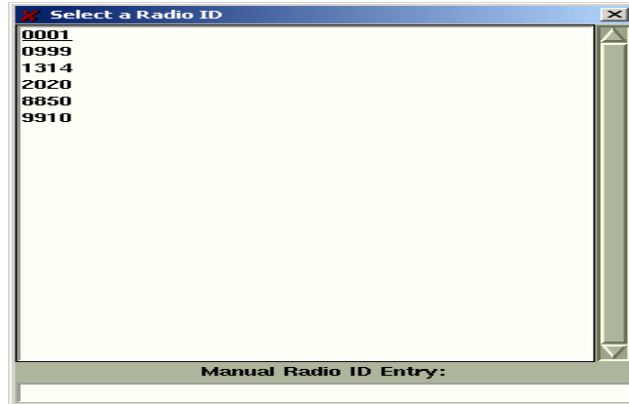
*Figure 11-2 Message Pull down Menu*

- The first of the pull down functions **S**end Text Message in the example above, is highlighted as illustrated when the pull down opens.
- Other functions within the pull downs can be selected using the arrow keys.
- The highlighted function bar also follows the mouse cursor.
- The highlighted pull-down functions will be executed when the user presses <Enter> or clicks on the function bar using the mouse.
- Each listed function has an underlined letter in its name. Pressing the highlighted letter while the pull down is active will execute that function.
- Functions can also be accessed directly by a “hot key”, combination like”<Alt> + <A>. Hot key combinations are listed in the menu to the right of the item. Hot keys will only execute the associated function when the pull downs are closed.
- Activate any other function group by clicking on the function group name in the Menu bar.

### 11.3 Using the pick list pop up to Select a Subscriber ID

When a function is chosen from a function group, a “pick list pop-up” appears.

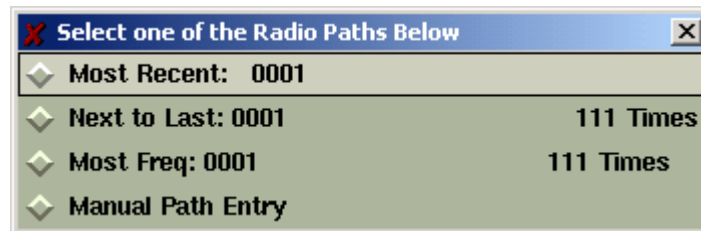
You can type in the ID number of the Subscriber unit you wish to contact. Or use the arrow key to highlight the appropriate ID number and then press <Enter> to select it.



*Figure 11-3 Pick list pop-up*

### 11.4 Selecting a Route for Communication with a Subscriber Unit

Since each subscriber unit in your **AES•IntelliNet** system acts as a radio repeater, there may be many routes for messages to travel from its source to the Linux Server via the IP-Link(s). Each time a message is received from a unit, the software extracts the subscriber unit ID number of the origin, and the ID number of repeaters in the message’s route. That route information is stored in a database and can be used to select an outbound route whenever an operator sends data to a subscriber unit from the Linux Server.

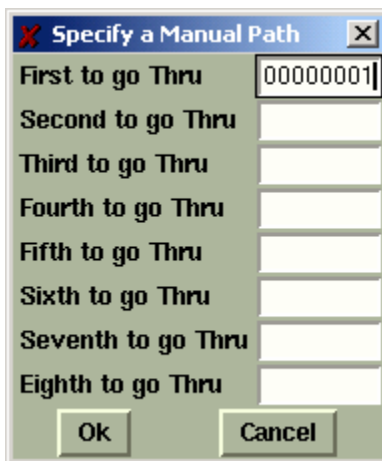


*Figure 11-4 Select a Path*

Once you have selected the subscriber unit number, the basic routing pop-up appears (shown above). You may communicate with the unit through its most recent route, through its next most recent route, through its most frequently used route, or you may manually enter a route.

To choose the most recent route of communication, simply press <Enter> or check the first box. The “last” route, or most recent route, is the default setting on this popup. To select the second most recent route, select the most recent route, and the same for the most frequent route.

To manually enter a route to the subscriber unit, select the Manual Path Entry and fill out the manual routing screen as instructed below. Where the first to go thru is the ID of the IP-Link.



*Figure 11-5 Manual Routing Table*

Once you have entered your communications route, click OK to send the message to your subscriber unit using the route entered.

## 11.5 The Message Function Group:



*Figure 11-6 Message Pull Down Menu*

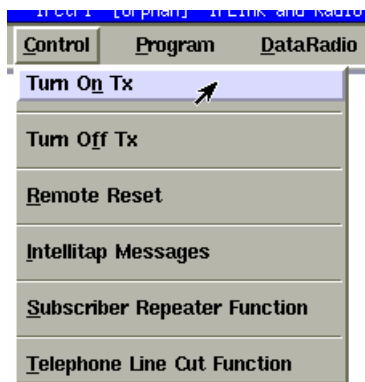
To access the Message function menu group, hold down the <Alt> key and Press <M> or click on Message in the menu bar. The pop-up illustrated above will appear. Use the arrow keys to highlight a message function and press <Enter> to select it. Proceed by selecting your target unit and choosing a route of communication.

## Explanation of the Message Group Functions:

Function	Explanation
<p><b>SEND TEXT MESSAGE</b></p> <ul style="list-style-type: none"> <li>• Press &lt;ALT&gt;+&lt;A&gt; or &lt;ALT&gt;+&lt;M&gt;, then &lt;S&gt;</li> <li>• Select Target Unit</li> <li>• Select Route</li> <li>• Type text message</li> <li>• Press &lt;ALT&gt;+&lt;S&gt; to send</li> </ul>	<ul style="list-style-type: none"> <li>• Sends text messages to a remote subscriber unit. To receive the data, the remote unit must have a 7041 Hand Held Programmer attached or be equipped with a terminal. The most common use for this function is to test the communications link by sending data packets.</li> </ul>
<p><b>REQUEST STATUS</b></p> <ul style="list-style-type: none"> <li>• Press &lt;ALT&gt;+&lt;R&gt; or &lt;ALT&gt;+&lt;M&gt;, then &lt;2&gt;</li> <li>• Select Target Unit</li> <li>• Press &lt;ENTER&gt; for route</li> </ul>	<ul style="list-style-type: none"> <li>• Queries a remote unit for its current status, requiring a "check-in" report back to the central station. The resulting return message provides the current status of the remote unit <i>and</i> sends a status (check-in) message to the alarm automation port. (See the manual section on messages types and interpretations).</li> </ul>
<p><b>GET SUBSCRIBER ROUTE TABLE</b></p> <ul style="list-style-type: none"> <li>• Press &lt;ALT&gt;+&lt;G&gt; or &lt;ALT&gt;+&lt;M&gt;, then &lt;4&gt;</li> <li>• Select Target Unit</li> <li>• Select Route</li> </ul>	<ul style="list-style-type: none"> <li>• Queries a remote unit for its current routing table. It prints the routing table for this subscriber, and displays the routing table from top (best) to bottom. For each unit on the list, the following items are displayed: <ul style="list-style-type: none"> <li>• ID #</li> <li>• LINK LAYER # • NETCON</li> </ul> </li> <li>• SIGNAL QUALITY between this unit and queried unit, listed as Good, Fair or Poor</li> </ul>
<p><b>GET ALL SUBSCRIBER DATA</b></p> <ul style="list-style-type: none"> <li>• Press &lt;ALT&gt;+&lt;M&gt;, then &lt;5&gt; or Press &lt;ALT&gt;+&lt;L&gt;</li> <li>• Select Target Unit</li> <li>• Select Route</li> </ul>	<ul style="list-style-type: none"> <li>• Queries a remote unit for ALL of its currently programmed parameters. The function automatically performs all the Get functions, retrieving Timing, Zones, Model #/Rev and Mode data for the unit you specify. (See specifics below).</li> </ul>
<p><b>(GET) SUBSCRIBER TIMING DATA</b></p> <ul style="list-style-type: none"> <li>• Press &lt;ALT&gt;+&lt;M&gt;, then &lt;6&gt; or Press &lt;ALT&gt;+&lt;I&gt;</li> <li>• Select Target Unit</li> <li>• Select Route</li> </ul>	<ul style="list-style-type: none"> <li>• Queries a remote unit for its current timing parameters. The received data updates the timing parameters database. Timing parameters are part of the Programming Function Group described in the following pages.</li> </ul>
<p><b>(GET) SUBSCRIBER ZONES DATA</b></p> <ul style="list-style-type: none"> <li>• Press &lt;ALT&gt;+&lt;M&gt;, then &lt;7&gt; or Press &lt;ALT&gt;+&lt;Z&gt;</li> <li>• Select Target Unit</li> <li>• Select Route</li> </ul>	<ul style="list-style-type: none"> <li>• Queries a remote unit for its current zone configurations. The received data updates the Zone Configuration database. The Zone Configuration is part of the Programming Function Group described in the following pages.</li> </ul>

<p><b>(GET) SUBSCRIBER MODEL &amp; REV</b></p> <ul style="list-style-type: none"> <li>• Press &lt;ALT&gt;+&lt;M&gt;, then &lt;8&gt; or Press &lt;ALT&gt;+&lt;E&gt;</li> <li>• Select Target Unit</li> <li>• Select Route</li> </ul>	<ul style="list-style-type: none"> <li>• Queries a remote unit for its model number (e.g. 7750F, 7450, 7050E, etc.) and its firmware revision number. This information is stored in the database.</li> </ul>
<p><b>(GET) SUBSCRIBER MODE DATA</b></p> <ul style="list-style-type: none"> <li>• Press &lt;ALT&gt;+&lt;M&gt;, then &lt;9&gt; or Press &lt;ALT&gt;+&lt;O&gt;</li> <li>• Select Target Unit</li> <li>• Select Route</li> </ul>	<ul style="list-style-type: none"> <li>• Queries a remote unit for the current "mode" settings (enable/ disable) for 3 different parameters: <ul style="list-style-type: none"> <li>• IntelliTap Message, default = enabled (works with 7050-E (Ver 2+), 7750-F, 7450, 7440 only)</li> <li>• Subscriber Repeater Function, default = enabled (works with all units except 7440, which do not repeat)</li> <li>• Telephone Line Cut Function, default = disabled (works with 7450, 7440 only)</li> </ul> </li> </ul>
<p><b>(GET) SUBSCRIBER PACKET LIFE SETTINGS</b></p> <ul style="list-style-type: none"> <li>• Press &lt;ALT&gt;+&lt;M&gt;, then &lt;A&gt; or Press &lt;ALT&gt;+&lt;N&gt;</li> <li>• Select Target Unit</li> <li>• Select Route</li> </ul>	<ul style="list-style-type: none"> <li>• Queries a remote unit for its Packet Life Settings (aka Time-to- Live or TTL). This function can only be used with Version 2+ subscribers with TTL capability. Other are not supported. This information is stored in the Net software database.</li> </ul> <p>See also - Radio Packet Life Parameters, Programming Menu.</p>

## 11.6 Control Function Group



*Figure 11-7 Control Pull down Menu*

To access the Control function menu group, hold down the <Alt> key and Press <C>. The pop-up illustrated above will appear. Use the arrow keys to highlight a control function and press <Enter> to select it. Proceed by selecting your target unit and choosing a route of communication.

## Explanation of the Control Group Functions:

Function	Explanation
<b>TURN ON TX</b> <ul style="list-style-type: none"> <li>• Press &lt;ALT&gt; + &lt;C&gt;</li> <li>• Press &lt;1&gt;</li> <li>• Select Target Unit</li> <li>• Select Route</li> </ul>	<ul style="list-style-type: none"> <li>• Re-enables transmitting on a remote subscriber unit that has been turned off (see Turn Off TX, next).</li> </ul>
<b>TURN OFF TX</b> <ul style="list-style-type: none"> <li>• Press &lt;ALT&gt; + &lt;C&gt;</li> <li>• Press &lt;2&gt;</li> <li>• Select Target Unit</li> <li>• Select Route</li> </ul>	<ul style="list-style-type: none"> <li>• Disables a remote subscriber unit should the need arise, such as when an alarm system fails and causes the transmitter to activate repeatedly. <b>NOTE:</b> The unit is not literally turned off, but is prevented from transmitting until it receives the "Turn On" signal (above). Also Note that a transceiver in the Off Mode will create route failed message when including in an outbound route.</li> <li>• A reset will clear this mode and return to TX ON.</li> </ul> <p>WARNING: This function disables the subscriber - use it only when absolutely necessary.</p> <ul style="list-style-type: none"> <li>• This function may be used on UL Burglar Alarm and Fire Alarm systems only with strict adherence to the requirements of UL Standard 611, Central Station Burglar Alarm Units and the National Fire Alarm Code, NFPA 72.</li> </ul>
<b>REMOTE RESET</b> <ul style="list-style-type: none"> <li>• Press &lt;ALT&gt; + &lt;C&gt;</li> <li>• Press &lt;3&gt;</li> <li>• Select Target Unit</li> <li>• Select Route</li> </ul>	<ul style="list-style-type: none"> <li>• Resets the remote subscriber unit - the same as physically pushing the reset button on the unit itself. This causes the subscriber unit to re-enroll on the network and build a new routing table. A reset may be used to restart the check-in interval timer. The new interval will commence at the time of reset (see also: subscriber unit manuals).</li> </ul>
<b>INTELLITAP MESSAGES</b> <ul style="list-style-type: none"> <li>• Press &lt;ALT&gt; + &lt;C&gt;</li> <li>• Press &lt;4&gt;</li> <li>• Select Target Unit</li> <li>• Select Route</li> <li>• Enter D to Disable, E to Enable Tap Messages</li> </ul>	<ul style="list-style-type: none"> <li>• Enables / Disables the subscriber unit's ability to send IntelliTap Messages. CAUTION: Once disabled, the subscriber will ignore IntelliTap or FDX data presented to its port.</li> <li>• This function works with 7750-F, 7050-E (Ver 2+), 7450 and 7440 models.</li> <li>• To confirm the function, perform a "Get Subscriber Mode Data" to retrieve the current status of this mode (Message group, # 9) and to update the database.</li> <li>• Refer to subscriber unit and IntelliTap manuals for more information.</li> </ul>



**SUBSCRIBER  
REPEATER FUNCTION**

- Press <ALT> + <C>
- Press <5>
- Select Target Unit
- Select Route
- Enter D to Disable, E to Enable Repeating

- Enables / Disables the subscriber units ability to be a repeater.
- Works with Version 2 or higher subscriber units.

CAUTION: Disabling the repeater capability may cause problems with the network. Disable repeating for testing purposes only, or for mobile units, which are never to be used as repeaters.

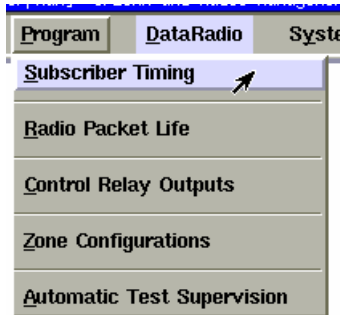
- To confirm the function and update the database, perform a "Get Subscriber Mode Data" to retrieve the current status of this mode (Message group, # 9)
- Refer to subscriber unit manuals for more information.

**TELEPHONE LINE  
CUT FUNCTION**

- Press <ALT> + <C>
- Press <6>
- Select Target Unit
- Select Route
- Enter D to Disable, E to Enable Line Cut Monitoring

- Enables / Disables the Phone Line Cut Monitoring function in 7450 or 7440 subscriber units.
- To confirm the function and update the database, perform a "Get Subscriber Mode Data" to retrieve the current status of this mode (Message group, # 9)
- Refer to 7450 or 7440 subscriber unit manuals for more information.

## 11.7 Programming Function Group:



*Figure 11-12 Program Pull Down Menu*

To access the Programming function menu group, hold down the <Alt> key and Press <P>. The pop-up illustrated above will appear. Use the arrow keys to highlight a function and press the <Enter> to select it. Proceed by selecting your target unit, choosing a route of communication and then editing the presented form.

### Explanation of the Program Group Functions:

Function	Explanation
<p><b>SUBSCRIBER TIMING</b></p> <ul style="list-style-type: none"> <li>• Press &lt;ALT&gt; + &lt;P&gt;</li> <li>• Press &lt;S&gt;</li> <li>• Select Target Unit</li> <li>• Select Route</li> <li>• Edit form as necessary</li> </ul>	<p>Enter Address            Check-In interval 0..24 Hrs:            Secondary Alarm Delay:            Contact Debounce Time:            Acknowledge Delay:            See below for details on data entry for this function:</p>

### Subscriber Programming – Data Entry Screen:

*Figure 11-13 Timing Parameters Data Entry*

The form illustrated above allows an operator to change the timing parameters of a Subscriber unit using the IPCtrl software. When the programming window appears, the fields will usually be pre-filled with values. If there is a database entry for the selected Subscriber, the values

will be retrieved from there. If no database entry exists, the factory defaults will be used.

**To be sure that the pre-filled values represent the current settings in the Subscriber, it is recommended that you retrieve the current parameters from the Subscriber before you edit and send new values.** See “[Get All Subscriber Data](#)” under the [Message Function Group](#) earlier in [section 11](#).

- **Enter Address:** Freeform field to put location reference information. This is stored in the database and is not sent to the Subscriber.
- **Set Check-In Interval (Automatic Test):** When the Subscriber Programming screen appears, a cursor will be flashing at the check-in interval area. The intervals can be programmed between one minute and 24 hours (the default setting is at 24 hours). To minimize radio air traffic, an interval of 24 hours is recommended except in high security applications. The ability to change this timing feature by remote is a key advantage of the two-way **AES•IntelliNet** system. When you have entered a check-in time interval, press <Tab> to move on to the next field. When done, click [OK] press to send parameters to Subscriber and update the database.
- **Secondary Alarm Delay (Additional Event Report Delay):** This feature allows a subscriber unit to accumulate alarms, after its initial alarm report, for a programmed time period. When an alarm has occurred at a remote subscriber site, the central receiver is notified immediately. The event report delay allows a remote unit to compile subsequent alarms for a period of time, so that a comprehensive packet of alarm data is sent to the **IntelliNet** system all at once, thereby reducing network airtime. This delay also prevents a subscriber from attempting to monopolize the airtime by having it wait between transmissions. The default setting for this feature is 10 seconds. To change the event report delay, enter the new value and press <Tab> to move to the next field.

**A delay of less than 10 seconds is not recommended.**

• **Contact Debounce Time**

(Loop Response) 7050 & 7750/UL only: Programs a debounce delay for the zone inputs of 7050 and 7750/UL subscriber units to prevent input switches or relays from causing nuisance alarms and repeated reports of the same alarm. The default setting is 0.12 seconds. If you choose to change this setting, simply enter the new value and press <Enter> to move to the next field. ***A control unit (panel) output(s) to the 7750 RF subscriber unit shall be programmed to latch in when it triggers a zone input on the 7750.***

*Note: The contact debounce time in the 7050-E, 7440, 7450, 7750-F4x4 and 7750-F8 units are preset at 0.12 seconds and cannot be changed.*

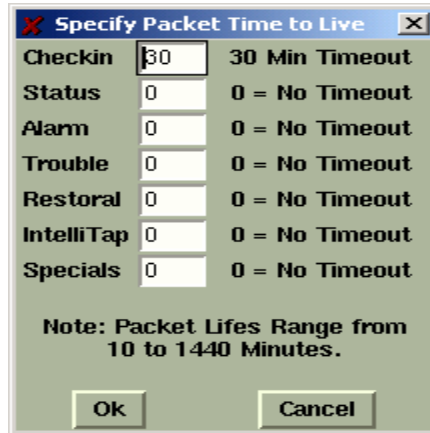
• **Acknowledgment Delay:** If a subscriber unit does not receive an acknowledgment (Packet Acknowledge) within the time parameters set by the Acknowledgment Delay parameter, it activates an output to annunciate the problem locally. The next successful communication to the central station will include an ACK Delay fault code. The default setting for this feature is 90 seconds. If you choose to change the ACKnowledgment DELAY period, simply type in the new value. Click [OK] to complete and send your timing parameter data.

**For 7750/UL, 7750-F4x4 and 7750-F8 Subscriber Units:** A zone of the control panel shall be connected to the relay labeled "ACK DELAY", to monitor the subscriber unit against antenna removal, communication failure and to provide a local and remote annunciation of such a fault condition. (Refer to subscriber manuals.)

**NOTE:** *For all remote program functions, watch to make sure that a data confirmation packet is received from the target subscriber (watch scrolling message screen area).*

Function	Explanation
<b>RADIO PACKET LIFE</b> <ul style="list-style-type: none"> <li>• Press &lt;ALT&gt; + &lt;P&gt;</li> <li>• Press &lt;R&gt;</li> <li>• Select Target Unit</li> <li>• Select Route</li> <li>• Edit form as necessary</li> </ul>	See below for details on data entry for this function:

**Radio Packet Life – Data Entry Screen:**



*Figure 11-14*  
Radio Packet Life

Version 2.1 subscribers include the “Time-To-Live” (TTL) function. Like the Internet, **AES•IntelliNet** uses a packet-based technology. The Time-to-Live concept in the Internet is based on the fact that all data has a useful life.

The benefits of TTL are best exhibited when the IP-Link goes off line due to a lightning hit or some other unlikely, catastrophic event. While the IP-Link is off line, messages traveling through the system are stored in the individual subscriber units for later delivery. Under the default TTL settings unimportant test timer message (typically 95+% of the traffic) are deleted from the subscriber unit memory after 30 minutes of being delayed in the network. Thus, the system will not have to handle the message when the IP-Link Receiver comes back on line. All other messages, such as alarm, etc. speed their way to the IP-Link as they normally do.

**UL864 requires a setting of 0 for Alarm, Trouble and Restoral.**

- Note that even when a check-in packet is deleted due to a delay, the objective of that message has already served its purpose: the late or missing signal should have been flagged at the central station (see Automatic Test Supervision section).
- Under the default (factory) settings, only test timer messages are subject to the TTL function. If you want TTL for other message types, YOU must activate it when you program the subscriber unit.
- The TTL time is included in packets generated by TTL capable Subscribers. This feature is available in Subscribers with firmware Version 2.1 and later which was first released in late 2000.

- The timeout function works when a packet is stored for forwarding in any subscriber with TTL capability, which will decrement the TTL time for the packet it is storing. When TTL time has expired, the packet is aborted. This function does not work with non-TTL (pre-Version 2.1) subscribers. The TTL feature works best when the majority of subscribers, or the subscribers that are most heavily used, have the feature in the firmware. Call your AES representative for upgrade information. Default time for Check-In Packets is 00 hours, 30 minutes. DO NOT enter a greater than 24 hrs 00 mins. Entering a time of 00 hours and 00 minutes deactivates the time-to-live function for that packet type. The shortest allowed TTL time is 00 hours, 10 minutes. TTL can also be set for other packet types:

- Zone Alarm Packets
- Status Packets
- Zone Restoral Packets
- AES-IntelliTap Packets
- Trouble / Trouble-Restoral Packets

The default time for the 6 packet types above is 00, i.e. the time-to-live function is deactivated for these packets. Entering anything greater than 00 HRS and 10 MINS will enable the Time-to-Live function. Enter the data for each type, click [OK] to send.

To confirm the data, press <Alt>+<N> to query the subscriber for Packet Life settings. When the TTL parameters packet has been received back, check this screen again.

[See - Get Packet Life Settings, Message Functions Group](#)

## Function

## Explanation

### CONTROL RELAY OUTPUT

- Press <ALT> + <P>
- Press <C>
- Select Target Unit
- Select Route
- Edit form as necessary

See below for details on data entry for this function:

### Control Relay Output – Data Entry Screen:

This feature controls optional relay outputs (part number 7065) for model 7050 Subscribers units. Using this remote control capability, an operator may open gates, activate cameras or control any devices at a remote location. The basic relay output uses eight relays, but as many as 64 may be controlled.

### Relay Programming Window

1	2	3	4	5	6	7	8	9	10	11	12	13	14	15	16
0 ↑	0 ↑	0 ↑	0 ↑	0 ↑	0 ↑	0 ↑	0 ↑	0 ↑	0 ↑	0 ↑	0 ↑	0 ↑	0 ↑	0 ↑	0 ↑
17	18	19	20	21	22	23	24	25	26	27	28	29	30	31	32
0 ↑	0 ↑	0 ↑	0 ↑	0 ↑	0 ↑	0 ↑	0 ↑	0 ↑	0 ↑	0 ↑	0 ↑	0 ↑	0 ↑	0 ↑	0 ↑
33	34	35	36	37	38	39	40	41	42	43	44	45	46	47	48
0 ↑	0 ↑	0 ↑	0 ↑	0 ↑	0 ↑	0 ↑	0 ↑	0 ↑	0 ↑	0 ↑	0 ↑	0 ↑	0 ↑	0 ↑	0 ↑
49	50	51	52	53	54	55	56	57	58	59	60	61	62	63	64
0 ↑	0 ↑	0 ↑	0 ↑	0 ↑	0 ↑	0 ↑	0 ↑	0 ↑	0 ↑	0 ↑	0 ↑	0 ↑	0 ↑	0 ↑	0 ↑

OK Cancel

*Figure 11-15 Relay Control Menu*

Choose a number: 0 for Off, 1 for On or 2 for Toggle / Momentary and select [OK] to control Relays in a Subscriber equipped with appropriate module.

**Function**

**Explanation**

**ZONE CONFIGURATION**

- Press <ALT> + <P>
- Press <Z>
- Select Target Unit
- Select Route
- Edit form as necessary

See below for details on data entry for this function:

This function configures alarm zone inputs for a premise unit. It is important to know which type of unit is being programmed. There are separate sub-menus to handle the different subscriber units. The sub-menu that will be presented upon selection of a subscriber ID is based on the database entries. The subscriber model may be selected during setup in the Admin GUI and using the Get All function in the message group will update all fields required to identify the unit.

Subscriber models include:

7050/7750-UL (Version 1.8 or older)	7750
7050-E (Version 1.8 or older)	7750F 4X4
7050-E / F8 (Version 2.0 and newer)	

To access the Programming function menu group, hold down the <Alt> key and Press <P>. The Programming window illustrated below will appear. Select zone Configuration then [OK]. Proceed by selecting your target unit and choosing a route of communication.

Sample Zone Configuration windows for the various Subscribers are shown below.

**Fire/Inverted Fire programming notes:**

If the Subscriber type selected supports Fire and Inverted Fire programming, these notes apply to the programming sequence and the following questions will appear before the zone programming selection window.



*Figure 11-16*

The programming sequence first asks if any zones are to be programmed to respond similar to a "Fire circuit". This is not to be confused with the device usage, but rather how changes to the EOL will be reported. Click yes if you wish to have the zone report "Trouble" conditions on an open circuit and alarm on a short. Otherwise click No for alarm message to be reported on a short or open. A raised appearing button indicates the default or current programming, if it is stored in the database from a



previous programming or retrieval.

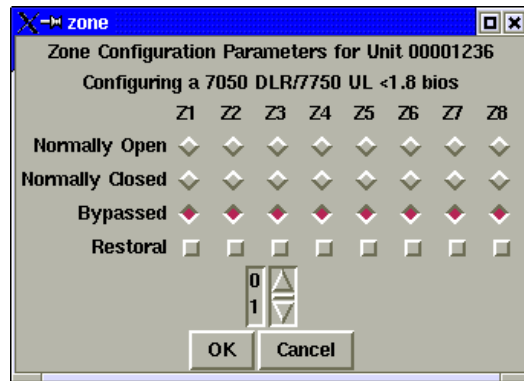
Next you are asked if any zones are to be programmed to respond similar to an "Inverted Fire circuit" or bugler loop. With this option you can select to reverse the logic for the fire input (refer to subscriber manual). This produces an alarm on an open and trouble on a short. If stored in the database, the current programming is displayed.

**IMPORTANT NOTES:**

- The zone programming options are limited. Of the 3 EOL zone types - Supervised, Fire and Inverted Fire, you can choose any 2.
- You can always choose Bypass and Restoral for any zone.
- Normally open and Normally Close are always available if they are an authorized option.

Next appears the zone configuration box, which displays the available options:

**Zone Configuration window for the 7050 DLR/7750 UL Bank 0**



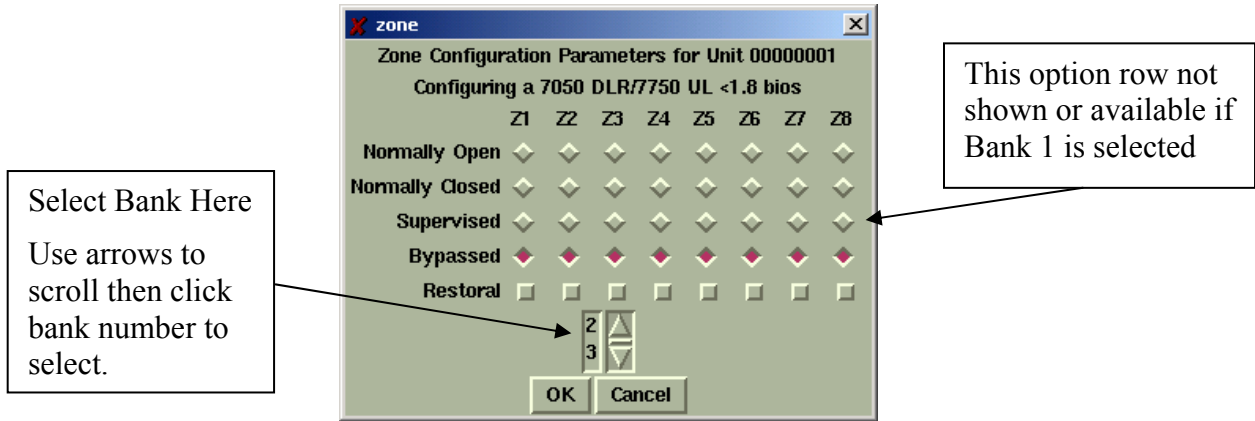
*Figure 11-17*

The zone configuration control block for zone 1-8 in Bank 0 offers five options for the programming of each alarm zone. Bank 0 is the 8 zones on the main board. Other banks are available if expansion module(s) are installed. Bank 0 does not support Supervised/EOL wiring or programming. Bank 2-8 shown next.

Normally Open	Normally Open with Restoral
Normally closed	Normally Closed with Restoral
Bypassed	

Use the mouse to select the appropriate boxes for the zone you wish to program. The numbers below the restoral row selects the bank. Scroll through the numbers using the arrows and then click the number to select that bank. The information in the window will change representing those zones.

**Zone Configuration window for the 7050 DLR/7750 UL Bank 1 - 8**



**Figure 11-18**

The zone configuration control block offers seven options for the programming of each alarm zone:

Normally Open	Normally Open with Restoral
Normally closed	Normally Closed with Restoral
Bypassed	Supervised (Not available on Bank 0, Zone 1-8)
Supervised with Restoral.	(Not available on Bank 0, Zone 1-8)

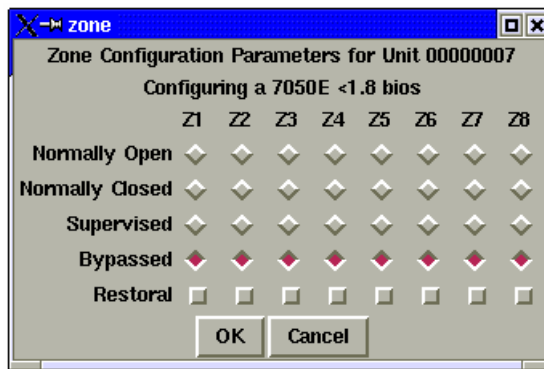
Use the mouse to select the appropriate boxes for the zone you wish to program. Banks 1-8 support Supervised programming and wiring.

UL and COMMERCIAL FIRE INSTALLATION REQUIREMENTS for 7750/UL Subscriber Units:

- **Zones 1-6:** Bypassed
- **Zone 7:** N.O. w/Restoral–Tamper (creates N.C. loop through zone 7 of 7072 module)
- **Zone 8:** N.O. W/Restoral – AC Fail (from 7072 multi-board)

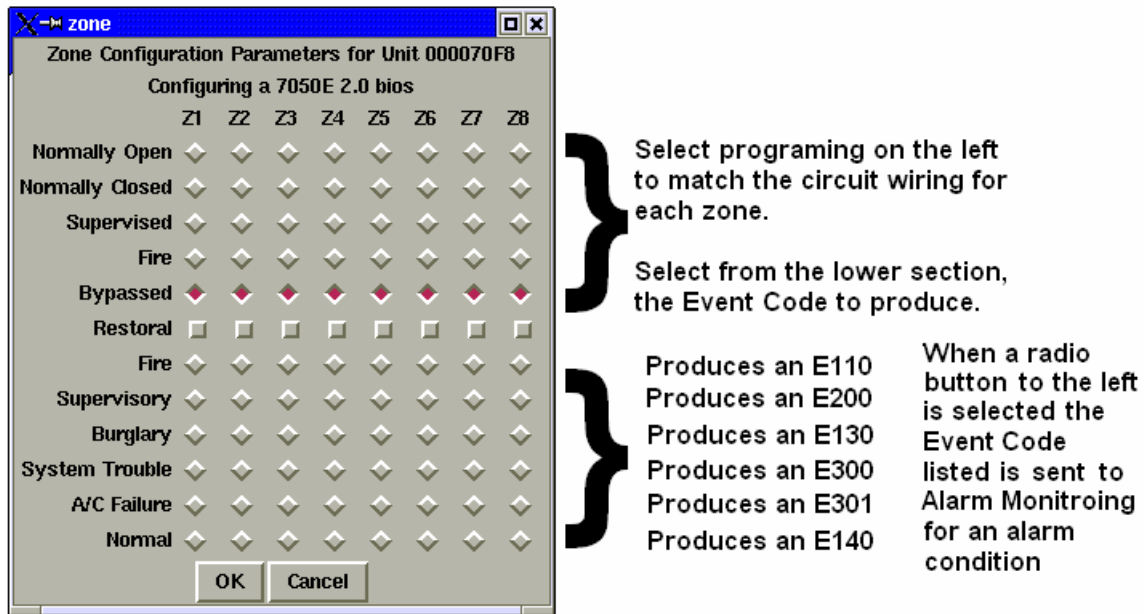
*Refer to Subscriber Unit Manual for details on zone wiring and programming.*

**Zone Configuration window for the 7050E Rev 1.8 and older**



**Figure 11-19**

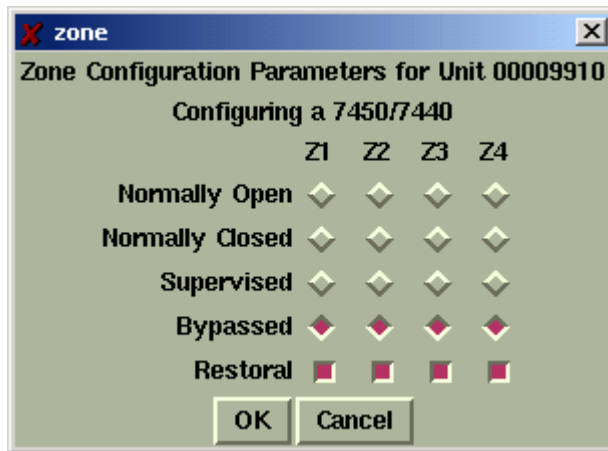
## Zone Configuration window for the 7050E, 7750/F8 and 7788



*Figure 11-20*

In this Subscriber type, the user has the ability to select an optional Contact ID Event Code to be sent to the Alarm Monitoring System for each of the 8 zones. The former standard produced only an E140, which is typically listed as a General Alarm. Select normal to have an E140 sent to alarm monitoring.

## Zone Configuration window for the 7450/7440



*Figure 11-21*

### Zone programming window for the 7750-F4x4 and 7744

Refer to the appropriate Subscriber Manual for details on zone writing and programming.

This screen below appears if the unit zone information is in the database.

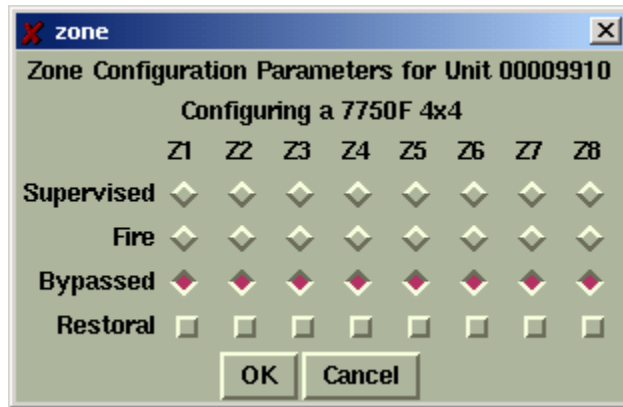


Figure 11-22

The Zone configuration pop-up window offers the following options for the programming of each alarm zone.

Supervised	Fire
Restoral with Supervised or Fire	Bypassed

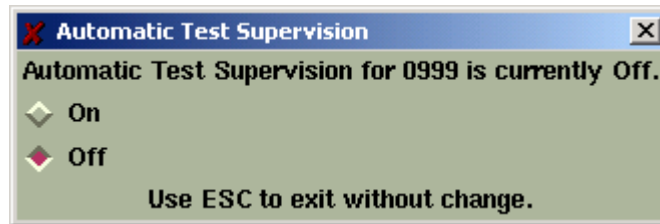
Function	Explanation
<b>AUTOMATIC TEST SUPERVISION</b> <ul style="list-style-type: none"> <li>• Press &lt;ALT&gt; + &lt;P&gt;</li> <li>• Press &lt;A&gt;</li> <li>• Select Target Unit</li> <li>• Edit form as necessary</li> </ul>	See below for details on data entry for this function:

**Automatic Test Time Supervision – Data Entry Screen:**

This feature enables the IPCtrl software to monitor automatic test timer check-ins. When enabled, it alerts an operator if a subscriber unit fails to report in within the programmed interval, plus 10% + 2 minutes as programmed in the subscriber’s timing Parameters function.

A missed Check-In is reported to alarm automation if enabled. See [Appendix E](#) for generated messages.

Access this function from the Program pull down menu. Select the Automatic Test Supervision or Press <Alt> +<P>, then **A**. Select the Unit to be supervised and the following window appears.



*Figure 11-23  
Automatic Test  
Supervision*

Select On or Off radio button to configure this function.

Note: Enabling supervision function suppresses Check-In messages from being sent to automation. Only exceptions are reported.

## 11.8 Data Radio Function Group:

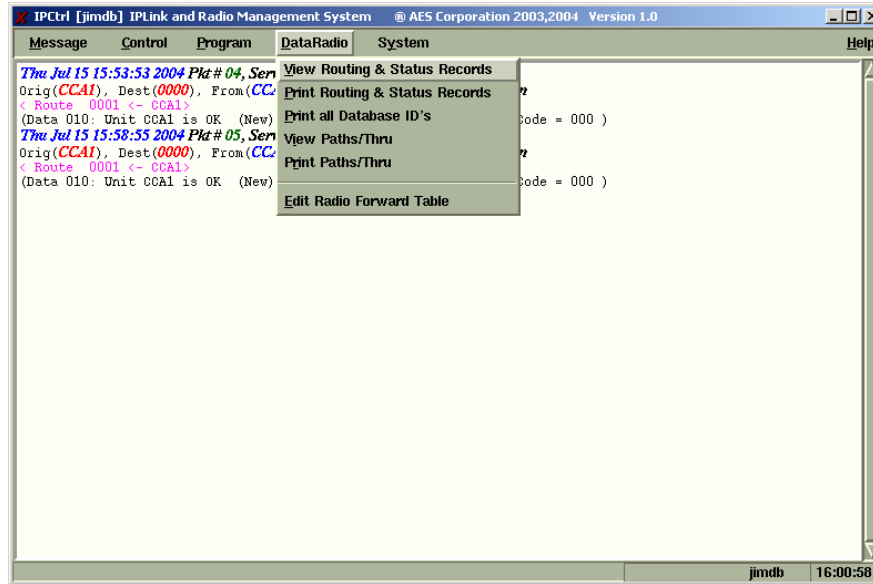


Figure 11-24

To access the DataRadio function group, hold down the <Alt> key and press <D>. The Pop-up screen illustrated at above will appear. Select a function. Proceed by selecting your target unit.

### Explanation of the DataRadio Group Functions:

Function	Explanation
<b>VIEW ROUTING &amp; STATUS RECORDS</b> • Press <ALT> + <P> • Press <V> • Select Target Unit	This function views on the screen the Routing & Status Records of the selected ID.  See below for an example:
<b>PRINT ROUTING &amp; STATUS RECORDS</b> • Press <ALT> + <P> • Press <P> • Select Target Unit	This function prints on the printer, the Routing & Status Records of the selected ID.  Information is similar to example below:

An illustration similar to below will appear for view. Similar information is sent to the printer if Print is selected.



Figure 11-25

It Displays the routing record and current status of the selected Subscriber unit.

All UL Burglar Alarm and Commercial Fire Alarm Systems require a minimum of 2 paths.

Function	Explanation
<p><b>PRINT ALL DATABASE ID's</b></p> <ul style="list-style-type: none"> <li>• Press &lt;ALT&gt; + &lt;P&gt;</li> <li>• Press &lt;P&gt;</li> <li>• Click function</li> <li>• View available data</li> </ul>	<p>This function sends a listing of all ID's that are in the Database to the printer port.</p>
<p><b>VIEW PATHS/THRU</b></p> <ul style="list-style-type: none"> <li>• Press &lt;ALT&gt; + &lt;P&gt;</li> <li>• Press &lt;I&gt;</li> <li>• Select Target Unit</li> <li>• View available data</li> </ul>	<p>This function displays a list of Units that are “routed through” the selected unit.</p> <p>This is important for demonstrating that a unit has multiple paths available.</p> <p>It is also important to help determine the effect a Subscriber will have if removed.</p>
<p><b>PRINT PATHS/THRU</b></p> <ul style="list-style-type: none"> <li>• Press &lt;ALT&gt; + &lt;P&gt;</li> <li>• Press &lt;R&gt;</li> <li>• Select Target Unit</li> <li>• View available data</li> </ul>	<p>Same View as above except that the information is sent to the printer instead of the screen.</p>

**View Paths/Thru window:**



*Figure 11-26*

Function	Explanation
<p><b>EDIT RADIO FORWARD TABLE</b></p> <ul style="list-style-type: none"> <li>• Press &lt;ALT&gt; + &lt;P&gt;</li> <li>• Press &lt;E&gt;</li> </ul> <p>Select / Enter Origin Unit ID</p> <ul style="list-style-type: none"> <li>• Edit form as necessary</li> </ul>	<p>Forwarding is a function that causes the IPCtrl software to transmit a data packet to a remote Subscriber upon the reception of a specific event by the same or another Subscriber.</p> <p>See below for details on data entry for this function:</p>

**Edit Radio Forward Table:**

*Figure 11-27*

The Forwarding table above is used to configure the event and subscriber to forward the data to. The types of outbound data packets include data to be printed on a serial printer attached to the remote subscriber's serial port, alarm automation messages and instructions to control relays on an attached Relay Output module.

Caution! Forwarding increases air traffic on the network, which may lead to slowdowns on a busy system. Use forwarding sparingly and only when required. Only forward essential data.

- There is no guarantee the for-warded data will be received. The remote site that receives the data is not a substitute for a central receiver. There will be no notification or report to any external system if a forwarded packet fails to reach the destination Subscriber.
- IPCtrl software can forward the activity data of a subscriber unit to another subscriber unit. The data received is sent to the RS-232 port of the receiving unit, where a handheld programmer (terminal), a printer or a computer may be connected. This allows a secondary site to monitor alarms, restorals check-ins, etc. at a secondary location. This function is for secondary reporting only - the central receiver is always the primary monitoring site.
- Select or Enter the Origin ID. Then enter the ID of the unit data is to be forwarded to.
- Add a memo (such as name/address) of up to 40 characters. This memo is sent with all forwarded data.



- Select ALARM and/or ZREST plus desired Zones if Forwarding Alarm data is the objective.
- Select as desired any other type of data or feature that you want forwarded. The following options are available: In some cases the only information forwarded is a message indicating that a packet of the selected type was sent and not the data itself,
  - STAT → Subscriber Status**
  - CHKIN → Check-In**
  - DATA**
  - HPBU → Programming Uploads**
  - TEST Data**
  - ZDATA → Zone Data**
  - VLS → Vehicle Location Data**
  - TEXT → Text Message**
- Other Options: The following additional features can be activated for forwarding. These require specific units and capabilities at the Forwarded to site to be accepted and properly handled.
  - **Alarm Automation Message:** Alarm activity can be transmitted to the remote unit in Alarm Automation Format. The RS-232 output of a special "FA" or "FAA" 7050-DLR receiving unit can feed alarm data directly to a computer running automation software. Sending these specially formatted packets to a subscriber that is not intended to receive it will cause the packet to be rejected.
  - **Relay Following:** This special function requires the Forward-To unit to be a 7050-DLR subscriber unit with a 7065 Relay Output board installed. When programmed for forwarding with relay following and a zone in alarm message is received from the origin unit, a relay control command is sent to the receiving unit to activate a relay. Zone 1 in the origin unit trips relay 1 in the forward-to unit, zone 2 trips relay 2, and so on.
    - For 7050 version 2 and later, the relay is momentarily activated for 1 second. Be aware that the relay may activate more than one time but should always return to a Normally Open State
    - r 7050 version prior to 2 the relay is toggled. Be aware that you cannot be sure if the relay will be left open or closed. Only that it will change state at least once.

## 11.9 System Function Group

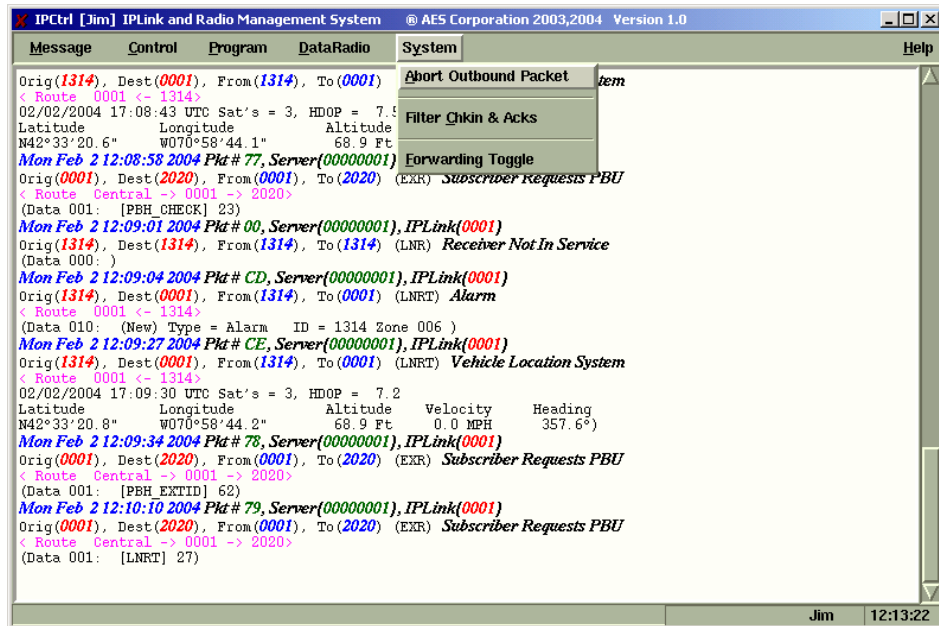


Figure 11-28

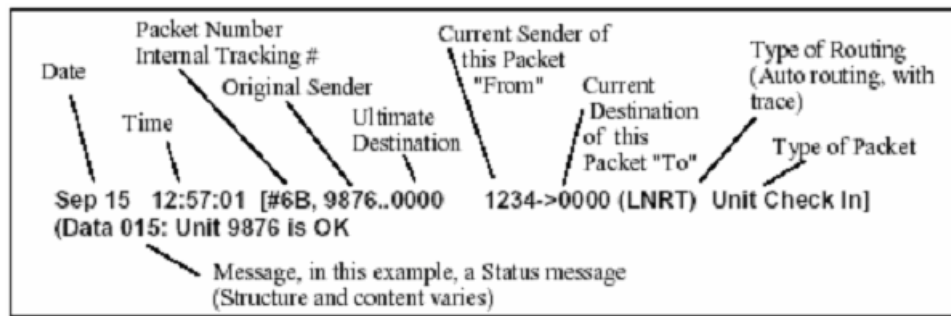
The Systems Function group menu is accessed by holding <Alt> and pressing <Y>. This group contains functions related to the operation on the software.

### Explanation of the System Group Functions:

Function	Explanation
Abort Outbound Packet	<ul style="list-style-type: none"> <li>Quickly cancels an unacknowledged packet sent to a subscriber unit by the receiver. This includes "Get" query functions.</li> </ul>
Filter Check-In & ACKS	<ul style="list-style-type: none"> <li>To filter out screen "clutter", this function prevents non-critical check-in messages from appearing on the screen. This is a "toggle" function.</li> </ul>
Forwarding Toggle	<ul style="list-style-type: none"> <li>This one command allows you to globally enable or disable the forwarding function. It affects only those units that have been programmed for forwarding. (For more information, see the section on Database Group / Edit Radio Forward Table.) A pop up window shows you the current status global forwarding (On or Off). Enter Y/yes or N/no to change the status.</li> </ul>

## 11.10 Interpreting Screen Messages

SAMPLE Check-In Message:



The following information can be extracted from the sample message above:

The message was received on September 15<sup>th</sup> at 12:57:01

The sequential packet number assigned to this packet is 6B

The message originated at subscriber unit #9876, and its destination is Unit #0000 (the head end)

Subscriber #1234 – a “repeater” in the message path, is sending the specific message

This specific message is being sent to Unit #0000 (the designation for the central station receiver)

This is a Unit Check-In / Automatic Test Timer message. It indicates that all is well

The type of routing used:

(LNRT) - Layered Net Routing with Trace, which means automatic routing with trace.

Trace means the path of the packet is being tracked from origin to destination.

This information will be stored in the database

(LNR) - Layered Net Routing without Trace

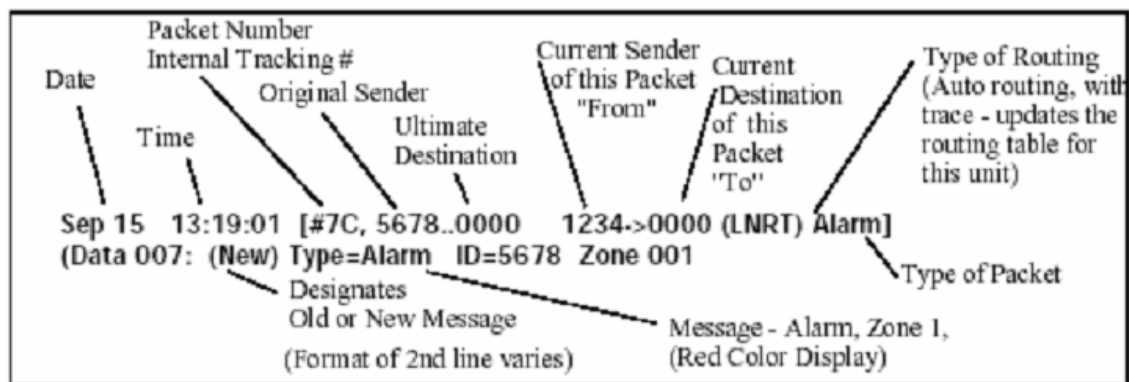
(EXR) - an operator specified or the software selected explicit routing.

“Data” refers to the data attached or included with this communication. The number after the word Data indicates the length in Bytes of data included. After the length the data may or may not be displayed and can be in easily readable or in a raw or Hex computer format if shown at all. In this case, the 15 bytes of data indicate that the unit is OK.

The ID of the unit transmitting this packet is listed before the “->”

The ID of the unit this packet it is being transmitted to is listed after the “->”.

SAMPLE Alarm Message:



The following information can be extracted from the sample message above:

The message was received on September 15<sup>th</sup> at 13:19:01

The sequential packet number assigned to this packet is 7C

The message originated at subscriber unit #5678, and its destination is Unit #0000 (the head end)

Subscriber #1234 – a “repeater” in the message path, is sending the specific message to #0000.

The type of routing used is LNRT

This is an Alarm message. It is displayed in red for easy recognition

The 7 bytes of data indicate new alarm on the Subscriber’s Zone 1

## 12.0 Operation

This section describes two of the modes of operation your MultiNet Receiver may be in and how to operate it.

### 12.1 Manual Operation

#### **The MultiNet receiver defaults to Manual Operation when Alarm Automation is not in use**

Manual operation of the MultiNet receiver is a mode where alarm and other messages are not being sent to an Alarm Monitoring System. This would occur when the Alarm Monitoring System was offline, down or disconnected.

#### **Steps for Receiver operation when a MultiNet Receiver receives an alarm message that is not being sent to an alarm automation system:**

1. A waiting MultiNet Receiver receives a message from an IP-Link or detects an off normal condition.
2. A record of the event is printed on the attached printer.
3. The Alert Sounder activates.
4. The Alert LED illuminates.
5. The message is added to the LCD queue and displayed, if it is at the top of the queue.
6. The user may press the “Silence” button to stop the Alert Sounder.
7. The user must interpret and properly respond to the message displayed. Refer to Appendix E for guidance with interpreting the displayed messages.
8. Once the information on the display is no longer needed, the user can press the “Acknowledge” button to remove the message from the queue.
9. When the Acknowledge is accepted an acknowledge message is printed indicating which of the previously printed messages is being acknowledged. A tracking number is recorded to assist in locating it in the logs for future review.
10. If the message is not acknowledged within 30 seconds of a Silence Button press, the Alert Sounder is re-activated.
11. Once a message is acknowledged and removed from the queue, the next message in the queue is annunciated and displayed as described above. If no messages are in the queue, the MultiNet Receiver returns to its normal waiting mode.

### 12.2 Automatic Operation

Automatic operation of the MultiNet receiver is a mode where alarm and other messages are being sent to an Alarm Monitoring System. No user interaction is required at the Receiver as long as the Alarm Monitoring System properly acknowledges the messages.

## 13.0 Warranty and Service Procedure:

### AES CORPORATION

#### LIMITED PRODUCT WARRANTY AND TECHNOLOGY LICENSE

##### **LIMITED PRODUCT WARRANTY:**

AES Corporation (“AES”) warrants to the original purchaser that each AES Subscriber Product will be free from defects in material and workmanship for three (3) years from date of purchase and all other products purchased from AES including central station receivers and accessories will be warranted for one (1) year from the date of purchase. At no cost to the original purchaser for parts or labor, AES will repair or replace any AES Product or any, part or parts thereof which are judged defective under the terms of this Warranty.

Defective AES Products must be returned to AES directly, provided they are properly packed, postage prepaid. Or exchange may be made through any authorized direct factory representative for any AES Products that are judged defective under the terms of this Warranty. Improper or incorrectly performed maintenance or repair voids this Warranty. This Warranty does not cover replacement parts that are not approved by AES. This Warranty does not apply to any AES Product or any part thereof that has been altered in any way to affect its stability or reliability, or that has been subjected to abuse, misuse, negligence, accident or act of God, or that has had the serial number effaced or removed.

Certain AES Products are designed to operate and communicate with other specified AES Products and certain other specified products, systems or networks authorized or approved by AES, as identified in the applicable AES Product instructions. This Warranty does not apply to any AES Product that is used with any unauthorized or unapproved products, systems or networks, or that has been installed, applied or used in any manner, other than in strict accordance with AES instructions.

*AES makes no warranty, express or implied, other than what is expressly stated in this Warranty.* If the law of your state provides that an implied warranty of merchantability, or an implied warranty of fitness for particular purpose, or any other implied warranty, applies to AES, then any such implied warranty is limited to the duration of this Warranty.

AES cannot be aware of and is not responsible for the differing values of any property to be protected by its alarm reporting systems. This Warranty does not cover and AES shall not be liable for any defect, incidental or consequential, loss or damage arising out of the failure of any AES Product to operate.

Some states do not allow the exclusion or limitation of the durations of implied warranties or the limitation on incidental or consequential damages, so the above limitations or exclusions may not apply to you.

This Warranty gives you specific legal rights and you may also have other rights that vary from state to state.

##### **TECHNOLOGY LICENSE:**

Certain AES Products include software, protocols and other proprietary and confidential technology and trade secrets of AES, which are incorporated in or provided, with AES Products solely for use in conjunction with and in order to operate AES Products (“Licensed Technology”). AES grants the original purchaser a non-exclusive license to use such Licensed Technology solely in connection with the use and operation of AES Products and for no other purpose or use whatsoever. No title or ownership in or to any such Licensed Technology is conveyed by the sale or delivery of any AES Products; all such rights are retained by AES.

**AES SERVICE PROCEDURE:** Contact AES at (978) 535-7310, [fax (978) 535-7313] to receive a Return Authorization Number. Have the AES part number and serial number ready. Repack equipment in original or equivalent packaging. Inside the box, please include a contact name, telephone number, address and a brief description of the reason for return.

**Ship authorized RA items freight-prepaid to:**

Repair Services, RA# \_\_\_\_\_

AES Corporation

285 Newbury Street

Peabody, MA 01960 USA

(call for Return Authorization number)



# APPENDICES

# Appendix A

## Common Linux Commands

Below are some of the more common commands you will be using on the Linux operating system:

**cat:** concatenate files and print on standard output. Ex: cat {filename}<Enter>  
**cd:** change directory  
**clear:** clear the screen.  
**cp:** copy files  
**grep:** find lines matching a certain pattern. Ex: grep {string} {filename}<Enter>  
**ifconfig:** displays current TCP/IP settings.  
**less:** filter for viewing files and directories. Ex: less {filename}<Enter>  
**locate:** locates files that matches a certain pattern. Ex: locate {filename}<Enter>  
**ls:** list: directory contents  
**mcopy:** copy files to a disk DOS. Ex: mcopy {filename} {destination ie a:}<Enter>  
**mdir:** list directory contents on a DOS contents.  
**mkdir:** make a new directory  
**passwd:** change a user password.  
**ping:** used to test IP connection to another node on the network.  
**ps:** display a process status.

Below are some advanced commands not commonly used or needed but could be useful for advanced users. Use caution with some of these as incorrect usage could cause a file or system to be modified and stop normal operation.

**etc:** system configuration file.  
**date:** used to set the time and date of the server. It is very important that time between multiple MultiNet Receivers be synchronized. Type **man date**<Enter> for usage information.  
**find:** find files.  
**halt:** shut down system  
**host:** look up host information.  
**hostname:** display system's hostname.  
**mv:** move or rename files.  
**reboot:** to reboot the computer.  
**root:** the user that owns the operating system and control the computer  
**setup:** A "Text Mode Setup Utility" that can be used to configure the system including time zone, network settings, keyboard, mouse, printer to name a few.  
**shutdown -h now:** to stop or halt the computer now.  
**shutdown -r now:** to reboot the computer now.  
**which:** display a program's executable path  
**whereis:** locate binary, sources and manual pages for a command.  
**who:** show the users who are logged in  
**whoami:** show the users who you are currently logged in as.  
**tzselect:** To set the time zone where the MultiNet receiver is located.

## Appendix B

### Server-generated LCD Display Messages.

#### Top line description:

The LCD is a 4-line display with 20 characters per line. It shows messages for the 7705i. Use this in conjunction with the Alert panel to interpret and acknowledge messages. There is also a tactile response sounder to provide audible confirmation of successful button activation.

In most modes of operation, the top line will be constant and usually displays the LCD firmware version number and AES copyright.

Example: Top line.

#.## (C)2005-06 AES
---------------------

#### Bottom 3 lines description:

The remaining 3 lines will display messages generated by the server as outlined below.

**Default Message:** When no alarm, restoral, status or failure messages are being displayed, and automation is on line, a default message will be displayed on the LCD that includes the version of the LCD Firmware, and the date and time.

#.## (C)2005-06 AES
---------------------

LCD #.##
----------

07/07/06 12:19
----------------

Default Example:

**Alarm, Restore and Status messages:** All alarm, restore and status messages that are to be sent by the server to alarm automation, will be sent to the LCD when the alarm automation system is off line. Following is what occurs when a message of this type needs to be displayed.

1. The message sent to the LCD will include the message to be sent to alarm automation, plus a simple human readable interpretation of the alarm that will include zone, group, etc. The LCD message will also include a timestamp and a count of pending alarms in the queue. See [Appendix E](#) for messages.
2. The Alert LED in the Alert Panel will be turned on if it is off. This will cause the Alert Buzzer to sound.
3. The Alert Buzzer is tied to the turning on/off of the Alert LED. It will sound upon the Alert LED being turned on or off. It will sound until the SILENCE button is pressed.
4. If the alarm is not acknowledged within 30 seconds after a silence, the buzzer sounds again.
5. Once acknowledged, the message will be removed from the display and replaced with the next message in the queue. If the next message is not an alarm, the alert LED will be turned off. Display will return to normal if no off-normal messages are to be displayed.
6. The database will be updated to indicate a manual acknowledgment for the alarm.
7. The alarm and the acknowledgment will be printed.
8. As the next message is displayed, a short tactile beep sounds as feedback that the ACKNOWLEDGE button was pressed.



**Server Fault Messages:** The server will detect certain fault conditions in the system and light Status LEDs to indicate the failure. The server will light these LEDs for faults whether alarm automation is on or off line.

When automation is on line and there is a fault, the server will write explanatory messages to the LCD display with additional information regarding the fault.

**When automation is off line,** the primary use of the bottom three lines of the LCD display will be to display alarm, restoral and status messages. If automation is off line and there are no such messages to display, the message “AUTOMATION OFF” will appear on the display. Note that this means that server fault conditions will only be reported by lighting an LED, and there will be no explanatory text for them on the LCD display when automation is off line.

The table to the right shows what message the server will display when status LEDs are lit. All messages in the table except the “Automation Off” will only be seen when automation is online. For additional explanation of the messages, refer to “Status Panel” and “Alert Panel” in the Front Panel section of the Technical Specification in section 3 of the User Manual.

LED	Message – Comment
RECEIVER	LPT – printer offline DSK – hard disk errors
CPU	None
ETHERNET	IPL – iplink heartbeat missing
AUTOMATION	AUTOMATION OFF
RF INTERFERENCE	RFI – radio interference
POWER	None

Shown to the right is an example of a message produced when Automation is online and a server fault condition exists.

When a failure message is received, the Alert LED will be turned on in addition to a status LED for the condition. This will also activate the alert sounder. The operator may press the SILENCE button to turn the buzzer off. The operator may press the ACKNOWLEDGE button to turn the Alert LED off.

The status LED will not be turned off and the failure message will not be cleared from the LCD screen until the operator corrects the failure. When the server detects the correction it will turn off the LED for that failure and remove the associated message from the LCD display.

#.## (C)2005-06 AES
LN1 7070 18 E140
GRP00 ZONE 0008
07/07/06 12:19

Example of an Alarm

#.## (C)2005-06 AES
AUTOMATION OFF

Automation Offline

#.## (C)2005-06 AES
LCD #.## LPT
IPL 7070
07/07/06 12:19

**Hard Disk Drive Failure / Watchdog Timer / Hung process detection:** The following is displayed if the Hard Disk Drive becomes unavailable. The CPU and Alert LED will be on and the Alert Sounder will be activated. This is an indication that a Hung Process has occurred which will occur for a number of failures including a Hard Disk Failure. Corrective action must be taken before the MultiNet Receiver can be put back into service. Contact AES Support for assistance

COMM FAILED
VERSION #.##

**LCD Communication Failure:** The message shown to the upper right will also be displayed if the LCD board loses its communication link with the main processor board. The MultiNet Receiver can remain operational with output to the printer and Alarm Automation functioning normally. The receiver should not be operated in this failure mode. The source of the failure must be repaired before continued operation of this receiver.

## **Appendix C**

### **Software installation Instructions**

AES configures the hard drive for use in a MultiNet Receiver. A duplicating process is used to create the hard drive formatting and software installation. Contact AES if you need to obtain a new hard drive for replacement or to reinstall the Linux or MultiNet Receiver programs.

Part Number: 40-7170

Title: AES 7170 IP-Link Transceiver (Remote & Local) – User manual

This Installation and Operation Manual provides instruction for installing and setting up the 7170 IP-Link Transceiver.

Part Number: 40-7705I-IS

Title: AES 7705i MultiNet Receiver System – Initial Installation and Setup Guide

This Installation and Setup Guide provides instruction for installing and setting up the MultiNet system including the 7705i / and the 7170 IP-Link Transceiver.

Part Number: 40-7705I-UM

Title: AES 7705i MultiNet receiver System – User manual

This document. Installation and operation guide for the MultiNet receiver.

## Appendix D

### Sharing the Serial Port with additional Business Units

An additional Business Unit that creates Alarm data to be sent to Automation using an already configured and assigned Serial Port must be linked to the Business Unit originally setup to use that specific serial port.

When creating an additional Business Unit, do not select the Alarm Automation System checkbox in the create Business Unit screen. After configuring the new Business Unit as described in section 7, follow the steps below to direct the alarm automation output of the newly created Business Unit to the original Business Unit that was originally assigned the Automation serial port.

Use the Modify Business Unit function to review the settings and verify that the Serial Device Name and Heartbeat Signal Frequency fields under the Serial Port Parameters section are blank. The Receiver Number can be set different or the same for each new Business Unit up to 15 numbers (1-9 and A-F) are available. 0 is not an available option. Alpha letters except A-F are not available choices.

**Note 1:** In the commands below, replace (*secondBU*) with the actual case sensitive name used to create the additional Business Unit without the parentheses.

**Note 2:** In the commands below replace (*firstBU*) with the actual case sensitive name used to create the first or original Business Unit without the parentheses.

1. Select or start a Konsole shell window.
2. Change to the directory that contains the configuration files.  
From the Konsole Shell, enter the following command:  
`cd /usr/local/aes/cfg<Enter>`
3. Type **ls<Enter>** to get a list of the configuration files in the directory. Confirm the case sensitive names of the files that are listed in the following steps.
4. The following steps are used to modify an existing or create the file for the new Business Unit with the information needed to direct Alarm Automation output to the Business Unit that was first created to control the Alarm Automation ports,
5. To append or create the new Business Unit's, file enter the following command:  
`cat >> ipctrl.(secondBU).cfg<Enter>`
6. To add the instruction for directing alarm output allowing the sharing of the serial port, carefully type the following, replacing (*firstBU*) with the case sensitive name used to create the first or original Business Unit:  
`deliverBU=(firstBU)<Enter>`
7. To close the file and exit the utility type the following character combination:  
<Ctrl> + C
8. At the command prompt of the Konsole terminal, enter the following command:  
`chmod 777 ipctrl.(secondBU).cfg<Enter>`

9. Confirm the existence of the needed files with the ls command:  
ls<Enter>  
There should be a file for each Business Unit. Each file begins with “ipctrl.” immediately followed by the case sensitive name of the Business Unit and ending with “.cfg”.
10. Next, using the cat command, view the contents of the each file and confirm that all files related to an existing Business unit have the same line as instructed to add in step 6 above.
11. Once the files are confirmed to exist and have the correct instruction, the MultiNet programs should be stopped and restarted to ensure the new settings are in effect. At the Konsole screen enter the following commands.  
stopall aesctrl<Enter> then  
startall aesctrl<Enter>
12. Create alarm signals using a Subscriber in the first or original Business Unit and confirm proper delivery to Alarm Automation.
13. Create alarm signals using a Subscriber in the additional Business Unit and confirm proper delivery to Alarm Automation.
14. If there are any other Business Units they should be tested as well.

## Appendix E

### Alarm Output Codes Produced by the MultiNet receiver

#### ***Alarm Output Overview:***

For many events that occur in the MultiNet system, alarm messages are created and communicated to an automation system. Communicators (Subscribers) in the MultiNet system and the MultiNet Receiver itself generate these events. This appendix is a list and description of those messages.

The MultiNet Receiver supports two different alarm output formats. The output formats available are the AES' Ademco 685 compatible format, and the AES' Radionics 6500 compatible format.

The communication parameters of the MultiNet Receiver can be configured to most available standards. The default parameters for AES Receivers has always been 1200 BPS, 7 data bits, Odd parity, 2 stop bits, Software ACK/NAK and will use DSR/DTR connection hardware handshaking. The communication parameters for Alarm Automation are programmed during the creation or editing of a Business Unit.

In Ademco 685-output format the signals received from a subscriber are translated into an appropriate Ademco 685 message. ***IntelliTap*** messages are passed through as received only changing the receiver number and line card as discussed in this section.

In Radionics 6500-output format the signals received from a subscriber are translated into an appropriate Radionics 6500 message. This format attempts to translate Ademco Contact ID (CID) codes passed through an ***IntelliTap***, to an appropriate Radionics 6500 message.

#### ***AES' Ademco 685 compatible output format:***

This mode will provide output using 3 line cards; line card 1 is for AES subscriber, IP-Link and receiver messages, line card 3 is for Contact ID messages received through ***IntelliTap***, and line card 4 is for 4+2 messages received through ***IntelliTap***.

Line Card # 1            AES signals from Subscribers and Receivers.  
*Signal format:*        <LF>RLsACCTs18sQEEEsGGsCNNNs<CR>

*Key to codes used in signal format above:*

<LF>        = Line feed code.  
R            = Receiver number, user programmable. Between 1 - 9 and A - F.  
              Receiver numbers are tied to and identify the Business Unit.  
L            = Line card number, Line card is selected by software. 1 - 4  
ACCT        = Four digit receiver or subscriber ID.  
18          = 18 for AES signals. As received for others. .18 means CID format follows.  
QEEE        = Event qualifier, will be an E for new Event, R for Restore of event or a  
              P for a Prior event still not restored to normal, during a Status or Check-In  
EEE         = Event code (See Event Codes below)  
GG          = 00 for AES signals. As received for IntelliTap. Group or partition  
C            = C for AES signals. As received for others. U = user.  
NNN        = Zone/contact ID, Status or Fault code  
s            = Single <Blank space>  
<CR>        = Carriage return code.

## Event Code Usage for Ademco 685 Output Emulation

<i>Event Code</i>	<i>Universal Description // AES specific Usage</i>
110	Fire // Subscriber Zone designated for Fire
130	Burglary // Subscriber Zone designated for Burglary
140	Alarm // Subscriber's Zone Input Off-Normal
145	Expansion module tamper // 7170 IP-Link Transceiver Enclosure Tamper (Zone/contact = 906)
200	Fire Supervisory // Subscriber Zone designated for Fire Supervisory
300	System Trouble // Subscriber Zone designated for Fire Trouble
300	System Trouble // MultiNet Receiver's LCD or LCD offline (for LCD Zone/contact = 902) (for LED Zone/contact = 903)
301	AC Loss // IP-Link AC input failure (Zone/contact = 912)
302	Low system battery // IP-Link low battery condition (Zone/contact = 911)
305	System reset // Watchdog, Pushbutton or Power-On Reset (Watchdog or pushbutton Zone/contact = 901) (Power-on Zone/contact = 902)
307	Self Test Failure // Diagnostic Fault (Zone/contact = Fault Code) (Zone 800 = restoral of all Prior faults) (See below for codes 801-809)
309	Battery test failure // Charger Voltage low (Zone/contact = 910)
336	Local printer failure // Printer off-line (Zone/contact = 904)
350	Communications trouble // RF Interference (Zone/contact = 906)
351	Telco 1 Fault / IntelliTap detected phone line cut (Zone/contact = 905)
353	Long range radio xmitter fault // Multiple IP-Links with same Unit ID (Zone/contact = 906)
354	Failure to communicate event // Exception – Unit failed to Check-In (Zone/contact = 906) Generated by Receiver on failure to receive test message within specified time frame
354	Failure to communicate event // Exception – TCP/IP Supervision Failure (Zone/contact = 906)
354	Failure to communicate event // Exception – MultiNet Modem Failure (Zone/contact = 907)
354	Failure to communicate event // Exception – IP-Link Modem Failure (Zone/contact = 908)
354	Failure to communicate event // Exception – Unit NetCon is 6 or 7 (Zone/contact = 915)
355	Loss of Radio Supervision // IP-Link RF Ping Failure (Zone/contact = 906)
356	Loss of central polling // Acknowledge Delay or Communication timeout (Zone/contact = 903)
357	Antenna Supervision Module // IP-Link antenna cut/restoral (Zone/contact = 916)
370	Protection Loop // Zone Trouble. (Zone/contact ID = 001 to 008)
370	Protection Loop // 7744 Battery Charger Trouble (Zone/contact ID = 009)
370	Protection Loop // 7744 Ground Fault (Zone/contact ID = 010)
602	Periodic test report // Automatic Supervisory Check-In

<i>Example Message Strings</i>	<i>Description of Event Produced by an AES Subscribers</i>
R1 ACCT 18 E602 00 C000	Automatic Supervisory Check-In. Zone/contact ID = 000
R1 ACCT 18 E140 00 C0nn	Alarm Signal or input went active. Zone/contact ID = Zone Number
R1 ACCT 18 P140 00 C0nn	Prior Alarm. Input still active. Zone/contact ID = Zone Number Reported during Status or Automatic Supervisory Check-In
R1 ACCT 18 R140 00 C0nn	Alarm Restoral or input to normal. Zone/contact ID = Zone Number
R1 ACCT 18 E305 00 C901	Watchdog, or Push-button Reset. Zone/contact ID = 901
R1 ACCT 18 E305 00 C902	Power-On Reset. Zone/contact ID = 902
R1 ACCT 18 E307 00 C8nn	Diagnostic Fault. Zone/contact ID = Fault Code. See Fault code list on a following page.
R1 ACCT 18 R307 00 C800	No Faults, Unit OK or Restoral of all Prior Faults. Zone/contact ID = 800
R1 ACCT 18 P307 00 C8nn	Prior Diagnostic Fault still active. Reported during Check-In. Zone/contact ID = Fault Code. See Fault code list on a following page.
R1 ACCT 18 E351 00 C905	IntelliTap phone line cut. Zone/contact ID = 905
R1 ACCT 18 R351 00 C905	Restoral of IntelliTap phone line cut. Zone/contact ID = 905
R1 ACCT 18 E354 00 C906	Exception – Unit or Subscriber Failed to Check-In. Zone/contact ID = 906 Generated by MultiNet Receiver on failure to receive test message within specified time frame.
R1 ACCT 18 E354 00 C915	Exception – Unit or Subscriber NetCon is 6 or 7. Zone/contact ID = 915 Generated by MultiNet Receiver on failure to receive test message within specified time frame.
R1 ACCT 18 R354 00 C906	Exception Restoral – Unit or Subscriber on Line. Zone/contact ID = 906
R1 ACCT 18 R354 00 C915	Exception Restoral – Unit or Subscriber NetCon is 5 or lower. Zone/contact ID = 915
R1 ACCT 18 E356 00 C903	Acknowledge Delay or Communication time-out. Zone/contact ID = 903
R1 ACCT 18 E370 00 C0nn	Zone Trouble. Zone/contact ID = Zone Number
R1 ACCT 18 P370 00 C0nn	Zone Trouble still active. Zone/contact ID = Zone Number Reported during Status Request or Automatic Supervisory Check-In
R1 ACCT 18 R370 00 C0nn	Zone Trouble Restoral. Zone/contact ID = Zone Number Note that this is a restore signal and may not cause an alert. Look in log files.

REC# = MultiNet Receiver ID	IPL# = IP-Link ID	ACCT = Subscriber ID
n or nn = variable number, rang as specified		

*Example Message Strings*

*Description of Event Produced by a MultiNet Receiver or IP-Link Transceiver*

---

R1 IPL# 18 E145 00 C906	7170, IP-Link Transceiver Enclosure Tamper ID = 906
R1 IPL# 18 R145 00 C906	7170, IP-Link Transceiver Enclosure Tamper Restore ID = 906
R1 REC# 18 E300 00 C902	LCD offline. Zone/contact ID = 902
R1 REC# 18 E300 00 C903	Loss of LED. Zone/contact ID = 903
R1 IPL# 18 E301 00 C912	AC Failure at IP-Link. Zone/contact ID = 912
R1 IPL# 18 E302 00 C911	Battery Trouble at IP-Link. Zone/contact ID = 911
R1 IPL# 18 E307 00 C80n	Diagnostic Fault. Zone/contact ID = Fault Code. See Fault code list on a following page.
R1 REC# 18 E307 00 C907	Exception – Modem Interface Test Failed at Server. Zone/contact ID = 907
R1 IPL# 18 E309 00 C910	Charger Trouble at IP-Link. Zone/contact ID = 910
R1 REC# 18 R309 00 C910	Charger Trouble Restore at IP-Link. Zone/contact ID = 910
R1 REC# 18 E336 00 C904	Printer off-line. Zone/contact ID = 904
R1 REC# 18 E350 00 C906	RF Interference. Zone/contact ID = 906
R1 REC# 18 E353 00 C906	Multiple IP-Links detected with same ID. Zone/contact ID = 906
R1 IPL# 18 E354 00 C905	Exception – Phone Line/Modem Fail at IP-Link. Zone/contact ID = 905
R1 REC# 18 E354 00 C906	Exception – IP-Link Supervision Failure. Zone/contact ID = 906
R1 REC# 18 E354 00 C907	IP-Link RF Offline. Zone/contact ID = 907
R1 REC# 18 E354 00 C907	MultiNet Local Modem failure. Zone/contact ID = 907
R1 REC# 18 E354 00 C908	IP-Link Modem failure. Zone/contact ID = 908
R1 REC# 18 E356 00 C906	IP-Link Ping Failure. Zone/contact ID = 906
R1 REC# 18 E357 00 C916	IP-Link antenna cut detected. Zone/contact ID = 916
R1 REC# 18 R357 00 C916	IP-Link antenna restored. Zone/contact ID = 916

REC# = MultiNet Receiver ID	IPL# = IP-Link ID	ACCT = Subscriber ID
n or nn = variable number, rang as specified		



*Fault and Status Codes (Zone information): AES Subscribers and MultiNet Receiver (not all are used by each device):*

- 800 = No Faults, Unit OK or Restoral of all Prior Faults.
  - 801 = Low Battery - Voltage less than 11.0V
  - 802 = RAM Data error or RAM corrupted - Zone activation will not be reported (Sub. V1.71 &+). Reprogram Unit
  - 803 = 7050 and 7000/2 - U11 RAM Chip Internal Battery Bad  
7050E - EEPROM corrupted, or not present
  - 804 = 7050E - A to D Converter Faulted - Zone activation will not be reported (Sub. V1.71 &+).
  - 804 = External Device failed
  - 805 = Modem Chip Failed or missing - U9 in 7050 and 7000/2
  - 806 = Timing Error between CPU and Modem
  - 807 = Ram Chip Read/Write test Failure - U11 in 7050 and 7000/2
  - 808 = Modem Loop back Failed - U9 in 7050 and 7000/2
  - 809 = 7050E - AC Fail or DC voltage supplied by AC has dropped below 12V
- 

Line Card # 3            Contact ID received through **IntelliTap**.

Signal format:        <LF>RLsACCTs18sEEEEsGGsNNNNs<CR>

See “Line card #1”, “Signal format” in “Ademco 685 compatible output” for Key to codes used in signal format for Line Card #3 above.

This Information is passed through. Receiver number is set as programmed in the MultiNet setup. Line card is set to 3.

Line Card # 4            4+2 received through **IntelliTap**.

Signal format:        <LF>RLsACCTsCC<CR>

CC        = two digit zone code.

See “Line card #1”, “Signal format” in “Ademco 685 compatible output” for Key to codes used in signal format for Line Card #4 above.

This Information is passed through. Receiver number is set as programmed in the MultiNet setup. Line card is set to 4.

Input Signals:

In Ademco mode the receiver will respond to 3 inputs or signals from the monitoring system.

S            receiver reply will be - <LF>00sOKAYs@<CR>

<0x06> or ASCII code 6        receiver considers last message acknowledged

<0x15> or ASCII code 21        receiver will re-send last message (if not acknowledged)

***Radionics 6500 compatible output format:***

This mode will provide the output of 3 line cards; line card 1 is for AES subscriber and receiver signals, line card 3 is for Contact ID signals from ***IntelliTap***, and line card 4 is for 4+2 signals from ***IntelliTap***.

Contact ID signals are translated into an AES' Radionics message as outlined under line card # 3 and 4 elsewhere in this appendix. Due to this translation it is preferred that the Ademco emulation be used when ***IntelliTap*** or other contact ID message producing interfaces are used.

Line Card # 1            AES signals from subscribers and receivers.

*Signal format:*            1RRLsssssACCTEEsNNNs<0x14>

*Key to codes used in signal format above:*

- 1            = 1 is for automation signal. (a 3 indicates text data)
- RR            = Receiver number, user programmable. Between 01 and FF.
- L            = Line card number, Line card is selected by firmware or software. 1 - 4
- ACCT        = Four digit subscriber ID or 4 blank spaces for AES receiver
- EE            = Event code (See event codes below)
- NNN        = Zone, status or fault code \*
- s            = <Blank space>
- <0x14>      = Termination character

\* Note: The value of NNN or (N2N1N0) in Radionics 6500 format, (or N2 N1 N0 as used for this example) is computed as follows: Value = N2 X 16 + (N1 X 10 + N0). The numbers in positions N1 and N0 represent the two digit decimal equivalent of a single digit hexadecimal number. It will never be greater than decimal 15. The number in position N2 represent the decimal equivalent of a Hexadecimal number where 1 = decimal 16 and 2 = decimal 32.

*Event plus Zone, Status and Fault Codes, Produced for Events Created by Subscribers:*

A 000	Automatic Supervisory Check-In	10R1	ACCT A 000
A NNN	Alarm Signal Zone NNN *	10R1	ACCT A nnn
SA NNN	Prior Alarm zone NNN * Input still active. Reported during Status Request or Check-In	10R1	ACCTSA nnn
R NNN	Alarm or Zone trouble Restoral or input to normal - Zone NNN *	10R1	ACCT R nnn
Y 800	Diagnostic Fault - "No Faults, Unit OK or Restoral of all Prior Faults" see Diagnostic Faults below	10R1	ACCT Y 800
Y 801	Diagnostic Fault - "Low Battery" - Voltage less than 11.0V	10R1	ACCT Y 801
Y 802	Diagnostic Fault - "RAM Data error or RAM corrupted" - Zone activation will not be reported (Sub. V1.71+). Reprogram Unit	10R1	ACCT Y 802
Y 803	Diagnostic Fault - "7050 - U11 RAM Chip Internal Battery Bad" "7050E - EEPROM corrupted, or not present"	10R1	ACCT Y 803
Y 804	Diagnostic Fault - "7050E - A to D Converter Faulted" - Zone activation will not be reported (Sub. V1.71+).	10R1	ACCT Y 804
Y 805	Diagnostic Fault - "Modem Chip Failed or missing" - 7050 U9	10R1	ACCT Y 805
Y 806	Diagnostic Fault - "Timing Error between CPU and Modem"	10R1	ACCT Y 806
Y 807	Diagnostic Fault - "Ram Chip Read/Write test Failure" - 7050 U11	10R1	ACCT Y 807
Y 808	Diagnostic Fault - "Modem Loop back Failed" -7050 U9"	10R1	ACCT Y 808
Y 809	Diagnostic Fault - "7050E - AC Fail" or "DC voltage supplied by AC has dropped below 12V"	10R1	ACCT Y 809
SY 80n	Prior Diagnostic Fault still active. Reported during Check-In. (n = 1-9, see Diagnostic Faults above)	10R1	ACCT Y 80n
T 901	Trouble - "Watchdog or Push-button Reset"	10R1	ACCT T 901
T 902	Trouble - "Power-On Reset"	10R1	ACCT T 902
R 903	Trouble - "Communication time-out or Acknowledge Delay"	10R1	ACCT T 903
T 904	Trouble -	10R1	ACCT T 904
T 905	Trouble - "IntelliTap phone line cut."	10R1	ACCT T 905
R 905	Trouble Restore- "IntelliTap phone line restore."	10R1	ACCT T 905
T 906	Exception - "Unit or Subscriber Failed to Check-In" Generated by MultiNet Receiver on failure to receive test message within specified time frame.	10R1	ACCT T 906
R 906	Exception Restoral - "Unit or Subscriber on Line" or "... has now checked-in"	10R1	ACCT R 906
T NNN	Zone Trouble Signal. Zone NNN *	10R1	ACCT T nnn
ST NNN	Prior Zone Trouble zone NNN * Input still active. Reported during Status Request or Check-In	10R1	ACCTST nnn

*Event plus Status and Fault codes, AES MultiNet Receiver:*

Y 802	Diagnostic Fault - "RAM Data error or RAM corrupted"	10R1	IPL# Y 802
Y 803	Diagnostic Fault - "U11 RAM Chip missing or Internal Battery Bad"	10R1	IPL# Y 803
Y 804	Diagnostic Fault - "Reserved"	10R1	ACCT Y 804
Y 805	Diagnostic Fault - "U9 Modem Chip Failed or missing"	10R1	IPL# Y 805
Y 806	Diagnostic Fault - "Timing Error between CPU and Modem"	10R1	IPL# Y 806
Y 807	Diagnostic Fault - "U11 Ram Chip Read/Write test Failure"	10R1	IPL# Y 807
Y 808	Diagnostic Fault - "Modem Loop back Failed"	10R1	IPL# Y 808
X 11	"Low Battery"	10R1	REC# X 11
X 12	"Low Battery Restore"	10R1	REC# X 12
X 26	"Unknown message revision, invalid report."	10R1	IPL# X 26
X 812	"Multiple active Central Controllers detected"	10R1	REC# X 812
X 13	"AC Fault"	10R1	REC# X 13
X 14	"AC Restore"	10R1	REC# X 14
X 20	"Event Printer offline"	10R1	REC# X 20
X 19	"Event Printer restore, offline"	10R1	REC# X 19
X 813	"7030, Transceiver Enclosure Tamper"	10R1	IPL# X 813
X 913	"7030, Transceiver Enclosure Tamper Restore"	10R1	IPL# X 913
X 814	"7030, Transceiver Enclosure Voltage Fault"	10R1	IPL# X 814
X 815	"7030, Transceiver Enclosure Voltage Restore"	10R1	IPL# X 815
X 911	"LCD offline"	10R1	REC# X 911
X 912	"LCD online/restore"	10R1	REC# X 912

# 2 Line Card SIC used in Optex Morse Genesys 824 Alpha  
Signal format: 1RRLsssssACCTEEsNNNs<0x14>  
Line card 2 and SIC Not Supported by MultiNet system

Line Card # 3 Contact ID received from **IntelliTap**. Events are translated.  
Signal format: 1RRLsssssACCTEEsNNNs<0x14>

See “Line card #1”, “Signal format” in “Radionics 6500 compatible output” for Key to codes used in signal format for Line Card #3 above.

**The received Contact ID formatted message is translated to a Radionics compatible format as described below. Receiver number is set as programmed in Business Unit of MultiNet receiver. Line card is set to 3.**

*Event plus Zone, Status and Fault Codes, AES Subscribers with IntelliTap.*

Event Codes with numbers E1XX and E2XX will be reported as: see exception ♣

A NNN where NNN is the Point ID or Contact ID number

♣ Event Codes with numbers E12X will be reported as:

D (D followed by 4 spaces.)

This is an exception to E1XX above ♣

Event Codes with numbers P1XX and P2XX will be reported as:

SA NNN where NNN is the Point ID or Contact ID number

Contact ID Event Codes with numbers R121 and contact 000 will be reported as:

A NNN where NNN is the Point ID or Contact ID number

Event Code E121 C000 will be reported as:

D 000

Event Codes E3XX, and R3XX with non-zero zone data will be reported as:

T NNN where NNN is the Point ID or Contact ID number

Event Codes with numbers P3XX with non-zero zone data will be reported as:

ST NNN where NNN is the Point ID or Contact ID number

Event Codes E3XX and R3XX with Point ID or Contact ID value of 000 are reported as:

Y 3XX where 3XX is a copy of the event code

Event Codes P3XX with Point ID or Contact ID value of 000 will be reported as:

SY 3XX where 3XX is a copy of the event code

Event Codes with numbers E4XX will be reported as:

O NNN where NNN is the Point ID or Contact ID number

Event Codes with numbers R4XX will be reported as:

C NNN where NNN is the Point ID or Contact ID number

All other Contact ID Event Codes will be reported as:

Y XXX where XXX is a copy of the event code. OR

SY XXX when PXXX is the event and where XXX is the Point ID or Contact ID number

**Note: AES recommends not using Radionics 6500 emulation, when using *IntelliTap* to report Contact ID. If at all possible use Ademco 685 emulation if you have a monitoring system that can support it.**

( Line card #4 next page)

Line Card # 4 4+2 received from *IntelliTap*. Events are translated.

Signal format: 1RRLsssssACCTsAssCC<0x14>

A = Character A for alarm event.

CC = two digit zone code.

See “Line card #1”, “Signal format” in “Mode 1 – Radionics 6500 compatible output” for explanation of other signal format codes.

*Event plus Zone, Status and Fault Codes, AES Subscribers with IntelliTap.*

All 4+2 messages will be reported as follows:

AssCC where CC is a direct copy of the received 4+2 report code.

Input Signals:

In mode 1 the AES receiver will respond to two inputs or signals from the monitoring system.

<0x06> receiver considers last message acknowledged

<0x15> receiver will re-send last message (if not acknowledged)

Other Messages:

301ssAESs7000sVX.XXs<0x14>

X.XX this reports the version number of the firmware

## **Appendix F**

### **Printer Messages Produced by the MultiNet receiver**

For many events that occur in the MultiNet system, messages are created and printed on the attached printer. These events are created by the communicators (Subscribers) in the MultiNet system, IP-Link Transceivers and by the MultiNet Receiver itself. There are also a number of reports that can be printed. Following is a list and description of some of those messages.

Controls for what is printed are located within the Business Unit configurations and throughout the MultiNet menu system.

#### **Print format for Events such as alarm and fault messages:**

When an event is reported to the MultiNet receiver and the receiver determines that it needs to be printed the following general format is used.

#### **Day Mmm dd hh:mm:ss YYYY - - Message...**

The printed line begins with date and time stamp indicating when the MultiNet Receiver received the message.

Day	3 letter abbreviation for day of week
Mmm	3 letter abbreviation for month of year
dd	Date of month
hh:mm	Hour of day and minute of the hour
ss	Second of the minute
YYYY	Four digit Year

Following the Date stamp is a three-letter code identifying the device or origin of the reported message. Following is a list of those codes:

IPL	IP-Link message
LPT	Printer fault
MDM	Modem
RFI	Radio Frequency Interference message
OFF	Offline message
--	System Message

Message...= This portion varies depending on the type of event or message that is being printed. Examples Follow:

-- IPLink 0000#####, Power On Reset

-- E140 ACCT 9371 ZONE C006  
11 9371 18 A140 00 C006  
(Tracking=21924)

-- IPLink 00002222, Starting Modem Test!

Manual Acknowledge (Tracking=21924) -> 11 9371 18 A140 00 C006

-- Alarm Automation System is up! (serial)

-- IPL 1111 Battery Voltage - Fault

#### **Alarm codes printed are defined in Appendix E**