

Fast and Accurate Insulation Diagnostics and Moisture Assessment



The IDAX product line has accurately assessed moisture levels in oil-paper insulation for more than a decade. Now Pax Diagnostics introduces a smaller, lighter and faster version; the IDAX-300.

IDAX-300 provides an accurate and reliable condition assessment of insulations in transformers, bushings, generators and cables. The IDAX-300 system maximizes the outcome of maintenance activities allowing for load and service life optimization.

IDAX-300 is smaller, lighter and faster than its predecessor IDAX-206. It maintains the same accuracy and ability to provide reliable data using true DFR (Dielectric Frequency Response), also known as FDS (Frequency Domain Spectroscopy), without compromises. The new software makes testing both easier and faster, allowing transformer moisture assessment in less than 18 minutes.

IDAX-300 measures the Capacitance and Tan Delta / Power Factor of the insulation between power transformer windings at multiple frequencies. Plotting the results as a curve makes it possible to assess the condition of the oil and solid insulation, assess the moisture level in the solid insulation and other potential insulation problems. The test can be performed at any temperature.

Application

A closer look at the IDAX solution

With an aging power transformer population, today's electrical utility industry faces a tough challenge as transformer failures and consequent repair and revenue loss costs millions of dollars. Transformers have become one of the most mission critical components in the electrical grid.

The need for reliable monitoring and diagnostic methods drives the world's leading experts to evaluate new technologies that improve reliability and optimize the use of every grid component [1].

IDAX is a revolutionary insulation diagnostic instrument based on DFR (dielectric frequency response), also known as FDS (frequency domain spectroscopy). This analysis technique has been used in laboratories for decades but IDAX is the first instrument designed for field use. The IDAX instrument and measurement principle has been used and verified around the world over the last ten years.

Application

One of the most important applications for IDAX is to determine the moisture content in transformer insulation. Moisture in the insulation significantly accelerates the aging process. Moisture can cause bubbles between windings with catastrophic failures as result. IDAX provides reliable moisture assessments in one test. The test can be made at any temperature and takes less than 18 minutes.

Water in oil vs. paper

Assessing reliable moisture content in transformer insulation based on oil sample tests is unreliable as the water migrates between the solid insulation and oil as temperature changes. An oil sample has to be taken at relatively high temperature and when the transformer is in equilibrium. Unfortunately, this is a rare state for transformers thus resulting in unreliable assessments.

Figure 1 shows how the significant and potentially critical difference of 0.5% respectively 3.0% moisture in paper, correlates to the insignificant difference of 1 respectively 4 Parts Per Million (PPM) in an oil sample obtained at 20 °C (68 °F) [2].

The test

Dielectric loss or power factor is frequency and temperature dependent, so by injecting test signals at discrete frequency steps between 1 kHz and 1 mHz while recording results at each point, a curve is created (Fig 2).

This profile represent the properties of the insulation material in the transformer and will be used in further analysis as described below. The oil temperature is recorded for reliable evaluations.

The model

The insulation between the windings in a transformer consists of barriers, spacers and an oil duct for cooling purposes (Fig 3). The model formula varies all insulation parameters to simulate every possible geometrical design and applies Arrhenius formula to compensate for temperature dependence in the material [3]. The IDAX software creates new model curves and compares them to the measured curve until the best possible match is reached. The final results are presented as % of moisture in paper and a separate value for oil conductivity (Fig 4 and 5).

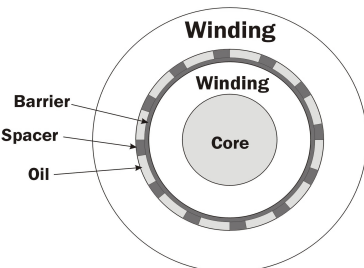

Fig 3. typical insulation design

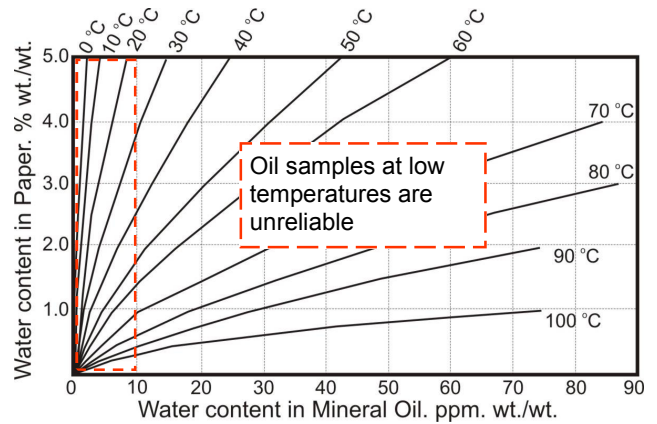

Fig 1. Water in oil vs. paper correlation is unreliable at low temp

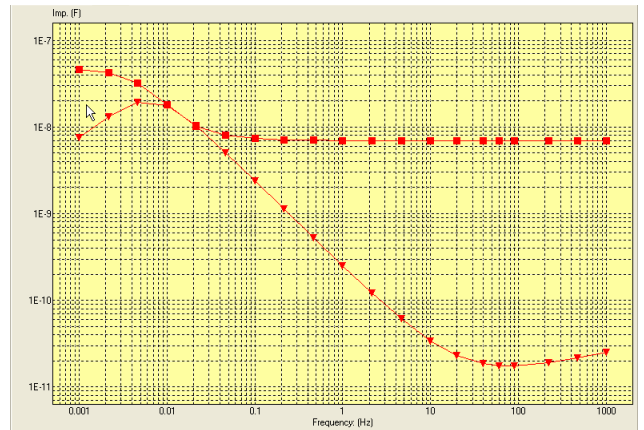

Fig 2. Power factor curve presented as capacitance and loss

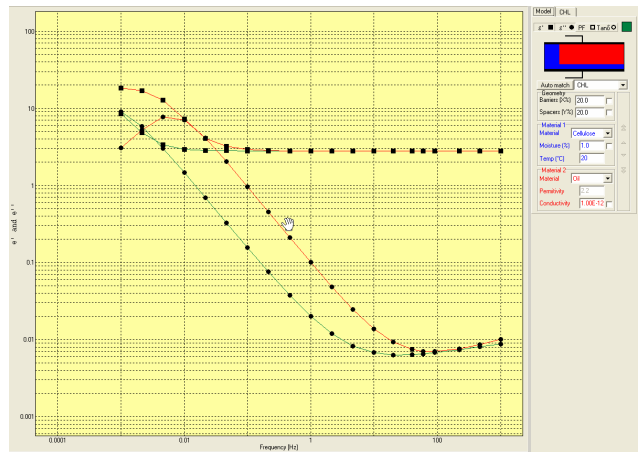

Fig 4. Before matching. Green-Model, Red-Measurement

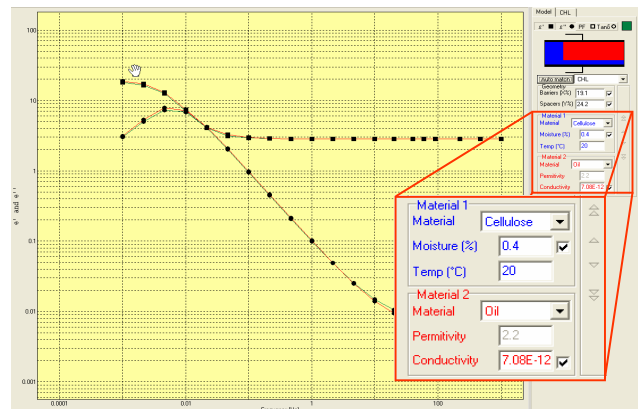

Fig 5. After matching. Result: 0.4 % at 20 deg C

What controls the curve?

The general rule is that moisture is visible in the highest and in lowest frequencies. Oil conductivity is dominant in the medium frequency and the temperature shifts the curve to the right and to the left respectively (Fig 6).

One point is not enough

This leads to another advantage of the IDAX method. Traditional Tan Delta / Power Factor testing presents only one value at mains frequency.

Figure 7 show that a single power factor value cannot provide conclusive information about the potential problem.

In this example, two transformers have the same Power Factor value at 60Hz. However, one of them is wet (3.6%) and should be considered for a dry-out while the oil in the other unit should be replaced or refurbished.

Conclusion

IDAX is a well-proven system for determining moisture content in transformer insulation. The instrument and method including the modeling software has been tested and verified with numerous customers.

References:

- [1] S.M. Gubanski, J. Blennow, L. Karlsson, K. Feser, S. Tenbolen, C. Neumann, H. Moscicka-Grzesiak, A. Filipowski, L. Tatarski "Reliable Diagnostics of HV Transformer Insulation for Safety Assurance of Power Transmission System" Cigre Paris Aug 2006
- [2] From. P.J.Griffin, C. M. Bruce and J. D. Christie: "Comparison of Water Equilibrium in Silicone and Mineral Oil Transformers", Minutes of the Fifty-Fifty Annual Conference of Doble Clients, Sec. 10-9.1, 1988
- [3] U. Gäfvert, L. Adeen, M. Tapper, P. Ghasemi, B. Jönsson, "Dielectric Spectroscopy in Time and Frequency Domain Applied to Diagnostics of Power Transformers", Proc. Of the 6th ICPADM, Xi'an, China, 2000

Test procedure

The test preparation and procedure is similar to a standard Tan Delta / Power Factor test, which means that the transformer has to be off-line and preferably disconnected from all connection hardware.

The IDAX Software guides the user through a test template where all connections are illustrated as per figure 8. Color markings on clamps (fig 9) makes it easy to connect according to the built in instructions. The test can be started as soon as the test cables are connected. Error messages on the screen inform the user if there are any errors in the connections.

The IDAX software operates on Windows XP and Vista and support standard USB, LAN and Bluetooth communication solutions.

IDAX-300 in the standard version is equipped with a three input measuring circuit allowing measurement of all test modes without time consuming change of cable connections. As an option, the IDAX-300 can be equipped with an a second measuring circuit that allows two independent measurements to be performed simultaneously, thus minimizing test time.

The optional Calibration Set enables simple and reliable calibration of the IDAX system. It also reduces instrument downtime and transport cost as the calibration box is the only part that needs to be sent in for calibration. The new design allows calibration in any local or national certified calibration facility, thus avoiding long delivery times and transport costs.

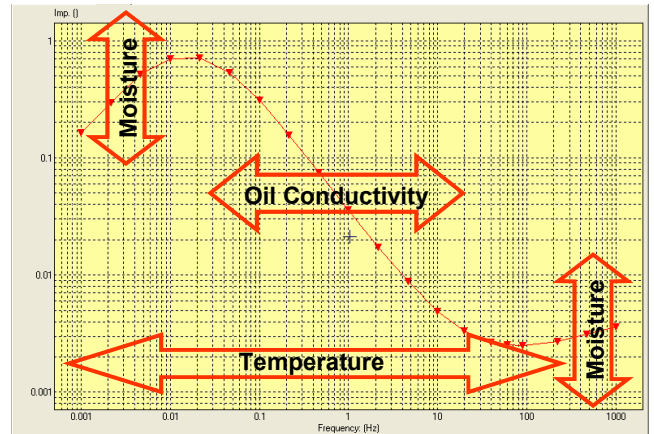

Fig 6. Oil conductivity and moisture influence

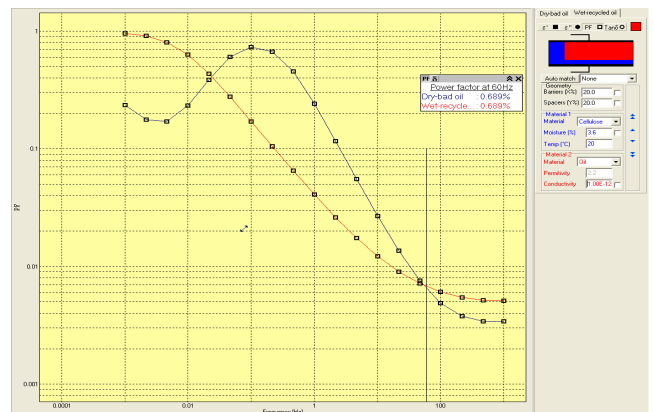

Fig 7. Blue: Dry with bad oil. Red: Wet with good oil

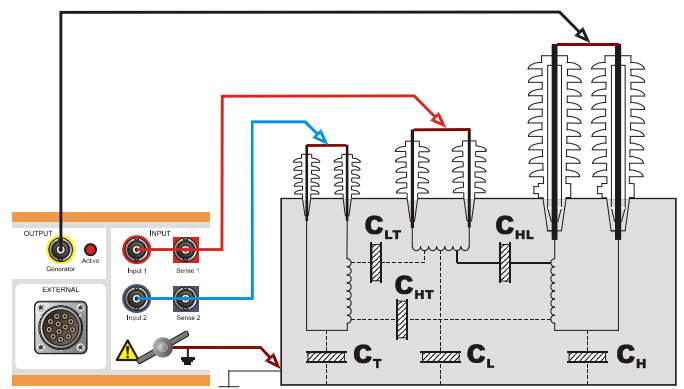

Fig 8. Example: connections to a three winding transformer

Order Information

IDAX-300 with accessories AG-190-90
Includes: IDAX-300 instrument, cable set 9 m / 30 ft, ground cable, hard transport case, soft case for accessories, software CD and User's Manual

Optional Accessories

Calibration Set	AG-900-10
Two channel measurement option	AG-902-00
Generator cable 18 m / 60 ft	GC-003-12
Measuring cable 18 m / 60 ft, red	GC-003-22
Measuring cable 18 m / 60 ft, blue	GC-003-32

Specification

Output

Voltage / current ranges, 10 V	0 – 10 V _{peak} / 0 – 50 mA peak
Voltage / current ranges, 200 V	0 – 200 V _{peak} / 0 – 50 mA peak
Frequency range	0.1 mHz – 7 kHz

Measurement

Inputs	Channel 1, Channel 2, Ground
Capacitance range	10 pF – 100 μF
Dissipation factor range	0 – 10 (with retained accuracy of capacitance – otherwise higher)
Accuracy	0.5 % + 1 pF > 1 % + 0.0003, 1 mHz – 100 Hz, C > 1 nF > 2 % + 0.0005, 0.1 mHz – 7 kHz, C > 1 nF
Noise level	Max 500 μA at 50 Hz / 60 Hz
Test modes	UST-1, UST-2, UST-1+2, GST-Guard 1, GST, Guard 2, GST-Guard 1+2, GST
Calibration	Calibration box allows field calibration, recommended interval 2 years.



General

Mains input (nominal)	90—265 V AC, 50 / 60 Hz
Power consumption (max)	250 VA
Dimensions, instrument	335 x 300 x 99 mm (17.7" x 6.3" x 16.1")
Dimensions, transport case	520 x 430 x 220 mm (22.7" x 9.4" x 21.3")
Weight instrument	4.9 kg (11 lbs)
Weight instrument + case	9.9 kg (22 lbs)
Weight accessories	8.5 kg (18 lbs) soft bag



IDAX-300 cable set

PC requirements

Operating system	Windows 2000, XP, Vista
CPU / RAM	Pentium 500 MHz / 512 Mb or better
Interface	USB 2.0

Environmental

Temperature, operating	0°C to +50°C (-4° F to +122° F)
Temperature, storage and transport	-40°C to +70°C (-40° F to +158° F)
Humidity	20% - 95% RH (non-condensing)
CE standards	IEC61010 (LVD) EN61326 (EMC)

Specifications subject to change without notice.



Pax Diagnostics AB
 Enhagslingen 6
 187 40 - Taby - Sweden
 Phone + 46 8 5250 3600
 Fax + 46 8 792 02 70
 Email: info@paxdiagnostics.com

ZB-AG1-01 A03E

pax
 DIAGNOSTICS