



USER MANUAL

SLIT LAMP MICROSCOPE

Model: GR-7



Version: 1.0

Gilras LLC

Thank you for purchasing our slit lamp microscope. The following is the description and specification of our product.

General description

- ☞ This user manual elaborates on the relevant technical specification and operation of the product.
- ☞ The classification of this instrument according to IEC 60601-1-2005 is specified in this manual.
- ☞ Labels and marks required by IEC 60601-1-2005 standard is stuck on the instruments and described in this user manual.
- ☞ Working principle: A beam of light attached to the slit lamp projects to the patients' eye, which forms an optical section of the living tissue of the eye, in this way the doctor can finish the observation and examination.
- ☞ Slit Lamp Microscopes are used to observe the disease of the anterior structures and tissue damage of eyes.

Instruments classification:

- ☞ This instrument is categorized to Class I Type B according to IEC 60601-1-2005 standard, which can not be used under two circumstances: a flammable anesthetic gas and air mixture, oxygen or nitrous oxide gas and air mixture. This instrument can be running continuously. It doesn't belong to category AP or APG.

The specification of this slit lamp microscope.

Microscope:

Type:	Galilean-Type
Magnification change:	Three steps revolving Drum
Eyepieces:	12.5X
Angle between eyepieces:	13°
Total magnification Ratio:	10X, 16X, 25X
Pupillary adjustment:	52mm~78mm
Diopter adjustment:	±6D
Field of view:	25X (Ø8.5mm), 16X (Ø13.5mm), 10X (Ø22mm)

Slit Illumination:

Slit width:	Continuously variable from 0 to 14mm (at 14mm, slit becomes a circle)
Slit length:	Continuously variable from 1mm to 14mm
Aperture diameters:	Ø14mm, Ø8mm, Ø3.5mm, Ø0.5mm
Slit angle:	0°-180°
Filters:	Heat-absorbing filter, Red-free filter, Cobalt Blue filter
Lamp:	6V/20W Halogen Lamp
Luminance:	≥50klx

Base:

Longitudinal movement:	90mm
Lateral movement:	100mm
Fine Base movement:	15mm
Vertical movement:	30mm

Chin-Rest:

Vertical movement:	80mm
Fixation Target	LED

Power:

Input voltage:	220V/110V $\sim\pm 10\%$
Input frequency:	50Hz/60Hz
Power Consumption:	30VA (max)

Output voltage:

Light:	6V (continuously adjustable)
Fixation:	3V

Dimension & Weight:

Dimension	740mm × 450mm x 550mm
Gross weight:	22Kg
Net weight:	16Kg

Working environment:

Temperature:	+5°C ~ +40°C
Relative humidity:	≤80%
Air pressure:	800hpa ~ 1060hpa

Storing environment:

Temperature:	-40°C ~ +55°C
Relative humidity:	≤93%
Air pressure:	700hpa ~ 1060hpa

Transporting environment:

Temperature:	-40°C ~ +55°C
Relative humidity:	≤93%
Air pressure:	700hpa ~ 1060hpa



General Requirements for Safety





Please read carefully about following precautions to avoid unexpected personal injury as well as the product being damaged and other possible dangers.

Precautions

1. In case there is any trouble, please first refer to the trouble-shooting guide. If it still can't work, please contact with the authorized distributor or our Repair Department.
2. Do not use this instrument in the environment prone to fire and blast or where there is much dust and with high temperature. Use it in room and simultaneously be careful to keep it clean and dry.
3. Check that all the wires are correctly and firmly connected before using. Ensure that the instrument is well grounded.
4. Please pay attention to all the ratings of the electrical connecting terminal.
5. Turn off the main power first before replacing the main bulb, flash lamp and fuse.
6. When replacing the power cable, please use the power cable in accordance with the notes in the instruction manual.
7. Don't touch the surface of the lens and prism with hand or hard objects.
8. Please be careful when using the moving parts of the slit lamp, in case that the movement of the base or microscope arm hurts people.
9. To prevent the instrument from falling down to floor, it should be placed on the floor where the inclination angle is less than 10°.
10. Please deal with the waste disposal produced by the machine following relevant laws and regulations.
11. Read carefully the safety and other signals on this machine in order to use the product safely.

The safety marks, icons and warning symbols stuck on this instrument.

Table one:

No.	mark	Description
1		TYPE B
2		Manufacturing date
3	Class I	The slit lamp is type I medical using equipment
4	Type B	English form of B type
5		WEEE mark Please deal with the waste disposal produced by the machine following relevant laws and regulations.
6		CE mark
7	PN:	Part Number
8	SN:	Serial Number
9		Power ON
10	○	Power OFF
11	Output	At the back of power supply box ,indicate outlet of the power
12	Input	At the back of power supply box ,indicate input of the power
13	Fuse F1A1250V	Rated value and current value
14	Power	At the front of power supply box, switch the power on and off
15	Voltage selector	Switch the input voltage from 110V to 220V
16	luminance 	The mark of light dimmer

EMC precautions:

Other medical instruments and equipment which needs to be installed on the same site using with this instrument shall comply with the same electromagnetic compatibility principle. The equipment which is unable to comply with the electromagnetic compatibility or is known with poor electromagnetic compatibility shall be installed 3 meters at least away from this equipment and powered by different power supply.



WEEE precautions:

Please dispose the waste electrical and electronic equipment in accordance with relevant regulations and laws.

Technical specifications

The slit lamp microscope is powered by network power supply. The following marks are required permanently affixed to the instruments according to IEC 60601-1-2005 Standard. The following table lists the tips for your reference.

Table two:

No.	Content	Instructions
1	Manufacturer/ supplier	Not brand
2	Figure /icon/ mark	Detail in table one
3	Connect to main power	Detail in power specification
4	Power frequency, Hz	Detail in power specification
5	Input power frequency	Detail in power specification
6	Network output power	N/A
7	Classification	Detail in table one item 3
8	Working time	No indication, work continuously
9	Fuse	Detail in table one item 11
10	Output	Detail in table one item 9
11	Physiological reaction	No indication. N/A
12	AP/ AGP type device	No indication. N/A
13	High pressure terminal device	No indication. N/A

14	Cooling condition	No indication. N/A
15	Mechanical stability	No indication. Detail in Precaution item 8.
16	Protective packing	Transportation marks required by <EN ISO 780-1997 packing-handling icon marks > are affixed to the outer packing carton, which includes up, fragile, afraid of the rain, stacking Limit, stacking weight limit and so on.

Marks on device

The marks on power box of slit lamps.

Table 3

No.	Content	Instructions
1		Protective Earth Terminal

Indicator lamp

There is indicator lamp on power switch. Green light indicates the power is on, and the instrument is working.

2. Installation of the instrument and working condition

Slit lamps are network powered medical instrument. Please check per the checking list after opening the carton and install the instrument according to this user manual. Test and ensure the instrument operating well before putting to use.

2.1 Replacements of fuse and other consumables

2.1.1 Replacement of fuse

The rated value of fuse for this instrument is indicated in table one item 11. And the specification of fuse is also marked on the power box (detail in Chapter 4.6). Spare fuses are provided with this instrument. For more fuses, purchase from your local supplier.

2.1.2 Replacement of other consumables

Detail in Chapter 4 of this manual.

3. Electrical circuit drawing and component list

3.1 Electrical circuit drawing

Detail in appendix A.

3.2 Component list

The following electronic components are used in this instrument.

Table 4

No.	Component name
1	Annulus transformer
2	Light dimmer potentiometer
3	SCR circuit boards
4	Power switch with indicator
5	Metal output socket with four pins
6	220V/110V input voltage selector
7	Network power input socket
8	Light source (halogen/ LED lamp)
9	Fixation target
10	fuse
11	Protective earth terminal

3.3 Transport Storage Environmental Limits

No special requirements besides the content about transportation and storage of IEC 60601-1-2005 standard.

Contents

EMC PRECAUTIONS:	6
 WEEE PRECAUTIONS:	6
1) NOMENCLATURE	10
2) ASSEMBLY	13
2.1 MAIN PARTS CHECK LIST	13
2.2 ASSEMBLY PROCEDURE	14
2.3 CHECKING PROCEDURE	16
3) OPERATION PROCEDURES	17
3.1 PREPARATION FOR DIOPTER COMPENSATION AND IPD ADJUSTMENT	17
3.2 PATIENT POSITION AND THE USE OF FIXATION TARGET	18
3.3 BASE OPERATION.....	18
3.4 OPERATION OF ILLUMINATION SYSTEM.....	18
3.5 TIPS OF OPERATION PROCESS	19
4) CLEANING AND DISINFECTION:	19
4.1 METHOD OF CLEANING AND DISINFECTION	19
4.2 CLEANING CIRCLE	20
4.3 MAINTENANCE.....	20
4.4 PROTECTION.....	20
4.5 REPLACING THE ILLUMINATION BULB	20
4.6 REPLACING THE FUSE	21
4.7 REPLACING THE CHIN-REST PAPER	22
4.8 CONSUMABLES.....	22
5. TROUBLE SHOOTING GUIDE	23
APPENDIX	24

1. Nomenclature

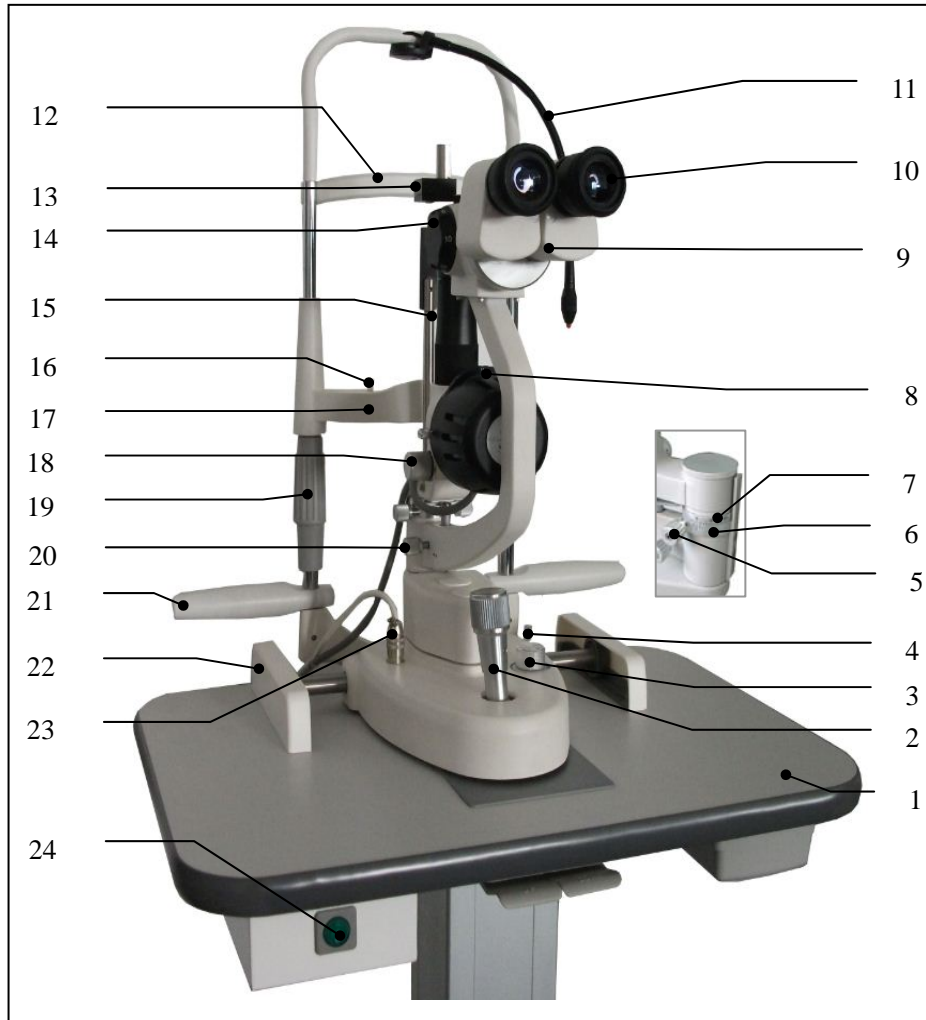

1. Work Tabletop
2. Joysticks
Incline joystick to move the instrument slightly on the horizontal surface and rotate it to adjust the elevation of the microscope.
3. Brightness Control knob
Avoid working continuously at high brightness or the service life of the bulb will be shortened.
4. Base Locking Screw
The base will be locked when fastening this screw.
5. Illumination Arm Locking Knob
When locking the screw, the illumination system and checking system were connected, when loosening it the illumination system can be used separately.
6. The mark line on the ring of the microscope arm.
Together with (6) to indicate the angle between the microscope and illumination unit
7. The indicate of relative angle between the microscope and illumination unit
Mark on the angle mark ring of the illumination arm, which relates to the long mark of the microscope arm, represent the two arms' angle when the "0" on the ring relates to the short mark at one side of the operator the right eyepiece may be blocked, and the side of the patient the left eyepiece.
8. The dial of Aperture Slit Height & the dial of Filter Selection
Dial it; there are a few slit heights for selection. Dial it, there are four kinds of filters for selection.
9. Prism Box
Separate the prism box to adjust the interpupillary distance.
10. 12.5X Eyepieces
11. Fixation target
Let the patient stare at it and make the patient's eyes being observed in a stationary state
12. Forehead Belt
Make patient's head in an appropriate position
13. Applanation tonometer adapter
14. Magnification Select Dial
Dial it, three different magnification are provided
15. Focusing test rod
In order to focus.
16. The Fixation Knob of Chin-rest Paper
It is used to fix the chin-rest paper.
17. Chin-rest
Supporting the patient's chin
18. Slit Width Control Knob

The slit width is continuously adjustable within the range from 0 to 14mm. The marks on the left knob stands for the approximant value of the width.

19. **Chin-rest Elevation Adjustment Knob**
Rotate the knob to adjust the elevation of the chin-rest
20. **Microscope Arm locking screw**
21. **Handle (optional accessories)**
22. **Rail Cover**
23. **Access line and plug of the brightness control**
24. **Main Power Switch**
Turn on the switch, the mark lamp will light

2. Assembly

All parts should be taken out with great care from the packing case before assembling.

2.1 Main parts check List

No.	Mark	Name	Quantity	Note
1	A	Chin-rest part	1	Fig.2.1.1
2	B	Microscope part	1	Fig.2.1.2
3	C	Illumination part	1	Fig.2.1.3
4	D	Tabletop part	1	Fig.2.1.4
5	E	Rail cover	1	Fig.2.1.5
6	F	Power cable	1	
7	G	Focusing test rod	1	Fig.2.1.6
8	H	Dust-proof cover	1	
9	I	Chin-rest paper	1	
10	J	Screw driver	1	
11	L	User manual	1	
11	M	Packing list	1	

Drawing:

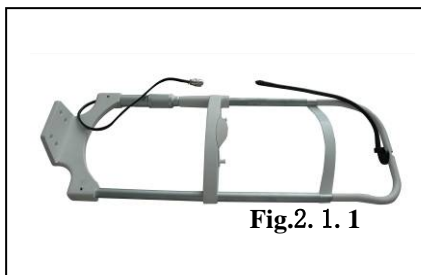

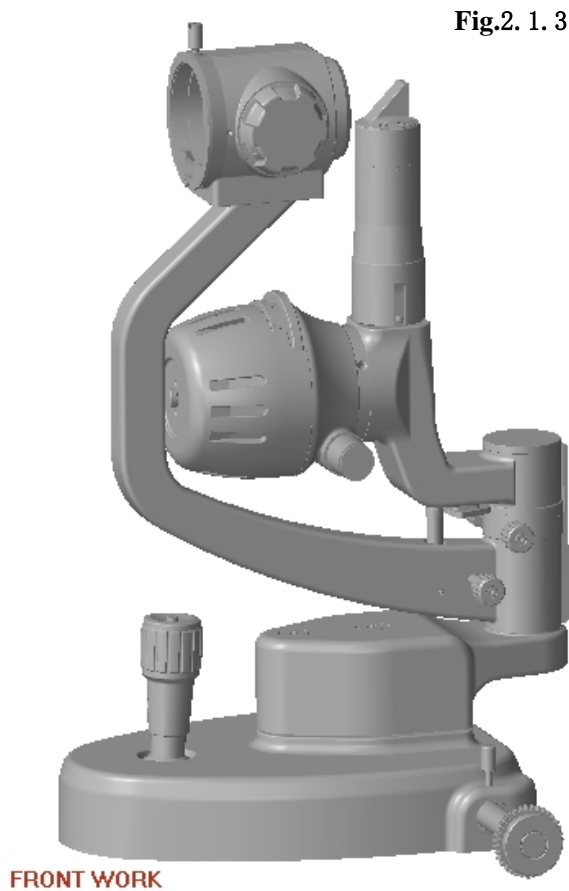

Fig.2. 1. 3

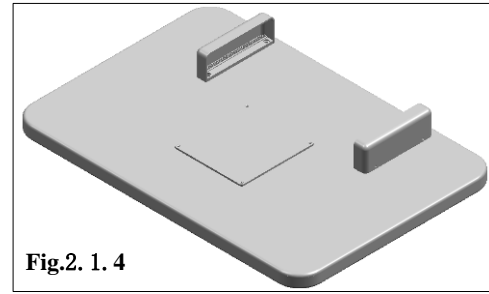

Fig.2. 1. 4

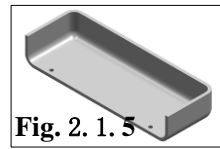

Fig.2. 1. 5



Fig.2. 1. 6

- Remove A team screws (4*M6 x20mm) under the tabletop.(Fig.2.2.1 A Team).

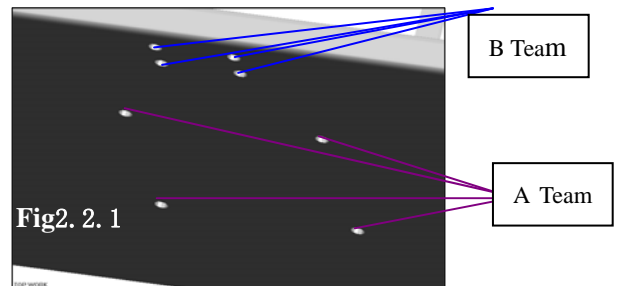

Fig.2. 2. 1

2.2 Assembly procedure

- Open the carton, and take out the tools: cross screw driver and spanner.
- Check the setting on the voltage selector located on the bottom of the power box according to local network voltage. We provide two voltage options: 220V/110V.
- A **F1A1250V** fuse has been inserted into the power box. Spare fuse are provided in the carton.

- Lift the tabletop to align its screw holes to the assembly holes of the instrument table. (Fig.2.2.2)
- Fix the tabletop with the power switch facing to the operator. (Fig.2.2.2)

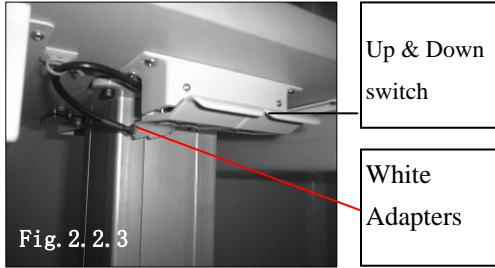

Fig.2.2.2



The screws to connect with the electrical table

7. Connect two white adapters under table board. Turn on and press Up & Down switch to check whether the power table works well. (Fig.2.2.3)



8. Remove the four screws of B Team with screw drive, and fix the chin-rest part to the tabletop in the way as the following picture shows. (Fig. 2.2.4)

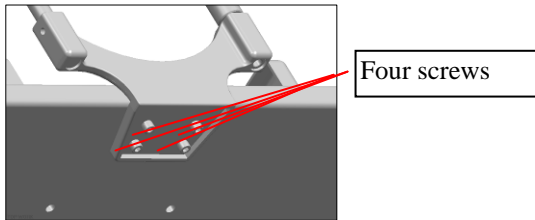

Fig 2.2.4

9. Take out the slit lamp part, put it on the rails of the tabletop, and ensure the gears well connected. Move the base to confirm the wheels rolling steadily and then cover the rails with rail covers. (Fig.2.2.5 and 2.2.6).

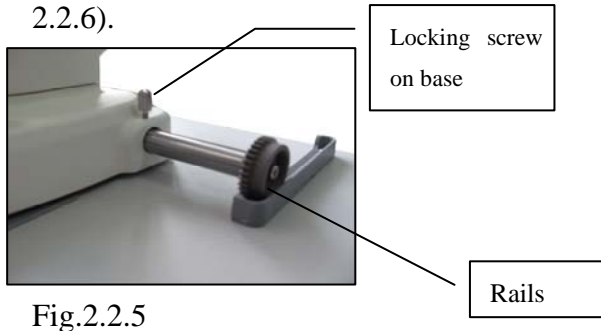

Fig.2.2.5



Fig.2.2.6

10. Take out the binocular tubes of microscope part (Fig.2.1.2), match the groove on the binocular tubes with the pin on the microscope body. Fasten the fixing screw on the body to the microscope. **Attentions: Don't touch the objective lens and eyepieces during assembling.**

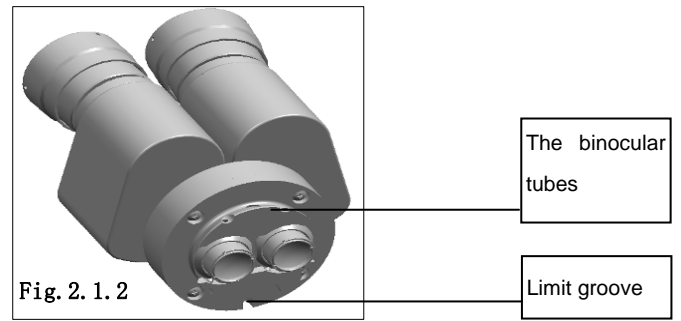

Fig. 2. 1. 2

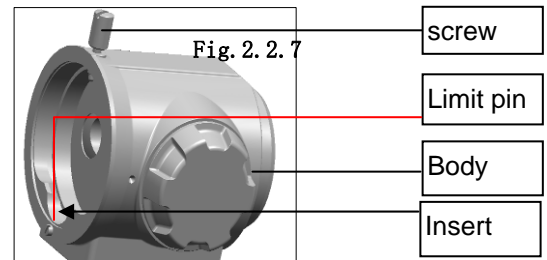

Fig. 2. 2. 7

11. Make sure the main power plug is not connected (fig.2.2.9). Take out the wire of brightness control knob on the base and connect it to the corresponding socket on the power box. Insert the plug of chin-rest bracket in the correct socket, and fasten it.

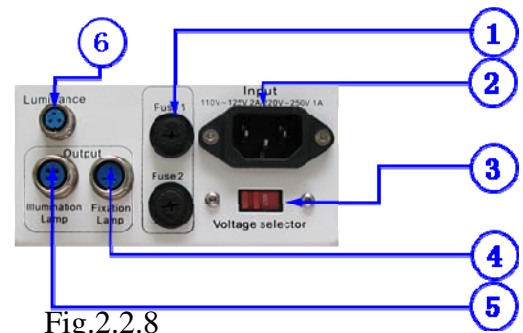
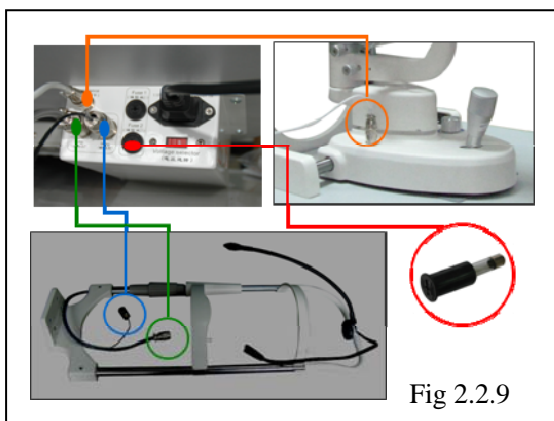

Fig.2.2.8

1. Fuse box
2. Power socket
3. 110V/220V voltage selector
4. Fixation lamp socket
5. Illumination lamp socket
6. Brightness control knob socket



12. Check the voltage selector, this power box support working under the voltage of 110V and 220V. Please select the right voltage according to the voltage in your country.

There is a limit groove on the socket. Please align the plug with the groove.

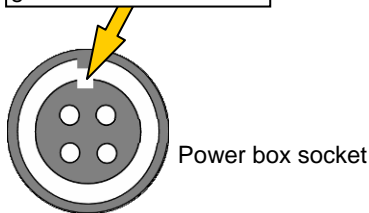

⚠ Caution: Wrong power selection may lead to damage of the instruments.

13. Open the fuse box and make sure there is a fuse assembled.

Specification of the fuse: **F1AL250V**

14. Collect tools and spare parts and put them into the drawer under the right side of tabletop.

2.3 Checking procedure

15. A 3 pin cable is supplied with this instrument. Correct plug is supplied as well. Ensure the instrument is grounded.
16. Marks on the power switch: “I” means power on and “O” means power off. **The main power switch should be set at the ‘O’ position before connecting the input cable with the power socket.**
17. The indicator lamp will be lighted when the instrument is power on (Fig.3.1.3).
18. Insert the focus test rod to right position. A light spot will be projected on the focus test rod. Rotate the slit width knob to adjust the width of the spot and the light dimmer to adjust its brightness.
19. The fixation target is lighted (Fig.3.2.1)
20. Check the following part works flexibly:
 - Aperture changer (Fig.2.3.1)
 - Slit width control knob (Fig.2.3.1)
 - Filter selector (Fig.2.3.1)
 - Joy stick (Fig.2.3.3)
 - Magnification changer lever (Fig.2.3.2)

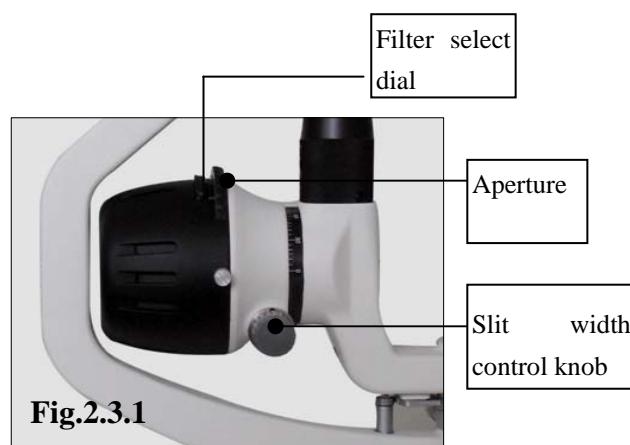

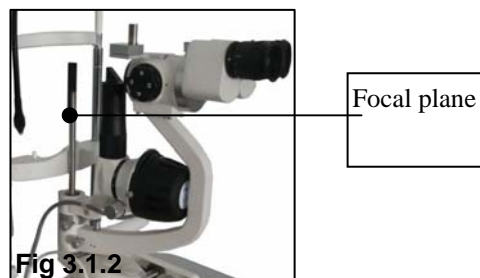
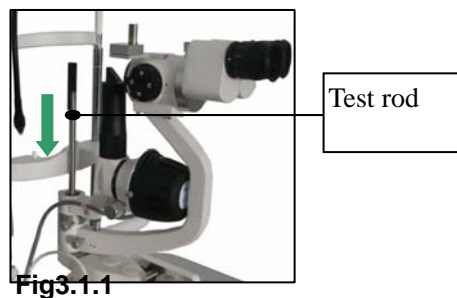
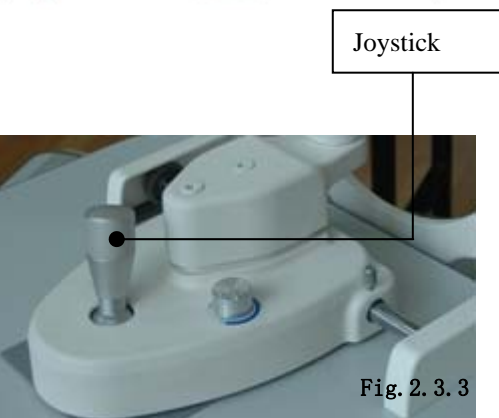
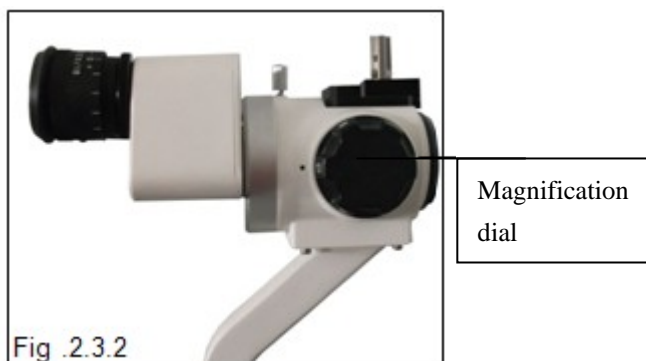

21. Rotate the light dimmer knob (Fig.3.1.3) and the brightness will go dim.
22. Turn off the main power and cover the instrument with the dust-proof cover after testing.

3. Operation procedures

3.1 Preparation for diopter compensation and IPD adjustment

① Use of the focusing test rod

The rod is a standard accessory for accurate adjustment of the microscope. Insert it into the correct position of slit lamp. With the focal plane facing to the objective lens (Fig.3.1.1 & 3.1.2).

Attention : Remove the rod after testing.

② Brightness adjustment

Switch on the main power. Rotate the light dimmer to the central position (Fig.3.1.3). Set the slit width at 2~3mm (Fig.2.3.1).

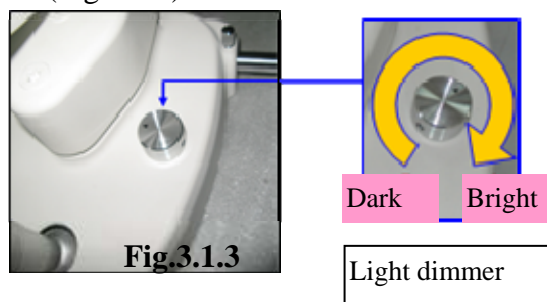

③ Adjustment of Diopter compensation

The focus plane of microscope is calibrated according to the emmetropia. If the operator is ametropia, he should adjust the eyepiece diopter (Fig.3.1.4) according to the following procedures: First, rotate the diopter adjustment ring counter-clockwise to the end.

Second, rotate the ring clockwise until the slit image is sharp. Adjust the other eyepiece in the same way.

If necessary, record the diopter value on each eyepiece for future reference.

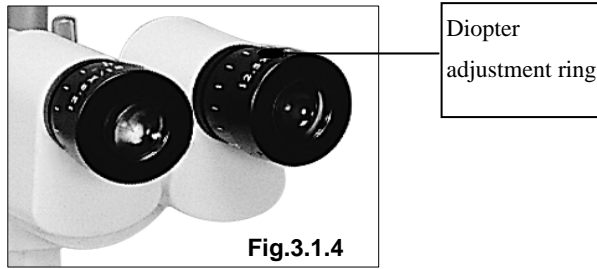

④ IPD adjustment

Separate the prism box of the microscope to adjust the P.D to get a stereo vision through the microscope (Fig.3.1.5).



3.2 Patient position and the use of fixation target

- 1) The patient should put chin on the chin-rest and push forehead against the forehead belt. Adjust the elevation of chin-rest until the light of slit lamp projects to the correct position of patient's eye. (Fig.3.2.1).
- 2) The fixation target is used to attract patient's attention. Move the tube to put the fixation target at a proper position (Fig.3.2.1).

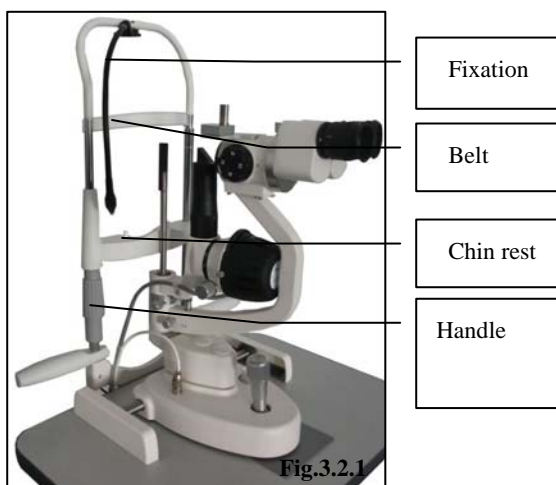

3.3 Base operation

1) Horizontal rough adjustment

Move the base back and forth to align microscope with patient's eye (Fig.3.3.1).

2) Vertical adjustment

Rotate the joystick to adjust the microscope's height until it is perfect to observe the patient's eye. Rotate the joystick clockwise to raise the microscope and counter-clockwise to lower it (Fig.3.3.1).

3) Horizontal Fine adjustment

Tilt the joystick to move the microscope slightly on the horizontal surface and watch through the eyepieces until a clear and sharp image appear on the field (Fig.3.3.1).

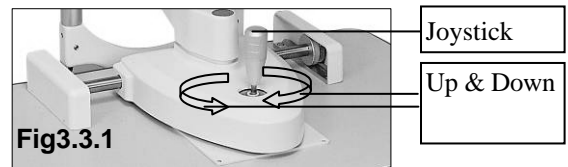

4) Locking the base

When finishing the adjustment, fasten the base locking screw to lock the base and prevent it from sliding. (Fig.3.3.2)

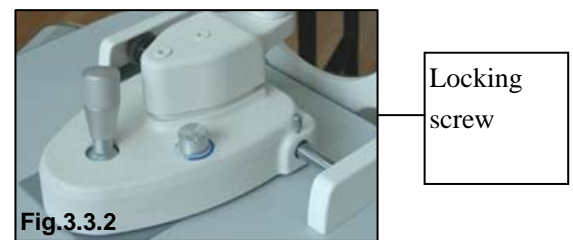

3.4 Operation of illumination system

1) Changing the aperture and slit height

Rotate the aperture and slit height dial to get four round light spots of different diameter sizes: 14mm,

8mm, 3.5mm, and 0.5mm. Besides the round spot, a wedge-shaped continuous slit spot will be got, whose length is from 1mm to 14mm. The value can be read on the aperture dial (Fig.3.4.1).

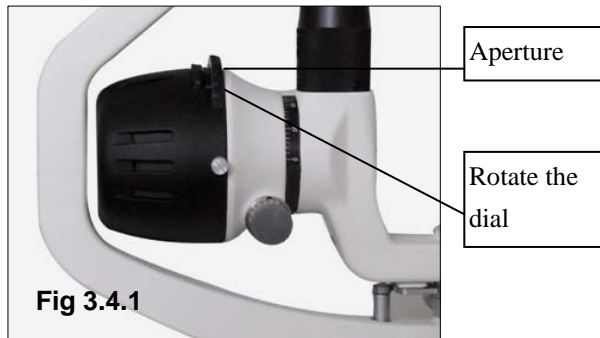

2) Rotating the slit image

Swing the aperture and slit height control knob horizontally to revolve the slit image at any angle from vertical to horizontal direction. The angle of image rotation is indicated by the rotation angle scale with small division for 5° and large division for 10°(Fig.3.4.2).

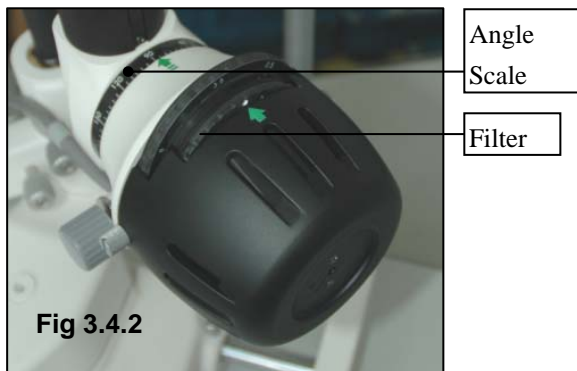

3) Filter selection

By rotate the filter dial, three different filters are provided. For general observations, the heat-absorbing filter is placed in position. Set the heat-absorbing filter in position after using the other filters (Fig.3.4.2).

3.5 Tips of operation process

1) Read this user manual carefully to learn the structure and function of slit lamp for

using the instrument properly.

- 2) In order to prevent the unnecessary observation misjudgment, read the scales on each knob carefully.
- 3) Operator should adjust the inter-pupillary distance and diopter correctly in advance in case feeling uncomfortable during observation.
- 4) Operator may feel dizziness in a long time observation. Take a rest after long time using of the slit lamp.
- 5) The patients' eyes will be exposed to the light of slit lamp. The light should be strong enough for observation. Stop observation, if the patient feels uncomfortable. For serious situation please seek for medical treatment. Therefore, avoid prolonged exposure of patients' eyes in strong light.

4. Cleaning and disinfection:

4.1 Method of cleaning and disinfection

- 1) **Cleaning the lens and reflecting mirror:** If there is any dust on the lenses or reflecting mirror, wipe it off with soft cotton dipped in absolute alcohol (Fig.4.1.1).

⚠Attention: Do not touch the lens with finger or hard object.

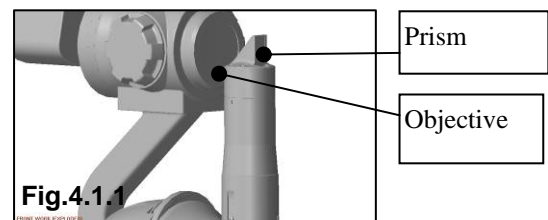

- 2) **Cleaning the sliding pad, rails and shaft:** Clean these parts with clean soft cloth regularly to ensure the stable movement of slit lamp. (Fig.4.1.2).

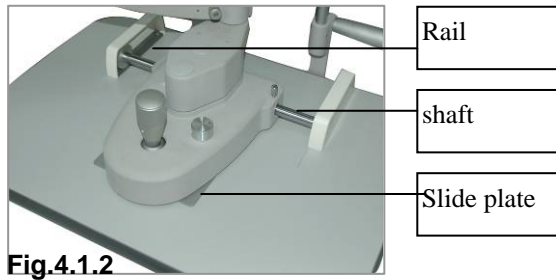

Fig.4.1.2

- 3) **Cleaning and disinfecting the plastic parts:** Clean the plastic parts such as chin-rest bracket, forehead-rest belt with soft cloth dipped in soluble detergent or water, and then disinfect these parts with medicinal alcohol. **Attention: Don't wipe these parts with any corrosive detergent in case any surface damage caused.**

4.2 Cleaning cycle

It required that the slit lamp should be stored and used in a clean environment. For prolong the service life of the instrument please clean it regularly per as suggestions below.

- 1) Clean the eyepieces, objective lens and reflecting mirror:
Cycle: suggested once per two months.
The lenses and mirror are coated with antireflection coating and the reflective film. Although the coating is strong enough, frequent wipe will lead to damage to the film, and thus affect the observed optical effect.
- 2) Cleaning the slide pad, rails and shaft:
Cycle: suggested once per month
Usually, these parts won't get dirty in normal use. We suggest cleaning these parts once per 6 months for getting smoother movement experience.
- 3) Cleaning the plastic parts:
Cycle: suggested once per day
These two parts contact with the patients directly, so please clean and disinfect these two parts timely. Replace a piece of new and clean chin-rest paper for each

patient.

- 4) Cleaning the whole machine:

Cycle: suggested once per two months.

Life cycle of the slit lamp: 4 years.

4.3 Maintenance

Correct and periodical protection and maintenance will prolong the service life of the slit lamp. The suggested maintaining cycle is once per two months.

4.4 Protection

Cover the main shaft hole with the protection cap to prevent any dust drop in. Remove the cap when the focus test rod needs to be assembled (Fig.4.4.1).

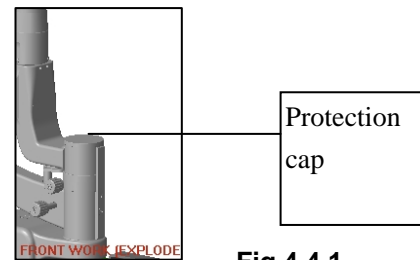

Fig.4.4.1

4.5 Replacing the illumination bulb

Caution: the spring blade and the bulb went very hot after a long time of burning. In case any scald injury happens, do not change the bulb until the illumination system is cooling down.

1. Switch off the main power. (Fig.3.1.3);
2. Remove out the fixation knob. Pull up the lamp cap from the illumination unit.

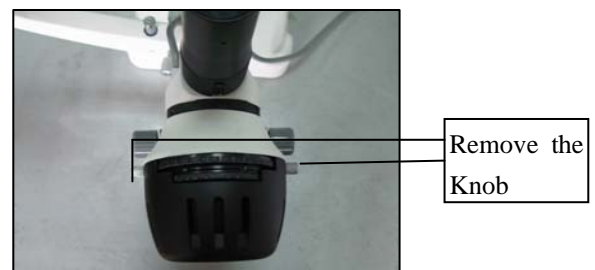

Fig.4.5.1

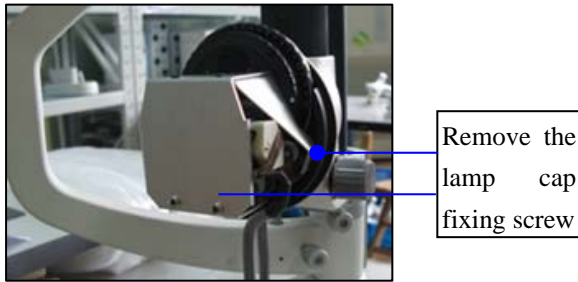

Fig.4.5.2

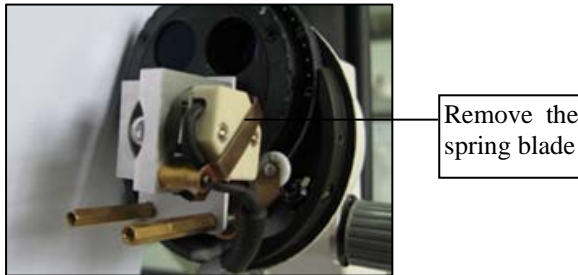

Fig.4.5.3



Fig.4.5.4

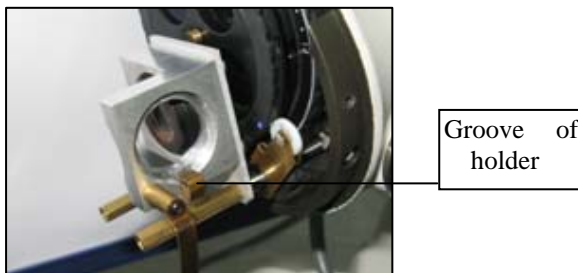

Fig.4.5.5

3. Remove the spring blade (Fig.4.5.2) to take out the original bulb and holder (Fig.4.5.3), and place the new bulb to correct position. Press the spring blade to fix the new bulb.

4. Align the groove on the bulb to the holder; otherwise the illumination may be uneven (Fig.4.5.5). Cover the lamp house with cap and fix the locking screws.

5. Switch on the power and check

whether the new bulb is illuminating, and if the spot is in good shape without false light. (Fig.3.1.3).

4.6 Replacing the fuse

1) Switch off the main power and remove the power cable from socket. (Fig.4.6.1).

2) The fuse is inserted in the fuse box which has fuse mark. Please rotate the fuse part out (Fig.4.6.1) by pressing the fuse box with a screw or a coin. One fuse is in use, the other is in spare. Please check them, if the one in use is burnt, please replace it with the spare one and then place both the two fuse parts into original place.

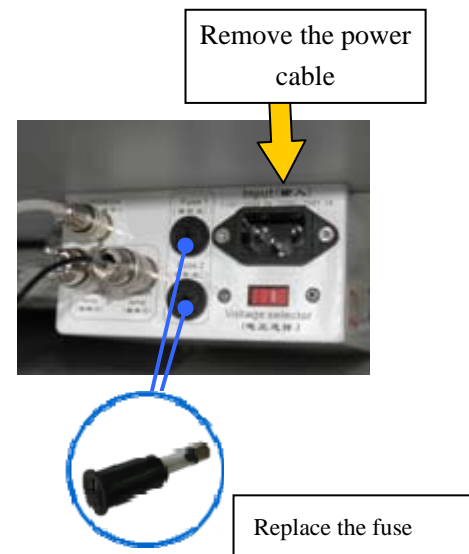

Fig.4.6.1

3) The fuse specification:

F1AL250V

⚠ Attention: Please select fuse of the same type, specification and rate value.

4.7 Replacing the chin-rest paper

Change the chin-rest paper: remove the two fixation bolts and place the new papers. (Fig.4.7.1)

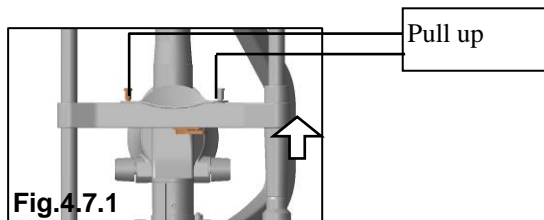

1. Fuse: F1AL250

2. Bulb: 6V20W halogen bulb

Note: The service life of the halogen bulb is 480 hours. However, it can still work beyond the time limit, while the brightness of the bulb might be lower.

5. Trouble shooting guide

In case there is any trouble, please check according to the following table for reference. If it still cannot work, please contact the Repair Department of an authorized distributor.

Trouble	Possible cause	Remedy
No illumination	The cable isn't connected correctly with the power socket	Connect the power cable correctly
	The main power switch is on 'O' position	Place the switch on 'I' position
	The plug on the power box is loosen	Insert the plug firmly
	The plug on the lamp cap is loosen	Insert the plug firmly
	The bulb has burnt out	Change the bulb
	The fuse has blown	Change the fuse
	The bulb is not assembled properly	Assemble the bulb properly
	The filter lever is in the middle position or in the position of gray filter	Set the filter lever to the correct position
the brightness adjustment knob is at min.	the brightness adjustment knob	
Slit is too dark	Voltage selector is wrongly set	Set the voltage selector correctly
	The coat of the reflecting mirror is oxidized	Change the reflecting mirror
	Too much dust on the reflecting surface	Clean the surface with the brush
Fuse has blown	Voltage selector id wrongly set	Set the voltage selector properly
	The fuse doesn't comply with the specification	Replace it with a suitable fuse
Slit width closes automatically	The slit width control knob is too loose	Adjust the tightness of the control knob
Fixation bulb is off	The output plug is loose	Insert the output plug firmly

Appendix Electronic Circle Drawing

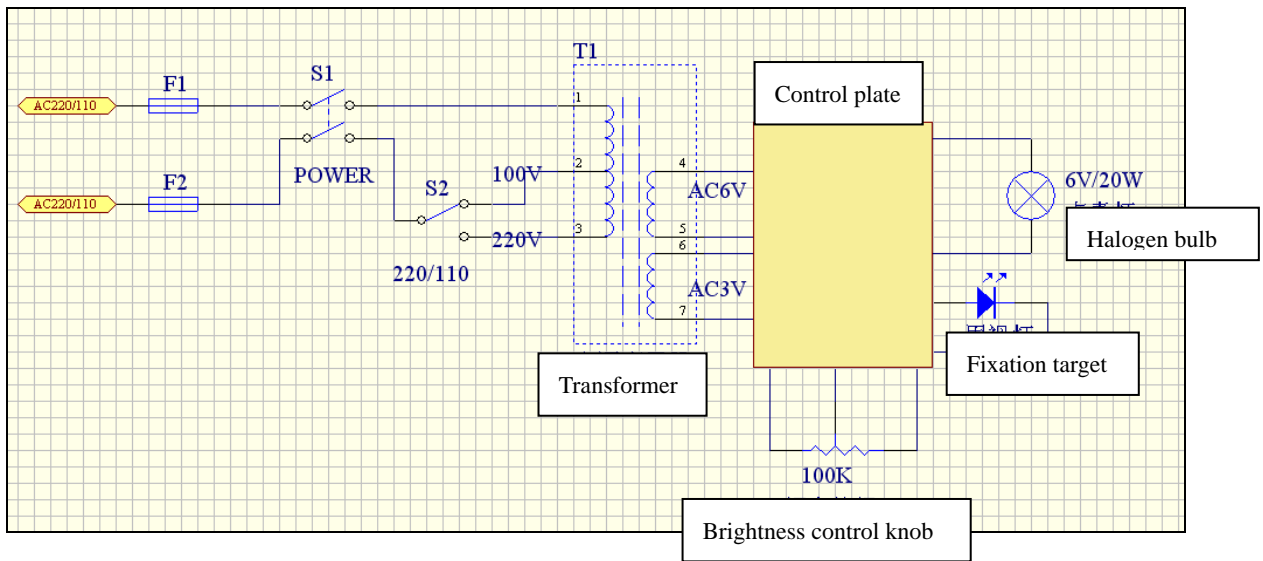

Subject to change in design or specifications without advance notice