

MP-Series Electric Cylinders

Catalog Numbers MPAR-x1 xxxB, MPAR-x1 xxxE,
MPAR-x2 xxxC, MPAR-x2 xxxF, MPAR-x3 xxxE, MPAR-x3 xxxH

Topic	Page
Important User Information	2
Catalog Number Explanation	3
About the MP-Series Electric Cylinders	4
Before You Begin	5
Install the Electric Cylinder	7
Mount the Electric Cylinder	9
Change Connector Orientation	12
Dimensions	13
Connector Data	19
Commissioning	20
Maintenance	32
Troubleshooting	33
Accessories	35
Specifications	39
Additional Resources	44

Important User Information

Solid-state equipment has operational characteristics differing from those of electromechanical equipment. Safety Guidelines for the Application, Installation and Maintenance of Solid State Controls (Publication [SGI-1.1](#) available from your local Rockwell Automation sales office or online at <http://www.rockwellautomation.com/literature/>) describes some important differences between solid-state equipment and hard-wired electromechanical devices. Because of this difference, and also because of the wide variety of uses for solid-state equipment, all persons responsible for applying this equipment must satisfy themselves that each intended application of this equipment is acceptable.





In no event will Rockwell Automation, Inc. be responsible or liable for indirect or consequential damages resulting from the use or application of this equipment.

The examples and diagrams in this manual are included solely for illustrative purposes. Because of the many variables and requirements associated with any particular installation, Rockwell Automation, Inc. cannot assume responsibility or liability for actual use based on the examples and diagrams.

No patent liability is assumed by Rockwell Automation, Inc. with respect to use of information, circuits, equipment, or software described in this manual.

Reproduction of the contents of this manual, in whole or in part, without written permission of Rockwell Automation, Inc., is prohibited.

Throughout this manual, when necessary, we use notes to make you aware of safety considerations.

	WARNING: Identifies information about practices or circumstances that can cause an explosion in a hazardous environment, which may lead to personal injury or death, property damage, or economic loss.
	ATTENTION: Identifies information about practices or circumstances that can lead to personal injury or death, property damage, or economic loss. Attentions help you identify a hazard, avoid a hazard and recognize the consequences.
	SHOCK HAZARD: Labels may be on or inside the equipment, for example, drive or motor, to alert people that dangerous voltage may be present.
	BURN HAZARD: Labels may be on or inside the equipment, for example, drive or motor, to alert people that surfaces may reach dangerous temperatures.
IMPORTANT	Identifies information that is critical for successful application and understanding of the product.

Catalog Number Explanation

Catalog numbers consist of various characters, each of which identifies a specific version or option for that component. Use the catalog numbering chart below to understand the configuration of your actuator.

MP AR - xx xxx x - x x A

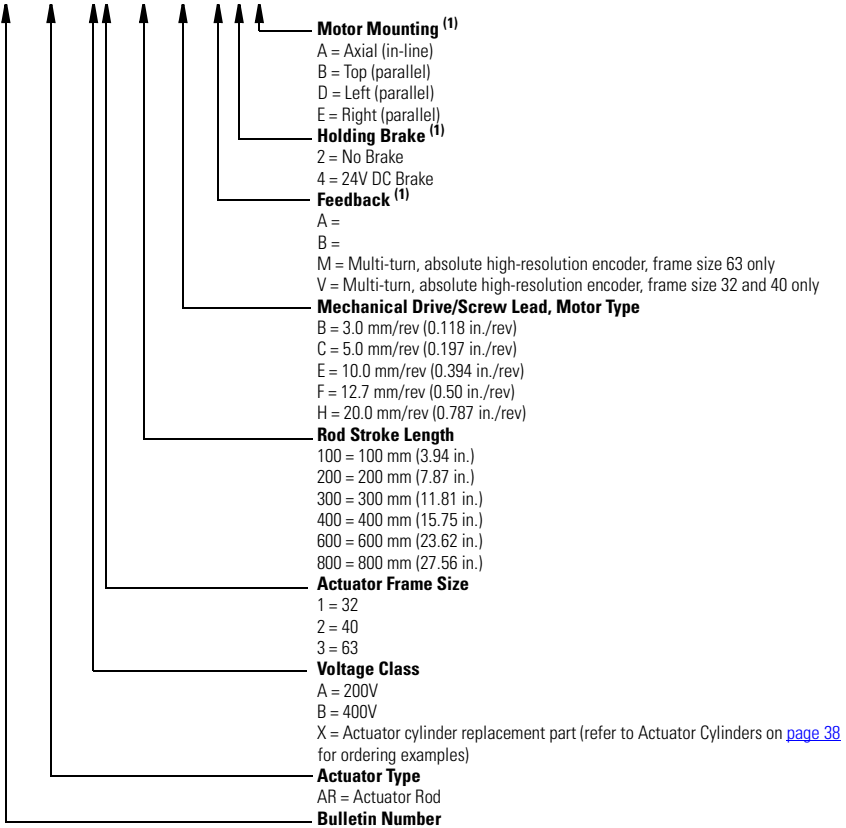

(1) This field does not apply to actuator cylinder replacement parts.

MP AR - xx xxxxxx

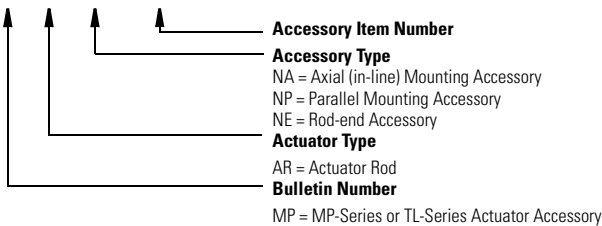

About the MP-Series Electric Cylinders

MP-Series electric cylinders feature multi-turn high resolution encoders and are available with 24V DC brakes. The MP-Series motor rotates a ballscrew drive that converts rotary motion into linear movement. This linear movement results in the piston rod extending and retracting from the electric cylinder housing.

IMPORTANT The MP-A/Bxxxx-x2x electric cylinders are non-braking. When there is no input torque, the piston rod can be moved freely. You can achieve self-locking of your motion system by using motors with an integrated brake or with high self-braking torque.

The MP-Series electric cylinders have been designed for exact positioning at high speeds.

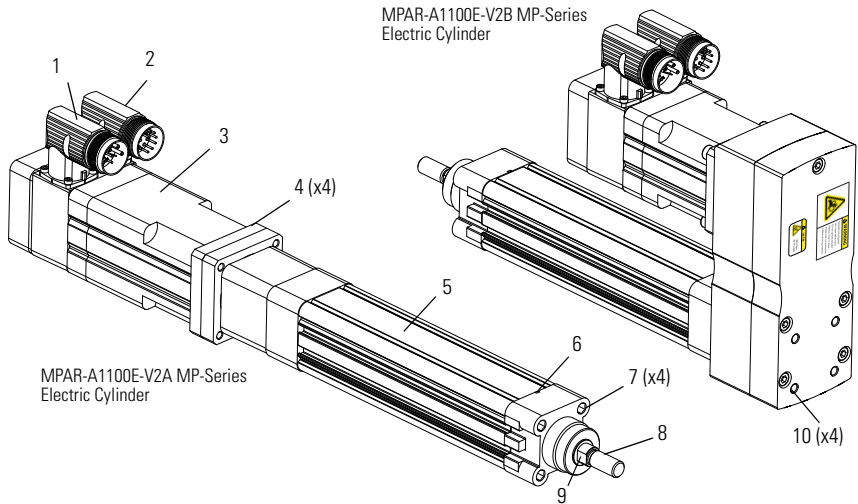

Item	Description
1	Power connector
2	Feedback connector
3	MP-Series motor
4	Motor mounting bolts
5	Actuator cylinder
6	Breather port
7	Hollow bolts with internal treads for fastening
8	Piston rod
9	Wrench flats for counteracting torque on piston rod
10	Accessories mounting holes

Before You Begin

Remove all packing material, wedges, and braces from within and around the item. After unpacking, verify the nameplate catalog number against the purchase order.

1. Remove packaging polyethylene foil and cardboard.
The packing materials are recycleable, except for oiled paper, which is waste.
2. Remove the electric cylinder carefully from its shipping container.
Consider the weight of the electric cylinder. Depending on the design, the electric cylinder can weigh up to 20.6 kg (45.4 lb).
3. Visually inspect the electric cylinder for damage.
4. Examine the electric cylinder frame, piston shaft, and hollow bolts for defects.
5. Notify the carrier of shipping damage immediately.



ATTENTION: Do not attempt to open and modify the electric cylinder beyond changing motor connector orientation as described on [page 12](#). Only a qualified Allen-Bradley employee can service the internal working of the electric cylinder or motor. Failure to observe these safety precautions could result in personal injury or damage to equipment.

Planning Your Installation

Refer to the Kinetix Motion Control Selection Guide, publication [GMC-SG001](#), for the specifications and additional products referenced in this section.

- This product can be operated in compliance with the relevant safety regulations only if the maximum loading limits are observed.
- If you are mounting your electric cylinder in a vertical or sloping position, include safety measures that will control the workload should the spindle nut fail.



ATTENTION: Uncontrolled moving masses can cause injury or damage to property. If there is a spindle nut fracture inside the actuator cylinder due to wear, the working mass will drop down. Check whether additional external safety measures are required to prevent damage in the event of a spindle nut fracture.

- Corrosive environments reduce the service life of electric cylinders.
- Depending on the workload, the piston rod will bend. Refer to the piston-rod deflection specifications for limitations.
- Motor feedback, auxiliary feedback, and I/O connector kits are not included, but can be purchased separately.

- Factory manufactured feedback and power cables are available in standard cable lengths. They provide environmental sealing and shield termination. Contact your Allen-Bradley sales office or refer to the selection guide for cables.

Preventing Electrical Noise

Electromagnetic interference (EMI), commonly called electrical noise, can reduce motor performance. Effective techniques to counter EMI include filtering the AC power, using shielded cables, separating signal cables from power wiring, and practicing good grounding techniques.

Follow these guidelines to avoid the effects of EMI:

- Isolate the power transformers or install line filters on all AC input power lines.
- Physically separate signal cables from motor cabling and power wiring. Do not route signal cables with motor and power wires, or over the vent openings of servo drives.
- Ground all equipment by using a single-point parallel ground system that employs ground bus bars or large straps. If necessary, use additional electrical-noise reduction techniques to reduce EMI in noisy environments.

Refer to System Design for Control of Electrical Noise Reference Manual, publication [GMC-RM001](#), for additional information on reducing the effects of EMI.

Build and Route Cables

Knowledgeable cable routing and careful cable construction improves system electromagnetic compatibility (EMC).

To build and install cables, perform the following steps.

1. Keep wire lengths as short as physically possible.
2. Route signal cables (encoder, serial, analog) away from motor and power wiring.
3. Separate cables by 0.3 m (1 ft) minimum for every 9 m (30 ft) of parallel run.
4. Ground both ends of the encoder cable shield and twist the signal wire pairs to prevent electromagnetic interference (EMI) from other equipment.



ATTENTION: High voltage can be present on the shield of a power cable if the shield is not grounded. Make sure there is a connection to ground for any power cable shield. Failure to observe these safety precautions could result in personal injury or damage to equipment.

Install the Electric Cylinder

The installation must comply with all local regulations and use of equipment and installation practices that promote electromagnetic compatibility and safety.



ATTENTION: Unmounted electric cylinders, disconnected mechanical couplings, and disconnected cables are dangerous if power is applied. Disassembled equipment should be appropriately identified (tagged-out) and access to electrical power restricted (locked-out). Failure to observe these safety precautions could result in personal injury.



ATTENTION: Make sure that cables are installed and restrained to prevent uneven tension or flexion at the cable connectors. Excessive and uneven lateral force at the cable connectors may result in the connector's environmental seal opening and closing as the cable flexes. Failure to observe these safety precautions could result in damage to the electric cylinder motor and its components.



ATTENTION: Damage may occur to the electric cylinder bearings and the feedback device if a sharp impact to the piston rod is applied during installation. Do not strike the piston rod with tools during installation or removal. Do not attempt to rotate the piston rod during installation. Rotating the piston rod will break the mechanism that allows the electric cylinder to extend and retract. Failure to observe these safety precautions could result in damage to the electric cylinder and its components.

Follow these steps to install the electric cylinder.

1. Provide sufficient clearances in the area of the electric cylinder for it to stay within its specified operating temperature range.

Refer to [Specifications](#) on [page 39](#) for the operating temperature range. Do not enclose the electric cylinder unless forced air is blown across the electric cylinder for cooling. Keep other heat producing devices away from the electric cylinder.

IMPORTANT Position the electric cylinder so that all the operating parts are accessible and the breather port is not covered.

2. Make sure the mounting surface supports the electric cylinder evenly so that it is free of mechanical stress and distortion. The evenness of support surface should be ≤ 0.2 mm (0.008 in.).



ATTENTION: Do not modify the settings of the screws and the threaded pins. The electric cylinder must not be fastened by the front cover alone when used with high loads. Heavy tensile strain may cause the screws in the cover to pull out.

3. Attach mounting accessories to the electric cylinder, see [Accessories](#) on [page 35](#).

Tighten the fastening screws evenly.

Attribute	Frame 32	Frame 40	Frame 63
Internal thread of cover screws	M6	M6	M8
Tightening torque, max ⁽¹⁾	5 N•m (3.69 lb•ft)	5 N•m (3.69 lb•ft)	9 N•m (5.90 lb•ft)

(1) Unless otherwise noted, the torque value has a $\pm 20\%$ tolerance.

4. Attach rod-end accessories and the workload.

Be sure the workload center of gravity is centric to the piston rod.



ATTENTION: Damage may occur to the electric cylinder bearings and the feedback device if sharp impact to the piston rod is applied during installation. Do not strike the piston rod with tools during installation or removal. Failure to observe these safety precautions could result in damage to the electric cylinder and its components.

IMPORTANT

Do not twist or rotate the piston rod. If the piston rod is rotated, the absolute position of the electric cylinder will be lost and the absolute home position must be re-established.

When fastening a rod-end accessory or workload to the piston rod, use two wrenches. Use one wrench to tighten the mounting nut or rod-end accessory and the other, on the piston-rod wrench flats, to counteract the applied torque. Be sure that the torque is not applied to the piston rod and that the piston rod does not rotate.

Frame Size	Piston Rod Thread	Wrench Flats Width
32	M10 x 1.25	10 mm
40	M12 x 1.25	13 mm
63	M16 x 1.5	17 mm

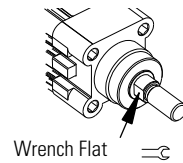

ATTENTION: Do not rotate the piston rod during installation. Rotating the piston rod will break the mechanism that lets the electric cylinder extend and retract. Use two wrenches to install the workload. Failure to observe these safety precautions could result in damage to the electric cylinder 1 and its components.



If you are using a coupling piece attachment, catalog number MPAR-NE3612x, or trunnion mounting kit, catalog number MPAR-NA1635xx, see Accessories on [page 35](#) for torque values.

If you are using a rod guide accessory, catalog number MPAR-NE34xxx or MPAR-NE150xxx, adjust the guides of the workload and the electric cylinder so that they are exactly parallel. This avoids excessive wear on the guide.

Mount the Electric Cylinder

1. Use stainless steel fasteners to mount your electric cylinder to your application.
2. Attach power and feedback cables after the electric cylinder is mounted, and use a drip loop in the cable to keep liquids away from the connectors.



BURN HAZARD: Outer surfaces of the motor can reach high temperatures, 65 °C (149 °F) during electric cylinder operation. Take precautions to prevent accidental contact with hot surfaces. Failure to observe these safety precautions can result in personal injury.



ATTENTION: Consider electric-cylinder surface temperature when selecting motor-mating connections and cables. Failure to observe these safety precautions can result in personal injury or damage to equipment.



ATTENTION: Keyed connectors must be properly aligned and hand-tightened the recommended number of turns. Improper connector alignment is indicated by the need for excessive force, such as the need for the use of tools, to fully seat connectors. Failure to observe these safety precautions could result in damage to the motor and cable, and their components.

Attach Motor Cables

Use this procedure to attach the power and feedback cables after the electric-cylinder is mounted.



ATTENTION: Consider electric-cylinder surface temperature when selecting motor-mating connections and cables. Failure to observe these safety precautions can result in personal injury or damage to equipment.

1. Carefully align each cable connector with the respective motor connector as shown in the following diagram.



ATTENTION: Keyed connectors must be properly aligned and hand-tightened the recommended number of turns. Improper connector alignment is indicated by the need for excessive force to seat connectors. For example, the need to use tools to fully seat connectors. Failure to observe these safety precautions can result in damage to equipment.

IMPORTANT For cables on frame 32 and 40 electric cylinders, leave the O-ring in the groove immediately adjacent to the body of the motor connector.

For cables on frame 63 electric cylinders, remove the O-ring from the motor connector.

2. Fully seat the feedback connector and the power/brake connector.
 - For frame size 32 or 40 electric cylinders, hand tighten the collar 5 to 6 turns.
 - For frame size 63 hand tighten the collar one-quarter turn.

Top of connector is relative to motor orientation.

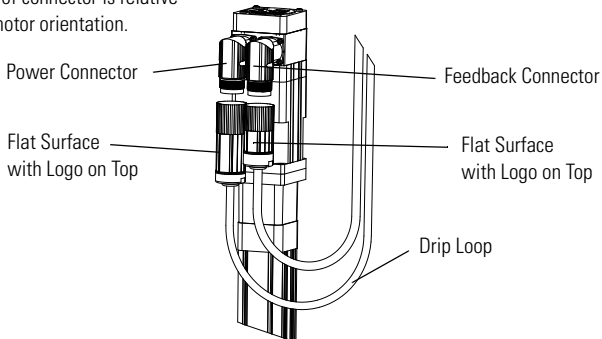

ATTENTION: Make sure that cables are installed and restrained to prevent uneven tension or flexion at the cable connectors. Excessive and uneven lateral force at the cable connectors may result in the connector's environmental seal opening and closing as the cable flexes.

Failure to observe these safety precautions can result in damage to the electric-cylinder motor and its components.

3. Form a drip loop in the cable to keep liquids away from the connectors.
4. Verify the continuity and functionality of the thermal switch signals, TS+ and TS-.

These signals are transmitted through the feedback cable that connects the motor to its controlling drive.

Change Connector Orientation

You can rotate the circular DIN-connector housings up to 180 degrees in either direction.



ATTENTION: You can rotate the connectors into a fixed position during installation of the electric cylinder and keep in that position without further adjustment. Strictly limit the applied forces and the number of times the connector is rotated to be sure that connectors meet the requirements of IP66 for the motor portion of the electric cylinder.

Failure to observe these safety precautions can result in damage to the motor and its components.

Follow these steps to rotate the DIN connectors.

1. Mount and fully seat a mating cable on the connector.
2. Grasp the connector and cable plug by their housings and slowly rotate them to the outside of the motor.

If necessary, repeat this step for each connector (feedback or power/brake).



ATTENTION: Apply force only to the connectors; do not apply force to the cable. No tools (for example, pliers and vise-grips) should be used to assist with the rotation of the connector.

Failure to observe these safety precautions can result in personal injury or damage to equipment.

Dimensions

MP-Series Electric Cylinders (frame 32)

Dimensions are in mm (in.)

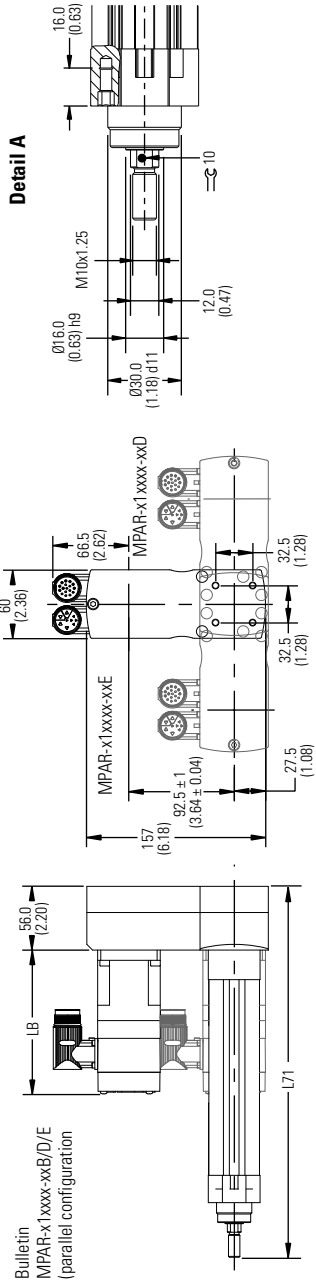
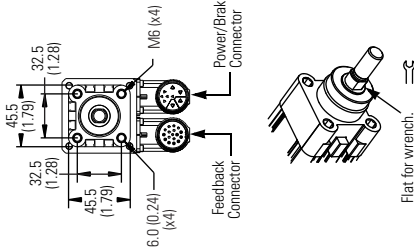
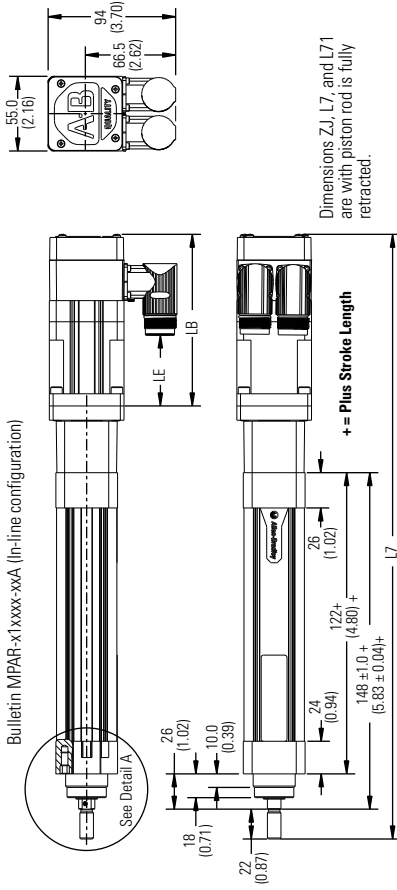

MP-Series Electric Cylinder Dimensions (in-line configuration, frame 32)

Electric Cylinder Cat. No.	L7 ⁽¹⁾ mm (in.)	LB ⁽¹⁾ mm (in.)	LE ⁽²⁾ mm (in.)
MPAR-x1100B-V2A	445.7 (17.55)	126.5 (4.98)	52.4 (2.06)
MPAR-x1200B-V2A	545.7 (21.48)		
MPAR-x1300B-V2A	645.7 (25.42)		
MPAR-x1400B-V2A	745.7 (29.36)		
MPAR-x1100E-V2A	470.7 (18.53)	151.5 (5.96)	77.2 (3.04)
MPAR-x1200E-V2A	570.7 (22.47)		
MPAR-x1300E-V2A	670.7 (26.41)		
MPAR-x1400E-V2A	770.7 (30.34)		

(1) If you are ordering MPAR-x1.xxx-V4x actuator with brake, add 36.1 mm (1.42 in.) to dimensions L7 and LB.

(2) If you are ordering MPAR-x1.xxx-V4x actuator with brake, add 33.4 mm (1.31 in.) to dimension LE.

MP-Series Electric Cylinder Dimensions (parallel configuration, frame 32)⁽¹⁾

Electric Cylinder Cat. No.	L71 mm (in.)
MPAR-x1100B-V2B/D/E	326.0 (12.8)
MPAR-x1200B-V2B/D/E	426.0 (16.8)
MPAR-x1300B-V2B/D/E	526.0 (20.7)
MPAR-x1400B-V2B/D/E	626.0 (24.6)

(1) For complete dimensions of the parallel configuration electric-cylinders use the in-line dimensions for an electric cylinder with the same rod-stroke length and the dimensions from this table.

MP-Series Electric Cylinders (frame 40)

Dimensions are in mm (in.)

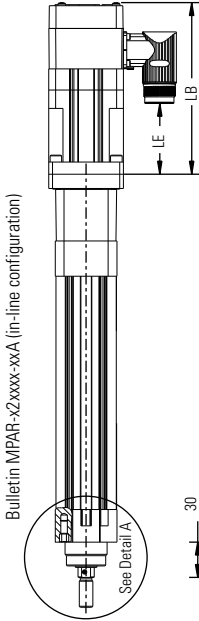
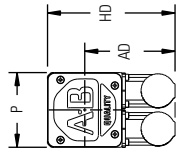

Bulletin MPAF-x2xxx-xxA (in-line configuration)

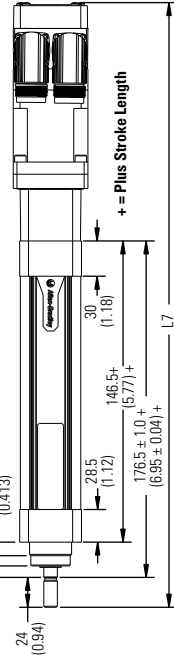
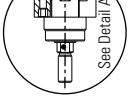

Dimensions Z₁, L7 and L71 are with piston rod is fully retracted.

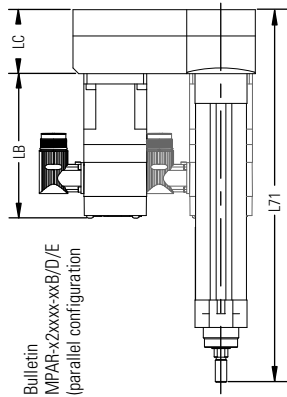
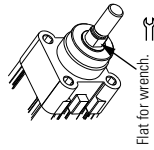
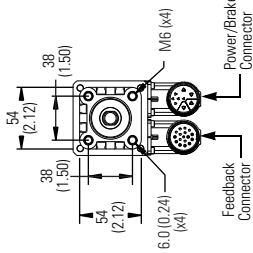

Bulletin MPAF-x2xxx-xxB/D/E (parallel configuration)

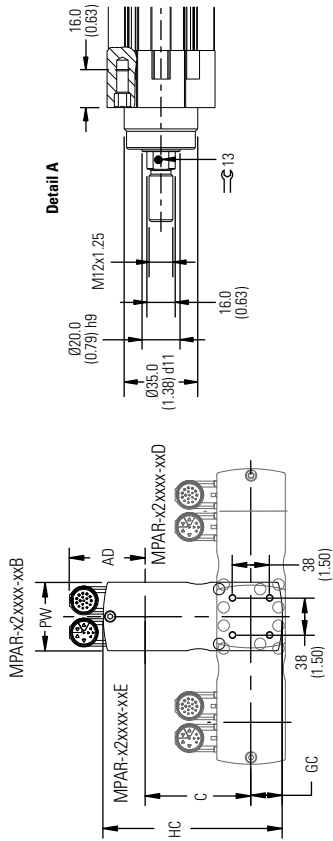

Detail A

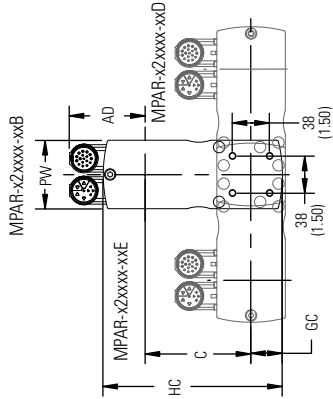

MP-Series Electric Cylinder Dimensions (in-line, frame 40)

Electric Cylinder Cat. No.	L7 ⁽¹⁾ mm (in.)	LB ⁽¹⁾ mm (in.)	LE ⁽²⁾ mm (in.)	P mm (in.)	AD mm (in.)	HD mm (in.)
MPAR-x2100C-V2A	501.2 (19.73)	151.5 (5.96)	77.2 (3.04)	55.0 (2.17)	66.5 (2.62)	94.0 (3.70)
MPAR-x2200C-V2A	601.2 (23.67)					
MPAR-x2300C-V2A	701.2 (27.61)					
MPAR-x2400C-V2A	801.2 (31.54)					
MPAR-x2600C-V2A	1001.2 (39.42)					
MPAR-x2100F-V2A	492.1 (19.37)	140.1 (5.52)	65.1 (2.56)	70.0 (2.76)	74.0 (2.91)	109.0 (4.29)
MPAR-x2200F-V2A	592.1 (23.31)					
MPAR-x2300F-V2A	692.1 (27.25)					
MPAR-x2400F-V2A	792.1 (31.19)					
MPAR-x2600F-V2A	992.1 (39.06)					

- (1) If you are ordering an MPAR-x2xxxC-V4x actuator with brake, add 36.1 mm (1.42 in.) to dimensions L7 and LB. If you are ordering an MPAR-x2xxxF-V4x actuator with brake, add 39.0 mm (1.54 in.) to dimensions L7 and LB.
- (2) If you are ordering an MPAR-x2xxxC-V4x actuator with brake, add 33.4 mm (1.31 in.) to dimension LE. If you are ordering an MPAR-x2xxxF-V4x actuator with brake, add 24.7 mm (0.97 in.) to dimension LE.

MP-Series Electric Cylinder Dimensions (parallel, frame 40)⁽¹⁾

Electric Cylinder Cat. No.	L71 mm (in.)	LC mm (in.)	HC mm (in.)	C ⁽²⁾ mm (in.)	CG mm (in.)	PW mm (in.)
MPAR-x2100C-V2B/D/E	501.2 (19.73)	56.0 (2.20)	157.0 (6.18)	91.5 (3.60)	27.0 (1.06)	60.0 (2.36)
MPAR-x2200C-V2B/D/E	601.2 (23.67)					
MPAR-x2300C-V2B/D/E	701.2 (27.61)					
MPAR-x2400C-V2B/D/E	801.2 (31.54)					
MPAR-x2600C-V2B/D/E	1001.2 (39.42)					
MPAR-x2100F-V2B/D/E	492.1 (19.37)	69.0 (2.72)	188.5 (7.42)	102.5 (4.035)	38.0 (1.50)	86.0 (3.38)
MPAR-x2200F-V2B/D/E	592.1 (23.31)					
MPAR-x2300F-V2B/D/E	692.1 (27.25)					
MPAR-x2400F-V2B/D/E	792.1 (31.19)					
MPAR-x2600F-V2B/D/E	992.1 (39.06)					

- (1) For complete dimensions of the parallel configuration electric-cylinders use the in-line dimensions for an electric cylinder with the same rod-stroke length and the dimensions from this table.
- (2) The tolerance for this dimension is ±1.0 mm (0.04 in.)

Actuators are designed to metric dimensions. Inch dimensions are approximate conversions from millimeters. Dimensions without tolerances are for reference.

MP-Series Electric Cylinders (frame 63)

Dimensions are in mm (in.)

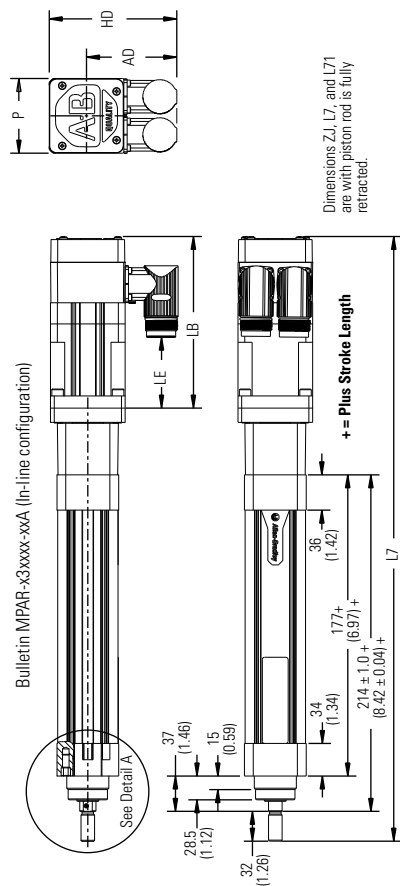

Bulletin MPAR-x3xxx-xxA (in-line configuration)

Dimensions Z1, L7, and L71 are with piston rod is fully retracted.

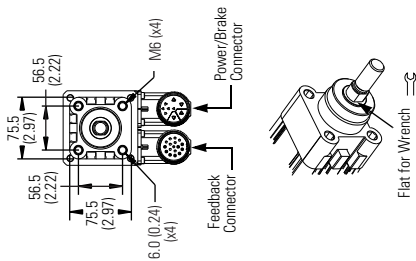

Flat for Wrench ≡

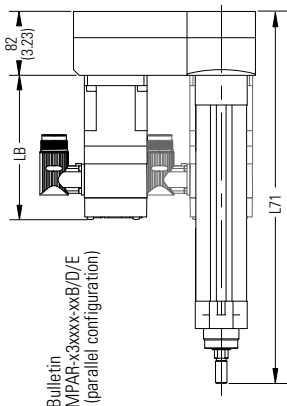

Bulletin MPAR-x3xxx-xxB/D/E (parallel configuration)

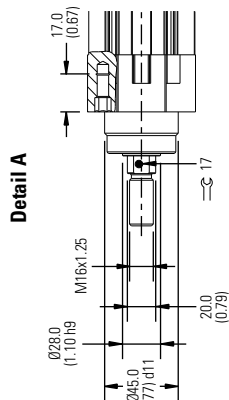

Detail A

MP-Series Electric Cylinder Dimensions (in-line, frame 63)

Electric Cylinder Cat. No.	L7 ⁽¹⁾ mm (in.)	LB ⁽¹⁾ mm (in.)	LE ⁽²⁾ mm (in.)	P mm (in.)	AD mm (in.)	HD mm (in.)
MPAR-x3100E-M2A	603.8 (23.77)	178.8 (7.04)	121.5 (4.78)	89.4 (3.52)	80.9 (3.19)	125.7 (4.95)
MPAR-x3200E-M2A	703.8 (27.71)					
MPAR-x3300E-M2A	803.8 (31.65)					
MPAR-x3400E-M2A	903.8 (35.58)					
MPAR-x3600E-M2A	1103.8 (43.46)					
MPAR-x3800E-M2A	1303.8 (51.33)					
MPAR-x3100H-M2A	574.8 (22.63)	149.8 (5.90)	92.5 (3.64)	98.3 (3.87)	83.9 (3.30)	132.8 (5.23)
MPAR-x3200H-M2A	674.8 (26.57)					
MPAR-x3300H-M2A	774.8 (30.50)					
MPAR-x3400H-M2A	874.8 (34.44)					
MPAR-x3600H-M2A	1074.8 (42.31)					
MPAR-x3800H-M2A	1274.8 (50.19)					

- (1) If you are ordering an MPAR-x3xxxE-M4x actuator with brake, add 34.5 mm (1.36 in.) to dimensions L7 and LB.
If you are ordering an MPAR-x3xxxH-M4x actuator with brake, add 48.5 mm (1.91 in.) to dimensions L7 and LB.
- (2) If you are ordering an MPAR-x3xxxE-M4x actuator with brake, add 34.5 mm (1.36 in.) to dimension LE.
If you are ordering an MPAR-x3xxxH-M4x actuator with brake, add 48.5 mm (1.91 in.) to dimension LE.

MP-Series Electric Cylinder Dimensions (parallel, frame 63)

Electric Cylinder Cat. No.	L71 mm (in.)
MPAR-x3100x-M2B/D/E	428.0 (16.85)
MPAR-x3200x-M2B/D/E	528.0 (20.79)
MPAR-x3300x-M2B/D/E	628.0 (24.72)
MPAR-x3400x-M2B/D/E	728.0 (28.66)
MPAR-x3600x-M2B/D/E	928.0 (36.53)
MPAR-x3800x-M2B/D/E	1128.0 (44.41)

Connector Data

This table lists the signal descriptions for feedback, power, and brake connector pins on the electric cylinder.

Feedback		
Pin	Signal Name MPAR-Axxxxx (200V class)	Signal Name MPAR-Bxxxxx (400V class)
1	Sin+	Sin+
2	Sin-	Sin-
3	Cos+	Cos+
4	Cos-	Cos-
5	Data+	Data+
6	Data-	Data-
7	Reserved	Reserved
8		
9		
10	+5V DC	
10	Common	
11	Reserved	+9V DC
12		Common
13	TS+	TS+
14	TS-	TS-
15	Reserved	Reserved
16		
17		
Case	Shield	Shield

Power and Brake	
Pin	Signal Name
A	Phase U ⁽¹⁾
B	Phase V ⁽¹⁾
C	Phase W ⁽¹⁾
D	Ground ⁽¹⁾
E	Reserved ⁽¹⁾
F	MBRK+ ^{(1) (2)}
G	MBRK- ^{(1) (2)}
H	Reserved
L	
Case	Cable shield and GND

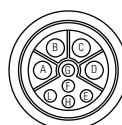

Intercontec P/N
BEDC090NN00000005000
Mating Cable Allen-Bradley
2090-XXNPMF-16S.xx

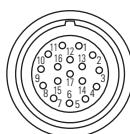

Intercontec P/N AEDC113NN00000012000
Mating Cable Allen-Bradley 2090-XXNFMF-S.xx

- (1) Power pins A, B, C, and D may be labelled as U, V, W, and GND respectively. Brake pins F and G may be labelled as + and - respectively. Reserved pins E and H may be numbered 1 or 2.
- (2) Brake+ and Brake- are available only on electric cylinders with a brake.



Be sure that cables are installed and restrained to prevent uneven tension or flexion at the cable connectors. Excessive and uneven force at the cable connector may result in damage to the housing and contacts as the cable flexes. Failure to observe these safety precautions can result in damage to the motor and its components.

Commissioning

This section provides guidelines for using RSLogix 5000 software to configure your electric-cylinder servo drive system.

Required Files

Firmware revisions and software versions required to support the electric cylinders include the following:

- RSLogix 5000 software, version 16.00 or later
- Kinetix 2000 or Kinetix 6000 multi-axis drives
 - Firmware revision 1.96 or later
 - For RSLogix 5000 software, version 16.xx
use Motion Database file, version 4_23_0 or later
 - For RSLogix 5000 software, version 17.xx or later
use Motion Database file, version 5_15_0 or later
- Ultra3000 drives
 - Firmware revision 1.52 or later
 - Motion Database (.mdb) file, dated April 2010 or later
- Motion Analyzer software, version 4.7 or later

Download these files from <http://www.rockwellautomation.com/support>. Contact Rockwell Automation Technical Support at (440) 646-5800 for assistance.

Configure Your Electric Cylinder

Configure the electric cylinder by using the basic parameter settings described in this section. Please use the procedure appropriate for your drive. There is a procedure for Kinetix 2000 and Kinetix 6000 drives and individual procedures for Kinetix 300 and Ultra3000 drives.



ATTENTION: Moving parts can cause injuries. Before running the electric cylinder, make sure all components are secure and safeguards are in place to prevent access to the path of moving machinery. Safeguards should prevent access to the electric cylinder until all motion has stopped. Check that the electric cylinder is clear of foreign matter and tools. Objects hit by the moving piston rod can become projectiles that can cause personal injury or damage to the equipment.

IMPORTANT It is your responsibility to verify that the servo control system safely controls the electric cylinder with regard to maximum force, acceleration, and speed.

Configure Your Electric Cylinder with RSLogix 5000 Software

Use the following procedure to configure the drive for your electric cylinder. It is assumed the electric cylinder and a Kinetix 2000 or Kinetix 6000 servo drive are installed and wired as one axis of a motion system.



ATTENTION: Incorrect parameter settings may result in uncontrolled motion with the potential for damage to the electric cylinder. Initiating a motion command on an electric cylinder with an incorrect Position mode setting may result in damage to the electric cylinder and the machine in which it is installed.

1. Enter these parameters in the Axis Properties tabs of RSLogix 5000 software for electric cylinder.

Axis Properties Tab	Parameter	Entry/Selection
Drive/Motor	Motor Catalog Number	Select one from the list MPAR-A1xxxB-V2x MPAR-B1xxxB-V2x MPAR-A1xxxB-V4x MPAR-B1xxxB-V4x MPAR-A1xxxE-V2x MPAR-B1xxxE-V2x MPAR-A1xxxE-V4x MPAR-B1xxxE-V4x MPAR-A2xxxC-V2x MPAR-B2xxxC-V2x MPAR-A2xxxC-V4x MPAR-B2xxxC-V4x MPAR-A2xxxF-V2x MPAR-B2xxxF-V2x MPAR-A2xxxF-V4x MPAR-B2xxxF-V4x MPAR-A3xxxE-M2x MPAR-B3xxxE-M2x MPAR-A3xxxE-M4x MPAR-B3xxxE-M4x MPAR-A3xxxH-M2x MPAR-B3xxxH-M2x MPAR-A3xxxH-M4x MPAR-B3xxxH-M4x
	Drive Resolution	200,000
	Drive Counts per	Motor Rev

Axis Properties Tab	Parameter	Entry/Selection (with applicable distance unit settings)	
		Metric	English
Conversion	Positioning Mode	Linear Setting the Positioning Mode to Rotary can cause damage to the electric cylinder or the machine due to incorrect positioning.	
	Conversion Constant	66666.667 drive cnts/1.0 mm for	1693333.3 drive cnts/1.0 in. for
		MPAR-x1xxxB-V2x MPAR-x1xxxB-V4x	
	Conversion Constant	20000 drive cnts/1.0 mm for	508000 drive cnts/1.0 in. for
		MPAR-x1xxxE-V2x MPAR-x1xxxE-V4x MPAR-x3xxxE-M2x MPAR-x3xxxE-M4x	
		40000 drive cnts/1.0 mm for	1016000 drive cnts/1.0 in. for
		MPAR-x2xxxC-V2x MPAR-x2xxxC-V4x	
	Conversion Constant	15748.0315 drive cnts/1.0 mm for	400000 drive cnts/1.0 in. for
		MPAR-x2xxxF-V2x MPAR-x2xxxF-V4x	
	Conversion Constant	10000 drive cnts/1.0 mm for	254000 drive cnts/1.0 in. for
MPAR-x3xxxH-M2x MPAR-x3xxxH-M4x			
Dynamics	Maximum Speed ⁽¹⁾	150 mm/s (default 157.5 mm/s)	5.91 in/s (default 6.20 in/s)
		MPAR-x1xxxB-xxx	
		500 mm/s (default 525 mm/s)	19.68 in/s (default 20.67 in/s)
		MPAR-x1xxxE-xxx	
		250 mm/s (default 262.5 mm/s)	9.82 in/s (default 10.33 in/s)
		MPAR-x2xxxC-xxx	
		640 mm/s (default 672 mm/s)	24.61 in/s (default 25.84 in/s)
		MPAR-x2xxxF-xxx	
		500 mm/s (default 525 mm/s)	19.68 in/s (default 20.67 in/s)
		MPAR-x3xxxE-xxx	
		1000 mm/s (default 1050 mm/s)	41.34 in/s (default 43.41 in/s)
		MPAR.x3xxxH-xxx	
	Maximum Acceleration ⁽²⁾	6000 mm/s/s	236.22 in/s/s
	Maximum Deceleration ⁽²⁾	6000 mm/s/s	236.22 in/s/s
Maximum Acceleration Jerk	Use default values, or adjusted for your application.		
Maximum Deceleration Jerk	Use default values, or adjusted for your application.		

(1) The default value is 5% more than your actuator-rated maximum speed. Do not command maximum speed in your application in excess of the rated speed.
 (2) Accelerations in excess of these values may lead to reduction of life of your actuator.

2. Click the Homing tab.
3. Set parameters for either absolute homing or torque level-to-marker homing as shown on the table.

Parameter	Absolute Homing Value	Torque Level-to-marker Homing Value
Mode	Absolute	Active
Position	0, typical	0, typical
Offset	N/A	0 mm
Sequence	Immediate	Torque level-to-marker
Direction	N/A	Reverse bidirectional
Torque Level	N/A	30%, min Greater if the system friction, force, or weight exceeds 30% of the Continuous Force Rating at any point in the range of motion
Speed	N/A	10 mm/s (1.97 in/s)
Return Speed	N/A	10 mm/s (0.39 in/s)



ATTENTION: Avoid excessive force while homing the electric cylinder. Do not exceed 10 mm/s (0.4 in/s) during a home routine. Speeds greater than 10 mm/s (0.4 in/s) may damage the electric cylinder when the piston rod reaches the end of travel.

4. Complete the following steps for absolute homing.
 - a. Use motion direct commands to slowly jog your axis to your application's home location. Do not exceed 10 mm/s (0.4 in/s).
 - b. Issue the Motion Direct Command (MAH) to set the home position on your axis.
5. Click the Limits tab.
6. Enter these parameters.

Parameter	Entry/Selection (with applicable distance unit settings)
Hard Travel Limits	Check if hardware limits are in use. Use the Motion Analyzer software to determine the maximum stopping distance in your application to set negative and positive limits.
Soft Travel Limits	Check if software limits are in use. Use the Motion Analyzer software to determine the maximum stopping distance in your application to set negative and positive limits.
Maximum Positive	Enter value that is within the piston-rod mechanical travel.
Maximum Negative	Enter value that is within the piston-rod mechanical travel.

- Set overtravel limits according to the maximum speed of the servo drive system and the payload of the application.

IMPORTANT Set travel limits and direction of tuning moves in reference to piston-rod starting position. Leave adequate travel for the piston rod to complete its moves while tuning.



ATTENTION: Software overtravel must be set prior to initiating tuning process. Check the starting position of the piston rod and allow for adequate travel. Insufficient travel while auto tuning will trigger the software overtravel or cause an end-stop impact.

You can determine the deceleration distance before the piston rod contacts the end of travel based on the deceleration rate of the load, and the available peak force from the motor/ballscrew combination. Use the [Motion Analyzer](#) software to calculate the minimum deceleration distance at the maximum speed of your application.

IMPORTANT Do not exceed the maximum energy specified for end-of-travel impacts.

Cat. No.	Impact Energy, max
MPAR-x1xxx-xxx	0.0001 J
MPAR-x2xxx-xxx	0.0002 J
MPAR-x3xxx-xxx	0.0004 J

This table lists maximum velocity for end-stop impact with no load.

Cat. No.	Extended Mass g (oz)	Impact Velocity, max mm/s (in/s)
MPAR-x1100B-xxx	239 (8.4)	28.9 (1.14)
MPAR-x1200B-xxx	308 (10.8)	25.5 (1.00)
MPAR-x1300B-xxx	377 (13.9)	23.0 (0.91)
MPAR-x1400B-xxx	446 (15.7)	21.2 (0.83)
MPAR-x1100E-xxx	269 (9.5)	27.3 (1.07)
MPAR-x1200E-xxx	338 (11.9)	24.3 (0.96)
MPAR-x1300E-xxx	407 (14.36)	22.2 (0.87)
MPAR-x1400E-xxx	476 (16.8)	20.5 (0.81)
MPAR-x2100C-xxx	399 (14.1)	31.7 (1.25)
MPAR-x2200C-xxx	488 (17.2)	28.6 (1.12)
MPAR-x2300C-xxx	577 (20.4)	26.3 (1.03)

Cat. No.	Extended Mass g (oz)	Impact Velocity, max mm/s (in/s)
MPAR-x2400C-xxx	666 (23.5)	24.5 (0.96)
MPAR-x2600C-xxx	844 (29.8)	21.8 (0.86)
MPAR-x2100F-xxx	469 (16.5)	29.2 (1.15)
MPAR-x2200F-xxx	558 (19.7)	26.8 (1.05)
MPAR-x2300F-xxx	647 (22.82)	24.9 (0.98)
MPAR-x2400F-xxx	736 (26.0)	23.3 (0.92)
MPAR-x2600F-xxx	914 (32.2)	20.9 (0.82)
MPAR-x3100E-xxx	938 (33.1)	29.2 (1.15)
MPAR-x3200E-xxx	1066 (37.6)	27.4 (1.08)
MPAR-x3300E-xxx	1194 (42.1)	25.9 (1.02)
MPAR-x3400E-xxx	1322 (46.6)	24.6 (0.97)
MPAR-x3600E-xxx	1578 (55.7)	22.5 (0.86)
MPAR-x3800E-xxx	1834 (64.7)	20.9 (0.82)
MPAR-x3100H-xxx	938 (33.1)	29.2 (1.149)
MPAR-x3200H-xxx	1066 (37.6)	27.4 (1.08)
MPAR-x3300H-xxx	1194 (42.1)	25.9 (1.02)
MPAR-x3400H-xxx	1322 (46.6)	24.6 (0.97)
MPAR-x3600H-xxx	1578 (55.7)	22.5 (0.88)
MPAR-x3800H-xxx	1834 (64.7)	20.9 (0.82)

IMPORTANT Absolute position is maintained while the motor feedback cable is connected to the drive. If the cable is disconnected or if a motor fault is reported by the drive, the absolute home position must be reestablished.

Tune Your Electric Cylinder with RSLogix 5000 Software

This section shows the steps to tune electric cylinders with RSLogix 5000 software, version 16.

- Tuning your electric cylinder requires you to calculate and configure the loop gain based on the actual measured inertia.
- By setting travel limits, your application minimum deceleration is defined.

Follow these steps to tune your electric cylinder.

1. In the Axis Properties dialog box, click the Fault Actions tab.

- Click Set Custom Stop Action.

TIP These parameter settings work best if the electric cylinder is installed in a horizontal (table top) or a wall mount (vertical) orientation.

- In the Custom Stop Action Attributes dialog box, set the Brake Engage and the Brake Release delay times to the values listed in [Specifications](#) on [page 39](#).
- Reduce the default Stopping Time Limit from 10 seconds to 0.5 seconds.

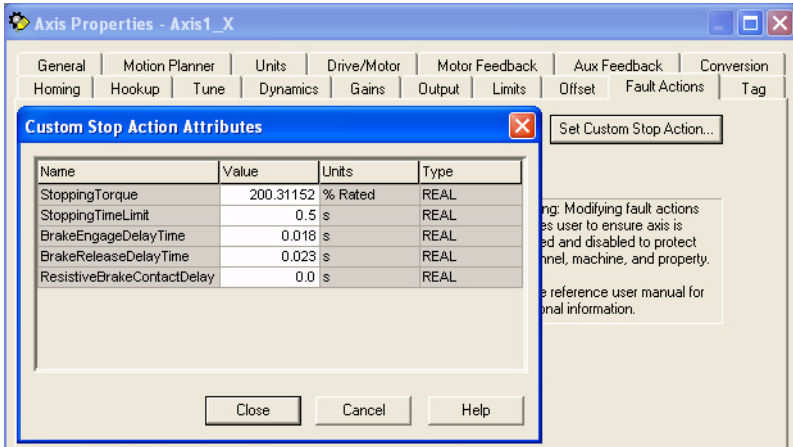

IMPORTANT To prevent the rod from moving or falling when installed in a vertical orientation, the Stopping Time Limit must be set to 0.99 seconds or less.

- Click the Tune tab and enter the following parameters:
 - Travel Limit - Set to within software limits.
 - Speed (velocity).
 - Torque/Force.

IMPORTANT Set travel limits and direction of tuning moves in reference to piston-rod starting position. Leave adequate travel for the piston rod to complete its moves while tuning.



ATTENTION: Software overtravel must be set prior to initiating tuning process. Check the piston-rod starting position and allow for adequate travel. Insufficient travel while auto tuning will trigger the software overtravel or cause an end-stop impact.

IMPORTANT Check Torque Offset, as shown below, only if the electric cylinder is installed in a non-horizontal mount position.

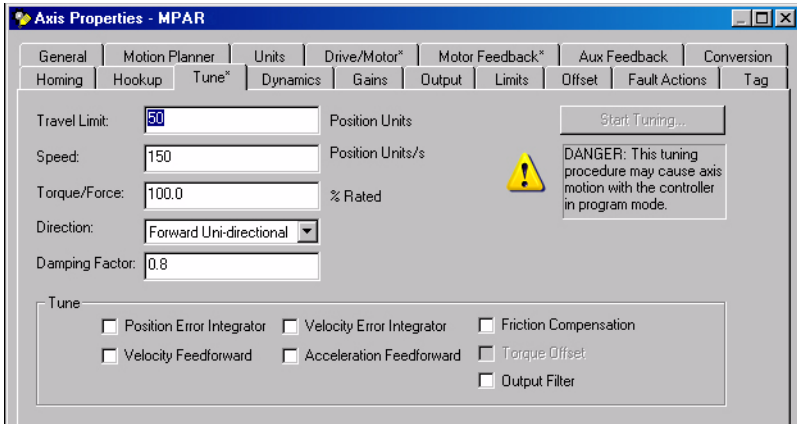

- Click Start Tuning to access the Motion Initiation dialog box.
- Click Yes to begin tuning the electric cylinder.

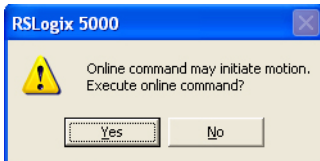

ATTENTION: Motion occurs immediately after clicking Yes.

Tuning is complete when the Tune Servo dialog box opens.

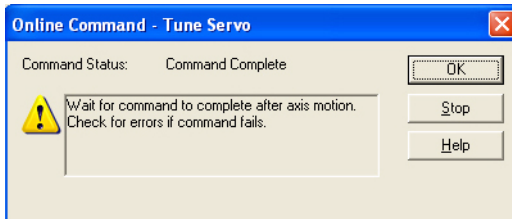

- Click OK to exit Tuning.

The Tune Results dialog box opens.

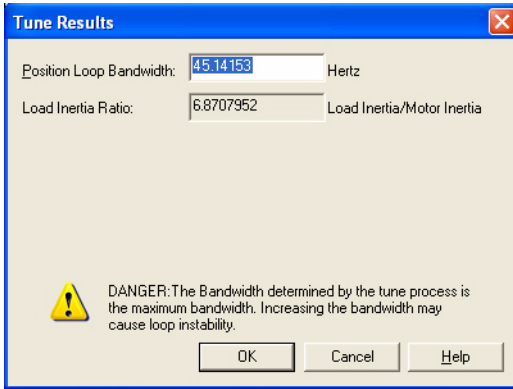

- If you are satisfied with the tuning results, click OK: otherwise continue with [Calculate and Configure the Loop Gain](#).

Calculate and Configure the Loop Gain

Calculate a position loop bandwidth based on the actual measured inertia values from the Tune Results dialog box.

In this example, the Tune Results dialog box shows a default Position Loop Bandwidth of 45.14153 Hz and a Load Inertia Ratio of 6.8707952.

- Calculate the Corrected Position Bandwidth.

Corrected Position Loop Bandwidth = (Initial Position Loop Bandwidth Result / (Initial Load Inertia Ratio Result + 1))

For example, $5.73532 = 45.14153 / 7.8707952$

- Enter the Corrected Position Bandwidth value 5.73532 as the Position Loop Bandwidth.

- Click OK.

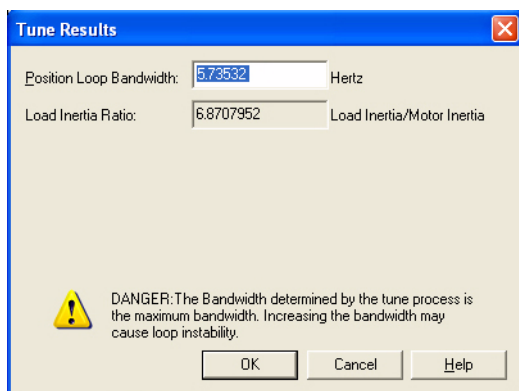

- Answer the remaining dialog boxes to apply the values.

The proper Position Bandwidth results in a stable starting point from which you can adjust the gains to fit your application requirements.

Configure Your Electric Cylinders with Ultraware Software

These steps assume that an electric cylinder and Ultra3000 drive are installed and wired as one axis of a motion system.

For help using Ultraware software as it applies to setting up your electric cylinder, refer to [Additional Resources](#) on [page 44](#). This procedure assumes that you are familiar with Ultraware software.

- Connect a serial cable, catalog number 2090-DAPC-D09xx, to the CN3 connector on your Ultra3000 drive.
- Apply AC input power to the Ultra3000 drive.

When communication with the Ultra3000 drive is established, the Ultra3000 motor database dialog box opens.

- Click Cancel.

Ultraware software begins scanning for online drives. When a drive is found, an Online Drive icon opens in the Workspace.

- Double-click the Online Drive icon to view the main Drive set-up dialog box.
- Verify that the data in the Model Field is correct for your electric cylinder.
- From the Displayed Units pull-down menu, choose User.

This programs Ultraware software to make distance moves in User Units (mm or in.).

7. Expand the Motor Encoder Units menu and enter the appropriate values from the table. The Kinetix 300 drive default user units are in motor revolutions. The table converts the displayed User Units into units used for linear motion, either millimeters or inches. Accelerations in excess of 6000 mm/s/s (236.2 in/s/s) may shorten life of your actuator. Use the values in the table to limit the acceleration and deceleration of your actuators to 6000 mm/s/s (236.2 in/s/s).

Cat. No.	Screw mm/rev (in./rev)	Encoder periods/rev	Velocity Scale mm/s (in/s)	Position Scale mm (in.)	Acceleration Scale mm/s/s (in/s/s)
MPAR-x1xxxB	3.0 (0.12)	128	43690.67 (1109742.93)	43960.67 (1116601.02)	43960.67 (1116601.02)
MPAR-x1xxxE	10.0 (0.39)	128	13107.20 (332922.88)	13107.20 (332922.88)	13107.20 (332922.88)
MPAR-x2xxxC	5.0 (0.20)	128	26214.40 (665845.76)	26214.40 (665845.76)	26214.40 (665845.76)
MPAR-x2xxxF	12.7 (0.50)	128	10320.63 (262144.00)	10320.63 (262144.00)	10320.63 (262144.00)
MPAR-x3xxxE	10.0 (0.39)	1024	104857.60 (2663383.04)	104857.60 (2663383.04)	104857.60 (2663383.04)
MPAR-x3xxxH	20.0 (0.79)	1024	52428.80 (1331691.52)	52428.80 (1331691.52)	52428.80 (1331691.52)

Configure Kinetix 300 Drive for Electric Cylinders

These steps assume that an electric cylinder and the Kinetix 300 drive are installed and wired as one axis of a motion system.

For help using the Kinetix 300 drive as it applies to setting up your electric cylinder, refer to [Additional Resources](#) on [page 44](#). This procedure assumes that you are familiar with the Kinetix 300 drive.

1. Run MotionView Onboard software.
2. From the Drive Organizer, click Motor.
3. Verify that your electric cylinder model is displayed in the Motor Model field.
4. Click Change Motor.
5. Click Ok.
6. From the Drive Organizer, click General.

7. Using values from the following table, enter Accel Limit, Decel Limit, and User Units. User Units can be entered in rev/mm or rev/in. Your choice determines the unit of measure for the axis.

Cat. No.	Accel/Decel Limits rpm/s	User Units rev/mm (rev/in.)
MPAR-x1xxxB-Vxx	120000	0.33333 (8.46667)
MPAR-x1xxxE-Vxx	36000	0.10000 (2.54000)
MPAR-x2xxxC-Vxx	72000	0.20000 (5.08000)
MPAR-x2xxxF-Vxx	28346	0.07874 (2.00000)
MPAR-x3xxxE-Mxx	36000	0.10000 (2.54000)
MPAR-x3xxxH-Mxx	18000	0.05000 (1.27000)

8. From the Drive Organizer, click Homing.

9. Enter values from the following table.

These values are recommended; your application may require different values.

Parameter	Metric	English
Home Accel/Decel	10.0000 mm/s ²	0.3937 in/s ²
Home Offset	0.0000 mm	0.0000 in.
Home Velocity Fast	10.0000 mm/s	0.3937 in/s
Home Velocity Slow	10.0000 mm/s	0.3937 in/s
Home Switch	Input B1	

10. Select recommend homing method ID = 33, Home to marker, Reverse.

Description	Value	Units	Min
Home Accel / Decel	<input type="text" value="10.0000"/>	User Units / Sec ²	0.0000
Home Offset	<input type="text" value="0.0000"/>	User Units	-104038.5083501
Home Velocity Fast	<input type="text" value="10.0000"/>	User Units / Sec	0.0000
Home Velocity Slow	<input type="text" value="10.0000"/>	User Units / Sec	0.0000
Home Switch	<input type="text" value="Input B1"/>		

Homing Status: Homed

ID	Home Method	Direction	Logix Type	Home Sensor Polarity
33	Marker	Reverse	Home to marker	n/a
25	Switch - Slow	Forward	Home to sensor	Inactive/Falling
27	Switch - Slow	Reverse	Home to sensor	Inactive/Falling
29	Switch - Fast	Reverse	Home to sensor	Active/Rising
33	Marker	Reverse	Home to marker	n/a
34	Marker	Forward	Home to marker	n/a
35	Immediate	n/a	n/a	n/a

Maintenance

Follow these steps to maintain your electric cylinder.

1. Remove power to the electric cylinder and lock-out tag-out power source.
2. Check the axial play of the piston rod for wear of the spindle nut.

Wear on the electric cylinder leads to increased noise.



ATTENTION: If a worn spindle nut breaks on a vertically or diagonally-mounted electric cylinder, the workload will fall. Uncontrolled moving mass can cause personal injury or damage to equipment.

3. Clean the electric cylinder with a soft cloth, if necessary, using any non-abrasive cleaning solution.
4. Lightly dampen a soft cloth with isopropyl alcohol and wipe the piston rod and seal.
5. Lubricate the piston rod with a fine layer of LUB-KC1 grease from Klueber at <http://www.klueber.com/>.

Storage

Store your electric cylinder for a minimal amount of time in a clean and dry location within Specifications on [page 39](#).

Troubleshooting

Description	Possible Cause	Corrective Action
Axial play too large.	Wear.	Replace actuator cylinder. Send to Rockwell Automation for repair.
Squeaking noises or vibrations.	Distortions.	Check the electric cylinder is free of stress and evenly supported ≤ 0.2 mm (0.008 in.). Lubricate piston rod. See Maintenance on page 32 . Modify positioning speed.
	Needs tuning.	Modify control parameters.
	Running noises of the spindle support (with strokes 300 mm (11.81 in.) and high positioning speeds).	Normal, no impairment of function.
Piston rod does not move.	Jamming in mechanical end position, after traveling at excessive speed or into end position.	Loosen jamming manually. <ol style="list-style-type: none"> 1. Switch off power supply. 2. Remove motor and coupling housing. 3. Turn drive shaft. Reduce speed for reference travel. Provide software end positions, at least 0.25 mm (0.01 in.) from the mechanical end positions (stops).
	Load is too large.	Reduce load mass. Reduce positioning speed. Return for repairs.
	Ambient temperature too low (increased breakaway torque in initial run due to increasing viscosity of the lubricants in the spindle system).	Reduce load mass. Reduce positioning speed. If necessary, allow higher current with servo motors (see operating instructions for the motor). Increase ambient temperature.

Description	Possible Cause	Corrective Action
No response from electric cylinder.	Controller/drive not enable.	Enable controller/drive.
	Controller/drive faulted.	Reset the controller/drive.
	Improper/failed wiring.	Check the wiring.
Electric cylinder is enabled but not operating or is operating erratically.	Feedback cable may be damaged.	Test the feedback cable.
	Feedback wiring may be incorrect.	Verify correct feedback wiring.
Electric cylinder is operating but is not up to rated speeds/forces.	Motor phase are wired incorrectly or in incorrect order.	Verify correct motor power wiring.
	Amplifier may be improperly tuned.	Check gain settings.
	Amplifier may be set up improperly for electric cylinder used.	Check amplifier setting for number of poles, voltage, current, resistance, inductance, inertia, and other motor settings.
Actuator cannot move load.	Force is too large for the capacity of the electric cylinder or too much friction is present.	Verify force requirements.
	Misalignment of piston rod to load.	Verify load alignment.
	Amplifier has too low current capacity or is limited to too low of current capacity.	Verify correct amplifier and settings.
Electric cylinder moves or vibrates when piston rod is in motion.	Loose mounting.	Check actuator mounting.
	Amplifier is improperly tuned-wrong gain setting.	Tune amplifier.
Actuator is overheating.	Duty cycle is higher than actuator rating.	Verify load forces and electric cylinder rating.
	Actuator is being operated outside of continuous rating.	Adjust operation to be within continuous operation rating.
	Amplifier is poorly tuned, causing excessive current to be applied to motor.	Check gain settings.

Accessories

The following diagram and tables show the available accessories and their weights. Refer to the Kinetic Motion Control Selection Guide, publication [GMC-SG001](#), for dimensions.

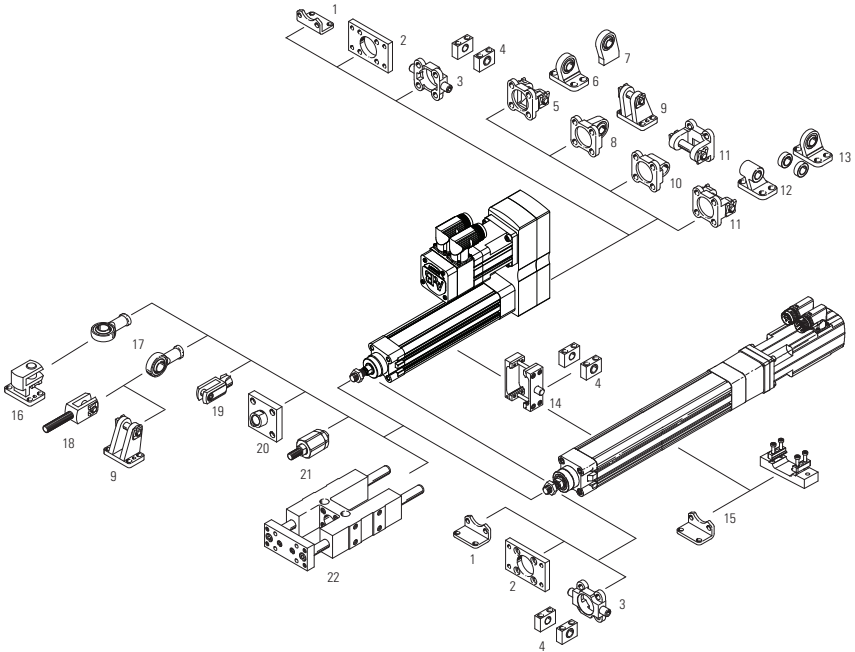

Accessory Item	Frame	Cat. No.	Weight, approx. g (oz)
1	Foot mount attachment	32	MPAR-NP174369 140 (4.94)
		40	MPAR-NP174370 280 (9.87)
		63	MPAR-NP174372 550 (19.40)
2	Flange mounting	32	MPAR-NA174376 240 (8.46)
		40	MPAR-NA174377 280 (9.88)
		63	MPAR-NA174379 690 (24.34)
3	Trunnion flange	32	MPAR-NA174411 130 (4.58)
		40	MPAR-NA174412 240 (8.46)
		63	MPAR-NA174414 600 (21.16)

Accessory Item	Frame	Cat. No.	Weight, approx. g (oz)
1	Foot mount attachment (corrosion resistant)	32	MPAR-NP176937 140 (4.94)
		40	MPAR-NP176938 280 (9.87)
		63	MPAR-NP176940 550 (19.40)
2	Flange mounting (corrosion resistant)	32	MPAR-NA161846 240 (8.46)
		40	MPAR-NA161847 300 (10.58)
		63	MPAR-NA161849 710 (25.04)
3	Trunnion flange (corrosion resistant)	32	MPAR-NA161852 150 (5.29)
		40	MPAR-NA161853 260 (9.17)
		63	MPAR-NA161855 640 (22.57)

Accessory Item		Frame	Cat. No.	Weight, approx. g (oz)	Accessory Item		Frame	Cat. No.	Weight, approx. g (oz)
4	Trunnion support	32	MPAR-NA32959	130 (4.58)	4	Trunnion support (corrosion resistant)	32	MPAR-NA161874	200 (7.05)
		40	MPAR-NA32960	400 (14.11)			40	MPAR-NA161875	330 (11.64)
		63	MPAR-NA32961	480 (16.93)			63	MPAR-NA161876	440 (11.64)
5	Swivel flange (pin, narrow)	32	MPAR-NP174383	90 (3.17)	6	Clevis foot (spherical bearing)	32	MPAR-NP31740	185 (6.53)
		40	MPAR-NP174384	120 (4.23)			40	MPAR-NP31741	295 (10.40)
		63	MPAR-NP174386	320 (11.29)			63	MPAR-NP31743	655 (23.10)
7	Clevis foot (weld-on)	32	MPAR-NP31747	105 (3.70)	8	Swivel flange (spherical bearing)	32	MPAR-NP174397	85 (3.00)
		40	MPAR-NP31748	160 (5.64)			40	MPAR-NP174398	125 (4.41)
		63	MPAR-NP31747	365 (12.87)			63	MPAR-NP174400	280 (9.88)
9	Clevis foot (pin)	32	MPAR-NA31761	220 (7.76)	10	Swivel flange	32	MPAR-NP174404	75 (2.64)
		40	MPAR-NA31762	300 (10.58)			40	MPAR-NP174405	100 (3.53)
		63	MPAR-NA31764	580 (20.46)			63	MPAR-NP174407	250 (8.82)
11	Swivel flange (pin, wide)	32	MPAR-NP174390	100 (3.53)	11	Swivel flange (corrosion resistant)	32	MPAR-NP176944	100 (3.53)
		40	MPAR-NP174391	150 (5.29)			40	MPAR-NP176945	150 (5.29)
		63	MPAR-NP174393	370 (13.05)			63	MPAR-NP176947	370 (13.05)
12	Clevis foot	32	MPAR-NP33890	170 (6.00)	12	Clevis foot (corrosion resistant)	32	MPAR-NP161840	120 (4.23)
		40	MPAR-NP33891	240 (8.46)			40	MPAR-NP161841	210 (7.41)
		63	MPAR-NP33893	520 (18.34)			63	MPAR-NP161843	450 (15.87)
13	Clevis foot (spherical bearing)	32	MPAR-NP5561	160 (5.64)	14	Trunnion mounting kit	32	MPAR-NA163525	210 (7.41)
		40	MPAR-NP5562	270 (9.52)			40	MPAR-NA163526	390 (13.76)
		63	MPAR-NP5564	605 (21.34)			63	MPAR-NA163528	890 (31.39)
15	Foot mounting kit	32	MPAR-NA174991	240 (8.46)	16	Clevis foot (right angle)	32	MPAR-NA31768	290 (10.23)
		40	MPAR-NA174992	310 (10.93)			40	MPAR-NA31769	360 (12.70)
		63	MPAR-NA174993	510 (17.99)			63	MPAR-NA31771	880 (31.0)

MP-Series Electric Cylinders Rod-end Accessories

MP-Series Electric Cylinders Rod-end Accessories				MP-Series Electric Cylinders Rod-end Accessories					
Accessory Item	Frame	Cat. No.	Weight, approx. g (oz)	Accessory Item	Frame	Cat. No.	Weight, approx. g (oz)		
17	Rod eye	32	MPAR-NE9261	70 (2.47)	17	Rod eye (corrosion resistant)	32	MPAR-NE195582	70 (2.47)
		40	MPAR-NE9262	110 (3.53)			40	MPAR-NE195583	110 (3.53)
		63	MPAR-NE9263	210 (7.41)			63	MPAR-NE195584	210 (7.41)
18	Rod clevis (threaded rod)	32	MPAR-NE32954	140 (4.94)	19	Rod clevis	32	MPAR-NE6144	110 (3.88)
		40	MPAR-NE10767	210 (7.41)			40	MPAR-NE6145	170 (6.00)
		63	MPAR-NE10768	500 (17.64)			63	MPAR-NE6146	390 (13.76)
19	Rod clevis (corrosion resistant)	32	MPAR-NE13569	110 (3.88)	20	Coupling piece	32	MPAR-NE36125	110 (3.88)
		40	MPAR-NE13570	180 (6.35)			40	MPAR-NE36126	180 (6.35)
		63	MPAR-NE13571	400 (14.11)			63	MPAR-NE36127	250 (8.82)
21	Self-aligning rod coupler	32	MPAR-NE6140	210 (7.41)					
		40	MPAR-NE6141	220 (7.76)					
		63	MPAR-NE6142	650 (22.93)					

MP-Series and TL-Series Electric Cylinders Rod Guide (item 22) Accessories

Rod Guide Cat. No.	Frame	Stroke Length mm (in.)	Weight, approx. kg (lb)
MPAR-NE34494	32	100 (3.9)	1.7 (3.75)
MPAR-NE34496		200 (7.9)	1.9 (4.19)
MPAR-NE34497		320 (12.6)	2.1 (4.63)
MPAR-NE150290		400 (15.7)	2.3 (5.07)
MPAR-NE34500	40	100 (3.9)	2.7 (5.95)
MPAR-NE34502		200 (7.9)	3.0 (6.61)
MPAR-NE34504		320 (12.6)	3.4 (7.50)
MPAR-NE150291		400 (15.7)	3.7 (8.16)
MPAR-NE34505		500 (19.7)	4.0 (8.82)
MPAR-NE34514	63	100 (3.9)	5.9 (13.01)
MPAR-NE34516		200 (7.9)	6.4 (14.11)
MPAR-NE34518		320 (12.6)	7.0 (15.43)
MPAR-NE34519		400 (15.7)	7.4 (16.31)
MPAR-NE34520		500 (19.7)	7.9 (17.42)

Trunnion Mounting Kit

Cat. No.	Frame Size	Torque N•m (lb•ft)
MPAR-NA163525	32	4...5 (2.9...3.7)
MPAR-NA163526	40	8...9 (5.9...6.6)
MPAR-NA163528	63	18...20 (13.3...14.5)

Coupling Piece Attachment

Cat. No.	Frame Size	Max Torque ⁽¹⁾ N•m (lb•ft)	Max Torque ⁽²⁾ N•m (lb•ft)	Max Torque ⁽³⁾ N•m (lb•ft)
MPAR-NE36125	32	5.9 (4.35)	34 (25.1)	12 (8.8)
MPAR-NE36126	40	5.9 (4.35)	61 (45.0)	22 (16.2)
MPAR-NE36127	63	9.9 (7.3)	148 (109.2)	57 (42.0)

- (1) Torque applies to mounting screws with standard threads and strength class 8.8. Apply torque evenly to mounting screws.
- (2) Torque applies to lock nut on piston rod.
- (3) Torque that the coupling can transmit with coefficient of friction $\mu = 0.1$ and 10 x safety margin at maximum permissible tightening torque.

Actuator Cylinders (weight of replacement cylinder)

Actuator Cylinder ⁽¹⁾ Cat. No.	Weight, approx. kg (lb)	Actuator Cylinder ⁽¹⁾ Cat. No.	Weight, approx. kg (lb)	Actuator Cylinder ⁽¹⁾ Cat. No.	Weight, approx. kg (lb)
MPAR-X1100B	1.1 (2.43)	MPAR-X2100C	1.7 (3.75)	MPAR-X3100E	3.8 (8.38)
MPAR-X1200B	1.4 (3.09)	MPAR-X2200C	2.2 (4.85)	MPAR-X3200E	4.6 (10.14)
MPAR-X1300B	1.7 (3.75)	MPAR-X2300C	2.6 (5.73)	MPAR-X3300E	5.4 (11.90)
MPAR-X1400B	2.1 (4.63)	MPAR-X2400C	3.1 (6.83)	MPAR-X3400E	6.3 (13.89)
MPAR-X1100E	1.1 (4.63)	MPAR-X2600C	4.0 (8.82)	MPAR-X3600E	7.9 (17.46)
MPAR-X1200E	1.4 (3.09)	MPAR-X2100F	1.8 (3.97)	MPAR-X3800E	9.5 (20.94)
MPAR-X1300E	1.8 (3.97)	MPAR-X2200F	2.3 (5.07)	MPAR-X3100H	3.8 (8.38)
MPAR-X1400E	2.1 (4.63)	MPAR-X2300F	2.8 (6.17)	MPAR-X3200H	4.6 (10.14)
		MPAR-X2400F	3.2 (7.05)	MPAR-X3300H	5.4 (11.90)
		MPAR-X2600F	4.2 (9.26)	MPAR-X3400H	6.3 (13.89)
				MPAR-X3600H	7.9 (17.42)
				MPAR-X3800H	9.5 (20.94)

- (1) Replacement actuator cylinder example, if ordering a replacement cylinder for electric cylinder catalog numbers MPAR-A2100C-V2A the replacement actuator cylinder is catalog number MPAR-X2100C.

See MP-Series and TL-Series Replacement Parts Installation Instructions, publication [MPAR-IN002](#), for procedures to replace electric cylinder parts and to obtain other replacement part catalog numbers.

Specifications

Brake Specifications

Electric Cylinder Cat. No.	Holding Force N (lb)	Coil Current at 24V DC A	Brake Response Time		
			Release ⁽¹⁾ ms	Engage (using external arc-suppression device)	
				MOV ⁽²⁾ ms	Diode ⁽³⁾ ms
MPAR-A/B1xxxB	300 (67)	0.43...0.53	23	9	18
MPAR-A/B1xxxE	350 (79)				
MPAR-A/B2xxxC	525 (118)				
MPAR-A/B2xxxF	800 (180)	0.46...0.56	58	20	42
MPAR-A/B3xxxE	2364 (531)	0.45...0.55	50	20	110
MPAR-A/B3xxxH	1625 (365)	0.576...0.704	110	25	160

(1) Brake release time delay with voltage applied.

(2) Brake engage time delay with voltage removed and MOV used for arc suppression.

(3) Brake engage time delay with voltage removed and diode used for arc suppression.

Environmental Specifications

Attribute	Value
Ambient temperature	0...40 °C (32...104 °F)
Storage temperature	-25...60 °C (-13...140 °F)
Relative humidity (noncondensing)	5...95%
Shock	20 g peak, 6 ms duration
Vibration	2.5 g peak @ 30...2000 Hz

Electric Cylinders (weight of cylinder with non-brake motor)

Electric Cylinder Cat. No.	Weight, approx. (1) kg (lb)	Electric Cylinder Cat. No.	Weight, approx. kg (lb)	Electric Cylinder Cat. No.	Weight, approx. kg (lb)
MPAR-x1100B-V2A	2.6 (5.73)	MPAR-x2100C-V2A	3.7 (8.16) ⁽¹⁾	MPAR-x3100E-M2A	9.5 (20.94) ⁽³⁾
MPAR-x1100B-V2B/D/E	3.5 (7.72)	MPAR-x2100C-V2B/D/E	4.4 (9.70) ⁽¹⁾	MPAR-x3100E-M2B/D/E	13.6 (29.98) ⁽³⁾
MPAR-x1200B-V2A	2.9 (6.39)	MPAR-x2200C-V2A	4.1 (9.04) ⁽¹⁾	MPAR-x3200E-M2A	10.3 (22.71) ⁽³⁾
MPAR-x1200B-V2B/D/E	3.8 (8.377)	MPAR-x2200C-V2B/D/E	4.9 (10.80) ⁽¹⁾	MPAR-x3200E-M2B/D/E	14.4 (31.75) ⁽³⁾
MPAR-x1300B-V2A	3.2 (7.05)	MPAR-x2300C-V2A	4.6 (10.14) ⁽¹⁾	MPAR-x3300E-M2A	11.1 (24.47) ⁽³⁾
MPAR-x1300B-V2B/D/E	4.1 (9.04)	MPAR-x2300C-V2B/D/E	5.3 (11.68) ⁽¹⁾	MPAR-x3300E-M2B/D/E	15.2 (33.51) ⁽³⁾
MPAR-x1400B-V2A	3.5 (7.72)	MPAR-x2400C-V2A	5.0 (11.02) ⁽¹⁾	MPAR-x3400E-M2A	11.9 (26.23) ⁽³⁾
MPAR-x1400B-V2B/D/E	4.5 (9.92)	MPAR-x2400C-V2B/D/E	5.8 (12.79) ⁽¹⁾	MPAR-x3400E-M2B/D/E	16.1 (35.49) ⁽³⁾
MPAR-x1100E-V2A	3.0 (6.61)	MPAR-x2600C-V2A	6.0 (11.02) ⁽¹⁾	MPAR-x3600E-M2A	13.5 (29.76) ⁽³⁾
MPAR-x1100E-V2B/D/E	3.8 (8.377)	MPAR-x2600C-V2B/D/E	6.7 (14.77) ⁽¹⁾	MPAR-x3600E-M2B/D/E	17.7 (39.02) ⁽³⁾
MPAR-x1200E-V2A	3.3 (7.27)	MPAR-x2100F-V2A	4.2 (9.26) ⁽²⁾	MPAR-x3800E-M2A	15.2 (33.51) ⁽³⁾
MPAR-x1200E-V2B/D/E	4.1 (9.04)	MPAR-x2100F-V2B/D/E	6.5 (14.33) ⁽²⁾	MPAR-x3800E-M2B/D/E	19.3 (42.55) ⁽³⁾
MPAR-x1300E-V2A	3.6 (7.94)	MPAR-x2200F-V2A	4.7 (10.36) ⁽²⁾	MPAR-x3100H-M2A	9.3 (20.50) ⁽⁴⁾
MPAR-x1300E-V2B/D/E	4.5 (9.92)	MPAR-x2200F-V2B/D/E	7.0 (15.43) ⁽²⁾	MPAR-x3100H-M2B/D/E	13.2 (29.10) ⁽⁴⁾
MPAR-x1400E-V2A	4.0 (8.82)	MPAR-x2300F-V2A	5.2 (11.46) ⁽²⁾	MPAR-x3200H-M2A	10.1 (22.27) ⁽⁴⁾
MPAR-x1400E-V2B/D/E	4.8 (10.58)	MPAR-x2300F-V2B/D/E	7.5 (16.53) ⁽²⁾	MPAR-x3200H-M2B/D/E	14.0 (30.86) ⁽⁴⁾
		MPAR-x2400F-V2A	5.6 (12.34) ⁽²⁾	MPAR-x3300H-M2A	10.9 (24.03) ⁽⁴⁾
		MPAR-x2400F-V2B/D/E	7.9 (17.42) ⁽²⁾	MPAR-x3300H-M2B/D/E	14.8 (32.63) ⁽⁴⁾
		MPAR-x2600F-V2A	6.6 (14.55) ⁽²⁾	MPAR-x3400H-M2A	11.7 (25.79) ⁽⁴⁾
		MPAR-x2600F-V2B/D/E	8.9 (19.62) ⁽²⁾	MPAR-x3400H-M2B/D/E	15.7 (34.61) ⁽⁴⁾
				MPAR-x3600H-M2A	13.4 (29.54) ⁽⁴⁾
				MPAR-x3600H-M2B/D/E	17.3 (38.14) ⁽⁴⁾
				MPAR-x3800H-M2A	15.0 (33.07) ⁽⁴⁾
				MPAR-x3800H-M2B/D/E	18.9 (41.67) ⁽⁴⁾

- (1) If you are ordering an MPAR-x1xxxx-V4x or MPAR-x2xxxC-V4x electric cylinder with brake, add 0.2 kg (0.4 lb).
- (2) If you are ordering an MPAR-x2xxxF-V4x electric cylinder with brake, add 0.4 kg (0.9 lb).
- (3) If you are ordering an MPAR-x3xxxE-V4x electric cylinder with brake, add 1.0 kg (2.2 lb)
- (4) If you are ordering an MPAR-x3xxxH-M4x electric cylinder with brake, add 1.7 kg (3.7 lb).

Interconnect Diagrams

These are example diagrams for wiring your MP-Series electric cylinder and Allen-Bradley servo drives.

Wiring Example of MP-Series Electric Cylinder to Kinetix 6200 and Kinetix 6500 Drive

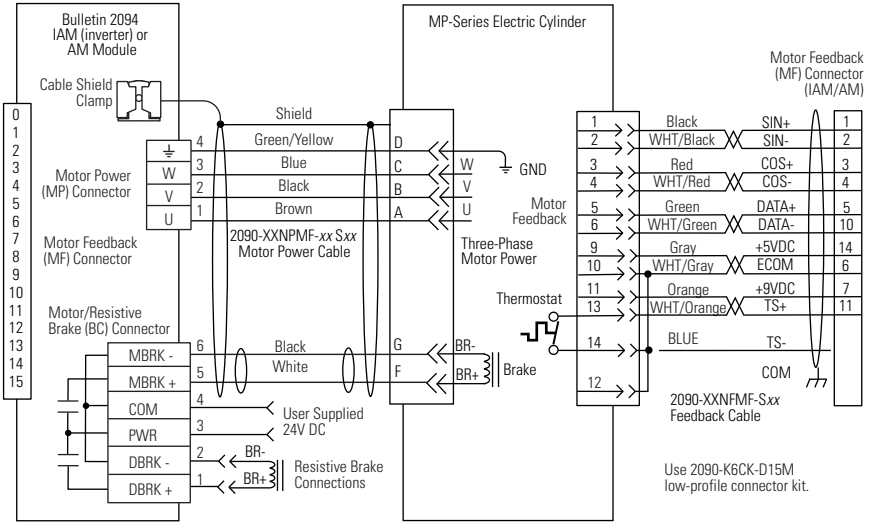

Wiring Example of MP-Series Electric Cylinder to Kinetix 2000 Drive

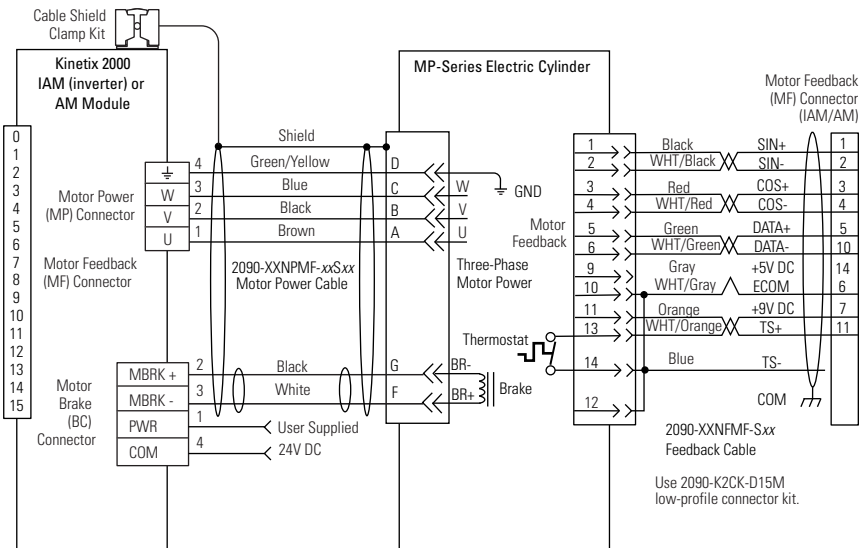

Wiring Example of MP-Series Electric Cylinder to Ultra3000 Drive

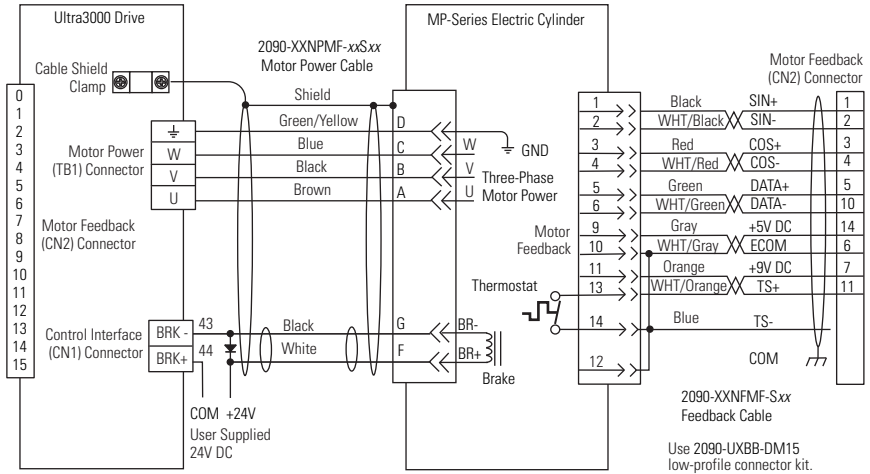

Wiring Example of MP-Series Electric Cylinder to Kinetix 300 Drive

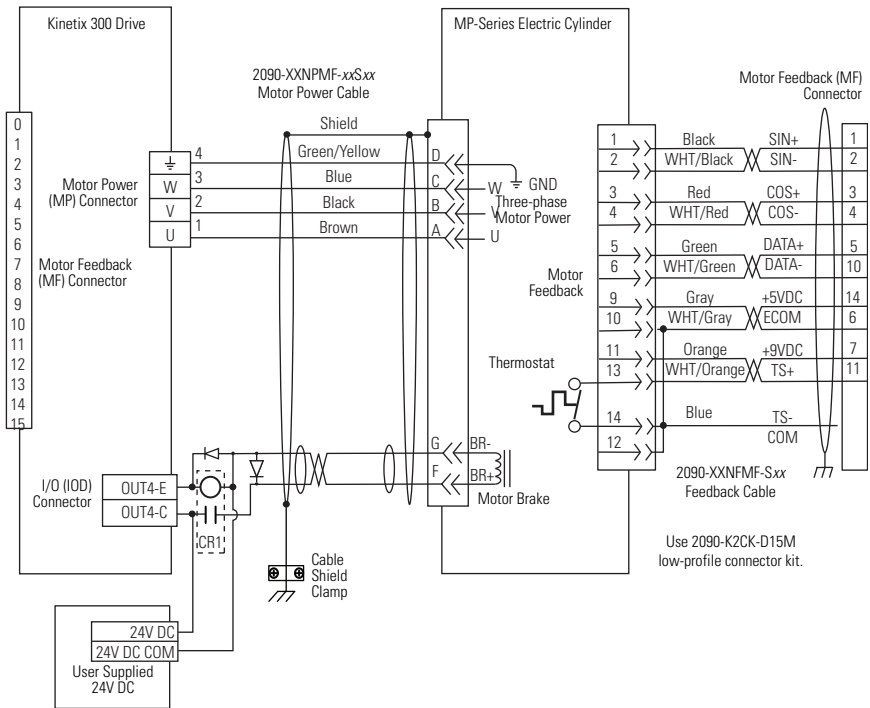

Ground Techniques for Feedback Cable Shield

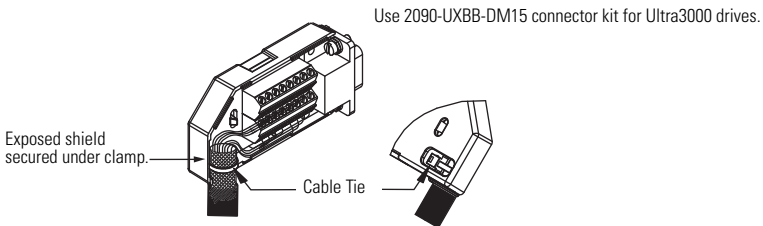
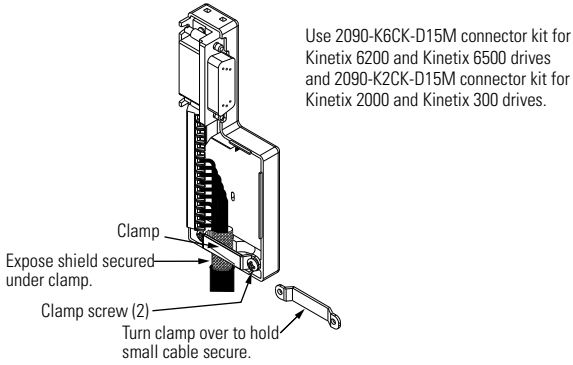

Additional Resources

These documents contain additional information concerning related Rockwell Automation products.

Resource	Description
MP-Series and TL-Series Electric Cylinder Replacement Parts Installation Instructions, publication MPAR-IN002	Information on replacing actuator cylinders, motors, couplings, and belts.
MP-Series Brushless Servo Motor Installation Instructions, publication MP-IN001	Information on installing, 100 mm...165 mm frame size MP-Series low-inertia motors.
MP-Series Brushless Servo Motor Installation Instructions, publication MP-IN006	Information on installing, small frame (≤ 75 mm) MP-Series low-inertia motors.
Kinetix 2000 Multi-axis Servo Drive User Manual, publication 2093-UM001	Information on installing, configuring, startup, and troubleshooting a servo drive system with an Product Name/Title motor and a Kinetix 2000 drive.
Ultra3000 Digital Servo Drives Installation Manual, publication 2098-IN003	How to install, set up, and troubleshoot an Ultra3000 drive.
Ultra3000 Digital Servo Drives Integration Manual, publication 2098-IN005	
Kinetix 6000 Multi-axis Servo Drives User Manual, publication 2094-UM001	Information on installing, configuring, startup, and troubleshooting a servo drive system with an Product Name/Title motor and a Kinetix 6000 drive.
Kinetix 300 EtherNet/IP Indexing Servo Drives User Manual, publication 2097-UM001	Information on installing, configuring, startup, and troubleshooting a servo drive system with an Product Name/Title motor and a Kinetix 300 drive.
Kinetix 6200 and Kinetix 6500 Modular Multi-axis Servo Drive User Manual, publication 2094-UM002	Information on installing, configuring, startup, and troubleshooting a servo drive system with an electric cylinders and a Kinetix 6200 or Kinetix 6500 drive.
Motion Analyzer Software, download at http://www.rockwellautomation.com/en/e-tools	Drive and motor sizing with application analysis software.
SERCOS and Analog Motion Configuration and Startup, publication MOTION-UM001	Information on configuring and troubleshooting your ControlLogix and CompactLogix SERCOS interface modules, and using the home to torque-level sequence.
System Design for Control of Electrical Noise Reference Manual, publication GMC-RM001	Information, examples, and techniques designed to minimize system failures caused by electrical noise.
Kinetix Motion Control Selection Guide, publication GMC-SG001	Specifications, motor/servo-drive system combinations, and accessories for Kinetix motion control products.

You can view or download publications at <http://www.rockwellautomation.com/literature>. To order paper copies of technical documentation, contact your local Rockwell Automation distributor or sales representative.

Allen-Bradley, Kinetix, MP-Series, Rockwell Software, Rockwell Automation, TL-Series, and Ultra3000 are trademarks of Rockwell Automation, Inc.

Trademarks not belonging to Rockwell Automation are property of their respective companies.

Rockwell Otomasyon Ticaret A.Ş., Kar Plaza İş Merkezi E Blok Kat:6 34752 İçerenköy, İstanbul, Tel: +90 (216) 5698400

www.rockwellautomation.com

Power, Control and Information Solutions Headquarters

Americas: Rockwell Automation, 1201 South Second Street, Milwaukee, WI 53204 USA, Tel: (1) 414.382.2000, Fax: (1) 414.382.4444

Europe/Middle East/Africa: Rockwell Automation, Vorstaan/Boulevard du Souverain 36, 1170 Brussels, Belgium, Tel: (32) 2 663 0600, Fax: (32) 2 663 0640

Asia Pacific: Rockwell Automation, Level 14, Core F, Cyberport 3, 100 Cyberport Road, Hong Kong, Tel: (852) 2887 4788, Fax: (852) 2508 1846

Rockwell Automation Publication MPAR-IN001B-EN-P - April 2010

814065

Supersedes Publication MPAR-IN001A-EN-P - May 2009

Copyright © 2010 Rockwell Automation, Inc. All rights reserved. Printed in the U.S.A.