

User's Manual

LR-500 Programmable Display Receiver
LR-400 Display Receiver
LR-300 Receiver

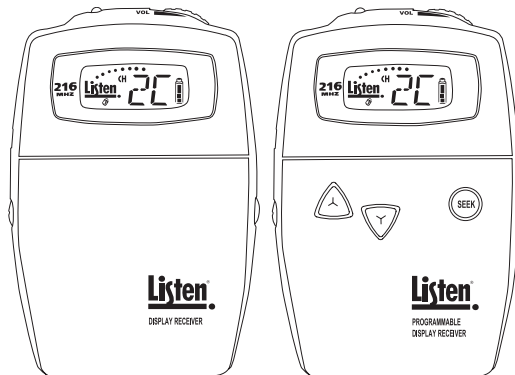

Listen[®]

www.ListenTech.com

Listen Technologies Corporation
8535 South 700 West, Suite A
Sandy, Utah 84070-2515 USA
Telephone: +1.801.233.8992
Toll Free (North America): 1.800.330.0891
Fax: +1.801.233.8995
E-mail: info@ListenTech.com

Listen[®] and the Listen logo are registered trademarks of Listen Technologies Corporation

Don't miss a single sound. Listen.

Welcome to Listen!

Dear Valued Customer,

Thank you for choosing Listen! All of us at Listen are dedicated to providing you the highest quality products and prompt, efficient customer care. Our products are manufactured in an ISO-9000 factory that has been independently certified to the highest quality standards. We stand ready to answer any questions you might have during installation or in the operation of our products. Should there be any problems with your Listen products, we are ready to help you in any way we can. Should you have any comments on how we might improve our products or our service, we're here to listen. Here's how to reach us:

Telephone: +1.801.233.8992
Fax: 1.801.233.8995
Toll Free (North America): 1.800.330.0891
E-Mail: support@listentech.com
Web: www.ListenTech.com

Thank you... and enjoy your listening experience!

Best regards,

The Listen Team



Receivers Table of Contents

LR-500 User’s Manual 3
 LR-500 Table of Contents 5
LR-400 User’s Manual 23
 LR-400 Table of Contents 25
LR-300 User’s Manual 41
 LR-300 Table of Contents 43
Supplementary Information 55
 Channel Selection 56
 Listen SQ™ 58
 RF Reception Maximization Strategies 59
 72 MHz Frequency Compatibility Table 60
 216 MHz Frequency Compatibility Table 62
 Troubleshooting 64
 Compliance Notice 67
 FCC Statement 68
 Warranty 69
 Optional Accessories 70

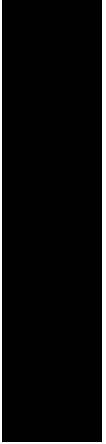

this page intentionally left blank

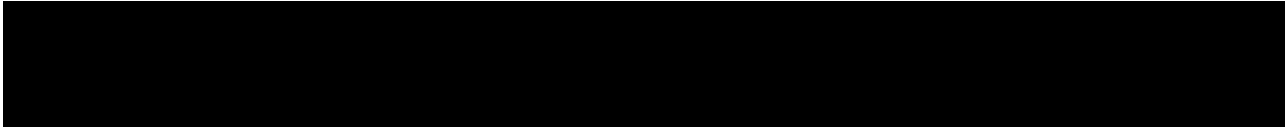

User's Manual

LR-500 Programmable Display Receiver

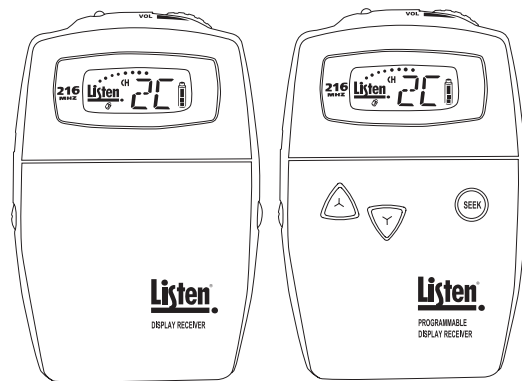

Listen[®]

www.ListenTech.com

Listen Technologies Corporation
8535 South 700 West, Suite A
Sandy, Utah 84070-2515 USA
Telephone: +1.801.233.8992
Toll Free (North America): 1.800.330.0891
Fax: +1.801.233.8995
E-mail: info@ListenTech.com

Don't miss a single sound. Listen.

LR-500 Package Contents

- LR-500 (72MHz or 216MHz)
- Warranty Card
- Receiver User Manual



Listen Part Number

72 MHz: LR-500-072
216 MHz: LR-500-216

Optional Accessories

See pages 70-71.

LR-500 Table of Contents

Architectural Specifications	6
Specifications	6
Quick Reference	8
Setup Instructions	11
Operation Instructions	14
Programming Instructions	16
Squelch Information	17
Squelch Programming	18
Charging Batteries	19
Wall Transformer Operation	21
Supplementary Information	55
Channel Selection	56
Listen SQ™	58
RF Reception Maximization Strategies	59
72 MHz Frequency Compatibility Table	60
216 MHz Frequency Compatibility Table	62
Troubleshooting	64
Compliance Notice	67
FCC Statement	68
Warranty	69
Optional Accessories	70

LR-500 Specifications

Architectural Specifications

The FM receiver shall be capable of receiving on 57 wide and narrow band channels with a SNR of 80dB or greater. The receiver shall be programmable to electronically lock out unneeded channels. The receiver shall be capable of seeking channels. The device shall have an adjustable squelch. The device shall have an audio frequency response of 63Hz to 15KHz, $\pm 3\text{dB}$ at 72MHz, or of 63Hz to 10kHz, $\pm 3\text{dB}$ at 216MHz. The device will incorporate a stereo headset jack that allows the user to plug in either a mono or stereo headset. The device shall incorporate an LCD display that indicates channel, channel lock or lock status, battery level, low battery, battery charging, and RF signal strength. The receiver shall incorporate automatic battery charging circuitry for recharging of NiMH batteries. The Listen LR-500 is specified.

Specifications

Specification		LR-500-072	LR-500-216
RF	RF Frequency Range	72.025 - 75.950 MHz	216.025 - 216.975 MHz
	Number of Channels	57 (17 wide, 40 narrow)	57 (19 wide, 38 narrow)
	Sensitivity	.6uV typical, 1 uV maximum for 12dB SINAD	
	Frequency Accuracy	$\pm .005\%$ stability 0° to 50°C (32° to 122° F)	
	Antenna	Uses earphone cable	
	Antenna Connector	3.5mm connector	
	Squelch	Programmable in 20 steps	
Compliance	FCC Part 15, Industry Canada		
** All system specifications are wireless end-to-end			
Audio	System Frequency Response	63Hz - 15kHz ($\pm 3\text{dB}$)	63Hz - 10kHz ($\pm 3\text{dB}$)
	System Signal to Noise Ratio (A-weighted)	SQ enabled: 80dB; SQ disabled 60dB	SQ enabled: 80dB; SQ disabled 50dB
	System Distortion	<2% total harmonic distortion (THD) at 80% deviation	
	Output	3.5mm connectors, unbalanced, 0dBu nominal output level, 16mW maximum, Impedance 32 Ohms	

continued on next page

LR-500 Specifications continued

Specification		LR-500-072	LR-500-216
Controls	Set Up Controls	Programmable channel selection (see below), alkaline/NIMH batteries and squelch, SQ enable/disable	
	User Controls	Volume, channel UP/DOWN, SEEK. All controls except volume are electronically lockable.	
	Programming	Unit can be programmed so that only desired channels are displayed. Squelch can be adjusted for sensitivity and signal capture control. Channel selection can be locked by holding the SEEK button 5 seconds.	
Indicators	LCD Display	Indicates channel, RF signal strength, lock status, squelch, battery power level and channel programming.	
	LED	Red, illuminates when unit is on. Flashes when batteries are low. Flashes when charging. Flashes when locked and user attempts to seek to another channel	
Power	Battery Type	Two AA batteries, alkaline or NIMH	
	Battery Life (Listen batteries)	30 hours alkaline (LA-361), 15 hours NIMH rechargeable (LA-362)	
	Battery Charging (NIMH only)	Fully automatic, 14 hours	
	Power Supply Connector	2.3mm OD by 0.7mm ID, barrel type connector. 7.5VDC, center positive <250mA. Drop in contact points for use with Listen charging cases.	
	Compliance	UL Listed	
Physical	Dimensions	3.0 in x 1.0 in x 5 in WxDxH (7.6cm x 2.5cm x 13.cm)	
	Unit Weight	3.9oz (111g)	
	Unit Weight with batteries	5.8 oz (164.4g)	
	Shipping Weight	1.0 lbs (453.6kg)	
	Door	Manually lockable. UP, DOWN and SEEK through door, other controls behind door (see Controls above).	
Environmental	Temperature - Operation	-10° to 40°C (14° to 104° F)	
	Temperature - Storage	-20° to 50°C (-4° to 122° F)	
	Humidity	0 to 95% relative humidity, non-condensing	

Quick Reference

LR-500 Front

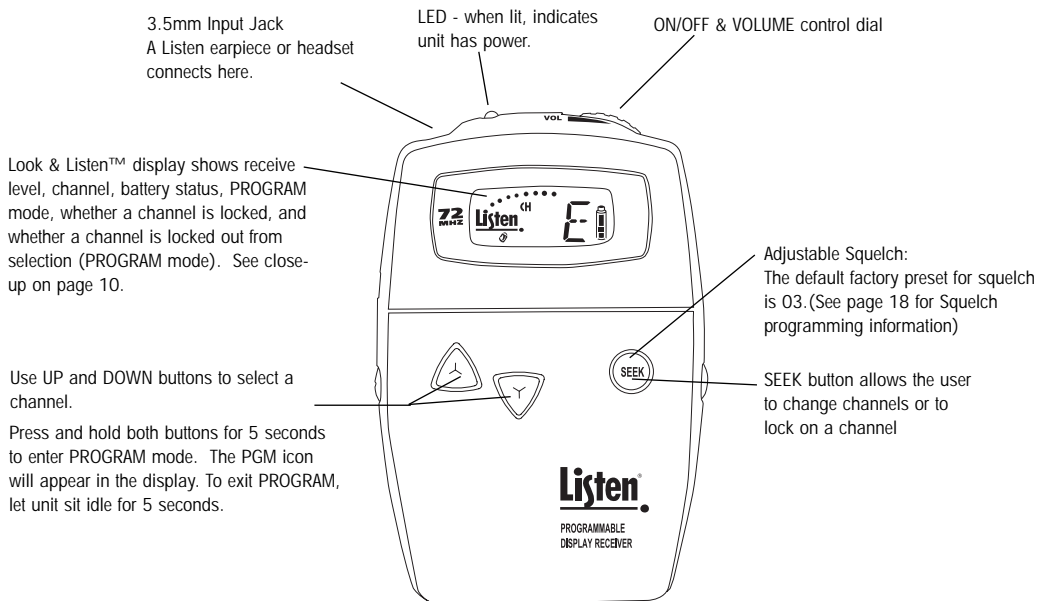

Quick Reference
LR-500 Inside Access Door

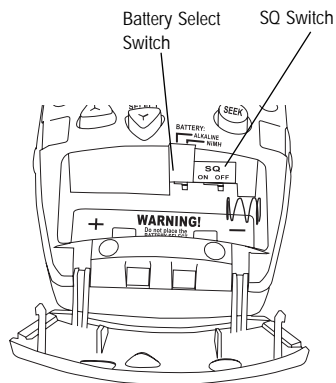

Battery Select Switch - place in NiMH position ONLY if you are using Nickel Metal Hydride batteries, otherwise, leave it in the Alkaline position.

SQ Switch: shipped in the ON position, use a screwdriver or pen to slide to the OFF position if needed. You should turn SQ off if any of your receivers do not have SQ.

LR-500 Top of Unit

LED indicators

- Steady Red: Normal operation
- Slow Flashing: Battery is low
- Slow Flashing while charging: Unit is charging

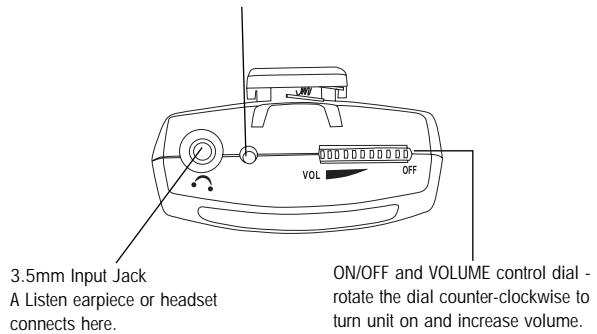

Quick Reference LR-500 Look & Listen™ Display

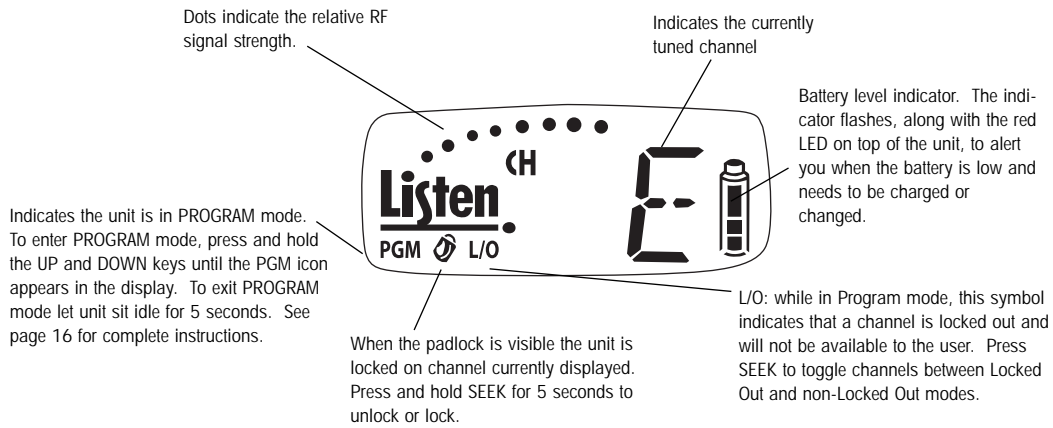

LR-500 Battery Indicator



All three segments showing:
The batteries are at 50% or greater capacity.



Two segments showing:
The batteries are at 25-49% capacity.



One segment showing:
Your batteries less than 25% capacity. When this segment begins flashing along with the LED on top of the unit, you should immediately change your batteries or recharge them (if using NiMH batteries).

LR-500 Setup Instructions

1 Remove the product

Remove outer packaging and plastic cover. Inspect for physical damage. If damage is apparent, please contact Listen Technologies Corporation technical support for assistance. See page 69 for contact information.

2 Open the front access door

If locked, use a pocketknife or small screwdriver to unlock the door locks on both sides of the unit. To unlock the door, rotate the lock $\frac{1}{4}$ turn counterclockwise.

Grip the two tabs with your thumb and index finger and pull the door downward. Do NOT place batteries in the unit yet.

3 Select Battery Type

See diagram on page 9. You have two choices: NiMH and Alkaline. The unit is shipped with the switch in the Alkaline position. Use a pen or small screwdriver to select the battery type.

CAUTION: If you are using any battery type other than rechargeable Nickel Metal Hydride (NiMH) batteries, make sure the BATTERY selection switch is in the alkaline position.

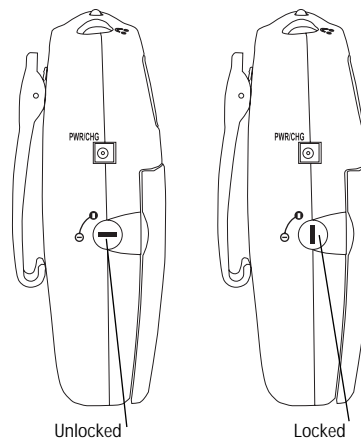

WARNING: Do not place the BATTERY switch in the NiMH position if you are not using Nickel Metal Hydride Batteries. The NiMH position will attempt to charge any batteries in the unit, even if they are not the proper type. Charging non-Nickel Metal Hydride (NiMH) batteries will result in physical harm, destruction of property and/or fire.

LR-500 Setup Instructions continued

3 Set SQ switch

The SQ switch is inside the battery compartment next to the Battery Select switch. The unit is shipped with SQ in the ON position. To turn it off, use a small screwdriver or pen to slide the switch to the OFF position (to the right). See page 58 for more information on SQ.

4 Place Batteries in Unit

Place two AA batteries in the compartment, making note of the battery polarity shown in the battery compartment, and again verifying that the BATTERY SELECT switch is in the correct position for the batteries you are using. (ALK should be selected for all battery types other than NiMH).

NOTE: Listen uses 1800mAh (milli-Amp-hour) constant current NiMH (Nickel Metal Hydride) batteries. These may be purchased from your Listen dealer (ask for part number LA-362).

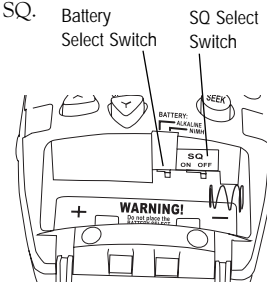

LR-500 Setup Instructions continued

6 Connect an Earphone or Headset

Your headset or earphone will connect to the jack on the top of the unit. Either mono or stereo connectors may be used with a Listen receiver. Make certain you push the plug all the way into the jack.

7 Turn the Unit On

Receivers are turned on by rotating the volume dial counterclockwise. The red LED on top of the unit should activate and the LCD display should illuminate. If they do not, make sure you have installed the batteries correctly and that you are using fully charged batteries.

8 Select Channel(s)

See page 56 for complete channel selection information.

9 Set Squelch

See pages 17 and 18 for squelch and programming information.

10 Program Channels

see page 16.

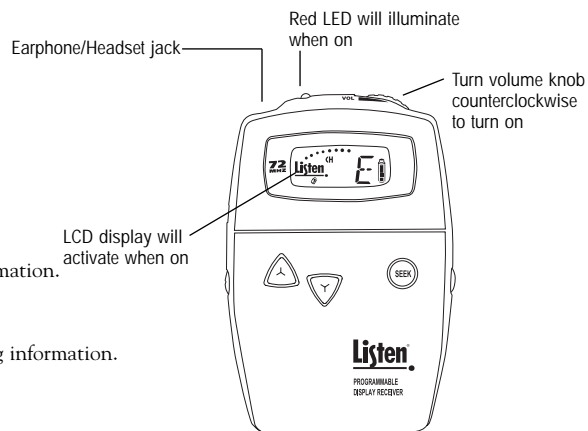

LR-500 Operation Instructions

1 Make Sure the Unit is On

Rotate the volume knob counterclockwise with an earphone or headset connected to the unit. Listen receivers use the cable of the earphone or headset as a receiving antenna.

Be careful when turning the unit on - if you turn the knob too far you might get too much volume in your earphone!

2 Select a Channel

Select the channel to match the transmission channel by pressing the UP and DOWN buttons on the receiver.

At 72MHz:

72MHz receivers operate on 17 wide band channels and 40 narrow band channels. Channels represented by letters on the display (i.e. A) are wideband channels ; channels represented by numbers are narrowband channels.

At 216MHz:

216MHz receivers operate on 19 wide band channels and 38 narrow band channels. Channel numbers starting with a "2" are wide band; channels beginning with a "1" or "3" are narrow band channels.

Refer to the Frequency Compatibility Tables (pages 60-63) for specific frequencies and compatibility with other manufacturers.

NOTE: Listen recommends the use of wide band transmitters.

3 Test the audio

If a transmitter is broadcasting on that channel, you will be able to hear the audio. If the signal is too weak, the audio will be muted (squelched).

LR-500 Operation Instructions continued

4 Find an audio transmission using SEEK

Another way to find a channel on the LR-500 is to use the SEEK button. When you do this, the Listen receiver looks for the next active channel. Sometimes the unit will mistake interference for a real broadcast signal. If you get interference, press the SEEK button again. The unit may stop on a channel that is close to the actual broadcast channel, in which case the channel will sound noisy or distorted. Simply press SEEK again until you find the clearest operating channel.

5 Adjust the volume control

Use the control dial on the top of the unit to adjust the volume to a comfortable level.

6 To Lock into Only One Channel

Press and hold the SEEK button for 5 seconds to lock a receiver onto the currently tuned channel. Press and hold the button again to unlock. When locked the LED on top of the unit will flash when you press the SEEK button.

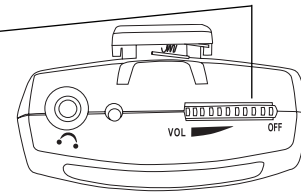

Is the Channel Locked on My Receiver?

On the LR-500, when the channel is locked, the padlock icon will appear on the display. If the unit is locked, the red LED on the top of the unit will flash when you press the SEEK button.

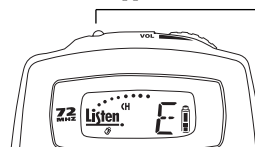
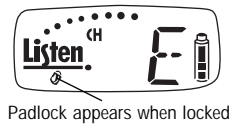

If locked, LED flashes on all portable receivers when SEEK button is pressed.

LR-500 Programming Instructions

The LR-500 Display Receiver has some special features not available in the other receivers: you may lock out unwanted channels, and you can adjust the squelch in the unit.

Locking Out Unwanted Channels

For applications where users are required to select a channel (such as language interpretation or classrooms), and you don't want them to have to go through all 57 available channels to find the appropriate channel, you can lock out all channels except the ones you are using in your facility.



UP and DOWN buttons on front of LR-500

1 Enter the PROGRAM mode

Press the UP and DOWN buttons simultaneously for 5 seconds, until the PGM symbol appears in the display.

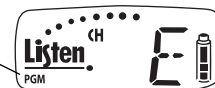

2 Use the UP and DOWN keys to select channels

As channels are displayed on the unit, those channels that are locked out from user access will be indicated by the L/O (Locked Out) symbol. When a channel is locked out, the receiver will skip over that channel when a user is tuning the receiver.

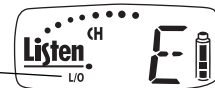

3 Press the SEEK button to toggle channels between locked out and non-locked out modes

Exiting PROGRAM mode

To exit the PROGRAM mode, let the receiver sit idle (don't press any buttons) for 5 seconds. The receiver will automatically return to normal operation. If you haven't finished programming the unit and it automatically exits, press and hold the UP & DOWN buttons simultaneously for 5 seconds to re-enter the PROGRAM mode.

LR-500 Squelch

Squelch

The purpose of squelch is to mute the audio output of your receiver when the signal from the transmitter is turned off or is too weak to be received. Without squelch you would hear radio noise in your earphone. The squelch on your receiver can be adjusted so that it will mute the audio on different RF signal strengths. This is useful as follows:

- To ensure that users don't hear transmissions from other transmitters, set the squelch setting to the highest level that doesn't squelch the receiver.
- If the receiver is going to be close to the transmitter (i.e. in a classroom), setting the squelch setting high so that when the transmitter is turned off it immediately squelches and ignores transmitters in other rooms.
- If you are in an area that has a lot of inference, you may want to set the squelch setting to a high setting to ensure the interference is not picked by the receiver.
- If you need the maximum amount of range, you may want to consider setting the squelch setting to a low level (0, 1 or 2). CAUTION: when setting the squelch level low the reliability of squelch function is comprised. This will cause radio noise to be heard in the earphone and there is a possibility of hearing damage.

Squelch Programming Instructions

Squelch Programming

To enter Squelch programming mode

- Turn the unit off
- Press and hold the seek button; while still holding seek turn the ON/OFF dial to turn the unit on.
- Release the seek button when the Listen name disappears and a two digit display is seen.

To adjust the Squelch level

- Use the Channel UP and DOWN buttons to raise or lower the squelch sensitivity settings.
- Lower numbers mean that a less powerful and possibly noisy signal will be heard, but you can have a longer range.
- Higher numbers mean that a more powerful signal with no noise will be heard, but you may have a shorter range.

Squelch setting 00 is no squelch; this effectively disables Squelching capabilities of the receiver. Squelch setting 20 is maximum squelch sensitivity; you must have a very strong and stable RF signal for the unit to not engage the squelch feature.)

Adjusting the squelch setting will keep your LR-500 receiver from picking up noise when the transmitter is not transmitting, or when you lose the signal by being out of range or if encountering interference.

Note: For squelch settings 1-3, the squelch function is slow which allows for maximum transmission range. For squelch settings 4-20 the squelch function is fast to ensure little radio noise is heard during the squelch function.

(The Listen SQ feature is not squelch, please refer to page 58 for information on Listen SQ).

LR-500 Charging Batteries

The LR-500 and all Listen receivers are unique because they have SmartCharge™ chargers built in. When any of these units are connected to an LA-202 wall transformer or dropped into a Listen charging case, NiMH batteries will be charged.

- 1 To charge the batteries using the LA-202 wall transformer, plug the transformer into the jack marked “PWR/CHG” on the side of the unit. The unit can be operated while the batteries are charging.
- 2 To charge the batteries using a drop-in charger, simply place the unit into a slot in the charger and connect the charger to power. Make sure the unit is fully seated in its slot.

One of several charging cases available from Listen. Check the Listen website for more details.

SmartCharge™ uses a pulse charging, which greatly extends the life of Nickel Metal Hydride (NiMH) batteries. The entire charging process takes 13 hours. Listen recommends that you allow the charger to complete its full cycle every time for maximum battery life.

IMPORTANT: DO NOT ATTEMPT TO CHARGE ANY TYPE OF BATTERY OTHER THAN NiMH (NICKEL METAL HYDRIDE) with your Listen equipment. Alkaline batteries may explode when connected to a charger. Other risks of charging non-NiMH batteries include destruction of property or fire.

IMPORTANT: In order to charge NiMH batteries, the BATTERY SELECT switch in your Listen product must be set to the NiMH setting. Use a pen or small screwdriver to move the switch (located in the battery compartment) to the proper position.

Connect LA-202 here and plug it into an AC wall outlet.

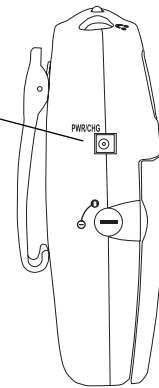

LR-500 Charging Batteries continued

During the charge cycle, the red LED on top of the Listen product will flash slowly. When charging is completed, the LED will turn off. It is not necessary to unplug the charger; however, if you unplug the unit from the charger and then plug it back in, it will begin the 13-hour charge cycle over again.

When not using the LR-500, it is recommended to leave the unit on the charger. The charger provides a “maintenance” charge that keeps the battery at 100%. If the unit is not on the charger, the battery will lose up to 20% of its charge per month.

NOTE: Listen uses 1800mAh (milli-Amp-hour) constant current NiMH (Nickel Metal Hydride) batteries. These may be purchased from your Listen dealer (ask for part number LA-362).

One of several charging cases available from Listen. See www.ListenTech.com for more options.

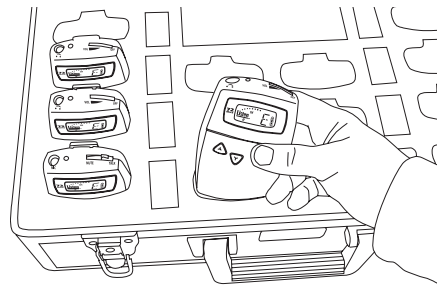

LA-311 - 16-unit Drop In Charging Case shown

LR-500 Wall Transformer Operation

The LR-500 will operate normally when connected to a wall transformer. Use Listen part number LA-202, available from any Listen dealer. Connect the wall transformer to the jack on the side of the LR-500 marked "PWR/CHG" and plug the wall transformer into a grounded AC outlet.

You do not need to have batteries installed in the LR-500 to operate it with a wall transformer.

NOTE: If batteries are in the unit ensure that the battery selection switch is set properly as shown on page 9. Please review the information on page 19 for important information regarding battery type and charging.

The LA-202 wall transformer plugs into the side of your portable transmitter or receiver.

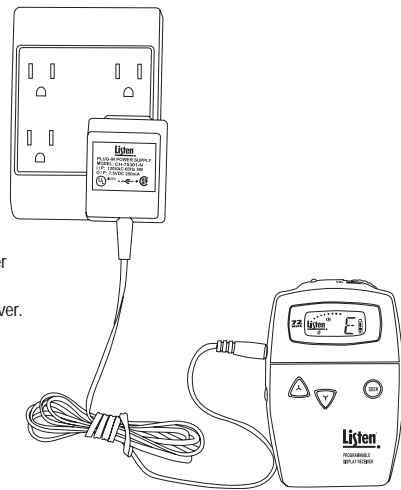

this page intentionally left blank

User's Manual

LR-400 Display Receiver

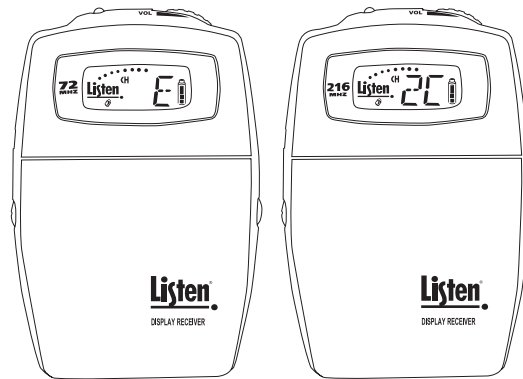

Listen[®]

www.ListenTech.com

Listen Technologies Corporation
8535 South 700 West, Suite A
Sandy, Utah 84070-2515 USA
Telephone: +1.801.233.8992
Toll Free (North America): 1.800.330.0891
Fax: +1.801.233.8995
E-mail: info@ListenTech.com

Don't miss a single sound. Listen.

LR-400 Package Contents

- LR-400 (72MHz or 216MHz)
- Warranty Card
- Receiver User Manual

Listen Part Number

72 MHz: LR-400-072
216 MHz: LR-400-216



Optional Accessories

See pages 70-71.

LR-400 Table of Contents

Architectural Specifications26

Specifications26

Quick Reference28

Setup Instructions31

Operation Instructions34

Squelch Information36

Squelch Programming37

Charging Batteries38

Wall Transformer Operation40

Supplementary Information55

Channel Selection56

Listen SQ™58

RF Reception Maximization Strategies59

72 MHz Frequency Compatibility Table60

216 MHz Frequency Compatibility Table62

Troubleshooting64

Compliance Notice67

FCC Statement68

Warranty69

Optional Accessories70

LR-400 Specifications

Architectural Specifications

The FM receiver shall be capable of receiving on 57 wide and narrow band channels with a SNR of 80dB or greater. The receiver shall be capable of seeking channels. The device shall have an adjustable squelch. The device shall have an audio frequency response of 63Hz to 15KHz, ± 3 dB at 72MHz, or of 63Hz to 10kHz, ± 3 dB at 216MHz. The device will incorporate a stereo headset jack that allows the user to plug in either a mono or stereo headset and listen to the audio normally. The device shall incorporate an LCD display that indicates channel, battery level, low battery, battery charging, RF signal strength and channel lock status. The receiver shall incorporate automatic battery charging circuitry for recharging of NiMH batteries. The Listen LR-400 is specified.

Specifications

Specification		LR-400-072	LR-400-216
RF	RF Frequency Range	72.025 - 75.950 MHz	216.025 - 216.975 MHz
	Number of Channels	57 (17 wide, 40 narrow)	57 (19 wide, 38 narrow)
	Sensitivity	.6uV typical, 1 uV maximum for 12dB SINAD	
	Frequency Accuracy	$\pm .005\%$ stability 0° to 50°C (32° to 122° F)	
	Antenna	Uses earphone cable	
	Antenna Connector	3.5mm connector	
	Squelch	Programmable in 20 steps	
Compliance	FCC Part 15, Industry Canada		
** All system specifications are wireless end-to-end			
Audio	System Frequency Response	63Hz - 15kHz (± 3 dB)	63Hz - 10kHz (± 3 dB)
	System Signal to Noise Ratio (A-weighted)	SQ enabled: 80dB; SQ disabled 60dB	SQ enabled: 80dB; SQ disabled 50dB
	System Distortion	<2% total harmonic distortion (THD) at 80% deviation	
	Output	3.5mm connectors, unbalanced, 0dBu nominal output level 16mW maximum, impedance 32 Ohms	

LR-400 Specifications continued

	Specification	LR-400-072	LR-400-216
Controls	Set Up Controls	Alkaline/NIMH batteries and SQ enable/disable and programmable squelch setting.	
	User Controls	Volume, channel UP/DOWN, SEEK (All controls except volume are electronically lockable, and are behind the door)	
	Programming	Squelch can be adjusted for sensitivity and signal capture control. Channel selection can be locked by holding the SEEK button for 5 seconds. Unit cannot be programmed, however, it is capable of entering squelch mode.	
Indicators	LCD Display	Indicates channel, RF signal strength, lock status, and squelch setting.	
	LED	Red, illuminates when unit is on. Flashes when batteries are low. Flashes when charging. Flashes when locked and user attempts to seek to another channel.	
Power	Battery Type	Two AA batteries, alkaline or NIMH	
	Battery Life (Listen batteries)	30 hours alkaline (LA-361), 15 hours NIMH rechargeable (LA-362)	
	Battery Charging (NIMH only)	Fully automatic, 14 hours	
	Power Supply Connector	2.3mm OD by 0.7mm ID, barrel type connector, 7.5VDC, center positive <250mA. Drop in contact points for use with Listen charging/carrying cases.	
	Compliance	UL Listed	
Physical	Dimensions	3.0 in x 1.0 in x 5 in WxDxH (7.6cm x 2.5cm x 13.cm)	
	Unit Weight	3.9oz (111g)	
	Unit Weight with batteries	5.8 oz (164.4g)	
	Shipping Weight	1.0 lbs (453.6kg)	
	Door	Manually lockable. UP, DOWN and SEEK protected by door.	
Environmental	Temperature - Operation	-10° to 40°C (14° to 104° F)	
	Temperature - Storage	-20° to 50°C (-4° to 122° F)	
	Humidity	0 to 95% relative humidity, non-condensing	

Quick Reference
LR-400 Front

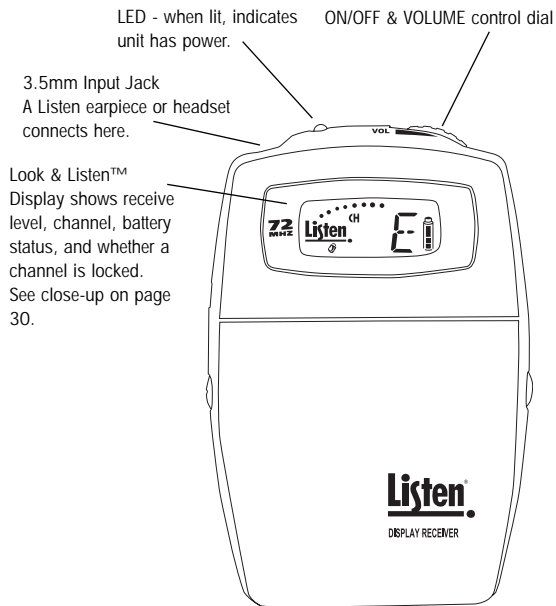

LR-400 Top of Unit

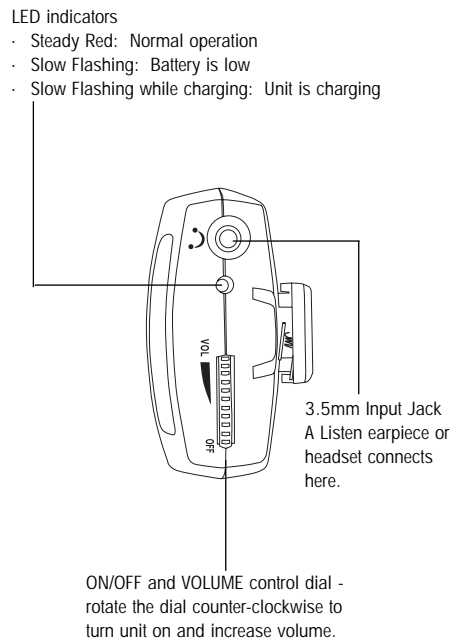

Quick Reference
LR-400 Inside Access Door

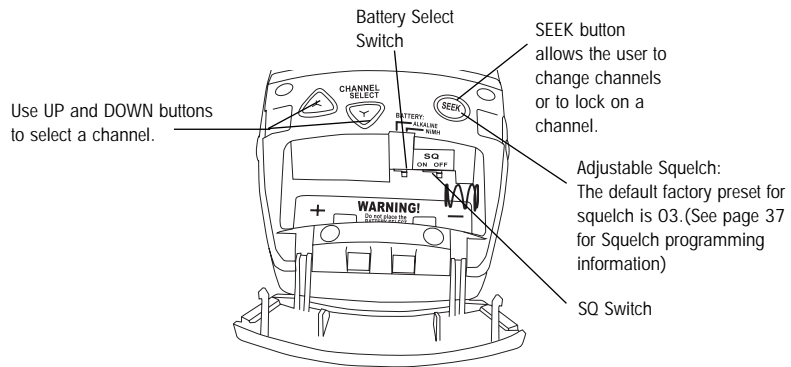

Use UP and DOWN buttons to select a channel.

Battery Select Switch

SEEK button allows the user to change channels or to lock on a channel.

Adjustable Squelch: The default factory preset for squelch is 03. (See page 37 for Squelch programming information)

SQ Switch

Battery Select Switch - place in NiMH position ONLY if you are using Nickel Metal Hydride batteries, otherwise, leave it in the Alkaline position.

SQ Switch: shipped in the ON position, use a screwdriver or pen to slide to the OFF position if needed. You should turn SQ off if any of your receivers do not have SQ.

Quick Reference

LR-400 Look & Listen™ Display

Dots indicate the relative RF signal strength. When there is a full signal the unit will display all 8 dots.

Indicates the currently tuned channel

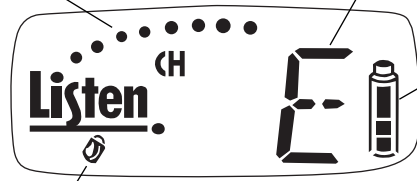

Battery level indicator. The indicator flashes, along with the red LED on top of the unit, to alert you when the battery is low and needs to be charged or changed.

When the padlock is visible, the channel is locked. Press and hold SEEK for 5 seconds to unlock or lock.

LR-400 Battery Indicator



All three segments showing: The batteries are at 50% or greater capacity.



Two segments showing: The batteries are at 25-49% capacity.



One segment showing: Your batteries less than 25% capacity. When this segment begins flashing along with the LED on top of the unit, you should immediately change your batteries or recharge them (if using NiMH batteries).

LR-400 Setup Instructions

1 Remove the product

Remove outer packaging and plastic cover. Inspect for physical damage. If damage is apparent, please contact Listen Technologies Corporation technical support for assistance. See page 69 for contact information.

2

Open the front access door

If locked, use a pocketknife or small screwdriver to unlock the door locks on both sides of the unit. To unlock the door, rotate the lock $\frac{1}{4}$ turn counterclockwise.

Grip the two tabs with your thumb and index finger and pull the door downward. Do NOT place batteries in the unit yet.

3 Select Battery Type

See diagram on page 29. You have two choices: NiMH and Alkaline. The unit is shipped with the switch in the Alkaline position. Use a pen or small screwdriver to select the battery type.

CAUTION: If you are using any battery type other than rechargeable Nickel Metal Hydride (NiMH) batteries, make sure the BATTERY selection switch is in the alkaline position.

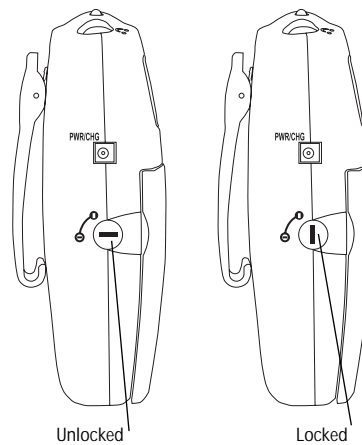

WARNING: Do not place the BATTERY switch in the NiMH position if you are not using Nickel Metal Hydride Batteries. The NiMH position will attempt to charge the batteries. Charging non-Nickel Metal Hydride batteries may result in physical harm, destruction of property and/or fire.

LR-400 Setup Instructions continued

4 Set SQ switch

The SQ switch is inside the battery compartment next to the Battery Select switch. The unit is shipped with SQ in the ON position. To turn it off, use a small screwdriver or pen to slide the switch to the OFF position (to the right). See page 58 for more information on SQ.

5 Place Batteries in Unit

Place two AA batteries in the compartment, making note of the battery polarity shown in the battery compartment, and again verifying that the BATTERY SELECT switch is in the correct position for the batteries you are using. (ALK should be selected for all battery types other than NiMH).

NOTE: Listen uses 1800mAh (milli-Amp-hour) constant current NiMH (Nickel Metal Hydride) batteries. These may be purchased from your Listen dealer (ask for part number LA-362).

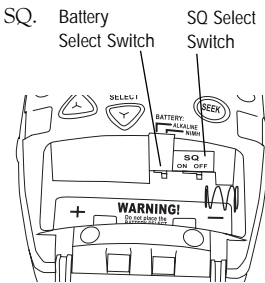

6 Connect an Earphone or Headset

Your headset or earphone will connect to the jack on the top of the unit. Either mono or stereo connectors may be used with a Listen receiver. Make certain you push the plug all the way into the jack.

LR-400 Setup Instructions continued

7 Turn the Unit On

Receivers are turned on by rotating the volume dial counterclockwise. The red LED on top of the unit should activate and the LCD display should illuminate. If they do not, make sure you have installed the batteries correctly and that you are using fully charged batteries.

8 Select Channel(s)

See page 56 for complete channel selection information.

9 Set Squelch

See pages 36 and 37 for squelch and programming information.

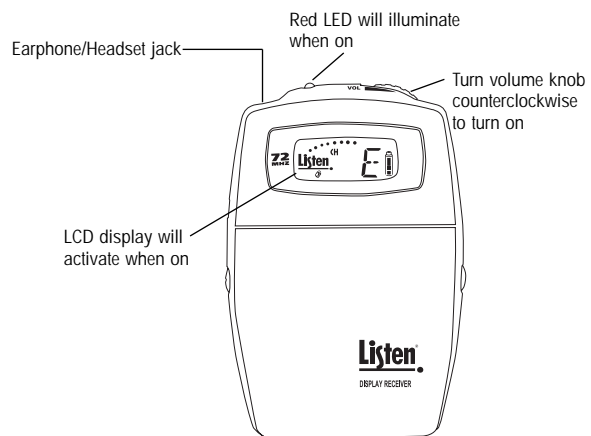

LR-400 Operation Instructions

1 Make Sure the Unit is On

Rotate the volume knob counterclockwise with an earphone or headset connected to the unit. Listen receivers use the cable of the earphone or headset as a receiving antenna.

Be careful when turning the unit on - if you turn the knob too far you might get too much volume in your earphone!

2 Select a Channel

Select the channel to match the transmission channel by pressing the UP and DOWN buttons on the receiver.

At 72MHz:

72MHz receivers operate on 17 wide band channels and 40 narrow band channels. Channels represented by letters on the display (i.e. A) are wideband channels ; channels represented by numbers are narrowband channels.

At 216MHz:

216MHz receivers operate on 19 wide band channels and 38 narrow band channels. Channel numbers starting with a "2" are wide band; channels beginning with a "1" or "3" are narrow band channels.

Refer to the Frequency Compatibility Tables (pages 60-63) for specific frequencies and compatibility with other manufacturers.

3 Test the audio

If a transmitter is broadcasting on that channel, you will be able to hear the audio. If the signal is too weak, the audio will be muted (squelched).

LR-400 Operation Instructions continued

4 Find an audio transmission using SEEK

Another way to find a channel on the LR-400 is to use the SEEK button. When you do this, the Listen receiver looks for the next active channel. Sometimes the unit will mistake interference for a real broadcast signal. If you get interference, press the SEEK button again. The unit may stop on a channel that is close to the actual broadcast channel, in which case the channel will sound noisy or distorted. Simply press SEEK again until you find the clearest operating channel.

5 Adjust the volume control

Use the control dial on the top of the unit to adjust the volume to a comfortable level.

6 To Lock into Only One Channel

Press and hold the SEEK button for 5 seconds to lock a receiver onto the currently tuned channel. Press and hold the button again to unlock. When locked the LED on top of the unit will flash when you press the SEEK button.

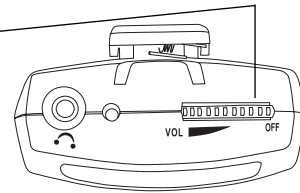

Is the Channel Locked on My Receiver?

On the LR-400, when the channel is locked, the padlock icon will appear on the display. If the unit is locked, the red LED on the top of the unit will flash when you press the SEEK button.

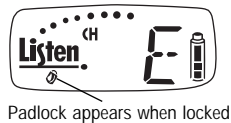

Padlock appears when locked

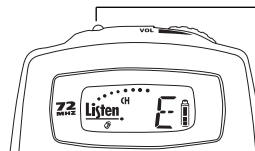

If locked, LED flashes on all portable receivers when SEEK button is pressed.

LR-400 Squelch

Squelch

The purpose of squelch is to mute the audio output of your receiver when the signal from the transmitter is turned off or is too weak to be received. Without squelch you would hear radio noise in your earphone. The squelch on your receiver can be adjusted so that it will mute the audio on different RF signal strengths. This is useful as follows:

- To ensure that users don't hear transmissions from other transmitters, set the squelch setting to the highest level that doesn't squelch the receiver.
- If the receiver is going to be close to the transmitter (i.e. in a classroom), setting the squelch setting high so that when the transmitter is turned off it immediately squelches and ignores transmitters in other rooms.
- If you are in an area that has a lot of inference, you may want to set the squelch setting to a high setting to ensure the interference is not picked by the receiver.
- If you need the maximum amount of range, you may want to consider setting the squelch setting to a low level (0, 1 or 2). **CAUTION:** when setting the squelch level low the reliability of squelch function is comprised. This will cause radio noise to be heard in the earphone and there is a possibility of hearing damage.

Squelch Programming Instructions

Squelch Programming

To enter Squelch programming mode

- Turn the unit off
- Press and hold the seek button; while still holding seek turn the ON/OFF dial to turn the unit on.
- Release the seek button when the Listen name disappears and a two digit display is seen.

To adjust the Squelch level

- Use the Channel UP and DOWN buttons to raise or lower the squelch sensitivity settings.
- Lower numbers mean that a less powerful and possibly noisy signal will be heard, but you can have a longer range.
- Higher numbers mean that a more powerful signal with no noise will be heard, but you may have a shorter range.

To save and exit the squelch programming mode press the seek button.

Squelch setting 00 is no squelch; this effectively disables Squelching capabilities of the receiver. Squelch setting 20 is maximum squelch sensitivity; you must have a very strong and stable RF signal for the unit to not engage the squelch feature.)

Adjusting the squelch setting will keep your LR-400 receiver from picking up noise when the transmitter is not sending audio, or when you lose the signal by being out of range or if encountering interference.

Note: For squelch settings 1-3, the squelch function is slow which allows for maximum transmission range. For squelch settings 4-20 the squelch function is fast to ensure little radio noise is heard during the squelch function.

(The Listen SQ feature is not squelch, please refer to page 58 for information on Listen SQ).

LR-400 Charging Batteries

The LR-400 and all Listen receivers are unique because they have SmartCharge™ chargers built in. When any of these units are connected to an LA-202 wall transformer or dropped into a Listen charging case, NiMH batteries will be charged.

To charge the batteries using the LA-202 wall transformer, plug the transformer into the jack marked “PWR/CHG” on the side of the unit. The unit can be operated while the batteries are charging.

To charge the batteries using a drop-in charger, simply place the unit into a slot in the charger and connect the charger to power. Make sure the unit is fully seated in its slot.

One of several charging cases available from Listen. Check the Listen website for more details.

SmartCharge™ uses a pulse charging, which greatly extends the life of Nickel Metal Hydride (NiMH) batteries. The entire charging process takes 13 hours. Listen recommends that you allow the charger to complete its full cycle every time for maximum battery life.

Connect LA-202 here and plug it into an AC wall outlet.

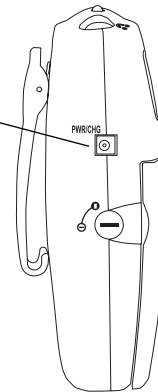

IMPORTANT: DO NOT ATTEMPT TO CHARGE ANY TYPE OF BATTERY OTHER THAN NiMH (NICKEL METAL HYDRIDE) with your Listen equipment. Alkaline batteries may explode when connected to a charger. Other risks of charging non-NiMH batteries include destruction of property or fire.

IMPORTANT: In order to charge NiMH batteries, the BATTERY SELECT switch in your Listen product must be set to the NiMH setting. Use a pen or small screwdriver to move the switch (located in the battery compartment) to the proper position.

LR-400 Charging Batteries continued

During the charge cycle, the red LED on top of the Listen product will flash slowly. When charging is completed, the LED will turn off. It is not necessary to unplug the charger; however, if you unplug the unit from the charger and then plug it back in, it will begin the 13-hour charge cycle over again.

When not using the LR-400, it is recommended to leave the unit on the charger. The charger provides a "maintenance" charge that keeps the battery at 100%. If the unit is not on the charger, the battery will lose up to 20% of its charge per month.

NOTE: Listen uses 1800mAh (milli-Amp-hour) constant current NiMH (Nickel Metal Hydride) batteries. These may be purchased from your Listen dealer (ask for part number LA-362).

One of several charging cases available from Listen. See the www.ListenTech.com for more options.

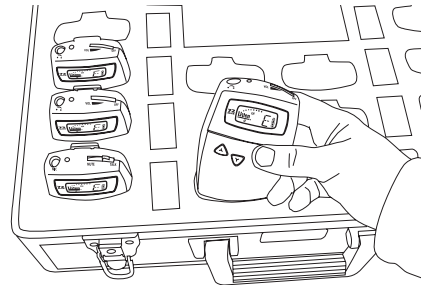

LA-311 - 16-unit Drop In Charging Case shown

LR-400 Wall Transformer Operation

The LR-400 will operate normally when connected to a wall transformer. Use Listen part number LA-202, available from any Listen dealer. Connect the wall transformer to the jack on the side of the LR-400 marked "PWR/CHG" and plug the wall transformer into a grounded AC outlet.

You do not need to have batteries installed in the LR-400 to operate it with a wall transformer.

NOTE: If batteries are in the unit ensure that the battery selection switch is set properly as shown on page 29. Please review the information on page 38 for important information regarding battery type and charging.

The LA-202 wall transformer plugs into the side of your portable transmitter or receiver.

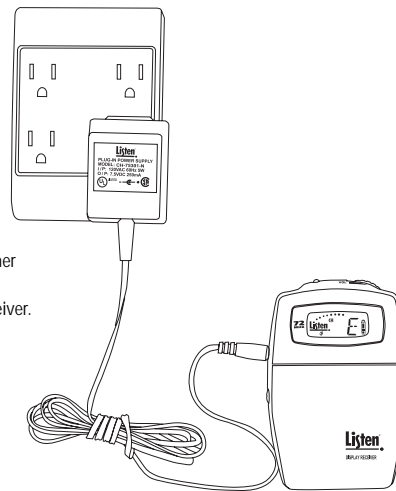

User's Manual

LR-300 Receiver

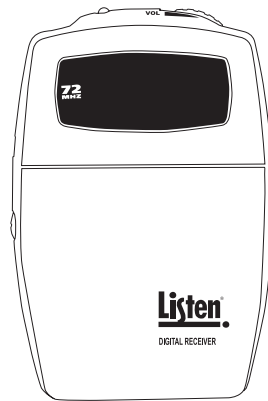

Don't miss a single sound. Listen.

Listen[®]

www.ListenTech.com

Listen Technologies Corporation
8535 South 700 West, Suite A
Sandy, Utah 84070-2515 USA
Telephone: +1.801.233.8992
Toll Free (North America): 1.800.330.0891
Fax: +1.801.233.8995
E-mail: info@ListenTech.com

LR-300 Package Contents

- LR-300-072 (72MHz)
- Warranty Card
- Receiver User Manual

Listen Part Number

72 MHz: LR-300-072



Optional Accessories

See pages 70-71.

LR-300 Table of Contents

Architectural Specifications44
 Specifications44
 Quick Reference46
 Setup Instructions48
 Operation Instructions50
 Charging Batteries52
 Wall Transformer Operation54
Supplementary Information55
 Channel Selection56
 Listen SQ™58
 RF Reception Maximization Strategies59
 72 MHz Frequency Compatibility Table60
 216 MHz Frequency Compatibility Table62
 Troubleshooting64
 Compliance Notice67
 FCC Statement68
 Warranty69
 Optional Accessories70

LR-300 Specifications

Architectural Specifications

The FM receiver shall be capable of receiving on 17 wide band channels and have a SNR of 80dB or greater. The receiver shall be capable of seeking channels. The device shall have a squelch. The device shall have an audio frequency response of 63Hz to 15KHz, ± 3 dB at 72MHz. The device shall incorporate a stereo headset jack that allows the user to plug in either a mono or stereo headset and listen to audio normally. The receiver shall incorporate automatic battery charging circuitry for recharging of NiMH batteries. The Listen LR-300 is specified.

Specifications

Specification		LR-300-072
RF	RF Frequency Range	72.025 - 75.950 MHz
	Number of Channels	17 (wide band)
	Sensitivity	.6uV typical, 1 uV maximum for 12dB SINAD
	Frequency Accuracy	$\pm .005\%$ stability 0° to 50°C (32° to 122° F)
	Antenna	Uses earphone cable
	Antenna Connector	3.5mm connector
	Squelch	Automatic on loss of RF signal
Compliance	FCC Part 15, Industry Canada	
** All system specifications are wireless end-to-end		
Audio	System Frequency Response	63Hz - 15kHz (± 3 dB)
	System Signal to Noise Ratio (A-weighted)	SQ enabled: 80dB; SQ disabled 60dB
	System Distortion	<2% total harmonic distortion (THD) at 80% deviation
	Output	3.5mm connectors, unbalanced, 0dBu nominal output level, 16mW maximum, impedance 32 Ohms
Controls	Set Up Controls	Alkaline/NiMH batteries, SQ enable/disable
	User Controls	Volume, SEEK (Channel SEEK is electronically lockable)
	Programming	Channel selection can be locked by holding the SEEK button for 5 seconds.

LR-300 Specifications continued

Specification		LR-300-072
Indicators	LED	Red, illuminates when unit is on. Flashes when batteries are low. Flashes when charging. Flashes when locked and user attempts to seek to another channel.
Power	Battery Type	Two AA batteries, alkaline or NiMH
	Battery Life (Listen batteries)	30 hours alkaline (LA-361), 15 hours NiMH rechargeable (LA-362)
	Battery Charging (NiMH only)	Fully automatic, 14 hours
	Power Supply Connector	2.3mm OD by 0.7mm ID, barrel type connector, 7.5VDC, center positive <250mA. Drop in contact points for use with Listen charging cases.
	Compliance	UL Listed
Physical	Dimensions	3.0 in x 1.0 in x 5 in WxDxH (7.6cm x 2.5cm x 13.cm)
	Unit Weight	3.9oz (111g)
	Unit Weight with batteries	5.8 oz (164.4g)
	Shipping Weight	1.0 lbs (453.6kg)
	Door	Manually lockable. SEEK behind the door.
Environmental	Temperature - Operation	-10° to 40°C (14° to 104° F)
	Temperature - Storage	-20° to 50°C (-4° to 122° F)
	Humidity	0 to 95% relative humidity, non-condensing

Quick Reference
LR-300 Front

3.5mm Input Jack
A Listen earpiece or headset
connects here.

LED - when lit, indicates
unit has power.

ON/OFF & VOLUME CONTROL dial



Quick Reference

LR-300 Inside Access Door

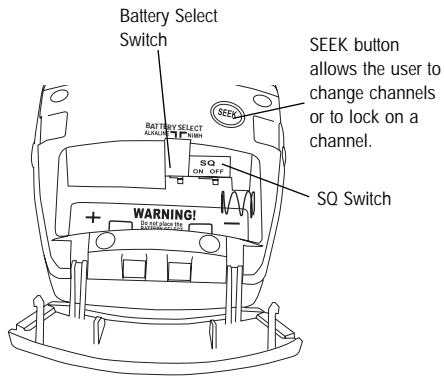

Battery Select Switch - place in NiMH position ONLY if you are using Nickel Metal Hydride batteries, otherwise, leave it in the Alkaline position.

SQ Switch: shipped in the ON position, use a screwdriver or pen to slide to the OFF position if needed. You should turn SQ off if any of your receivers do not have SQ.

LR-300 Top of Unit

LED indicators

- Steady Red: Normal operation
- Slow Flashing: Battery is low
- Slow Flashing while charging: Unit is charging

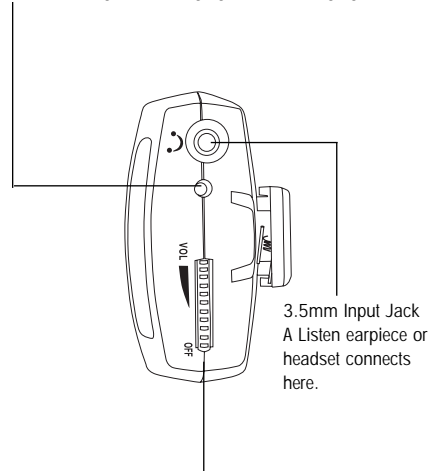

ON/OFF and VOLUME control dial - rotate the dial counter-clockwise to turn unit on and increase volume.

LR-300 Setup Instructions

1 Remove the product

Remove outer packaging and plastic cover. Inspect for physical damage. If damage is apparent, please contact Listen Technologies Corporation technical support for assistance. See page 69 for contact information.

2 Open the front access door

If locked, use a pocketknife or small screwdriver to unlock the door locks on both sides of the unit. To unlock the door, rotate the lock $\frac{1}{4}$ turn counterclockwise.

Grip the two tabs with your thumb and index finger and pull the door downward. Do NOT place batteries in the unit yet.

3 Select Battery Type

See diagram on page 47. You have two choices: NiMH and Alkaline. The unit is shipped with the switch in the Alkaline position. Use a pen or small screwdriver to select the battery type.

CAUTION: If you are using any battery type other than rechargeable Nickel Metal Hydride (NiMH) batteries, make sure the BATTERY selection switch is in the alkaline position.

4 Set SQ switch

The SQ switch is inside the battery compartment next to the Battery Select switch. The unit is shipped with SQ in the ON position. To turn it off, use a small screwdriver or pen to slide the switch to the OFF position (to the right). See page 58 for more information on SQ.

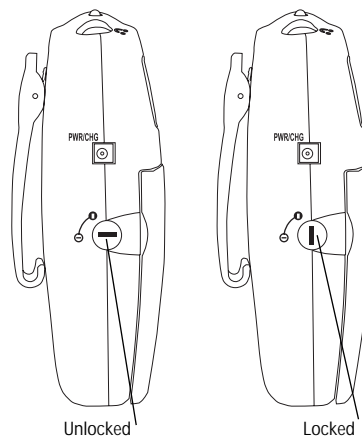

LR-300 Setup Instructions continued

4 Place Batteries in Unit

Place two AA batteries in the compartment, making note of the battery polarity shown in the battery compartment, and again verifying that the BATTERY SELECT switch is in the correct position for the batteries you are using. (ALK should be selected for all battery types other than NiMH).

NOTE: Listen uses 1800mAh (milli-Amp-hour) constant current NiMH (Nickel Metal Hydride) batteries. These may be purchased from your Listen dealer (ask for part number LA-362).

5 Connect an Earphone or Headset

Your headset or earphone will connect to the jack on the top of the unit. Either mono or stereo connectors may be used with a Listen receiver. Make certain you push the plug all the way into the jack.

6 Turn the Unit On

Receivers are turned on by rotating the volume dial counterclockwise. The red LED on top of the unit should activate and the LCD display should illuminate. If they do not, make sure you have installed the batteries correctly and that you are using fully charged batteries.

LR-300 Operation Instructions

1 Make Sure the Unit is On

Rotate the volume knob counterclockwise with an earphone or headset connected to the unit. Listen receivers use the cable of the earphone or headset as a receiving antenna.

Be careful when turning the unit on - if you turn the knob too far you might get too much volume in your earphone!

2 Find an audio transmission using SEEK

To find a channel on the LR-300 use the SEEK button. When you do this, the Listen receiver looks for the next active channel. Sometimes the unit will mistake interference for a real broadcast signal. If you get interference, press the SEEK button again. The unit may stop on a channel that is close to the actual broadcast channel, in which case the channel will sound noisy or distorted. Simply press SEEK again until you find the clearest operating channel.

3 Test the audio

If a transmitter is broadcasting on that channel, you will be able to hear the audio. If the signal is too weak, the audio will be muted (squelched).

4 Adjust the volume control

Use the control dial on the top of the unit to adjust the volume to a comfortable level.

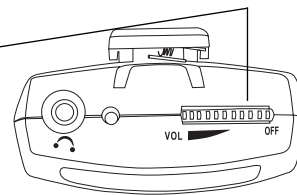

LR-300 Operation Instructions continued

5 To Lock into Only One Channel

Press and hold the SEEK button for 5 seconds to lock a receiver onto the currently tuned channel. Press and hold the button again to unlock. When locked the LED on top of the unit will flash when you press the SEEK button.

Is the Channel Locked on My Receiver?

On the LR-300, when the channel is locked the red LED on the top of the unit will flash when you press the SEEK button.

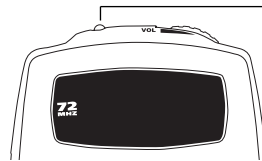

If locked, LED flashes on all portable receivers when SEEK button is pressed.

LR-300 Charging Batteries

The LR-300 and all Listen receivers are unique because they have SmartCharge™ chargers built in. When any of these units are connected to an LA-202 wall transformer or dropped into a Listen charging case, NiMH batteries will be charged.

To charge the batteries using the LA-202 wall transformer, plug the transformer into the jack marked "PWR/CHG" on the side of the unit. The unit can be operated while the batteries are charging.

To charge the batteries using a drop-in charger, simply place the unit into a slot in the charger and connect the charger to power. Make sure the unit is fully seated in its slot.

One of several charging cases available from Listen. Check the Listen website for more details.

SmartCharge™ uses a pulse charging, which greatly extends the life of Nickel Metal Hydride (NiMH) batteries. The entire charging process takes 13 hours. Listen recommends that you allow the charger to complete its full cycle every time for maximum battery life.

Connect LA-202 here and plug it into an AC wall outlet.

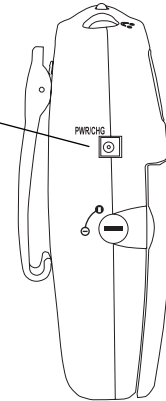

IMPORTANT: DO NOT ATTEMPT TO CHARGE ANY TYPE OF BATTERY OTHER THAN NiMH (NICKEL METAL HYDRIDE) with your Listen equipment. Alkaline batteries may explode when connected to a charger. Other risks of charging non-NiMH batteries include destruction of property or fire.

IMPORTANT: In order to charge NiMH batteries, the BATTERY SELECT switch in your Listen product must be set to the NiMH setting. Use a pen or small screwdriver to move the switch (located in the battery compartment) to the proper position.

LR-300 Charging Batteries continued

During the charge cycle, the red LED on top of the Listen product will flash slowly. When charging is completed, the LED will turn off. It is not necessary to unplug the charger; however, if you unplug the unit from the charger and then plug it back in, it will begin the 13-hour charge cycle over again.

When not using the LR-300, it is recommended to leave the unit on the charger. The charger provides a "maintenance" charge that keeps the battery at 100%. If the unit is not on the charger, the battery will lose up to 20% of its charge per month.

NOTE: Listen uses 1800mAh (milli-Amp-hour) constant current NiMH (Nickel Metal Hydride) batteries. These may be purchased from your Listen dealer (ask for part number LA-362).

One of several charging cases available from Listen. See the www.ListenTech.com for more options.

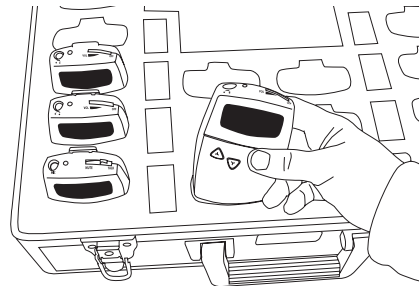

LA-311 - 16-unit Drop In Charging Case shown

LR-300 Wall Transformer Operation

The LR-300 will operate normally when connected to a wall transformer. Use Listen part number LA-202, available from any Listen dealer. Connect the wall transformer to the jack on the side of the LR-300 marked "PWR/CHG" and plug the wall transformer into a grounded AC outlet.

You do not need to have batteries installed in the LR-300 to operate it with a wall transformer.

NOTE: If batteries are in the unit ensure that the battery selection switch is set properly as shown on page 47. Please review the information on page 52 for important information regarding battery type and charging.

The LA-202 wall transformer plugs into the side of your portable transmitter or receiver.

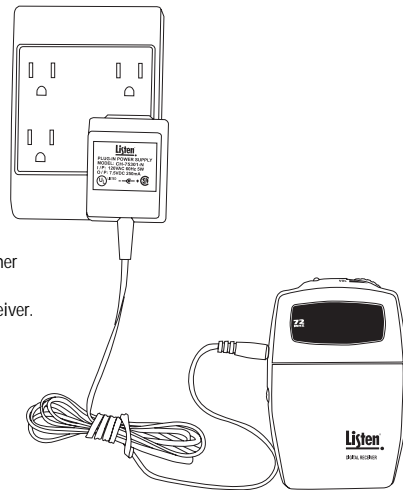

Supplementary Information

Channel Selection56
Listen SQ™58
RF Reception Maximization Strategies59
72 MHz Frequency Compatibility Table60
216 MHz Frequency Compatibility Table62
Troubleshooting64
Compliance Notice67
FCC Statement68
Warranty69
Optional Accessories70

Channel Selection

It is highly recommended that after channel selection has been achieved, you lock the channel so that it cannot be changed by the user. To accomplish lock on receivers, press and hold seek for 5 seconds. Repeat the process to unlock. It is important to choose channels that are free from interference to achieve proper operation of your Listen equipment. This process is trial and error. Before turning on the transmitter, listen to the wide band channels (lettered channels at 72MHz and channels that start with a "2" for 216MHz). Listen to the audio through the headphone or via the speaker. Choose a channel with the least amount of interface. Unless you are interfacing with an existing narrowband transmission system, always use a wide band channel. If you are using multiple channels follow this process:

- a. **Same Space** If you are using transmitters in the same space, the most number of channels that will work simultaneously is six at 72MHz and three at 216MHz. With all of the transmitters off, listen for interference on all the wide band channels via the headphone jack. Using the frequency compatibility tables on pages 60-63, eliminate any channels that have noticeable interference. Now choose the channels with the widest channel spacing. It is recommended that adjacent channels be spaced at least 300KHz. If there is no interference the following channels are recommended: A, C, E, I, J, and H for 72MHz and channels 2A, 2K and 2V at 216MHz.
- b. **Distributed Spacing** If you are using transmitters that are spread out over space, you can achieve more simultaneous broadcast channels. However, it is critical that your receiver(s) be located as close to its transmitter as possible. You can use adjacent channels (see frequency compatibility tables on pages 60-63) in this case as long as the adjacent channel transmitter is at least 50% further away from the receiver as its transmitter. Example: The transmitter for the receiver on channel E is 100 feet from the receiver. The adjacent channel transmitter on channel D should be at least 150 feet away.

Channel Selection continued

Notes in regard to using 72MHz and 216MHz systems

- i. 72MHz in a secondary frequency band. This means that other transmitters are licensed to use these frequencies. Thus, you may experience interference from paging transmitters and other type transmissions. You will need to find a clear channel by listening to all the wide band channels.
- ii. 216MHz is a primary frequency band and no other types of transmissions are authorized to use it. Thus, you will find the highest probability of clear channels in this band. However, you may experience intermodulation of the TV Channel 13 aural carrier if there is a channel 13 transmitter in your area and you are close to the transmitter. If you cannot find a clear channel in 216MHz band due to channel 13, it is recommended that you switch to a 72MHz system.

NOTE: The LR-300-072 can only be used with the 17 wide band 72MHz channels, if you are using the LR-300 choose only lettered wide band frequencies on your transmitter.

Listen SQ™

We are accustomed to listening to low noise, high fidelity audio (delivered via CD, DVD, etc.). FM radio systems, such as those made by Listen, have more inherent noise compared to most sound systems. To reduce noise of our systems, Listen now offers a noise reduction technology called ListenSQ™. Both the transmitter and receiver must have SQ on to achieve the desired results. SQ is now available on new Listen systems, including the system you received in this shipment. If you are planning to use this product with older Listen systems or equipment not manufactured by Listen, you should disable SQ.

Your Listen equipment has been shipped to you with the SQ feature enabled. You may need to disable the SQ function for one or more of the following reasons:

1. You are using your new Listen system with older version Listen equipment that does not have the SQ function.
2. You are using your new Listen system with equipment supplied by other manufacturers.
3. You expect that end users may bring and use their own receivers that don't have the SQ function.

SQ Summary

- Improves noise performance by at least 20dB
- SQ is NOT compatible with older version Listen products
- SQ is NOT compatible with other manufacturers' products
- SQ is NOT squelch
- To work properly, SQ must be enabled for both the transmitter and receivers
- SQ can be disabled to permit operation with older Listen products or other manufacturers' products

RF Reception Maximization Strategies

For proper and dependable operation, Listen receivers should receive a strong and consistent signal from the originating transmitter. The following strategies should be used maximize this signal:

- a. When designing and installing your system, keep in mind that the location of both the transmitter and receivers is critical to maximizing signal strength.
- b. Eliminate or minimize obstructions between the transmitter and receivers.
- c. Minimize the distance between the transmitter and receivers.
- d. Move transmitter and receivers away from metal objects.
- e. Place the transmitting antenna as high as possible (on stationary transmitters).
- f. Orient both transmitting and receiving antennas vertically.
- g. For 216MHz stationary LT-800 transmitter only, consider using a gain antenna such as a Yagi type antenna or the LA-107 ground plane antenna.
- h. On portable transmitters and receivers, the cable from the microphone or headset is the antenna; ensure that the cable is not coiled or laying horizontal.

CAUTION: When installing remote antennas, ensure the antenna is clear of power lines.

NOTE: If the RF signal to the 216MHz models is too high, the audio will be distorted. This may happen if you are within 40 feet (12m) of the LT-800-216 transmitter or within 5 feet (1.5m) of the LT-700-216 transmitter.

Coaxial cable, connectors, and optional antenna mounting kits are available from Listen. Visit www.ListenTech.com or ask your dealer for details.

72MHz Compatibility Chart

Updated 03.16.04

Frequency MHz	Phonic							
	Listen	Ear	Comtek	Phonak	Williams*	Gentner	Telex	Drake
72.0250	1	1	1	A1	(11, 1)			
72.0500					(2)	1		
72.0750	2	2	2	A2	(12, 3)			
72.1000	A	A	A	A	A, (13, 4)	2	A	72.1
72.1250	3	3	3	A3	(14, 5)			
72.1500					(6)	3		
72.1750	4	4	4	A4	(15, 7)			
72.2000	K	K	K	K	K, (8)	4	B	72.2
72.2250	5	5	5	K5	(16, 9)			
72.2500					(10)	5		
72.2750	6	6	6	K6	(17, 11)			
72.3000	B	B	B	B	B, (18, 12)	6	C	72.3
72.3250	7	7	7	B7	(19, 13)			
72.3500					(14)	7		
72.3750	8	8	8	B8	(20, 15)			
72.4000	N	N	N	N	N, (16)	8	D	72.4
72.4250	9	9	9	N9	(21, 17)			
72.4500					(18)	9		
72.4750	10	10	10	N0	(22, 19)			
72.5000	C	C	C	C	C, (23, 20)	10	E	72.5
72.5250	11	11	11	C1	(24, 21)			
72.5500					(22)	11		
72.5750	12	12	12	C2	(25, 33)			
72.6000	O	O	O	O	O, (24)	12	F	72.6
72.6250	13	13	13	O2	(26, 25)			
72.6500					(26)	13		
72.6750	14	14	14	4	(27)			
72.7000	D	D	D	D	D, (28)	14	G	72.7
72.7250	15	15	15	D5	(29)			

*Parenthesis indicate T35 and T20 narrowband.

NOTE: Wideband frequencies in highlighted rows.

Chart continued on next page

72MHz Compatibility Chart continued

Frequency MHz	Listen	Phonic Ear	Comtek	Phonak	Williams*	Gentner	Telex	Drake
75.5250	23	23	23	F3	(49, 59)			
75.5500					(60)	29		
75.5750	24	24	24	F4	(50, 61)			
75.6000	S	S	S	S	S, (62)	30	K	75.6
75.6250	25	25	25	S5	(51, 63)			
75.6500					(64)	31		
75.6750	26	26	26	S6	(52, 65)			
75.7000	G	G	G	G	G, (53, 66)	32	L	75.7
75.7250	27	27	27	G7	(54, 67)			
75.7500					(68)	33		
75.7750	28	28	28	G8	(55, 69)			
75.8000	T	T	T	T	T, (70)	34	M	75.8
75.8250	29	29	29	T9	(56, 71)			
75.8500					(72)	35		
75.8750	30	30	30	T0	(57, 73)			
75.9000	H	H	H	H	H, (58, 74)	36	N	75.9
75.9250	31	31	31	H1	(59, 75)			
75.9500					(76)	37		
75.9750	32	32	32	H2	(60, 77)			

*Parenthesis indicate T35 and T20 narrowband.

NOTE: Wideband frequencies in highlighted rows.

216MHz Compatibility Chart

Updated 03.16.04

Frequency MHz	Listen	Phonic Ear	Comtek	Phonak	Williams	Gentner	CSI	AVR	Light Speed
216.0125	1A		1	1				C01	N01
216.0250	2A	41	41	41		1	1		
216.0375	3A		2	2					
216.0625	1B		3	21					
216.0750	2B	42	42	42		2	10		
216.0875	3B		4	4					
216.1125	1C		5	5				C05	
216.1250	2C	43	43	43	A	3	6		
216.1375	3C		6	22					
216.1625	1D		7	23					
216.1750	2D	44	44	44	B	4	14		
216.1875	3D		8	8					
216.2125	1E		9	9				C09	N09
216.2250	2E	45	45	45	C	5	2		
216.2375	3E		10	24					
216.2625	1F		11	25					
216.2750	2F	46	46	46	D	6	11		
216.2875	3F		12	12				C12	N12
216.3125	1G		13	13					
216.3250	2G	47	47	47	E	7	7		
216.3375	3G		14	26					
216.3625	1H		15	27					
216.3750	2H	48	48	48	F	8	15		
216.3875	3H		16	16				C18	N18
216.4125	1J		17	17				C21	
216.4250	2J	49	49	49	G	9	18		
216.4375	3J		18	18					
216.5125	1K		21	61					
216.5250	2K	51	51	29	H	10	3		

*Parenthesis indicate T35 and T20 narrowband.

NOTE: Wideband frequencies in highlighted rows.

Chart continued on next page

216MHz Compatibility Chart continued

Frequency MHz	Listen	Phonic Ear	Comtek	Phonak	Williams	Gentner	CSI	AVR	Light Speed
216.5125	1K		21	61					
216.5250	2K	51	51	29	H	10	3		
216.5375	3K		22	62					
216.5625	1L		23	28					
216.5750	2L	52	52	52	I	11	12		
216.5875	3L		24	64				C24	N64
216.6125	1M		25	65				C25	
216.6250	2M	53	53	53	J	12	8		
216.6375	3M		26	81					
216.6625	1N		27	82					
216.6750	2N	54	54	54	K	13	16		
216.6875	3N		28	68					
216.7125	1P		29	69				C29	
216.7250	2P	55	55	55	L	14	19		
216.7375	3P		30	83					
216.7625	1R		31	84					
216.7750	2R	56	56	56		15	4		
216.7875	3R		32	72				C32	N72
216.8125	1S		33	73				C33	
216.8250	2S	57	57	57			13		
216.8375	3S		34	76					
216.8625	1T		35	85					
216.8750	2T	58	58	58			9		
216.8875	3T		36	86					
216.9125	1U		37	77				C37	N77
216.9250	2U	59	59	59			17		
216.9375	3U		38	88					
216.9625	1V		39	79				C39	
216.9750	2V	60	60	60			5		
216.9875	3V		40	80				C40	N80

*Parenthesis indicate T35 and T20 narrowband.

NOTE: Wideband frequencies in highlighted rows.

Receiver Troubleshooting - LR-300, LR-400, LR-500

The receiver has no power.

Make sure the unit has either fully charged batteries or a Listen approved wall transformer connected. Make sure the VOLUME knob has been rotated to the ON position. If this does not work, try a different set of batteries. Make sure the batteries are installed properly.

There is no audio.

Make sure you have turned the volume control up. Make sure the earphone is plugged all the way into the jack on the top of the unit. Make sure the transmitter is broadcasting an audio source. Make sure you're tuned to the same channel as the transmitter (see page 56). If the RF signal is too weak, the receiver will squelch and mute the audio source; move closer to the antenna or make sure the transmitter's output RF power switch is set on "FULL" (LT-800).

The audio is distorted.

Make sure you're receiving on the correct channel. Make sure the audio on the transmitter is not turned up too loud; this will cause distortion. Make sure the earphone connector is pushed all the way into the jack on top of the unit. If you're using the LR-300, re-scan the channels to find the clearest channel (see page 50). Make sure the SQ switch on your transmitter and receivers is turned ON (or OFF, if some of your equipment is not SQ capable). Make sure you are not too close to the transmitting antenna. If you can't get farther away from the antenna, turn down the RF output power on the stationary (LT-800) transmitter.

There is interference.

Try different frequencies on the transmitter and receivers until you find a clear channel. If this does not work, try a different frequency band (i.e. if you are using 72MHz, try 216MHz or vice versa). This is accomplished by returning the equipment to Listen (at no charge). Please contact Listen technical support for assistance (see page 69 for information).

Receiver Troubleshooting continued

I cannot pick up the signal on the receiver.

Check to make sure the receiver and the transmitter are on the same frequency and channel. Also make sure the receiver is in broadcast range of the transmitter.

I can pick up the signal on the receiver, but it sounds like it's not tuned in.

Check to make sure the transmitter and receiver are on exactly the same channel number/letter. If you're using the LR-300, re-scan the channels to find the clearest channel by pressing SEEK (see page 50).

I'm using another brand of transmitter - how do I tell which channel to use?

Refer to Listen's Frequency Compatibility Tables (pages 60-63). Either adjust the transmitter or the receiver to a common channel.

There is not sufficient range.

Make sure you are located as close as possible to the antenna of the transmitter. Try to place the antenna as high as possible and free from obstacles. You can also check the squelch setting; perhaps it is too sensitive. To change this setting, refer page 17 (LR-500) or to page 36 (LR-400).

Users keep changing channels.

You can prevent users from changing channels by locking in the channel selection. This is done by pressing and holding the SEEK button for 5 seconds. When the channel is locked, the padlock icon will appear on the LR-400 and LR-500 displays. On the LR-300, the LED will flash when the channel is locked and seek is pressed. In addition, you can lock the access doors to the units.

Receiver Troubleshooting continued

I cannot change channels when pressing the UP and DOWN buttons or the SEEK button.

The unit is locked. Press the SEEK button for 5 seconds to unlock.

When I change channels, only certain channels are accessible.

The unit has been programmed to tune to only certain channels (LR-500 only). You can change these channel lock-out selections by re-programming the unit (see page 16).

My batteries are not charging.

Make sure the battery switch is in the NiMH setting and that you are using NiMH (Nickel Metal Hydride) batteries. Make sure you are using only a Listen supplied charging unit or transformer. Never try to charge alkaline or NICAD batteries.

I want to run the unit from a wall transformer.

Simply plug a Listen approved transformer (LA-202) to the CHG/PWR connector on the side of the unit. Batteries do not need to be installed when operating the unit with a wall transformer; however, if you have NiMH batteries installed and the BATTERY select switch is set to NiMH, the batteries will charge while the unit is being used.

It's confusing for users to have 57 choices when switching between channels.

Use the programming feature (only available in the LR-500) to limit the number of channels accessible by users.

Compliance Notice

This device complies with part 15 of the FCC Rules. Operation is subject to the following two conditions: (1) These devices may not cause harmful interference, and (2) these devices must accept any interference received, including interference that may cause undesirable operation.

FCC Statement

This equipment has been tested and found to comply with the limits for a class B digital device, pursuant to part 15 of the FCC Rules. These limits are designed to provide reasonable protection against harmful interference in a residential installation. This equipment generates, uses and can radiate radio frequency energy and if not installed and used in accordance with the instructions, may cause harmful interference to radio communications. However, there is no guarantee that interference will not occur in a particular installation. If this equipment does cause harmful interference to radio or television reception, which can be determined by turning the equipment off and on, the user is encouraged to try to correct the interference by one or more of the following measures:

- Reorient or relocate the receiving antenna.
- Increase the separation between the equipment and receiver.
- Connect the equipment into an outlet on a circuit different from that to which the receiver is connected.
- Consult the dealer or an experienced radio/TV technician for help.

This equipment has been certified to comply with the limits for a class B computing device, pursuant to FCC and IC Rules. In order to maintain compliance with FCC and IC regulations, shielded cables must be used with this equipment. Operation with non-approved equipment or unshielded cables is likely to result in interference to radio and TV reception. The user is cautioned that changes and modifications made to the equipment without the approval of manufacturer could void the user's authority to operate this equipment.

Warranty

Listen Technologies Corporation (Listen) warrants its receivers (LR-300, LR-400, LR-500) to be free from defects in workmanship and material under normal use and conditions for the useful lifetime of the product from date of purchase. All other products and accessories are warranted for ninety days from date of purchase. This warranty is only available to the original end purchaser of the product and cannot be transferred. Warranty is only valid if warranty card has been returned within 90 days of purchase. This warranty is void if damage occurred because of misuse or if the product has been repaired or modified by anyone other than a factory authorized service technician. Warranty does not cover normal wear and tear on the product or any other physical damage unless the damage was the result of a manufacturing defect. Listen is not liable for consequential damages due to any failure of equipment to perform as intended. Listen shall bear no responsibility or obligation with respect to the manner of use of any equipment sold by it. Listen specifically disclaims and negates any warranty of merchantability or fitness of use of such equipment including, without limitation, any warranty that the use of such equipment for any purpose will comply with applicable laws and regulations. The terms of the warranty are governed by the laws of the state of Utah, USA. Listen will only accept returned products with prepaid shipping and with a return authorization number. To receive a return authorization number call 1.800.330.0891 or +1.801.233.8992. Please see www.ListenTech.com or contact Listen for complete warranty details.

Optional Accessories Earphone Options



Ear Speaker
LA-164



Ear Speaker
LA-161



Dual Ear Speaker
LA-162



Stereo Headset
LA-165



Neckloop
LA-166

Optional Accessories

Connector Options



**Consumer
Camcorder Cable**

LA-265



Sacrificial Cable

LA-275



**Professional
Camcorder Cable**

LA-266

Listen[®]

www.ListenTech.com

Listen Technologies Corporation
8535 South 700 West, Suite A
Sandy, Utah 84070-2515 USA
Telephone: +1.801.233.8992
Toll Free (North America): 1.800.330.0891
Fax: +1.801.233.8995
E-mail: info@ListenTech.com