

THE HOTTEST NAME IN HEATING

# FIRECHARM LF ELECTRONIC

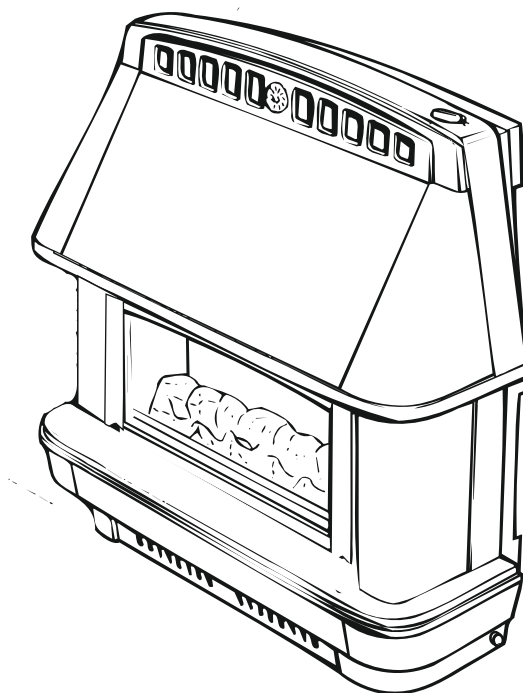

## RADIANT/CONVECTOR GAS FIRE

BRONZE (G.C. No. 32 689 32)

BLACK (G.C. No. 32 689 33)

## Users Operating Instructions

**THIS APPLIANCE IS FOR USE WITH NATURAL GAS ONLY  
IT MUST NOT BE USED WITH ANY OTHER TYPE OF GAS**

**THIS APPLIANCE IS A DOMESTIC ROOM HEATER  
IT MUST NOT BE USED FOR ANY OTHER PURPOSE**

***THIS LEAFLET IS INTENDED TO HELP YOU UNDERSTAND AND USE YOUR NEW FIRE EFFICIENTLY.  
PLEASE READ THESE INSTRUCTIONS BEFORE USING THE FIRE AND KEEP FOR FUTURE REFERENCE.***

## IMPORTANT NOTES

1. This fire is for use on Natural Gas only and cannot be used on any other gas. "CE marked" for use in the United Kingdom and Eire.
2. This fire must be installed and serviced regularly in accordance with the current Gas Safety (Installation and Use) Regulations by a competent person i.e. Gas Safe registered Engineer. Where solid fuel has been used the chimney must be swept before installation. The fire must be installed in accordance with the installation instructions, and the rules in force.
3. It is recommended that at least once a year the appliance should be removed to check the catchment space and the chimney for debris by a Gas Safe registered Engineer. The fire should be checked annually to ensure continued clearance of products and that there is no excessive build up of powdery substances.
4. DRESSGUARD: The glass window on this appliance conforms to the requirements of BS 1945 : 1991 and satisfies the heating Appliances (Fireguards) Regulations 1991.  
IT DOES NOT GIVE FULL PROTECTION FOR YOUNG CHILDREN, THE ELDERLY OR THE INFIRM!  
**A fireguard conforming to B.S. 8423 (Fireguards for heating appliances for domestic use) should be used for the protection of children, the elderly or the infirm. Such a guard is also recommended for pet animals.**  
WARNING: The glass panel is of a special heat resisting type and if damaged the glass window must be replaced with the proper spare (G.C. No. 159 674) DO NOT USE THE FIRE WITH DAMAGED GLASS.
5. After the fire has been installed you may wish to fix a shelf above. This is quite acceptable provided the underside of a combustible shelf is at least 150mm above the fire and does not project more than 150mm forward. For a deeper shelf allow 13mm increase in shelf height for every 25mm increase in depth.
6. Do not burn paper or any rubbish in the fire.
7. Clothes etc. must not be draped over the fire. The convection outlet must never be obstructed by hanging towels etc.
8. When the fire is first used some slight smoke and smell may be given off but this will clear after a few hours of use at the full on rate (Setting No. 4). Condensation on the window inner surface is normal, when the heater is lit from cold.
9. IMPORTANT: When considering fitting any heating appliance or wallpapering a room in which one is fitted if blown vinyl or heat sensitive wallpapers (or soft furnishings) are used in the vicinity of the heat source then they may become heat damaged or discoloured especially just above the fire.
10. It is important for safe operation and to maintain efficiency that the fire is not operated with a damaged or broken coal bed. IMPORTANT: Under no circumstances should any loose coals be purchased and used on the coal bed. The fire has a specially designed coal bed and only this must be used.
11. This product uses fuel effect pieces containing Refractory Ceramic Fibre (RCF), which are man-made vitreous silicate fibres. Excessive exposure to these materials may cause temporary irritation to eyes, skin and respiratory tract, consequently, it makes sense to take care when handling these articles to ensure that the release of dust is kept to a minimum.

## TO LIGHT AND OPERATE

WARNING: If the flames are found to be extinguished and the control knob is not in the OFF position, the control knob must be turned to the OFF position and no attempt should be made to light the fire for 3 minutes.

NOTE: The control knob is situated on the top right hand side of the fire and is marked with the symbols OFF,  $\overline{\text{f}}$ , 1, 2, 3, 4. The ignition spark generator, battery powered (size AA), is located at the lower rear RH side.

### LIGHT THE FIRE

Depress the control knob and turn it anticlockwise to the  $\overline{\text{f}}$ (pilot) position. Depress the control knob, sparks will be heard and the pilot should light which can be seen in the lower centre of the glass window on the fire. If the pilot did not light turn the control knob to OFF and try again. When the pilot has lit keep the knob depressed for a further 10 seconds to activate the flame supervision device otherwise the pilot will go out again. Once the pilot is established turn the control knob to the desired setting.

**The control knob is connected to the gas tap by a universal coupling and will have a 'loose feel' to it, which should not cause concern.**

- |                   |   |  |
|-------------------|---|--|
| CONTROL SETTING 1 | - | the centre burner section is on at a low rate.                                   |
| CONTROL SETTING 2 | - | the centre burner section is on at a high rate.                                  |
| CONTROL SETTING 3 | - | the centre burner is on high and the outer burner sections are on at a low rate. |
| CONTROL SETTING 4 | - | all burner sections are on full rate.  |

TO TURN OFF depress the control knob slightly and turn clockwise to the OFF position.

NOTE: If you want to relight a hot fire wait 5 minutes before doing so.

## LIGHTING WITH A TAPER

In the unlikely event of failure of the ignition you can light the fire with a taper or spill. First remove the glass door mask which surrounds the glass window by lifting it up slightly and pulling it forward bottom first. Now remove the window as detailed below.

Light your taper or spill and depress and turn the control knob anticlockwise to the  $\overline{\pi}$  (pilot) position. Insert the lit taper over the central front hole of the coal bed (inside the glass). Keep the control knob depressed for ten seconds after the pilot has lit to activate the flame supervision device. Replace the window and glass door mask, before turning the fire to any other setting.

### SAFETY DEVICE

The fire is fitted with a flame supervision and Oxygen depletion device. This will shut the fire off if the pilot goes out for any reason. This may be caused by the Oxygen level in the room falling below a prescribed level due to poor flue pull etc. If the fire keeps going out you must have it checked by a competent person (i.e. A Gas Safe registered Engineer).

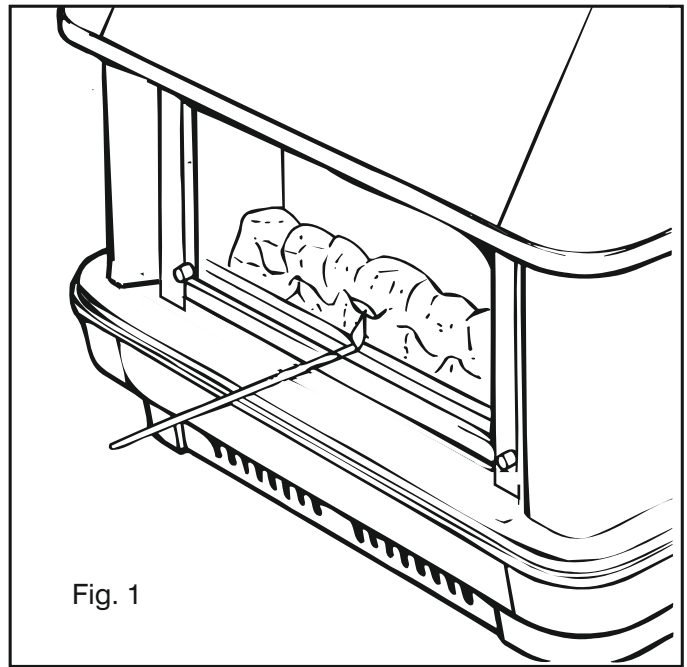

Fig. 1

## CLEANING AND SIMPLE MAINTENANCE

Generally the fire will only need dusting. Any painted surface or metal part should be cleaned with a damp cloth only. Never use abrasive cleaners on painted surfaces or metal parts. Any stains on the glass window can be removed with a non abrasive cleaner (such as hob cleaner) or with any brand of plastic scourer after removing the window. Should any soot accumulation become excessive, the fuel effect pieces should be removed from the fire for cleaning. Cleaning should be carried out in a well-ventilated area or in the open air, by gently brushing with the pieces held away from your face so that you avoid inhaling the dust. We do not recommend the use of a normal domestic vacuum cleaner, which may blow dust back into the air.

Remove the window as follows:

- (a) Remove the glass door mask as detailed above.
- (b) Remove the 2 domed nuts securing the glass window.
- (c) Pull the window forward at the bottom to clear the studs then downward and outward to clear the top clip.

After cleaning the window replace it by first pushing it upward into the top clip then engaging the lower nuts and front panel.

IT IS IMPORTANT TO REGULARLY CLEAN THE GLASS AND REGULAR CLEANING UNDER THE FIRE WITH A VACUUM CLEANER IS STRONGLY RECOMMENDED.

It will not normally be necessary to remove the coal bed for cleaning but if this is done only use a soft brush to remove any powdery deposits from the coal bed. To replace the coal bed simply insert it into the firebox behind the raised metal front plate noting that the front of the coal bed has six smaller holes.

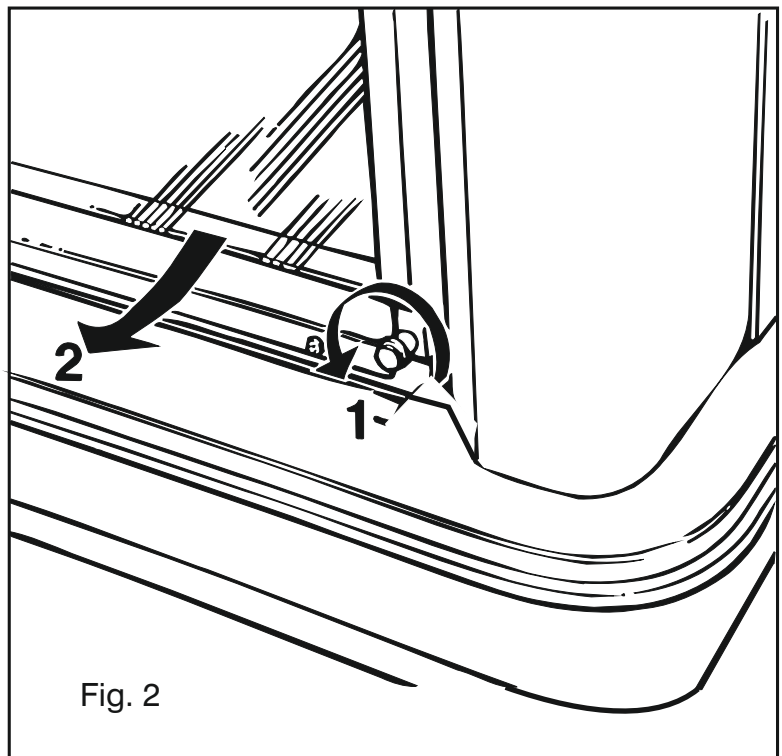

Fig. 2

## CHANGING THE BATTERY

Unscrew the cap, anti-clockwise, off the battery holder. Remove the battery, and replace with a new one. This should be inserted 'flat end first' - this is the negative terminal. Replace the cap carefully to avoid cross-threading it.

Please note: Consumable items, such as batteries, are not covered by the guarantee.

## SPARES AND SERVICE

For spares and service apply to your local supplier or installer stating that the appliance is a FIRECHARM LF ELECTRONIC, saying whether it is black or bronze in colour and quoting the serial number and the appliance G.C. number which are displayed on the lower right side of the fire.

ADVANTAGE SHOULD BE TAKEN OF REGULAR SERVICING/INSPECTION (e.g. ANNUALLY) FOR GAS APPLIANCES BY A 'GAS SAFE REGISTERED ENGINEER, TO ENSURE CONTINUED SAFE OPERATION.

Full on the fire consumes 5.6 units of gas per hour. The cost of a unit of gas varies according to the tariff. Please check with your local Gas Region. When installed in a typical chimney and based on the cost of gas at 2.5 pence per kW hour at setting number 4 using 5.57kW costs 14 pence per hour approximately, and at setting number 1 using 1.55kW costs 4 pence per hour approximately. The maximum output is 4.4kW, and the minimum output is 0.83kW.

If any "Home Improvements" are made to the dwelling in which a gas appliance is fitted, e.g. the fitting of an extractor fan, draught proofing or double glazing, then the air supply to and the flueing of the appliance must be re-checked by a competent person (i.e. A Gas Safe registered Engineer).

## PARTS REPLACEABLE BY USER

G.C. PART NUMBER	MAKERS PART NUMBER	DESCRIPTION
159 698	991762	Control Knob
159 674	992318	Coal Bed
	991860	Door Assembly

THE GAS CONSUMERS' COUNCIL (GCC) IS AN INDEPENDENT ORGANISATION WHICH PROTECTS THE INTEREST OF GAS USERS. IF YOU NEED ADVICE, YOU WILL FIND THE TELEPHONE NUMBER IN YOUR LOCAL TELEPHONE DIRECTORY UNDER GAS.



### Robinson Willey

GDC Group Ltd, Millbrook House, Grange Drive,  
Hedge End, Southampton, SO30 2DF.  
Telephone: 0844 879 35 88

E-mail: [info@robinsonwilley.co.uk](mailto:info@robinsonwilley.co.uk) website: [www.robinsonwilley.co.uk](http://www.robinsonwilley.co.uk)

**Robinson Willey is a Trading Division of the GDC Group Ltd**