



## **MP-25 User Manual**

- 60010120      ASSY, MP 25-SO - SINGLE PHASE 220V**
- 60010121      ASSY, MP 25-HO - 3 PHASE - 220V**
- 60010122      ASSY, MP 25-SO - 3 PHASE - 220V**

Revision 3 - – 08/01/2012

**620 County Road 4841, Haslet, TX 76052**

**Ph 817.636.5637    Fax 817.636.5675**

[www.machine-technologies.com](http://www.machine-technologies.com)

Dear Customer,

Before starting this machine please complete the following;

Machine Date of purchase.....

Machine serial number.....

Please read the following information contained within this manual and fully familiarize yourself with the equipment.

<b>Section 1 - General Safety information.....</b>	<b>5</b>
<b>Danger.....</b>	<b>5</b>
<b>Section 2 - Machine Description .....</b>	<b>6</b>
<b>Function.....</b>	<b>6</b>
<b>Machine illustrations.....</b>	<b>7</b>
<b>Photographs .....</b>	<b>7</b>
<b>Illustration – 60010120 ASSY, MP 25-SO - SINGLE PHASE 220V.....</b>	<b>8</b>
<b>Bill of Materials – 60010120 ASSY, MP 25-SO - SINGLE PHASE 220V .....</b>	<b>8</b>
<b>Bill of Materials – 60010120 ASSY, MP 25-SO - SINGLE PHASE 220V .....</b>	<b>9</b>
<b>Illustration – 60010121 ASSY, MP 25-HO - 3 PHASE - 220V.....</b>	<b>10</b>
<b>Bill of Materials – 60010121 ASSY, MP 25-HO - 3 PHASE - 220V .....</b>	<b>11</b>
<b>Photographs of.....</b>	<b>12</b>
<b>30000039 D8-1.5 STATOR-ADJ-GREEN-INTCLAMP .....</b>	<b>12</b>
<b>30000040 D8-1.5 ROTOR.....</b>	<b>12</b>
<b>30000041 D6-3 STATOR-FIXED-ORANGE .....</b>	<b>12</b>
<b>30000042 D6-3 ROTOR.....</b>	<b>12</b>
<b>30000043 D4-3 STATOR-FIXED-GREEN .....</b>	<b>13</b>
<b>30000044 D4-3 ROTOR.....</b>	<b>13</b>
<b>30000045 R8-1.5 STATOR-ADJ-BLACK-INTCLAMP\.....</b>	<b>13</b>
<b>30000046 R8-1.5 ROTOR.....</b>	<b>13</b>
<b>Pump adapters.....</b>	<b>14</b>
<b>44010257- ADAPTER,PUMP 90MM-MP-25.....</b>	<b>14</b>
<b>44010258 - ADAPTER,PUMP 113.5MM-MP-25.....</b>	<b>14</b>
<b>Water plate assemblies and water pump .....</b>	<b>15</b>
<b>60010136 ASSY,WATER CONTROL MP-25-4GPM.....</b>	<b>15</b>
<b>60010142 ASSY,WATER CONTROL MP-25-7GPM.....</b>	<b>16</b>
<b>60010210 ASSY,WATERPUMP, 1PH MP-25 HF - complete .....</b>	<b>17</b>
<b>Motor mount.....</b>	<b>18</b>
<b>60010134 ASSY,UPPER MTR MNT MP-25.....</b>	<b>18</b>
<b>Mixing shafts complete, and clean out shaft complete.....</b>	<b>19</b>
<b>60010125 ASSY, DRIVE/MIX SHAFT MP-25 SO.....</b>	<b>19</b>
<b>60010154 ASSY, DRIVE/MIX SHAFT MP-25 HO.....</b>	<b>19</b>
<b>60010126 ASSY, SHAFT CLEAN OUT-MP-25 .....</b>	<b>20</b>
<b>Water pressure tester, water hoses and fan duct .....</b>	<b>21</b>
<b>60010140 TESTER,WATER PRESS - 35MM-MALE-600PSI .....</b>	<b>21</b>
<b>60010139 ASSY WATER HOSE-COMPLETE-MP-25 .....</b>	<b>21</b>
<b>60010147 ASSY,PUMP HOSE COMPLETE MP-25 .....</b>	<b>22</b>
<b>60010144 ASSY,FAN DUCT MP-25 .....</b>	<b>23</b>
<b>60010148 ASSY,WASHDOWN HOSE COMPLETE MP-25.....</b>	<b>23</b>
<b>20000124 REMOTE, WIRED SPRAY GUN MNT-MP25 – option only ....</b>	<b>24</b>
<b>Electric Drive unit .....</b>	<b>25</b>
<b>Typical 3 PH layout – 7.5HP (5.5kW) shown .....</b>	<b>25</b>
<b>Cutaway view of Grease seal, Sumi seal, seal pusher, and grease tube .....</b>	<b>26</b>
<b>Alternate motor fitment and seal configuration. ....</b>	<b>27</b>
<b>Electronic Drive module – 20000046 / 47 .....</b>	<b>29</b>
<b>Function .....</b>	<b>29</b>
<b>Illustrations.....</b>	<b>31</b>

<b>Section 3 – Transportation and positioning.....</b>	<b>34</b>
<b>Section 4 – Machine set up .....</b>	<b>36</b>
<b>Unpacking.....</b>	<b>36</b>
<b>Machine assembly.....</b>	<b>37</b>
<b>Electrical connections.....</b>	<b>40</b>
<b>Pre-run setting and test.....</b>	<b>41</b>
<b>Section 5 – Machine operation / stator pressure setting.....</b>	<b>42</b>
<b>General notes for operation .....</b>	<b>44</b>
<b>Section 6 – Simple maintenance.....</b>	<b>45</b>
<b>Clean out shaft – using .....</b>	<b>46</b>
<b>Section 7 – Additional Notes .....</b>	<b>47</b>
<b>Wear issues.....</b>	<b>47</b>
<b>Winterizing and extended periods or storage .....</b>	<b>47</b>
<b>Start up after extended period of storage.....</b>	<b>48</b>
<b>LIMITED WARRANTY POLICY .....</b>	<b>49</b>

## **Section 1 - General Safety information**

### ***Danger***

Follow these instructions very carefully, in order to avoid injury to yourself or others.

Electrically powered machine.

Always ensure that all power to the machine has been turned off and isolated before ANY maintenance / repair work is carried out on the machine.

Ensure that all guards are correctly fitted before starting or attempting to operate the machine.

Ensure that all fasteners are present and correctly fitted before attempting to start or operate the machine.

Ensure that the pump unit is correctly fastened to the front of the hopper unit of the machine, and free of damage before attempting to start or operate the machine.

Ensure that the main electric drive motor assembly, is secured to the rear of the hopper, clamped in place and free from damage before attempting to start or operate the machine.

The MP-25 mixing pump unit can produce high pressures, high torques and can use high voltages. Care must be taken by all users.

Only authorized and trained persons should work with this machine.

## Section 2 - Machine Description

### *Function*

The MP-25 is a mixing pump.

The machine has a drive motor, that turns a drive shaft within a material hopper that in turn feeds material through a mixing / hydration chamber to a progressive cavity rotor stator pump unit that delivers the material from the hopper to the dispense head or otherwise via a material hose / hoses.

The machine is driven by an electric motor powered by 220VAC 3 phase 50/60Hz, via an electronic variable speed inverter supplied by two phase (commonly called single phase) OR three phase 208/240VAC 50/60 Hz grounded electrical supply.

All styles of drives transmit their rotary action through a drive shaft equipped with bridge breakers, and metering flights, which convey the material from the hopper into the mixing / hydration chamber, where a metered supply of water is combined with the material. In the mixing / hydration chamber is where surface hardened mixing arms mix and shear the material with water, towards the pump unit, where further mixing occurs.

The pump unit is a progressive cavity pump unit comprising of a helical rotating “rotor” with the rubber lined “stator”. As the rotor rotates, material is drawn / fed into open rubber cavities, which then transform into “pockets”. The series of pockets, then move from one end of the stator to the other as the rotor turn with respect to the stationary stator, causing the material to be conveyed from the hopper towards the outlet.

Once the material has reached the outlet, it is guided through an output flange assembly, into the dispense hose, through to the hose outlet, where typically a spray nozzle is attached allowing, with the assistance of an auxiliary air supply, the material to be “sprayed” on to the substrate, or simply allowed to discharge from the end of the hose.

A number of different devices can be fitted to the outlet of the tube for different means of application. For details of these different devices please contact your supplier of Machine-Technologies equipment or Machine-Technologies directly.

The primary difference between the three models is the combination of, rotor stator size (D or R style), water flow meter capacity (4 GPM or 7 GPM), and motor HP (5.4 or 7.5).

*Machine illustrations*

**Photographs**

**Single phase,  
STD output,  
unit shown**



# Illustration – 60010120 ASSY, MP 25-SO - SINGLE PHASE 220V

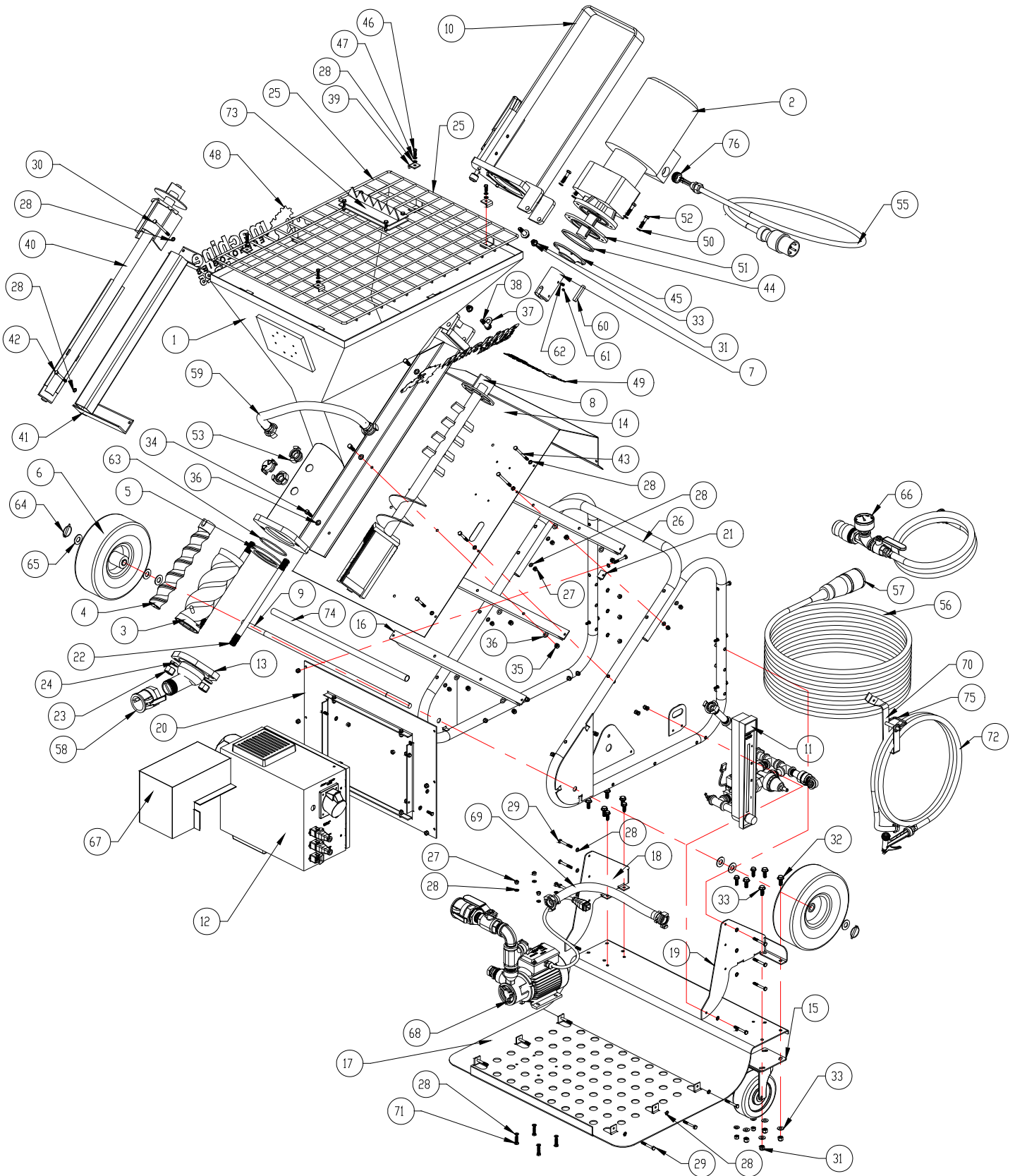



## Bill of Materials – 60010120 ASSY, MP 25-SO - SINGLE PHASE 220V

ITEM NO.	QTY.	PART NO.	DESCRIPTION
1	1	60010137	ASSY,HOPPER-MP-25
2	1	20000004	MOTOR-GEARBOX,ABM-4KW
3	1	30000116	D8-1.5 STATOR-FIXED-YELLOW-EW
4	1	30000117	D8-1.5 ROTOR-HR
5	1	44010257	ADAPTER,PUMP 90MM-MP-25
6	2	30000114	WHEEL, 10" TIRE-RUNFLAT-MP-25
7	1	44010011	DRIVE, AUGER PUMP X
8	1	60010125	ASSY, DRIVE/MIX SHAFT MP-25 SO
9	1	44010256	AXLE, HOPPER MP-25
10	1	60010134	ASSY,UPPER MTR MNT MP-25
11	1	60010136	ASSY,WATER CONTROL MP-25-4GPM
12	1	20000047	BOX, CONTROL MP-25 220V-IPH
13	1	60010129	ASSY, NOZZLE OUTPUT-90MM-MP-25
14	1	44010265	COVER-TOP-MP-25
15	2	30000095	6" CASTER,SWIVEL W/BRAKE,LARGE PLATE
16	3	44010255	BRACE FRAME MP-25
17	1	44010254	PAN,PLATE MP-25
18	1	44010253	SUPPORT,SIDE PAN-RHS-MP-25
19	1	44010252	SUPPORT,SIDE PAN-LHS-MP-25
20	1	44010251	PANEL, MOUNT CONTROL-MP-25
21	2	44010250	SPACER-ANGLE FRAME MP-25
22	2	10000062	ALL-THREAD-3/4-10x13"
23	2	10000035	NUT,HEX STEEL 3/4"-10 UNC
24	2	10000089	WASHER SPLIT HI COLL 3/4-13
25	1	60010133	ASSY,GRID HOPPER ASSY MP-25
26	1	60010132	ASSY,FRAME TUBE FULLRAD-SPACER
27	40	10000017	NUT,NYLOK 1/4-20 UNC
28	84	10000009	WASHER,FLAT 1/4"
29	23	10000082	BOLT,HEX 1/4-20x2"LNG
30	1	10000072	BOLT HEX 1/4-20x3 3/4"
31	10	10000087	NUT,NYLOK 3/8-16 GD5
32	8	10000095	BOLT,HEX 3/8-16-UNC x 1" LNG
33	18	10000044	WASHER 3/8" STEEL
34	10	10000094	BOLT HEX 5/16-18 UNC 1" LONG
35	10	10000092	NUT,NYLOC 5/16-18 GD2
36	20	10000093	WASHER,FLAT 5/16
37	2	10000033	WASHER,PLAIN 1/2"
38	2	10000107	BOLT,SHOULDER 1/2"-1"-3/8-UNC-THD
39	4	44010042	KEEPER,PLATE GRID HOPPER
40	1	60010126	ASSY,SHAFT CLEAN OUT-MP-25
41	1	60010131	ASSY,RACK CLEANOUT MP-25
42	1	10000079	BOLT 1/4-20x2 1/2"LNG
43	3	10000091	BOLT,HEX 1/4-20x3-1-4"LNG
44	1	44010014	ADAPTER,MOTOR-FLANGE
45	1	60010180	ASSY, SEAL GREASE - MOTOR GEARBOX P/D/MP
46	12	10000015	BOLT,HEX 1/4-20x0.75"
47	4	10000008	WASHER,SPLIT 1/4"
48	2	44010275	LABEL,SIDE MP-25
49	1	44010276	LABEL,END MP-25
50	4	10000069	WASHER,SPLIT 5/16"
51	1	44010283	SPACER, MP-25 4KW MOTOR
52	4	10000098	BOLT,HEX 5/16-18 GD5 1 1/2"
53	2	40000009	GEKA STYLE FITTING 3/4" MALE PIPE
54	1	40000011	GEKA STYLE HOSE END CAP
55	1	20000139	ASSY,CABLE MOTOR 4KW-6'-D/MP-25
56	1	20000011	CORD POWER 50FT 3 CORE
57	1	20000010	SOCKET,ALTEC 2PH
58	1	30000029	COUPLER,35MM-CAMLOCK-FEMALE-1 1/2"
59	1	60010139	ASSY WATER HOSE-COMplete-MP-25
60	1	44010015	KEY,SPECIAL, DRIVE DOG 35 DIA SHAFT
61	1	10000005	SCREW,SET 1/4-20x1/4"
62	1	10000099	SCREW,SET 1/4-20-1/2LNG
63	1	40000033	O-RING,0.139"x4.012"OD-BUNA-N
64	2	10000086	PIN,LINCH 3/16x1-1/8x1-3/8SHK
65	6	10000019	WASHER,AXLE 5/8"-1.313"x0.093"
66	1	60010140	TESTER,WATER PRESS - 35MM-MALE-600PSI
67	1	60010144	ASSY,FAN DUCT MP-25
68	1	60010210	ASSY,WATERPUMP, 1PH MP-25 HF
69	1	60010147	ASSY,PUMP HOSE COMPLETE MP-25
70	1	44010287	BRACKET,HOSE MP-25
71	4	10000023	BOLT, HEX 1/4-20UNCx1"
72	1	60010148	ASSY,WASHDOWN HOSE COMPLETE MP-25
73	1	60010063	ASSY,BAG BREAKER - CONT MIX
74	1	20000060	SLEEVE, AXLE-WHITE
75	1	10000071	PIN SNAP, 3/8"-2 1/4" USE
76	1	30000141	BUSHING,FACE PLT 1"MNPT-1/2"FNPT

# Illustration – 60010121 ASSY, MP 25-HO - 3 PHASE - 220V

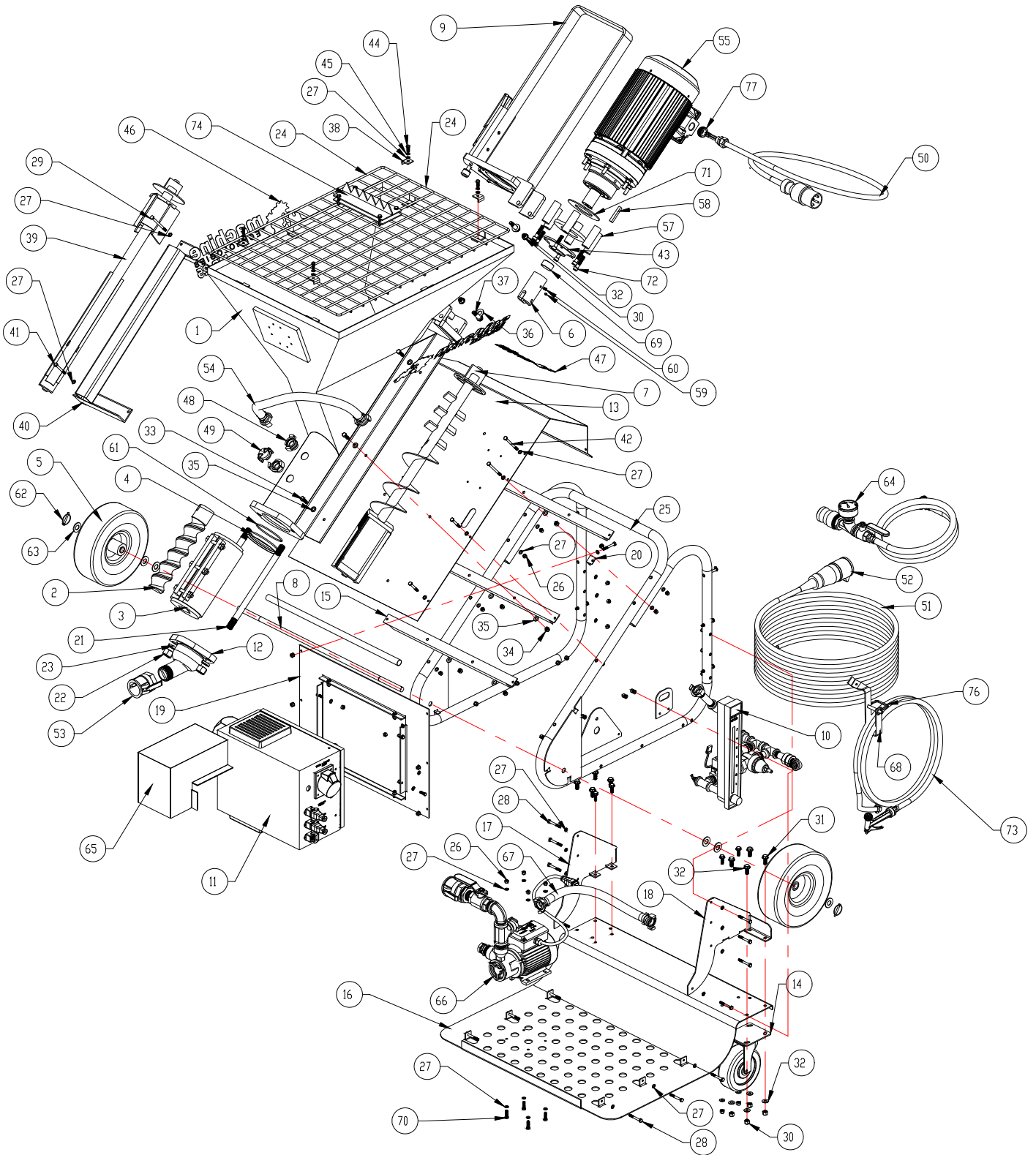

## Bill of Materials – 60010121 ASSY, MP 25-HO - 3 PHASE - 220V

ITEM NO.	QTY.	PART NO.	DESCRIPTION
1	1	60010137	ASSY,HOPPER-MP-25
2	1	30000142	R7-1.5 ROTOR
3	1	30000143	R7-1.5 STATOR-ADJ-YELLOW INT CLAMP
4	1	44010258	ADAPTER,PUMP 113.5MM-MP-25
5	2	30000114	WHEEL, 10" TIRE -RUNFLAT-MP-25
6	1	44010277	DRIVE,AUGER MP-25-SUMI
7	1	60010154	ASSY, DRIVE/MIX SHAFT MP-25 HO
8	1	44010256	AXLE, HOPPER MP-25
9	1	60010134	ASSY,UPPER MTR MNT MP-25
10	1	60010142	ASSY,WATER CONTROL MP-25-7GPM
11	1	20000046	BOX, CONTROL MP-25 220V-3PH
12	1	60010130	ASSY, NOZZLE OUTPUT-113MM-MP-25
13	1	44010265	COVER-TOP-MP-25
14	2	30000095	6" CASTER,SWIVEL W/BRAKE,LARGE PLATE
15	3	44010255	BRACE FRAME MP-25
16	1	44010254	PAN,PLATE MP-25
17	1	44010253	SUPPORT,SIDE PAN-RHS-MP-25
18	1	44010252	SUPPORT,SIDE PAN-LHS-MP-25
19	1	44010251	PANEL,MOUNT CONTROL-MP-25
20	2	44010250	SPACER-ANGLE FRAME MP-25
21	2	10000062	ALL-THREAD-3/4-10x13"
22	2	10000035	NUT,HEX STEEL 3/4"-10 UNC
23	2	10000089	WASHER SPLIT HI COLL 3/4-13
24	1	60010133	ASSY,GRID HOPPER ASSY MP-25
25	1	60010132	ASSY,FRAME TUBE FULLRAD-SPACER
26	40	10000017	NUT,NYLOK 1/4-20 UNC
27	84	10000009	WASHER,FLAT 1/4"
28	23	10000082	BOLT,HEX 1/4-20x2" LNG
29	1	10000072	BOLT HEX 1/4-20x3 3/4"
30	10	10000087	NUT,NYLOK 3/8-16 GD5
31	8	10000095	BOLT,HEX 3/8-16-UNC x 1" LNG
32	18	10000044	WASHER 3/8" STEEL
33	10	10000094	BOLT HEX 5/16-18 UNC 1" LONG
34	10	10000092	NUT,NYLOC 5/16-18 GD2
35	19	10000093	WASHER,FLAT 5/16
36	2	10000033	WASHER,PLAIN 1/2"
37	2	10000107	BOLT,SHOULDER 1/2"-1"-3/8-UNC-THD
38	4	44010042	KEEPER,PLATE GRID HOPPER
39	1	60010126	ASSY,SHAFT CLEAN OUT-MP-25
40	1	60010131	ASSY,RACK CLEANOUT MP-25
41	1	10000079	BOLT 1/4-20x2 1/2" LNG
42	3	10000091	BOLT,HEX 1/4-20x3-1-4" LNG
43	1	60010180	ASSY, SEAL GREASE - MOTOR GEARBOX P/D/MP
44	12	10000015	BOLT,HEX 1/4-20x0.75"
45	4	10000008	WASHER,SPLIT 1/4"
46	2	44010275	LABEL,SIDE MP-25
47	1	44010276	LABEL,END MP-25
48	2	40000009	GEKA STYLE FITTING 3/4" MALE PIPE
49	1	40000011	GEKA STYLE HOSE END CAP
50	1	20000139	ASSY,CABLE MOTOR 4KW-6'-D/MP-25
51	1	20000027	CORD POWER 50FT 4 CORE
52	1	20000033	SOCKET,ALTEC 3PH-220V
53	1	30000029	COUPLER,35MM-CAMLOCK-FEMALE-1 1/2"
54	1	60010139	ASSY WATER HOSE-COMLETE-MP-25
55	1	20000054	MOTOR GEARBOX 5.5KW SUMI-200
56	1	44010280	SEAL, MP-25-SUMI
57	6	44010279	SPACER,MP-25 - SUMI
58	1	44010015	KEY,SPECIAL, DRIVE DOG 35 DIA SHAFT
59	1	10000005	SCREW,SET 1/4-20x1/4"
60	1	10000099	SCREW,SET 1/4-20-1/2" LNG
61	1	40000033	O-RING,0.139"x4.012"OD-BUNA-N
62	2	10000086	PIN,LINCH 3/16x1-1/8x1-3/8SHK
63	6	10000019	WASHER,AXLE 5/8"-1.313"x0.093"
64	1	60010140	TESTER,WATER PRESS - 35MM-MALE-600PSI
65	1	60010144	ASSY,FAN DUCT MP-25
66	1	60010210	ASSY,WATERPUMP, 1PH MP-25 HF
67	1	60010147	ASSY,PUMP HOSE COMPLETE MP-25
68	1	44010287	BRACKET,HOSE MP-25
69	1	44010281	SPACER-SUMI-1 1/2"
70	4	10000023	BOLT, HEX 1/4-20UNCx1"
71	1	44010289	SEAL,PUSHER MP-25 SUMI
72	6	10000100	SCREW,SDC HD 3/8-16x1 3/4" STL
73	1	60010148	ASSY,WASHDOWN HOSE COMPLETE MP-25
74	1	60010063	ASSY,BAG BREAKER - CONT MIX
75	1	20000060	SLEEVE, AXLE-WHITE
76	1	10000071	PIN SNAP, 3/8"-2 1/4" USE
77	1	30000141	BUSHING,FACE PLT 1"MNPT-1/2"FNPT

**Photographs of**

30000039 D8-1.5 STATOR-ADJ-GREEN-INTCLAMP

30000040 D8-1.5 ROTOR



30000041 D6-3 STATOR-FIXED-ORANGE

30000042 D6-3 ROTOR



30000043 D4-3 STATOR-FIXED-GREEN

30000044 D4-3 ROTOR



30000045 R8-1.5 STATOR-ADJ-BLACK-INTCLAMP\

30000046 R8-1.5 ROTOR



## Pump adapters

44010257- ADAPTER,PUMP 90MM-MP-25

(to suit "D" series rotors and stators)

"D" PUMP ADAPTER FOR MP-25

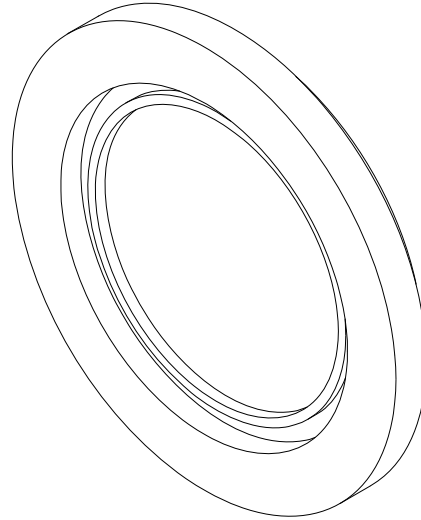

44010258 - ADAPTER,PUMP 113.5MM-MP-25

(to suit "R" series rotors and stators)

"R" PUMP ADAPTER FOR MP-25

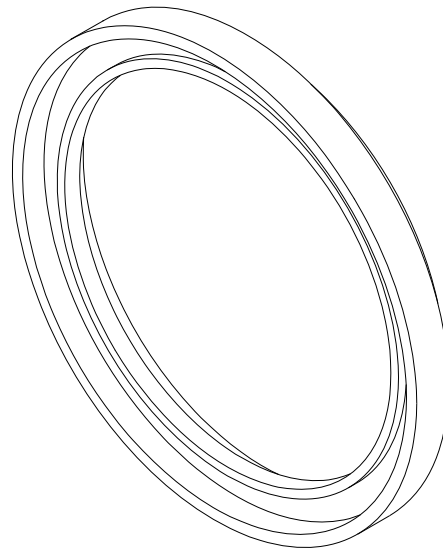



# Water plate assemblies and water pump

60010136 ASSY,WATER CONTROL MP-25-4GPM

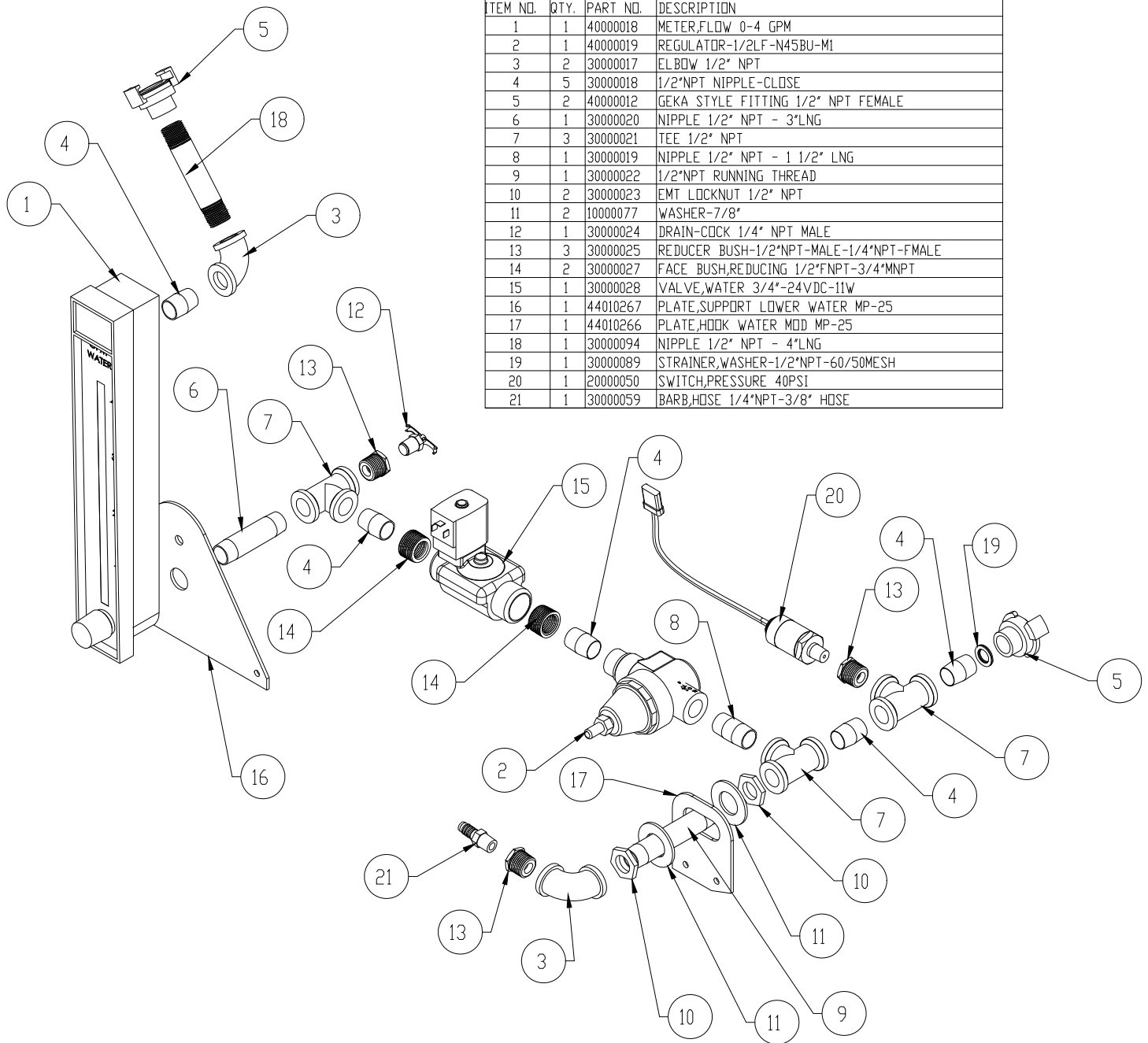

ITEM NO.	QTY.	PART NO.	DESCRIPTION
1	1	40000018	METER, FLOW 0-4 GPM
2	1	40000019	REGULATOR-1/2LF-N45BU-MI
3	2	30000017	ELBOW 1/2" NPT
4	5	30000018	1/2"NPT NIPPLE-CLOSE
5	2	40000012	GEKA STYLE FITTING 1/2" NPT FEMALE
6	1	30000020	NIPPLE 1/2" NPT - 3" LNG
7	3	30000021	TEE 1/2" NPT
8	1	30000019	NIPPLE 1/2" NPT - 1 1/2" LNG
9	1	30000022	1/2"NPT RUNNING THREAD
10	2	30000023	EMT LOCKNUT 1/2" NPT
11	2	10000077	WASHER-7/8"
12	1	30000024	DRAIN-COCK 1/4" NPT MALE
13	3	30000025	REDUCER BUSH-1/2"NPT-MALE-1/4"NPT-FEMALE
14	2	30000027	FACE BUSH, REDUCING 1/2"FNPT-3/4"MNPT
15	1	30000028	VALVE, WATER 3/4"-24VDC-11W
16	1	44010267	PLATE, SUPPORT LOWER WATER MP-25
17	1	44010266	PLATE, HOOK WATER MOD MP-25
18	1	30000094	NIPPLE 1/2" NPT - 4" LNG
19	1	30000089	STRAINER, WASHER-1/2"NPT-60/50MESH
20	1	20000050	SWITCH, PRESSURE 40PSI
21	1	30000059	BARB, HOSE 1/4"NPT-3/8" HOSE

# 60010142 ASSY,WATER CONTROL MP-25-7GPM

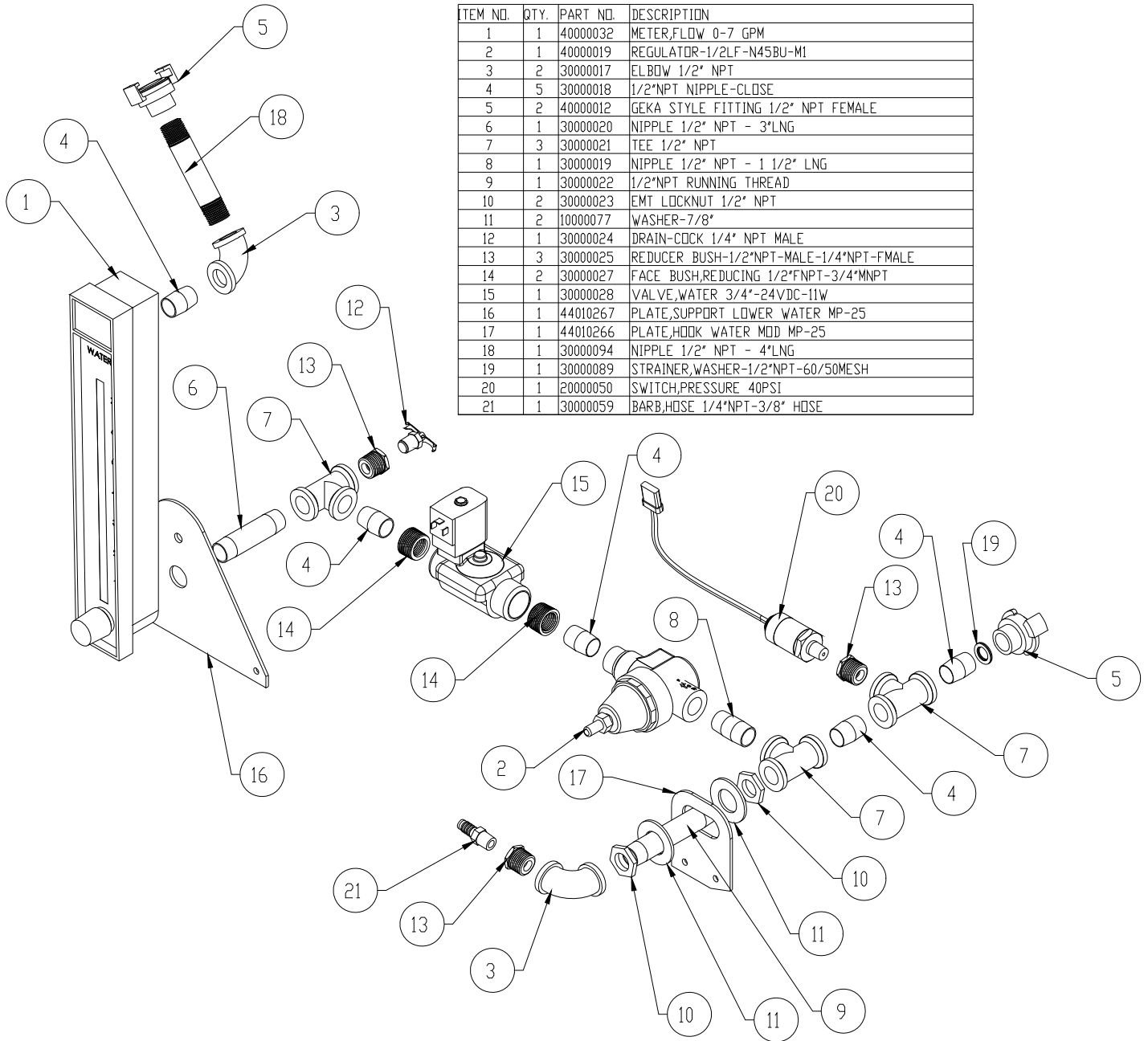

ITEM NO.	QTY.	PART NO.	DESCRIPTION
1	1	40000032	METER, FLOW 0-7 GPM
2	1	40000019	REGULATOR-1/2LF-N45BU-MI
3	2	30000017	ELBOW 1/2" NPT
4	5	30000018	1/2"NPT NIPPLE-CLOSE
5	2	40000012	GEKA STYLE FITTING 1/2" NPT FEMALE
6	1	30000020	NIPPLE 1/2" NPT - 3" LNG
7	3	30000021	TEE 1/2" NPT
8	1	30000019	NIPPLE 1/2" NPT - 1 1/2" LNG
9	1	30000022	1/2"NPT RUNNING THREAD
10	2	30000023	EMT LOCKNUT 1/2" NPT
11	2	10000077	WASHER-7/8"
12	1	30000024	DRAIN-COCK 1/4" NPT MALE
13	3	30000025	REDUCER BUSH-1/2"NPT-MALE-1/4"NPT-FEMALE
14	2	30000027	FACE BUSH,REDUCING 1/2"FNPT-3/4"MNPT
15	1	30000028	VALVE,WATER 3/4"-24VDC-11W
16	1	44010267	PLATE,SUPPRT LOWER WATER MP-25
17	1	44010266	PLATE,HOOK WATER MOD MP-25
18	1	30000094	NIPPLE 1/2" NPT - 4" LNG
19	1	30000089	STRAINER,WASHER-1/2"NPT-60/50MESH
20	1	20000050	SWITCH,PRESSURE 40PSI
21	1	30000059	BARB,HOSE 1/4"NPT-3/8" HOSE



60010210 ASSY,WATERPUMP, 1PH MP-25 HF - complete

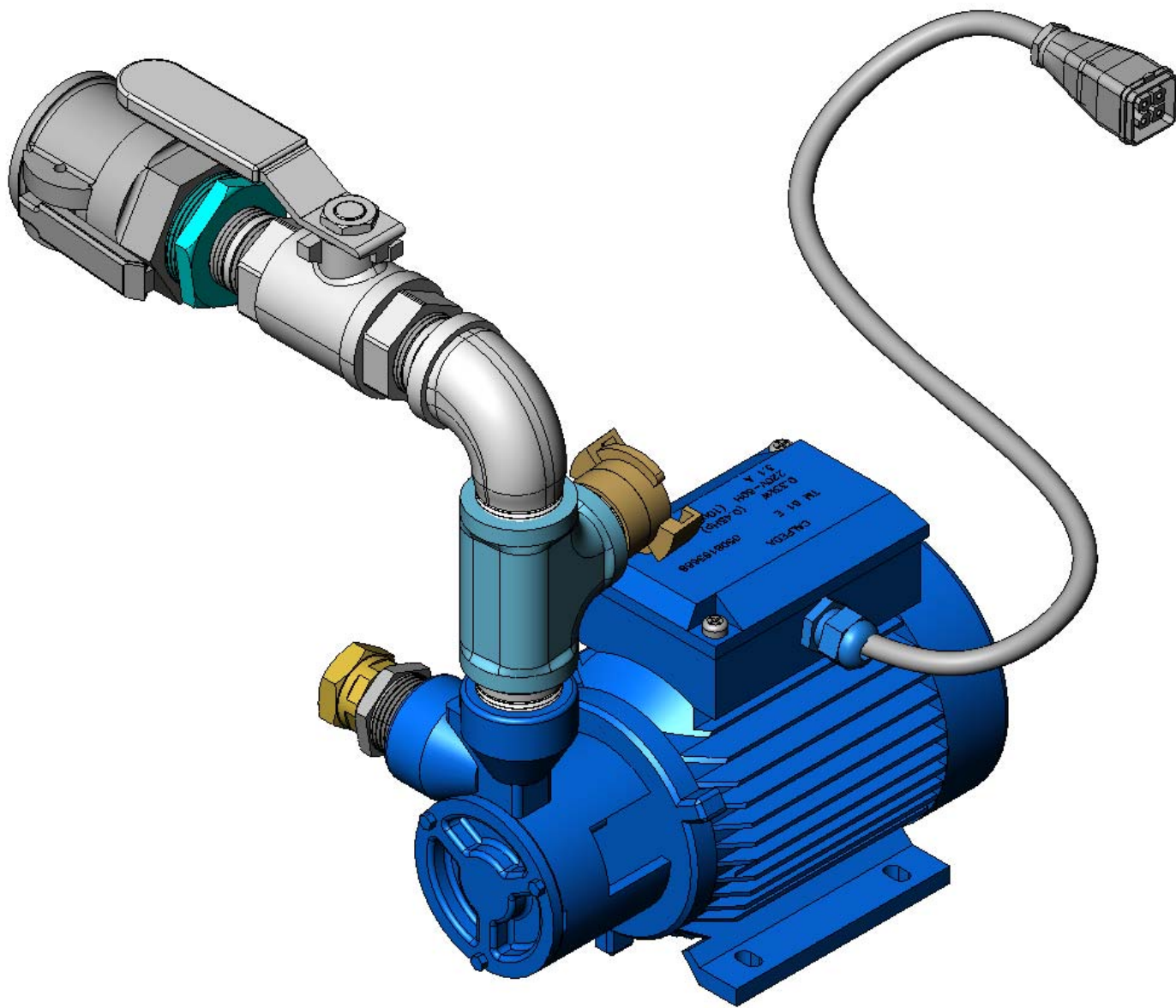

## Motor mount

60010134 ASSY,UPPER MTR MNT MP-25

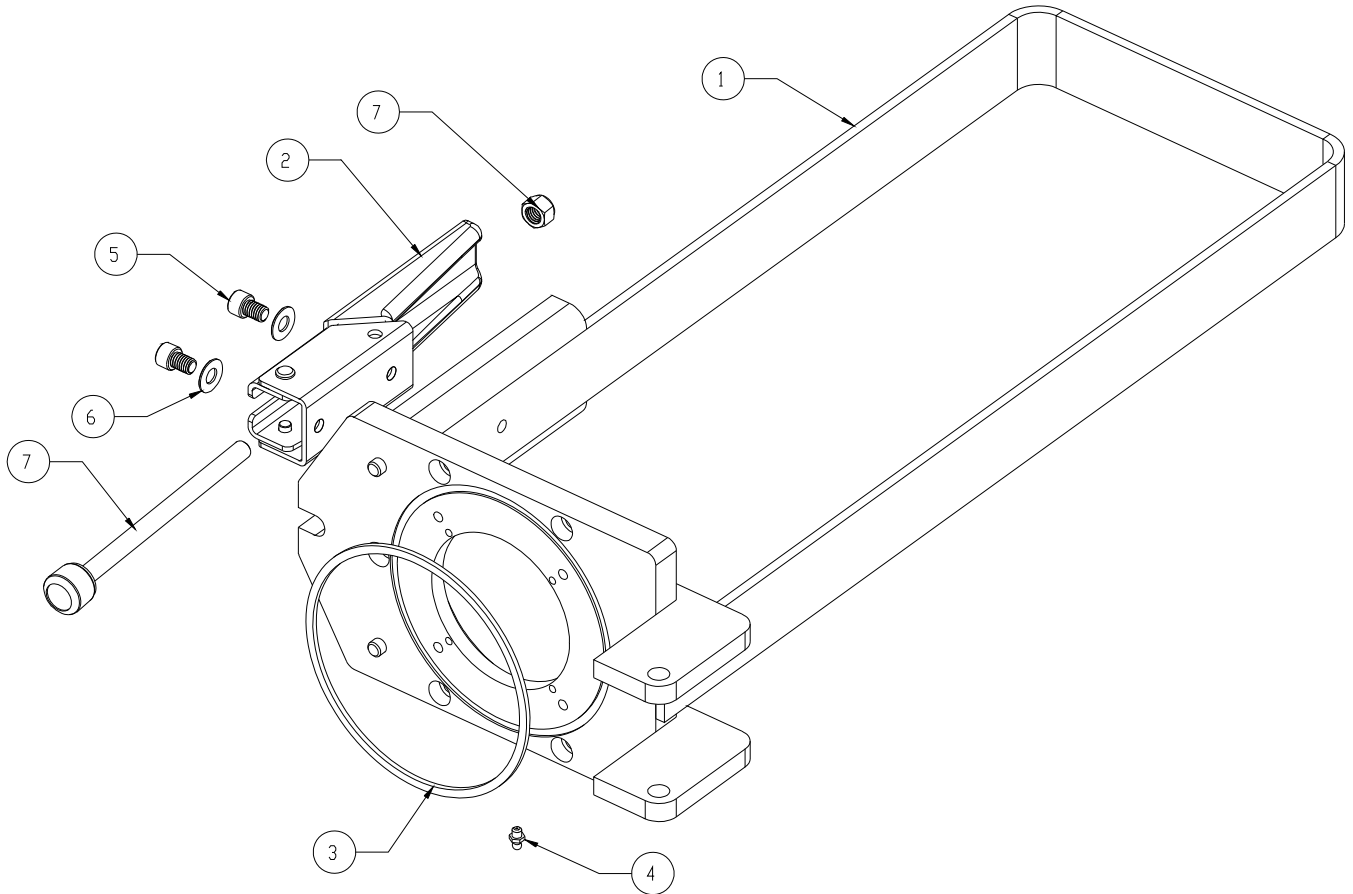

ITEM NO.	QTY.	PART NO.	DESCRIPTION
1	1	60010135	WELDMENT,UPPER MTR MNT MP-25
2	1	10000048	CATCH,DRAW BATCH MIXER
3	1	44010278	SEAL,MP-25-MOTOR FLANGE
4	1	40000004	NIPPLE,GREASE-1/4"-28
5	2	10000101	SCREW,SOC HD 3/8-16x1/2" ZNPLT
6	2	10000044	WASHER 3/8" STEEL
7	1	60010150	ASSY, DRAW PIN MP-25

**Mixing shafts complete, and clean out shaft complete**

60010125 ASSY, DRIVE/MIX SHAFT MP-25 SO

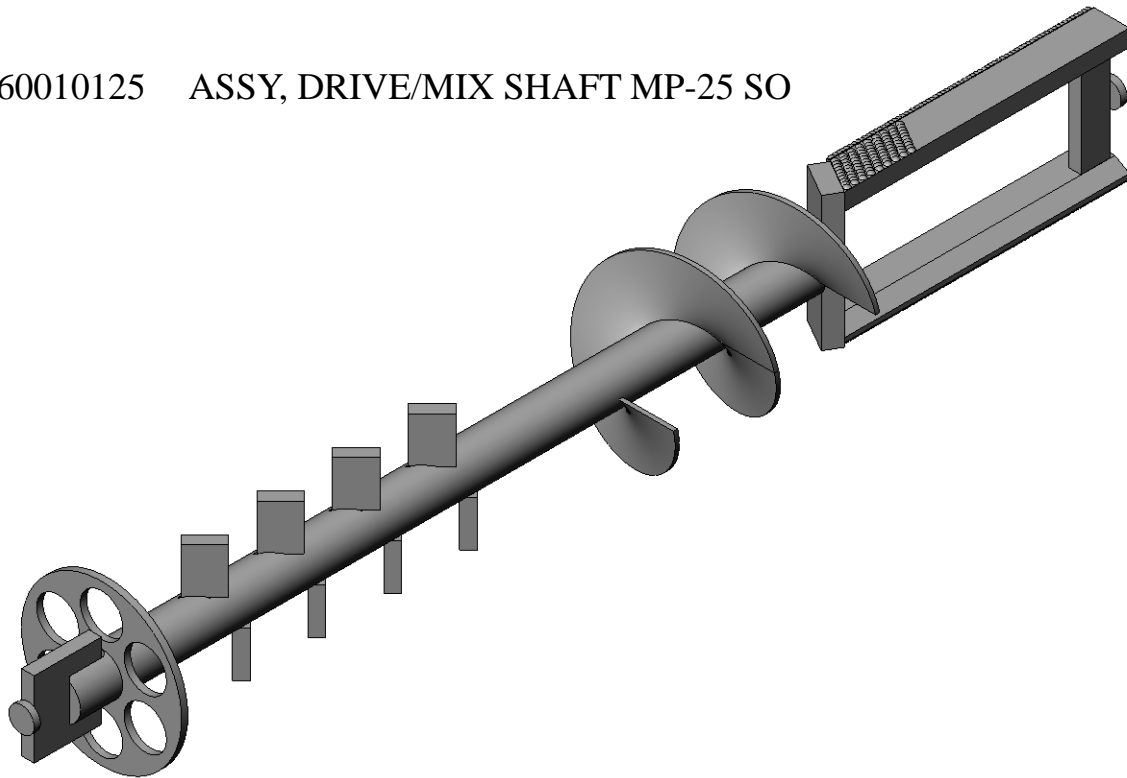

60010154 ASSY, DRIVE/MIX SHAFT MP-25 HO

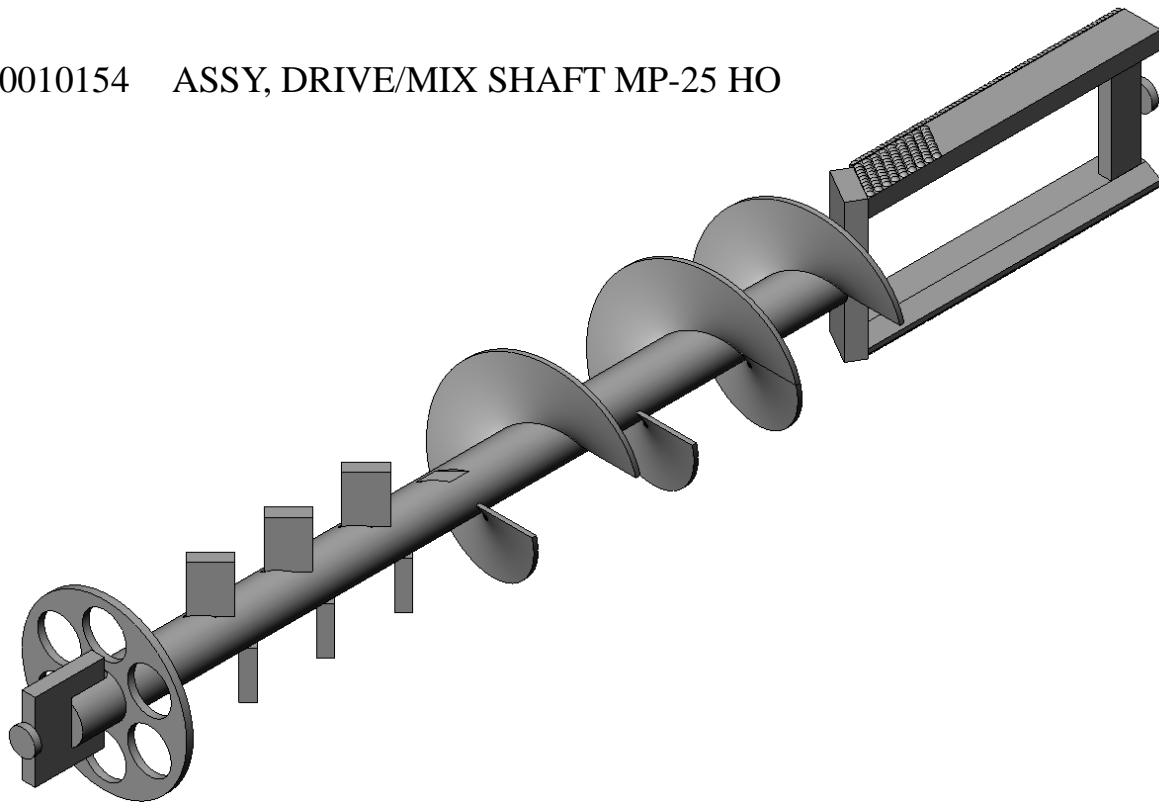

60010126 ASSY, SHAFT CLEAN OUT-MP-25

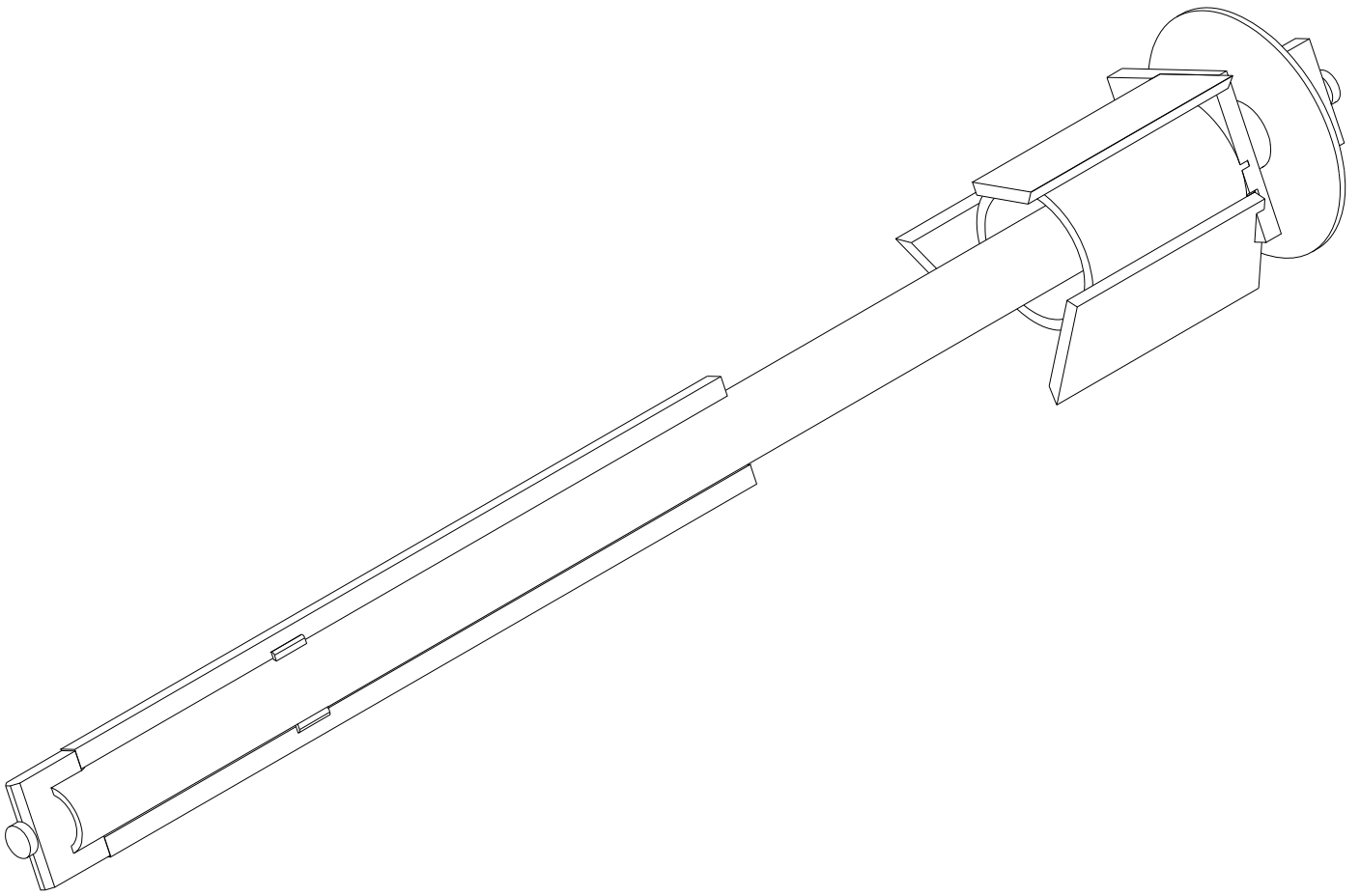

**Water pressure tester, water hoses and fan duct**

60010140 TESTER, WATER PRESS - 35MM-MALE-600PSI

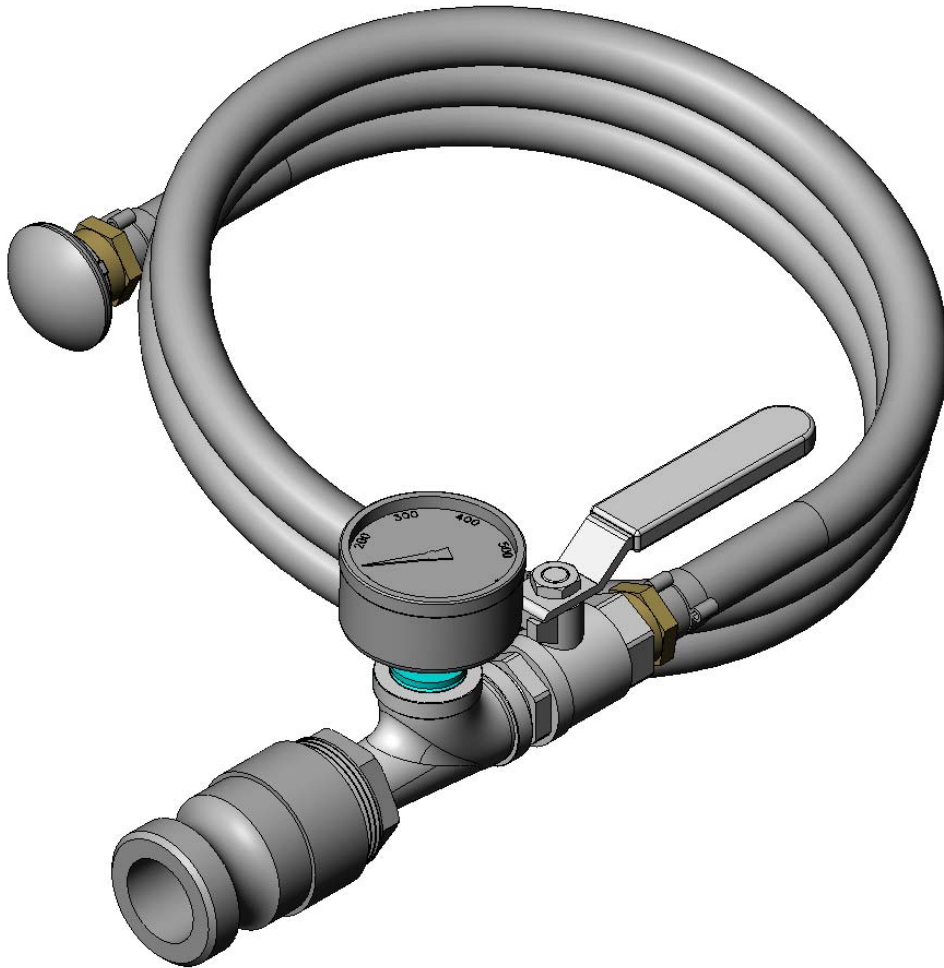

60010139 ASSY WATER HOSE-COMPLETE-MP-25

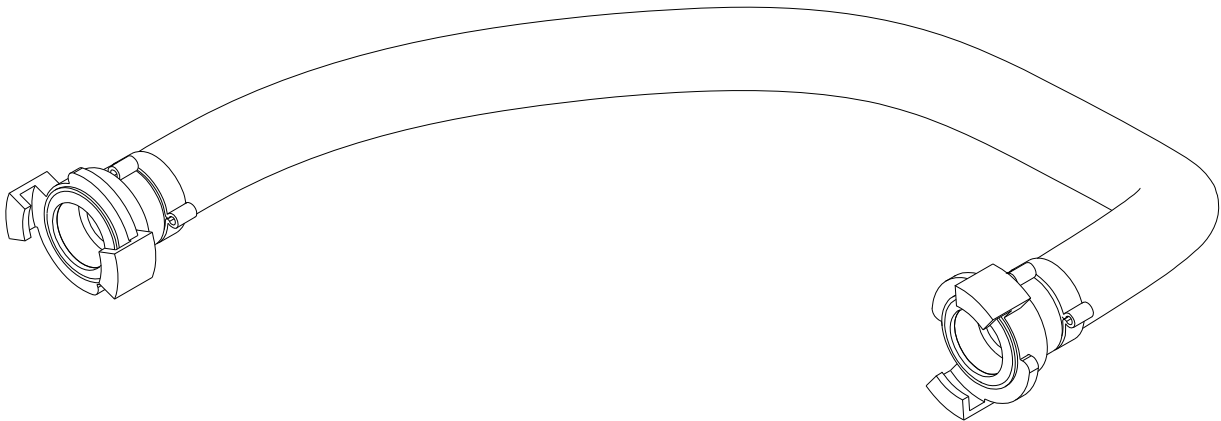

60010147 ASSY,PUMP HOSE COMPLETE MP-25

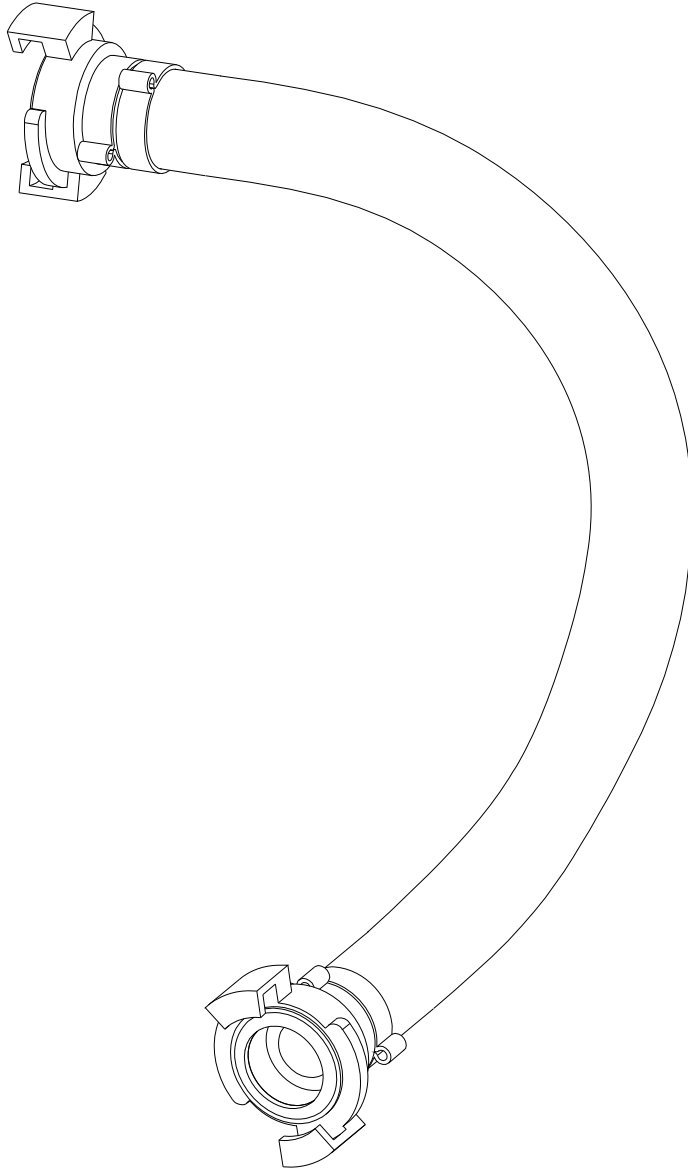

60010144 ASSY,FAN DUCT MP-25

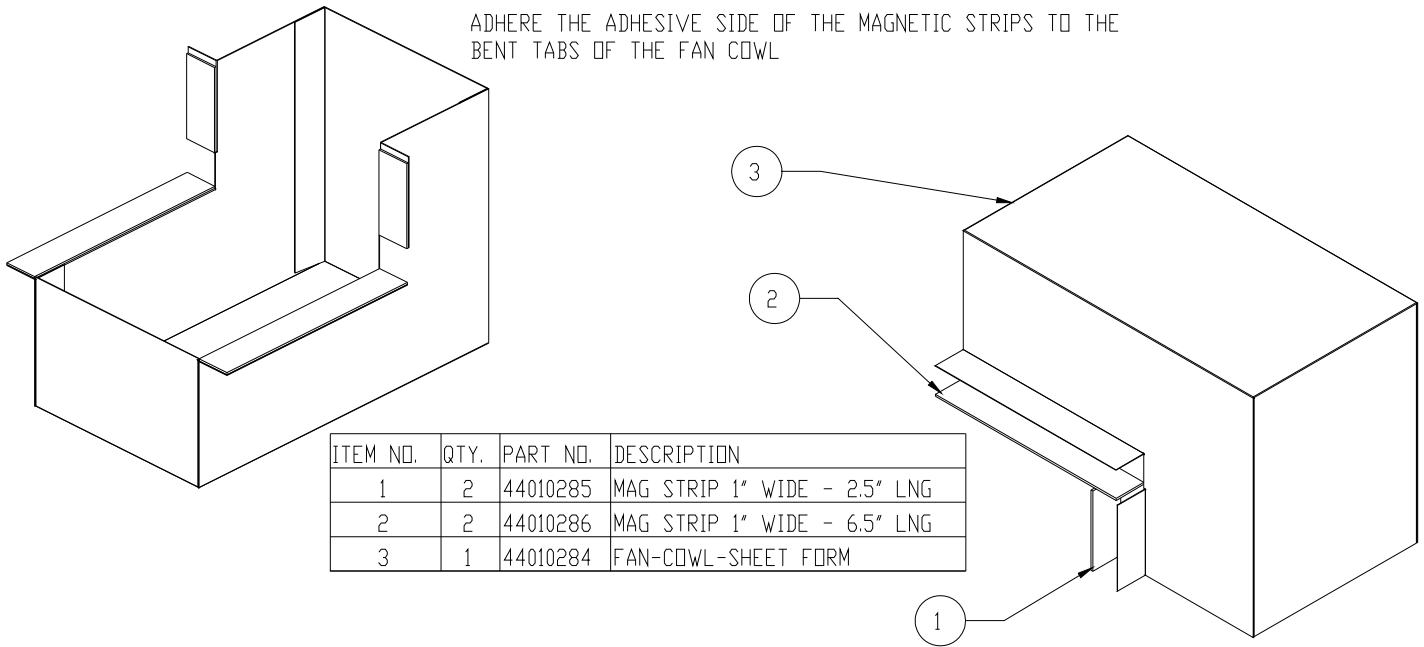

60010148 ASSY,WASHDOWN HOSE COMPLETE MP-25

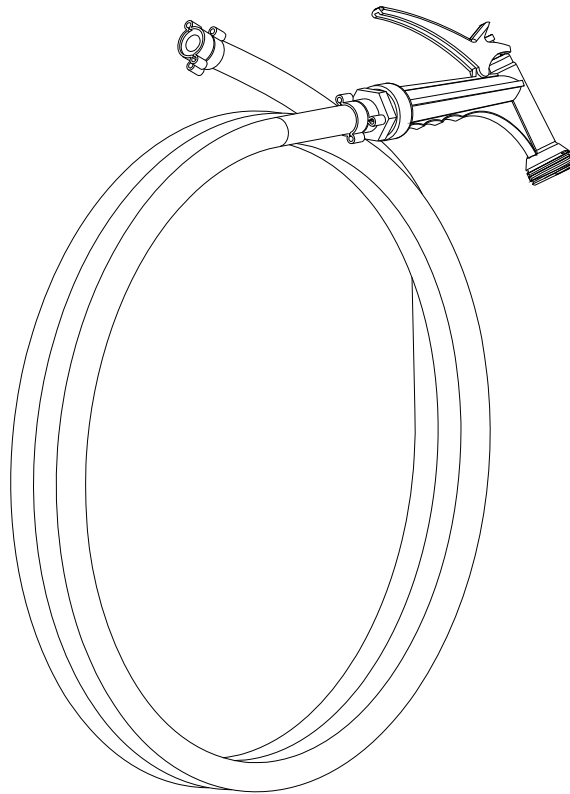

## 20000124 REMOTE, WIRED SPRAY GUN MNT-MP25 – option only

A wired spray gun or hose mounted remote is available as an option allowing the remote control of the stop and start function of the mixing pump. The controls are affixed to the gun or the hose using supplied hook and loop straps (Velcro®), and the end of the control cable plug into the MP-25 control box. The remote is supplied with a single 40' length of cable suitable for one 33' length of hose.

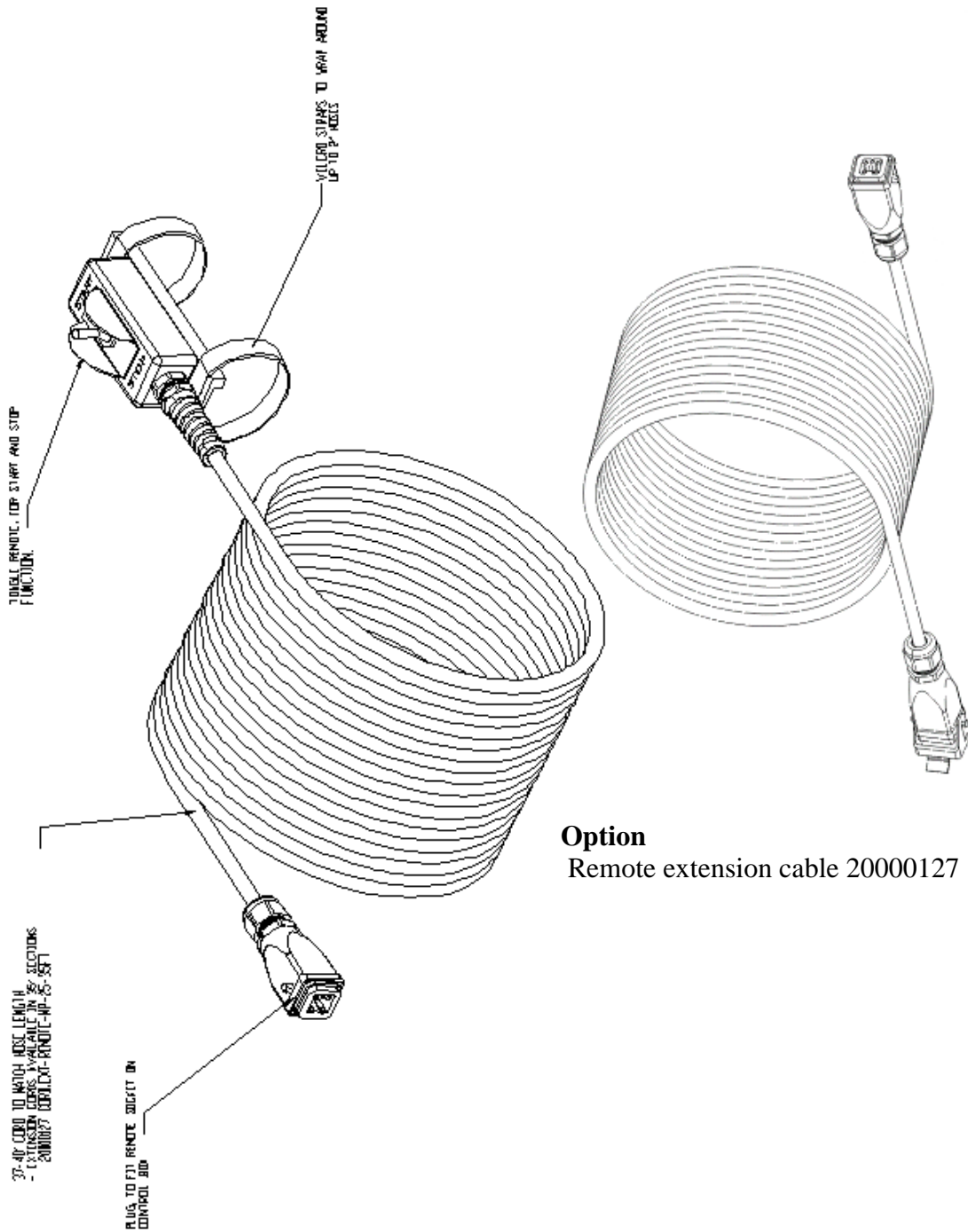



# Electric Drive unit

Typical 3 PH layout – 7.5HP (5.5kW) shown

ITEM NO.	QTY.	PART NO.	DESCRIPTION
1	1	60010134	ASSY,UPPER MTR MNT MP-25
2	6	44010279	SPACER,MP-25 - SUMI
3	1	44010280	SEAL, MP-25-SUMI
4	1	44010289	SEAL,PUSHER MP-25 SUMI
5	1	44010277	DRIVE ALIGER MP-25-SUMI
6	1	44010281	SPACER-SUMI-1 1/2"
7	1	20000054	MOTOR_GEARBOX 5.5KW SUMI-200
8	6	10000100	SCREW,SOC HD 3/8-16x1 3/4" STL
9	1	44010013	SEAL,GREASE MOTOR G/BOX
10	1	44010296	GREASE TUBE - SUMI
11	4	10000002	DOWEL, SEAL RETAINER
12	2	10000005	SCREW,SET 1/4-20x1/4"
13	4	10000105	SCREW,SET 5/16-18 -5/16LNG

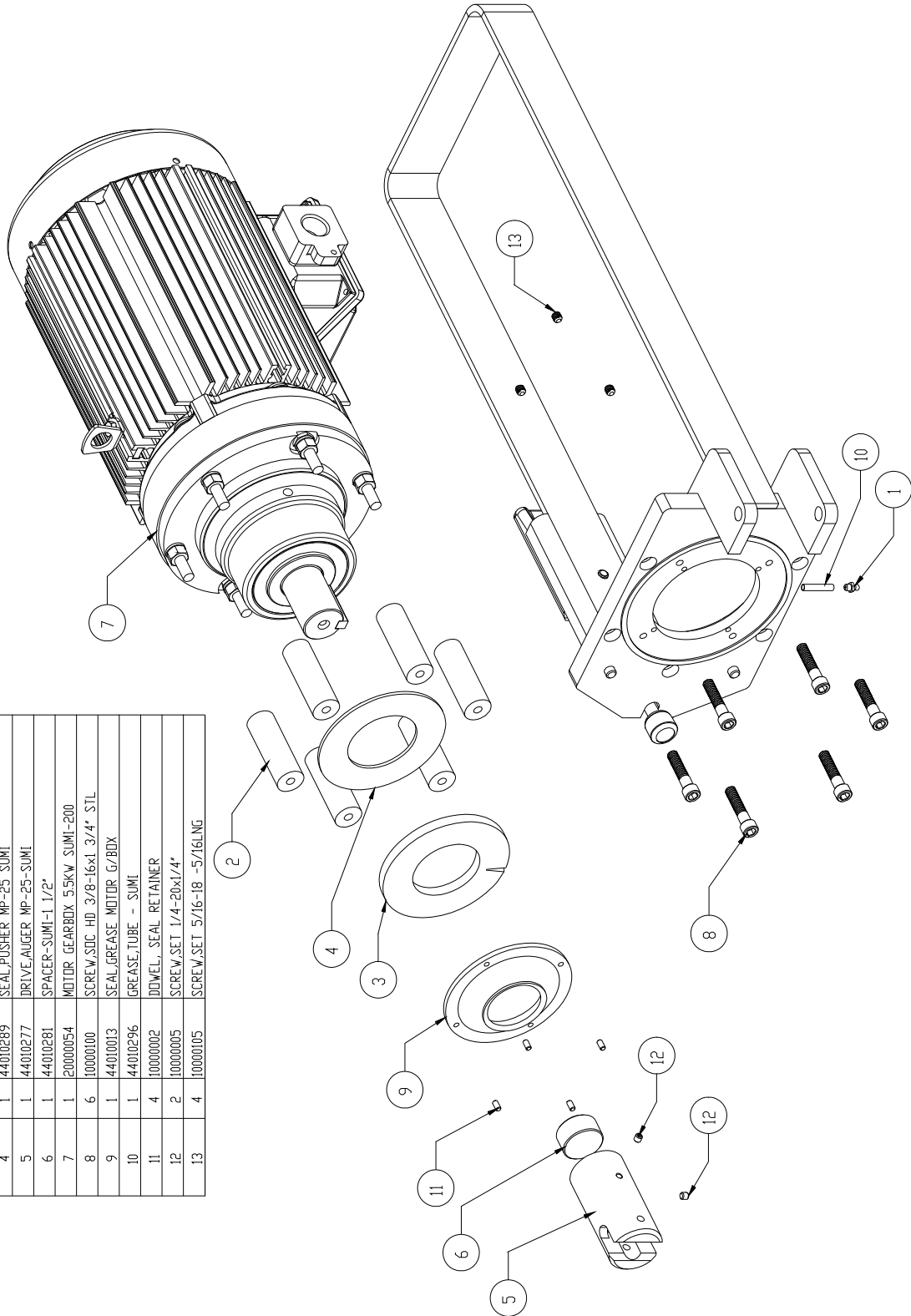

## Cutaway view of Grease seal, Sumi seal, seal pusher, and grease tube

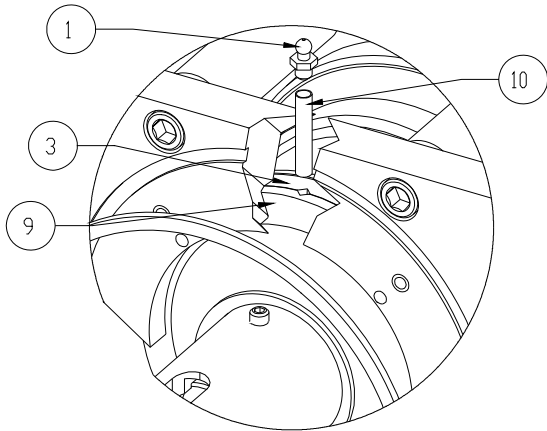

A (1 : 2)

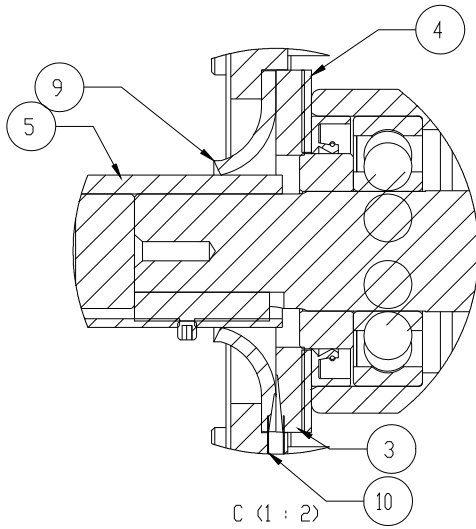

C (1 : 2)

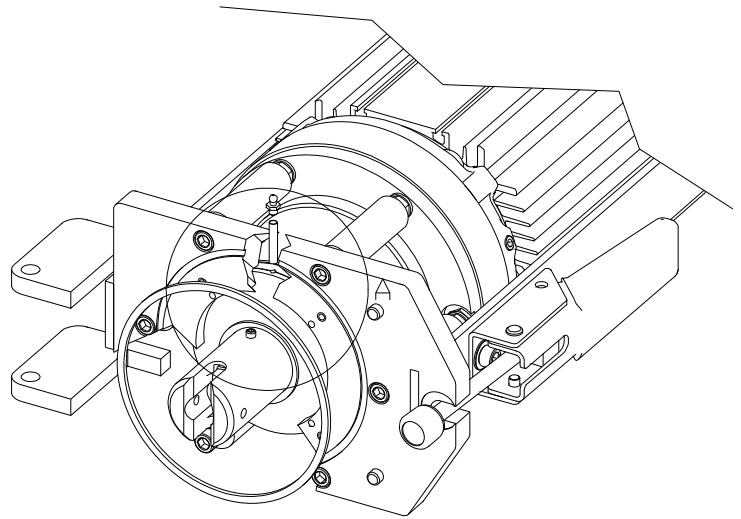

Pay particular attention to the alignment of the grooves in the seals and the grease tube.

**Unit must be greased on a job by job basis.**

Alternate motor fitment and seal configuration.

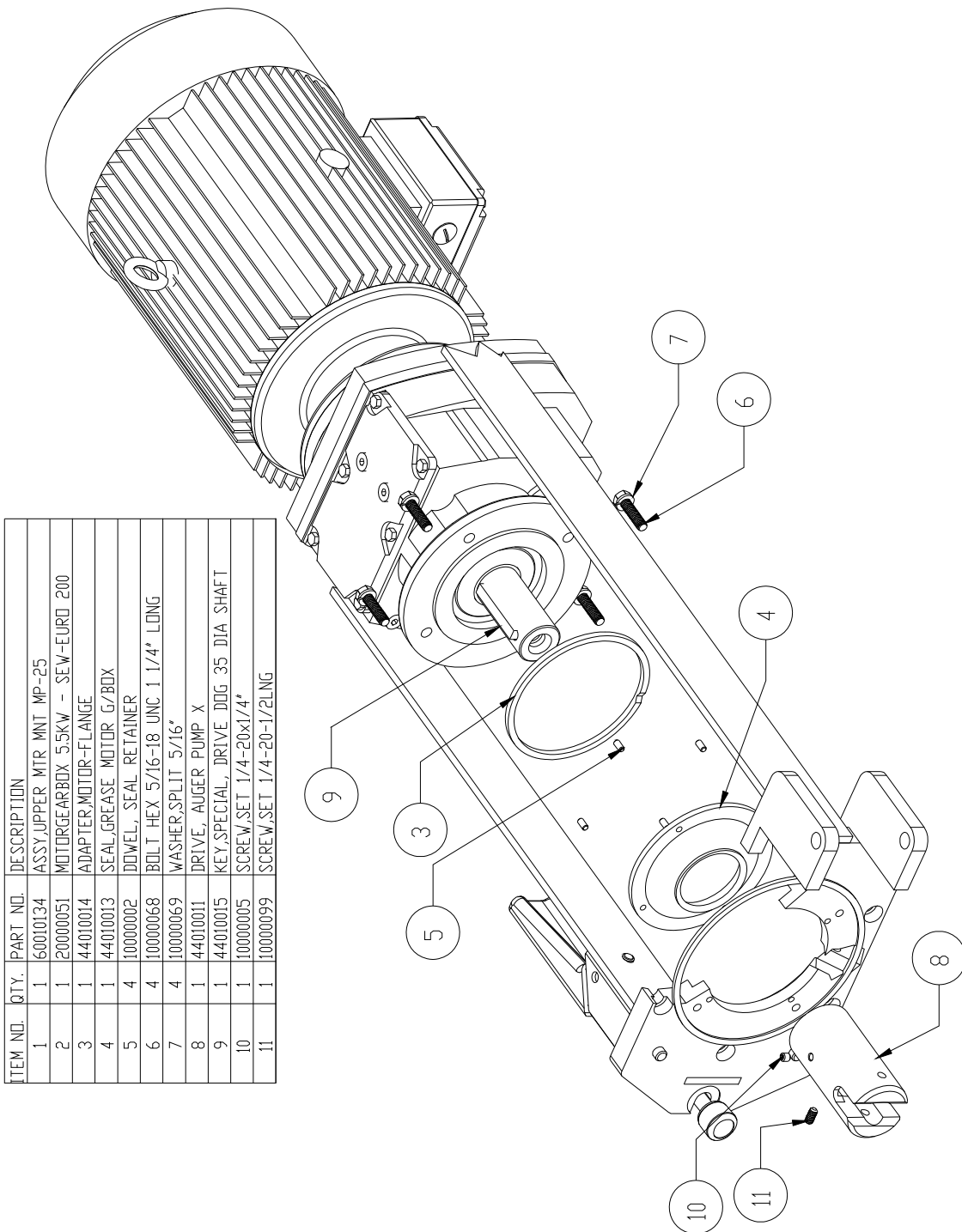

**Note 5.3 HP (4kW) Single phase unit uses an additional spacer between motor flange and item 3, due to a longer shaft length. Item 6 are then 1 1/2" long. – see page 8**

Shown in cutaway view of upper motor mount. Unit must be greased on a daily / job-by-job basis.

Cutaway view of seal, dowel, adapter and shaft arrangement

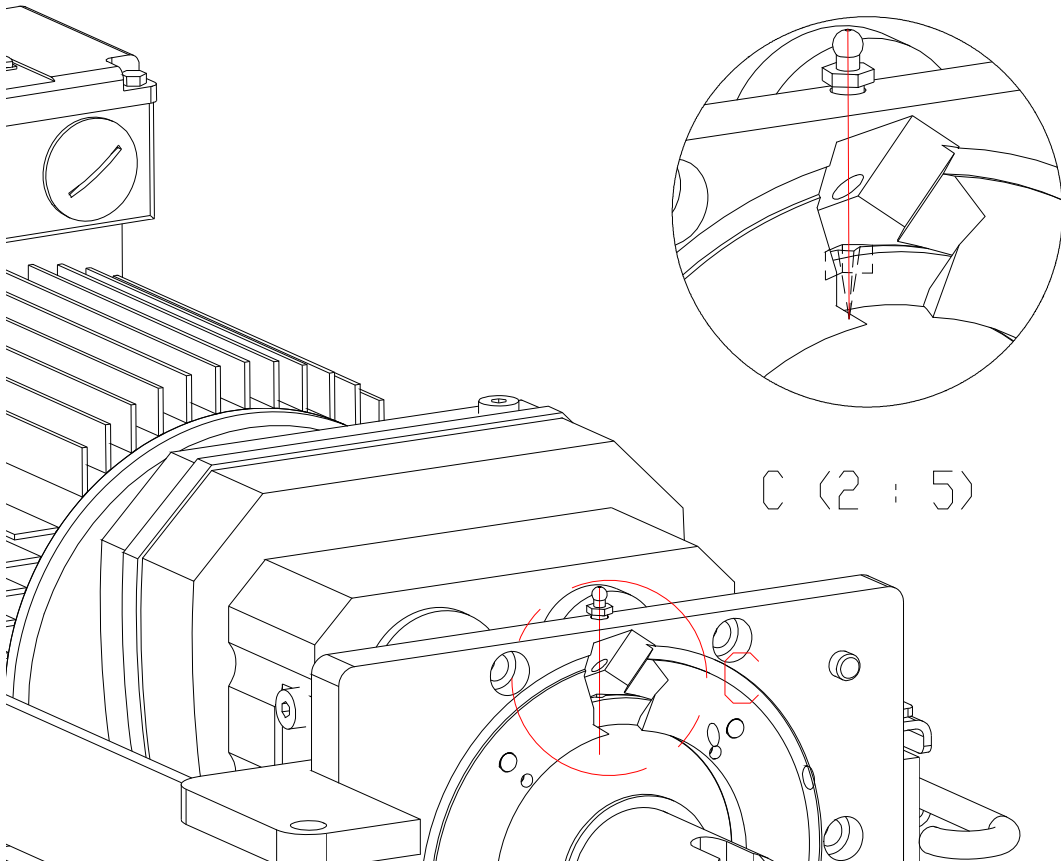
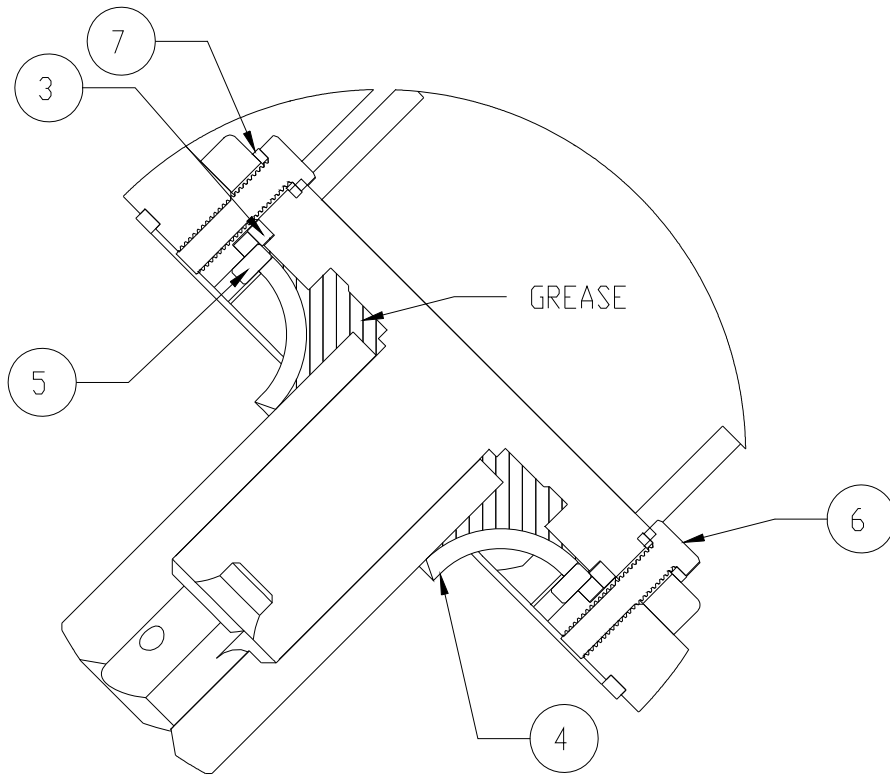

Showing relationship between grooves in adaptor and seal, to allow grease to flow

## Electronic Drive module – 20000046 / 47

### Function

The drive module takes the input power via an isolator and breakers and supplies to the drive motor via an adjustable frequency phase inverter. Prior to the power being provided to the motor various addition functions have to be completed, such as water pressure signal, and remote present / by-passed. The module runs at full speed after a 2 second acceleration period at an operator selected speed chosen from three preconfigured options, when the “Start” button is pressed either on the panel or on the remote. The unit decelerates to zero RPM following the “Stop” button being pressed on either the panel or the remote.

Whenever the reverse switch is actuated, the unit will turn in reverse, either from stationary or from a forward running condition after decelerating to rest. Upon the unit turning in reverse, the water solenoid is de-energized, until forward motion is reselected.

### **Important note.**

The control module is resistant to water splashes, **ONLY** when the fan cowl is fitted. Failure to keep the cowl in place allows water splashed under the machine top cover to enter into the box allowing contact with the internal electrical components and causing damage.

After each use and subsequent clean down, the module must be disconnected from the electrical supply, opened and the inside inspected for debris and / or water ingress. **ALL** water and debris must be removed immediately, using wipe cloths then compressed air.

The electronic Drive module comprises of a variable speed frequency inverter, allowing the use of 208 / 220VAC two phase, on 60010120 , or 208 / 220VAC 3PH on the other models to run the high torque 3 Phase gear motor. The inverter unit is rated at 7.5 HP providing plenty of power to run the MP-25 unit.

The module is supplied with an input plug allowing immediate wiring into your own 220VAC 2 phase or 3 Phase (as applicable depending up on the model) supply (Must be carried out by an approved installer). The motor is supplied with a pre-wired plug that fits into the 3 Phase outlet of the drive module.

The module has a main power isolator, a combined stop / start switch, a spring loaded reverse switch, a speed control (three speed positions), a series of indicator lights, an inverter drive, internal breakers for each input phase, a water pump motor switch / contactor, a water pressure switch relay, and a large capacity cooling fan, with removable shroud and filter enclosure, in addition to the fan fitted to the inverter, a water pump connection socket, a water pressure switch socket and a water solenoid socket, a remote socket providing the optional capability for remote operation.

Fixed to the sides of the control module are a series of polarized plugs, each is color coded to suit the mating socket.

Each machine is equipped with a water pump, used as a booster pump to help ensure consistent water pressure, and as such the unit will not run unless the water pressure switch is closed. For maintenance the water pressure switch can be over ridden using the supplied “dummy” plug, attached to the side of the module.

Each machine is equipped with a water supply module which is operated by a signal from the control module to open and close a solenoid valve which starts and stops the water flow.

As an option the machine can be supplied with the “spray gun” mount, wired remote control (20000124), allowing the operation of the machine from the end of a standard 33’ length of hose or further with the use of additional extension cords (20000127). The remote provides stop / start functionality only. The machine will NOT run without either the remote being attached, or the remote “dummy” plug being attached, the “dummy” plug is attached to the side of the module and color coded similarly to the water pressure “dummy” plug.

#### **Note – all models**

- If there is not 40Psi or more of water pressure the pressure switch will not operate and as such the machine will not operate in the forward direction as the speed circuit is not enabled. **THE MACHINE WILL RUN IN REVERSE FOR DE-PRESSURIZATION OF THE HOSE LINE** should the water feed fail. If by connecting the water pressure bypass plug the machine functions normally, then water pressure is insufficient. If a restricted water feed is present then 40PSI might be available when a no flow condition exists, but under flow the pressure will drop.
- Both machines are now fitted with single phase water pumps as standard, to eliminate confusion with rotation selection.
- Both machines have their direction of rotation factory set, and direction of rotation is not affected by the manner in which either the single or three phase connections are hooked up.

# Illustrations

20000046 – 3 phase / 20000047 – single phase (note no externally visible difference)

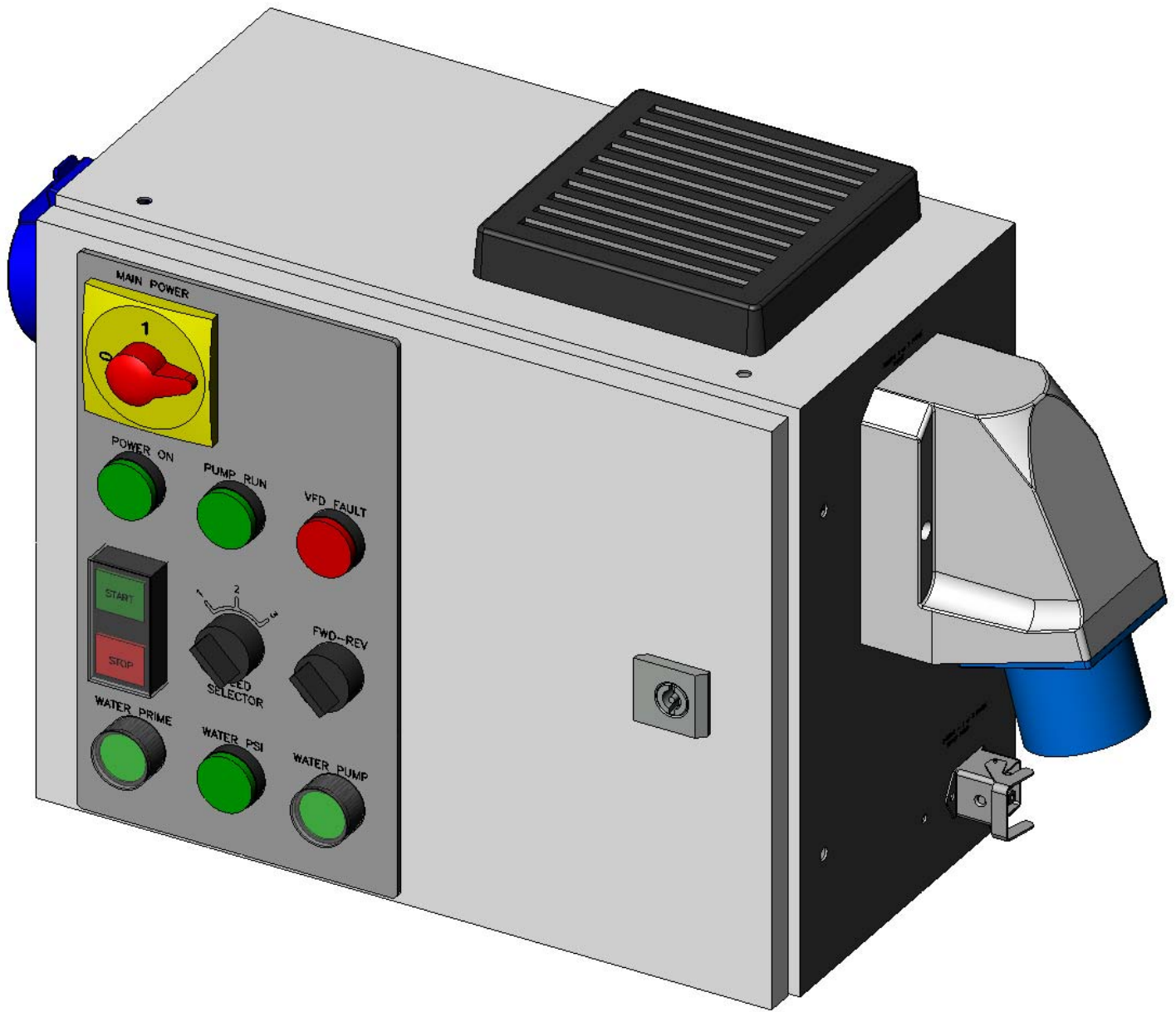

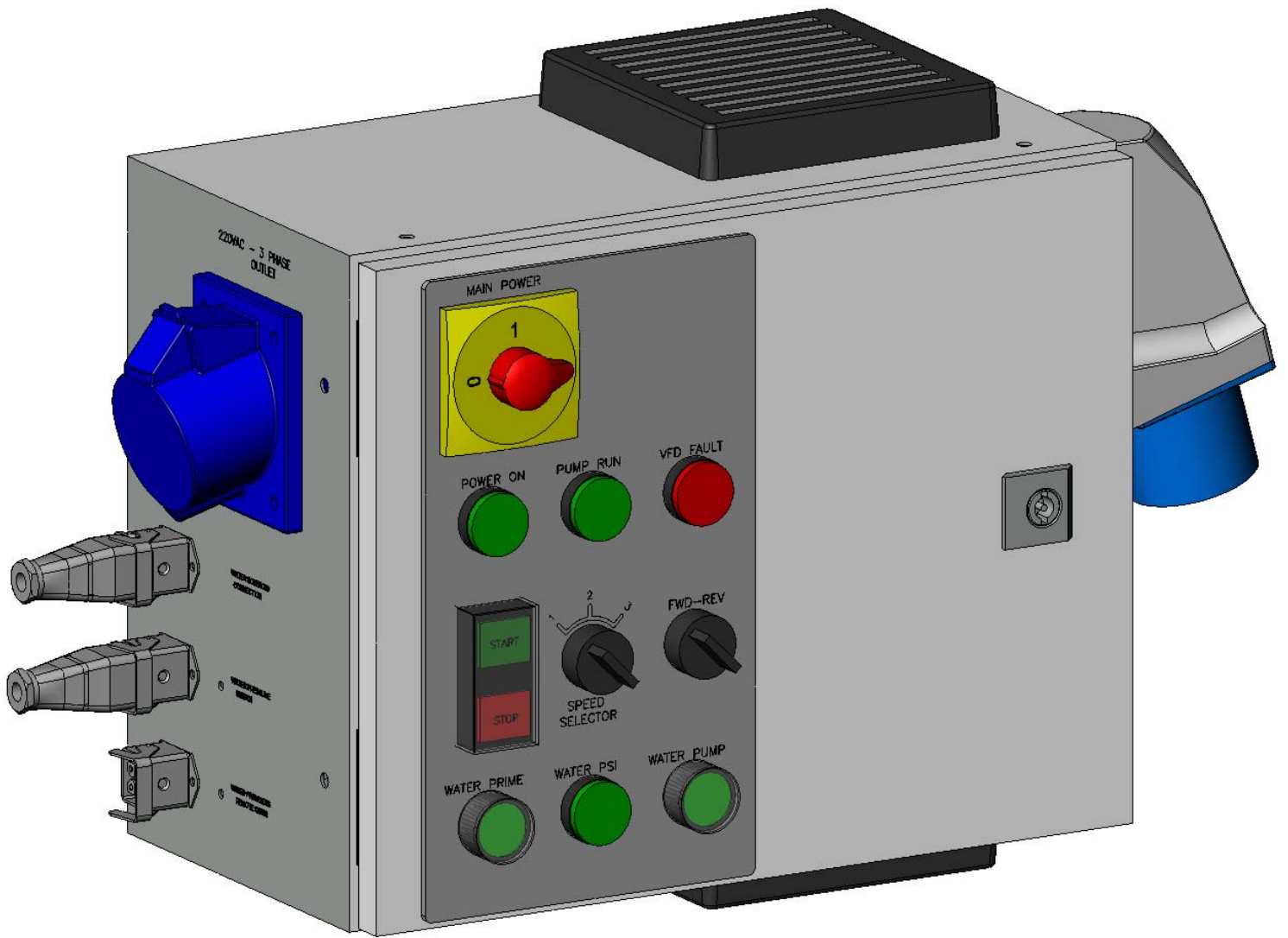



With cowl

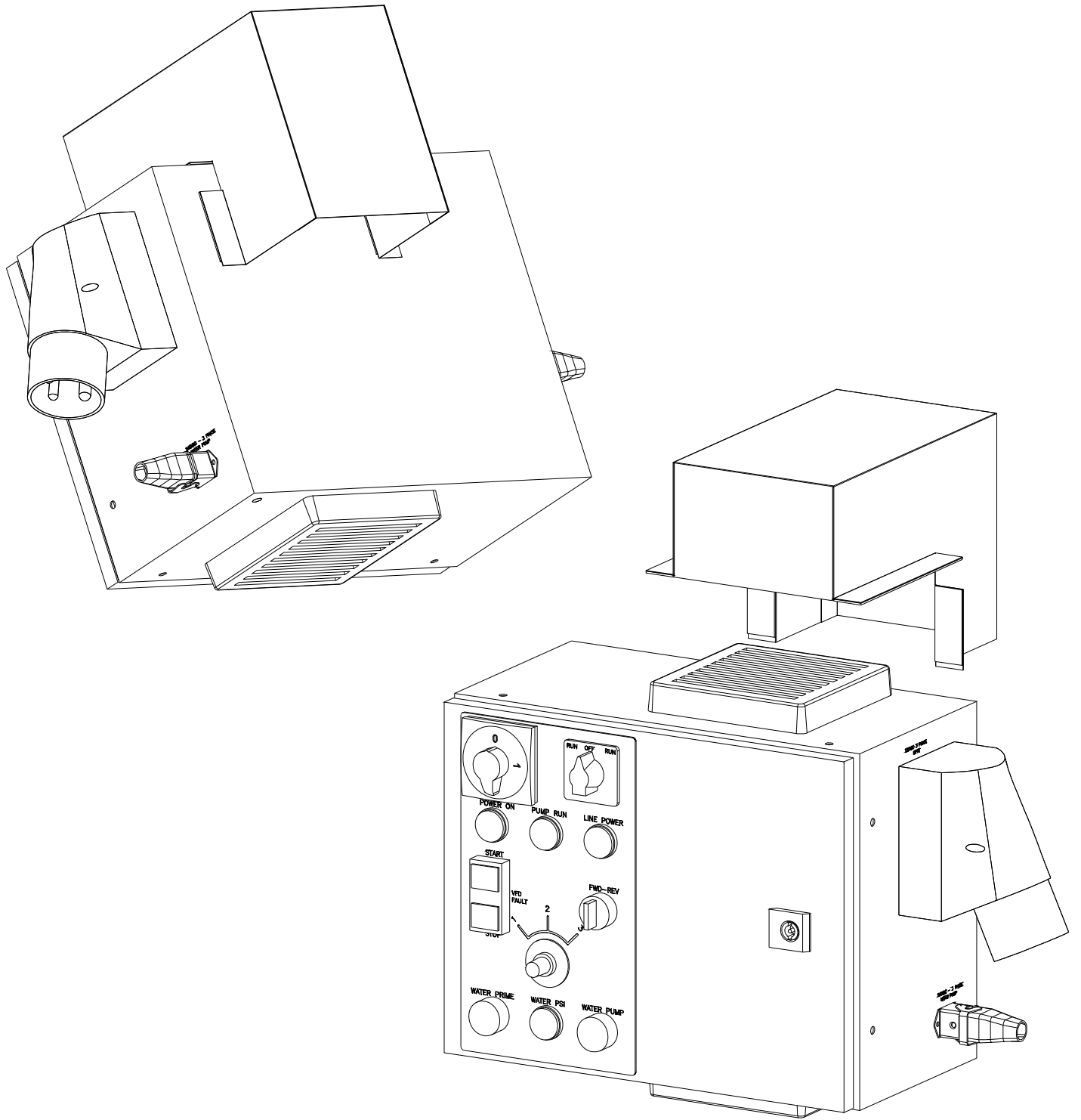

### Section 3 – Transportation and positioning

The machine is typically manually transported around the job site using the two swivel casters at the rear of the machine to steer, with the larger wheels at the front.

The machine can be picked up using a forklift, by simply inserting the forks under the base from the rear, and ensuring that they are close enough together to prevent damage to the casters. Each caster has a locking lever, which, when in the horizontal position the brake is OFF, and when angled in either direction are locked. Ensure that the locks are OFF when moving the machine.

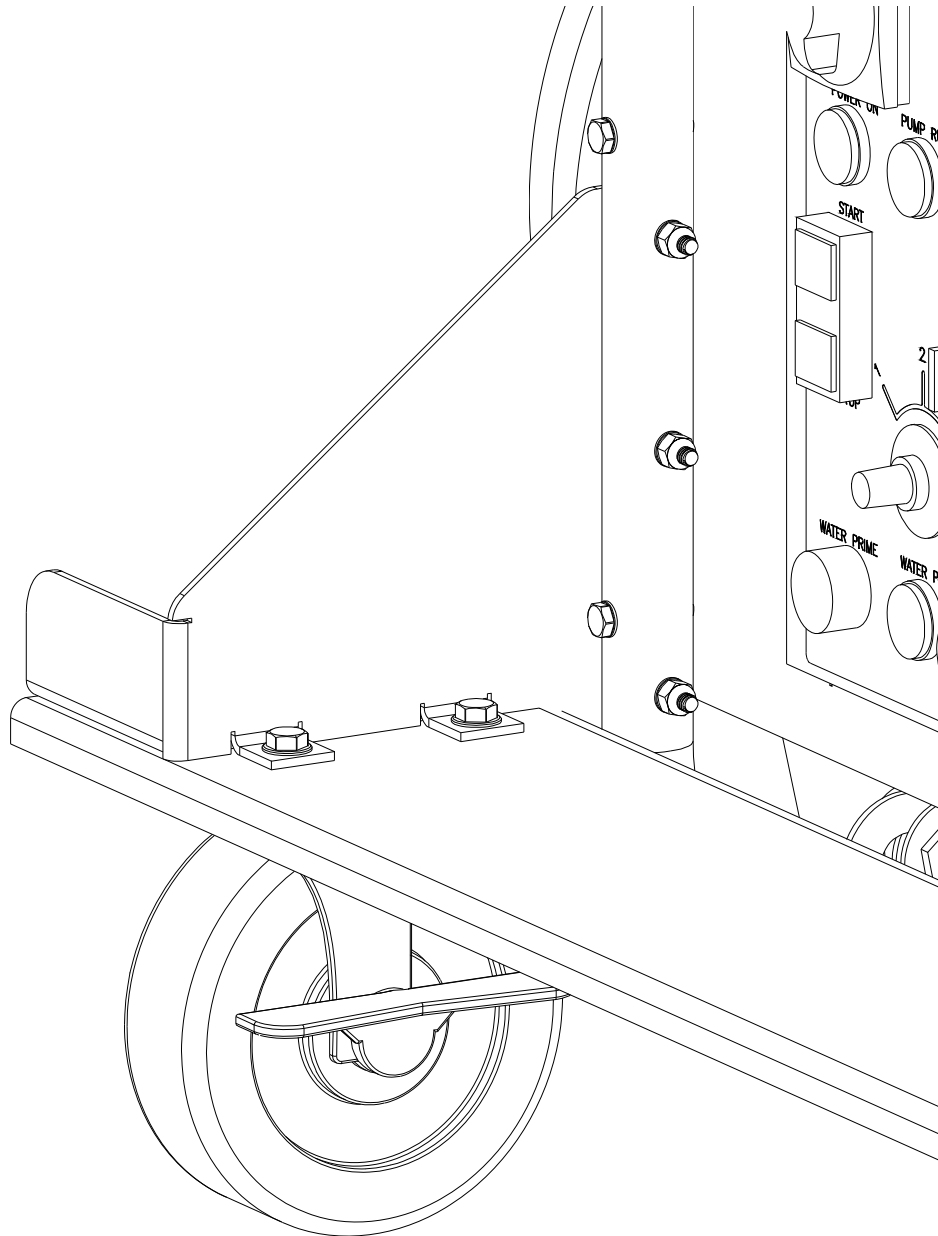

Care must be taken when transporting the machine due to the minimal clearance between the output connector of the pump and the ground. As the unit is “pushed” the pump connector is the furthestmost point of the machine and thus prone to damage from impact with objects in front of the machine or from the ground itself. The machine must be “eased” up curbs or steps.

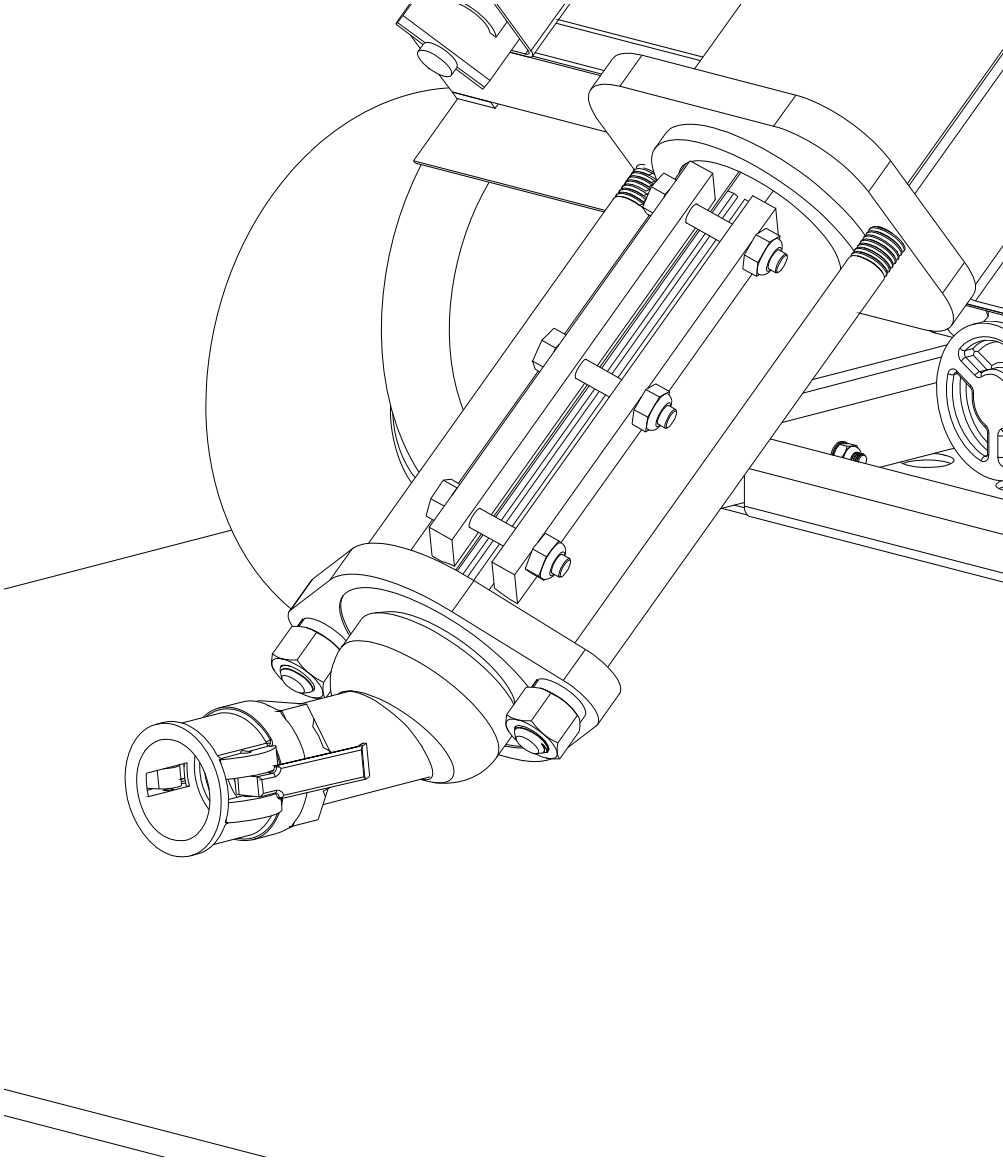

Once the machine has been positioned then the locks on the rear swivel casters should be set.

Pay consideration to water source, power and material locations when setting the machine in position. The site must be flat and level to ensure that the machine operates from a horizontal position.

## Section 4 – Machine set up

### *Unpacking*

Remove the safety grid from the top of the machine by removing the 4 bolts, clips and washers, using the provided 7/16" AF wrench . Keep all parts to be used to replace the grid later.

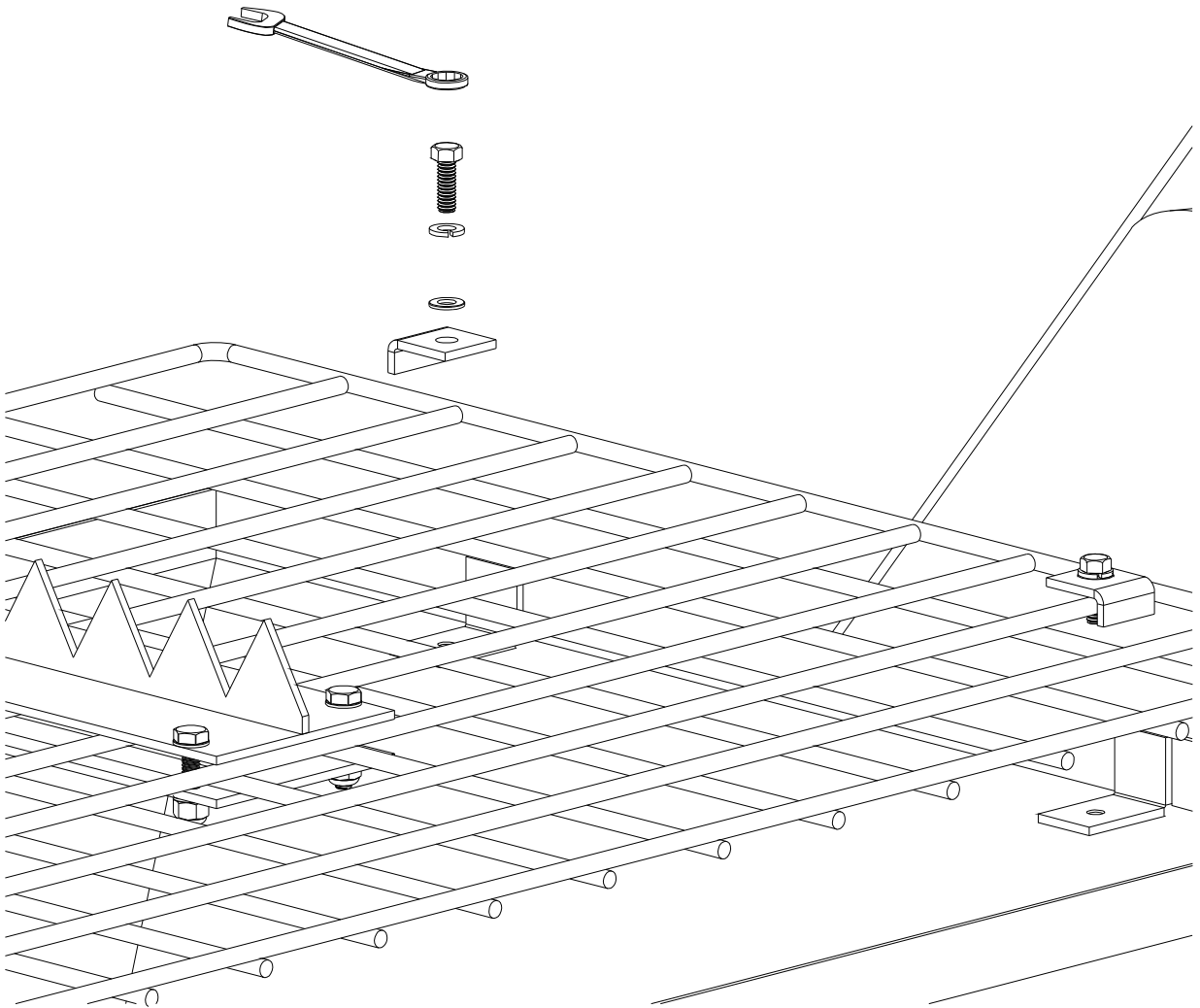

Remove all items from the hopper, excluding the mixing shaft, but including the pressure tester, the power cord and socket assembly, the Quality check sheet and user manual, and the wired remote. Check that the hopper inside is clear of all items except for the mixing shaft..

Consult the final inspection record supplied in the packaging for details of your machine and the items checked prior to shipment. Keep this document for your records.

## ***Machine assembly***

Ensure that the drive shaft is fully engaged in the rotor at the pumping end of the machine. It is essential that the round center guide be in the pilot hole of the rotor and that the lower spar be in the slot.

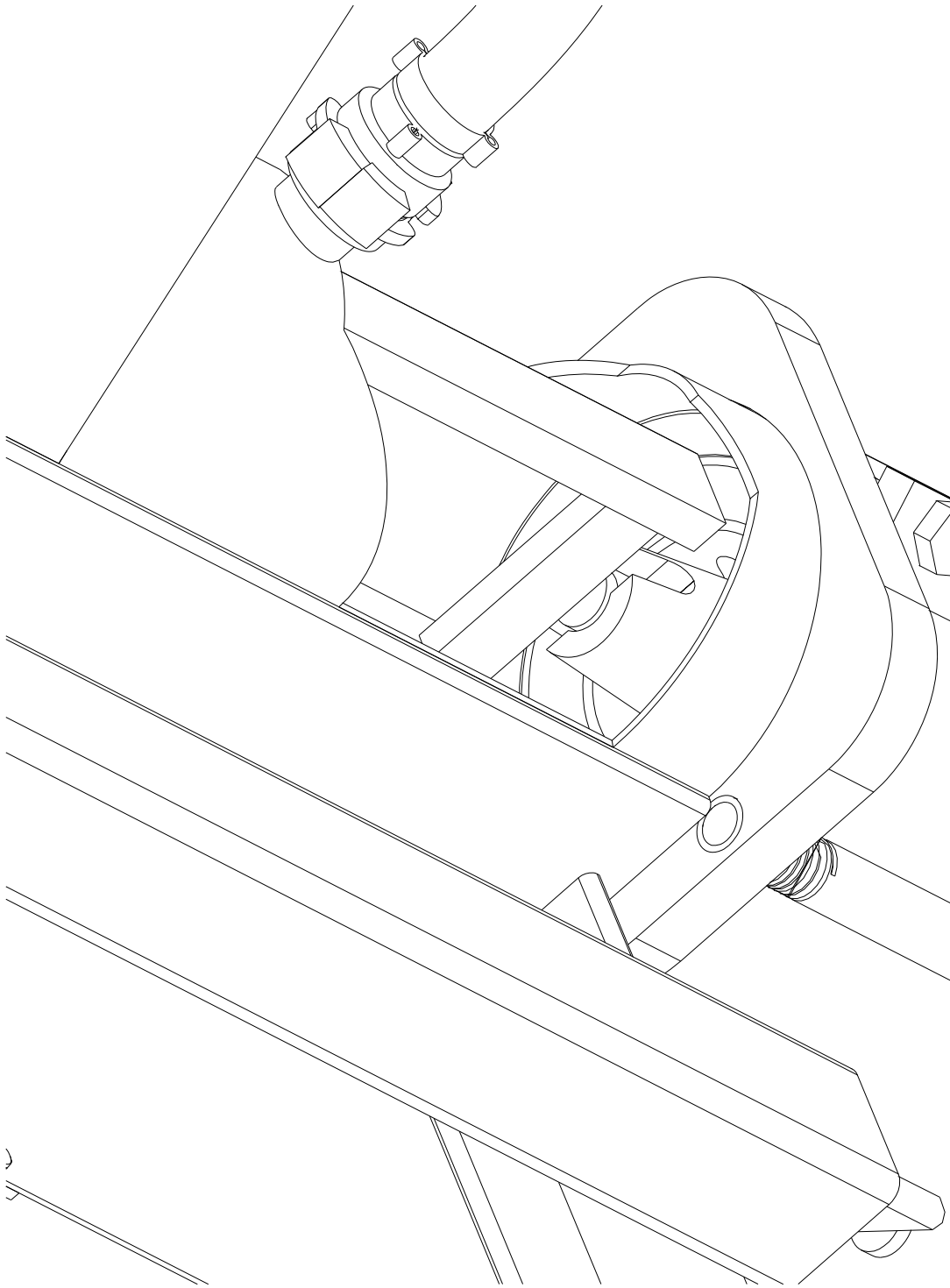

Rotate the motor output shaft and auger drive by hand, or a suitable lever until the flat end of the mixing shaft aligns with the slot in the end of the hauling bracket on the motor.

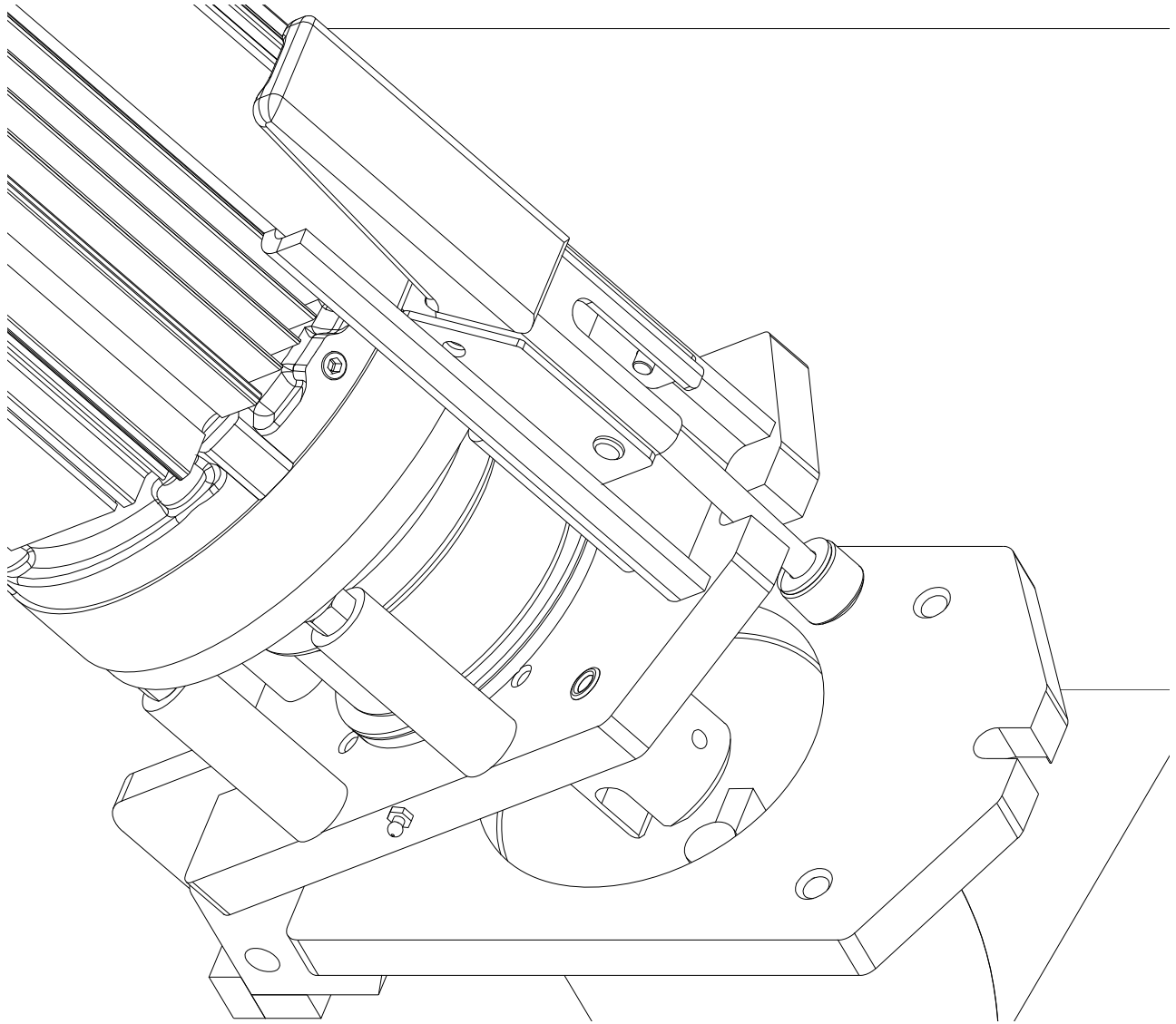

swing the motor assembly into position, checking that the shaft assembles into the slot in the auger drive, and that the location dowels on the motor assembly locate into the pilot holes in the hopper assembly. It maybe necessary to swing with some momentum to enable full closure, if the either the motor or the pump have recently moved position.

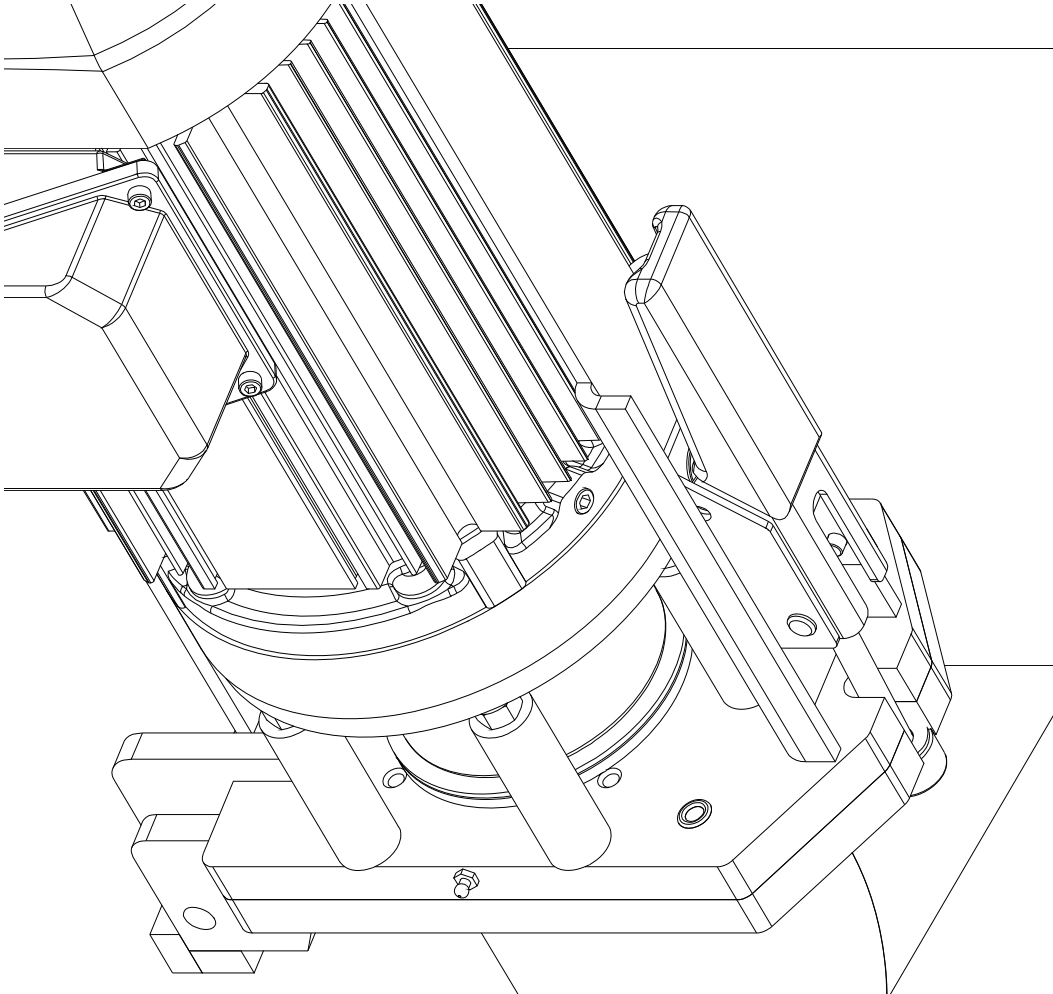

Note: the drive shaft will likely become tight between the two drive slots during static assembly. Once the unit has been running, the compressive force will be reduced or eliminated to within working limits. During pumping the compression will be present, during reverse the compression will be relieved.

If full closure cannot be achieved with reasonable force, then replace the safety grid with all fasteners in place and the clamp held shut as far as possible, then briefly “jog” the motor using the stop start switch and the water pressure bypass fitted, and the motor assembly will close to fully shut.

### **Important**

Replace the safety grid back onto the top of the hopper and secure using the 4 clips, bolts and washers. Operation of this machinery without the grid in place is prohibited.

### ***Electrical connections.***

To be carried out by a licensed / qualified electrician.

1. Ensure that there are no power connections to the Electronic drive module.
2. Site the machine within 50 feet of the power source.
3. Obtain the power cord (supplied with the machine) 3 core for single-phase 220VAC and 4 core for 3 phase. The power source must be 208 -240VAC, and capable of supplying 30A Min on each leg / phase. 45-60A is the recommended level to avoid nuisance tripping at high loads. Turn the breakers OFF in the power source distribution box, and remove them from the bus bars to ensure that no voltage exists on the cables.
4. Make the connection between the power cord and the main distribution box, using the supplied electric cord with plug and your power source. Ensure that the Earth is connected.
5. Connect the plug to the machine, and ensure that the drive module rotary isolator switch is turned OFF.
6. Replace the breakers into the distribution box, onto the bus bar and turn them ON.
7. Turn the machine's drive module isolator to ON, and listen for the cooling fan to turn on, and the "system power" light to illuminate. (when using the 3-phase machine, the water pump may run in the reverse direction changing the position of the "run off run" switch, which reverses the phases. Pump direction is shown on the front casting, clockwise looking from the fan end, but a flow increase through the water indicates correct rotation)



## ***Pre-run setting and test***

The following must be conducted by a supervisor or a qualified individual experienced in electro-mechanical equipment.

Ensure that there are no persons close to the machine.

Ensure that there are no obstructions in or around the machine.

Turn the speed selection knob to speed 1.

8. Attach a suitable water feed – (see note) hose to the machine using the “Geka” style hose tail supplied, and turn the water on at the spigot.

Note – the water feed must be able to support 4GPM @ 40 PSI or 7GPM @ 40PSI MINIMUM.

9. Press the “water prime” button for a couple of seconds, to expel air from the hosepipe and to allow some water into the mixing chamber of the machine. (The lower plug can be removed and be used as a “level”. Once water flow from the lower port, the prime button should be released and the port plug replaced.

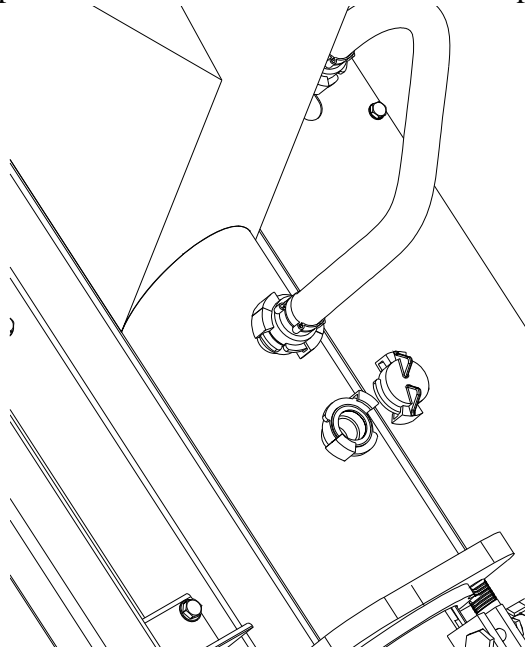

10. Press the **START** button and observe the machine to turn the drive shaft and in turn the pump unit. **PRESS THE STOP** button,
11. Turn the direction switch from **FWD** to **REV**, and hold in position, as it is spring returned, to prevent excessive reverse running.
12. Press the start button and observe the machine to turn the drive shaft and in turn the pump unit, in reverse. **PRESS THE STOP** button within 5 seconds, or damage will result to the pump unit.

**Note** It maybe necessary to try reverse prior to forwards as this often take less power than forwards when initially breaking free a rotor unit.

13. The machine is now ready for use, by trained and qualified operators.

## Section 5 – Machine operation / stator pressure setting

The following are to be completed by trained and experienced persons, familiar with the pumping system provided.

1. Connect the pressure tester to the output coupler on the end of the pump unit, with its flow valve OPEN.

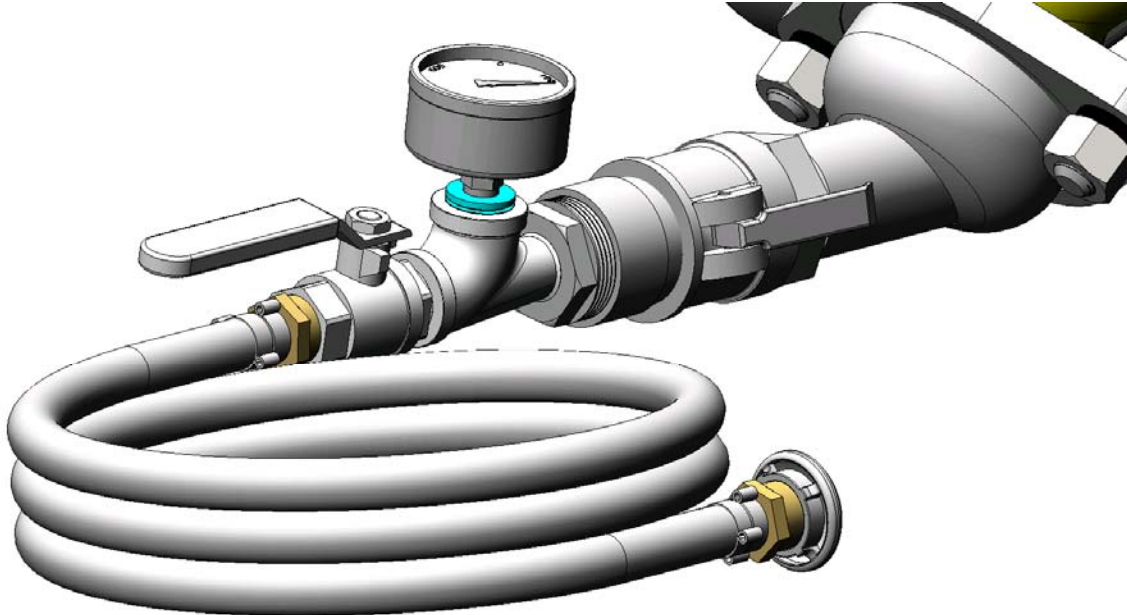

2. Fill, up to the lower mixing chamber port of the MP-25 hopper with water using the prime button, and also set the flow meter flow to suit the your material. For this pressure calibration only, add a couple of squirts of a suitable lubricant, such as dish soap.
3. Connect the pressure switch to the drive module.
4. Turn the water pump on by pressing the water pump button
5. Turn on the machine in the FWD direction and observe fluid to be displaced from the pump through the pressure tester.
6. Increase the speed of the machine to your chosen setting (typically speed 2), and slowly close the valve on the pressure tester, and observe the pressure to increase. Adjust, if necessary, the clamping force on the stator to achieve your chosen pumping pressure. Too much pressure will wear out your stator prematurely, too little will not give you your optimum output for the RPM chosen.

Keep the pump run time to a minimum during pressure setting to maintain the life of the stator.

7. Once the pressure has been set by adjusting, evenly, the bolts, stop the machine, open the pressure tester valve fully, and disconnect from the coupler.
8. Turn OFF the water pump.

**NEVER** allow the water pump to operate with no flow for more than 5 minutes as the water can become overheated and provide a hazard and or damage to the pump.

***Ideal set up method, to be amended to suit your actual application.***

The rotor stator pump is a positive displacement, progressive cavity pump, the positive displacement aspect being controlled by the clamping tension on the stator.

1. Adjust the stator to have minimal tension.
2. Place the desired length of hose on the pump unit, and elevate, if required to suit your actual discharge height, complete with any output device fitted.
3. Set your water flow rate to the recommended reading
4. Start the machine at your chosen speed with just water and a small amount of dish soap running through the machine.
5. Measure the flow of output at the discharge point
6. Progressively and evenly tighten the clamp on the stator until no more output is achieved.
7. Stop the machine.
8. Remove the output hose, and connect the pressure tester
9. Turn on the machine, close the pressure tester valve and note the pressure. This is the pressure you require to set the rotor stator to, to pump at your required rate.

**Note.** Actual material will typically produce higher pressures and lower flow rates, and will require some experimentation, but this method will provide a good approximation

Excessive clamping force just generates more heat more wear, higher energy consumption and a high potential damage in the event of a plugged hose, blockage or other emergency.

A general and typical stator pressure setting with water is 300PSI, which will meet most applications.

## *General notes for operation*

- Check that the supply voltage is correct for the unit to be operated.
- Check that the required phase configuration is correct for the machine to be operated
- Grease auger drive seal daily, with water resistant, corrosion inhibiting grease.
- For starting the pump, Ensure that the speed control is at selection 1.
- Turn main power switch on.
- Prime the mixing chamber with water.
- Start the water pump.
- Push start button, and prime the hoses and wet out the system while setting the water flow rate.
- Adjust speed to desired output.
- To stop machine push the stop button.
- If a hose plugs while pumping, reverse the direction on pump to relieve line pressure. Note – The water flow solenoid does not operate in reverse..
- Never point hose towards personnel when pump is working.
- Stop and clean the machine every 2 hours until experience is gained with your material.
- When cleaning the pump, do not remove grate while pump is running. Wash out hopper with water and let it run out of the hose. When the hopper and mixing chamber is clean, run foam balls through hose with clean water. Do not spray water on or in control box. Control box should be wiped down with a damp rag. Remove the mixing shaft and clean off ALL material
- If access is required in to the hopper, disconnect power source before removing grate. Motor can be “swung” out of the way, this facilitates easier final clean up.
- Mixing Pump is supplied with an adjustable stator. The sleeve can be tightened to bring working pressure back to normal range as the stator wears down. This should be done in small increments. Over tightening the stator will cause premature wear and heat up material.
- Always check hoses and cords for wear.
- If excessive material is allowed to build up the output of the machine will decrease, if cleaning with water does not remove all material from with the mixing chamber, then the clean out shaft should be employed. (See simple maintenance)
- The unit runs on high voltage and is capable of high pressures in the hoses.
- NEVER spray water under the machine under the fan shroud, or water will enter the drive module and damage the components is side

## Section 6 – Simple maintenance

The MP-25 mixing pump unit is very simple to maintain.

By far the biggest part of maintenance of the MP-25 machine is cleaning during and after a job. Failure to clean properly after use will damage seals, paint, and moving parts due to material build up causing wear.

Pay particular attention, when cleaning, to the material build up inside the mixing tube, around and on the mixing shaft. Pay attention to the seal around the auger drive / hauling bracket fixed to the drive shaft at the rear of the machine.

DO NOT spray water inside the fan shroud or direct the jet towards the shroud or water can get into the drive module and damage electrical parts.

Prior each clean down, the drive module should be disconnected from the power.

After each clean down the drive module should be opened, and ANY moisture or debris removed with a soft towel then compressed air. DO NOT blow the water or debris into the components.

Ensure that the seal between the hauling bracket and the motor is greased each day, with a water resistant, corrosion inhibiting grease. Grease until a small amount of grease can be seen “oozing” from around the hauling bracket. If there is grease in the seal then material cannot get in!

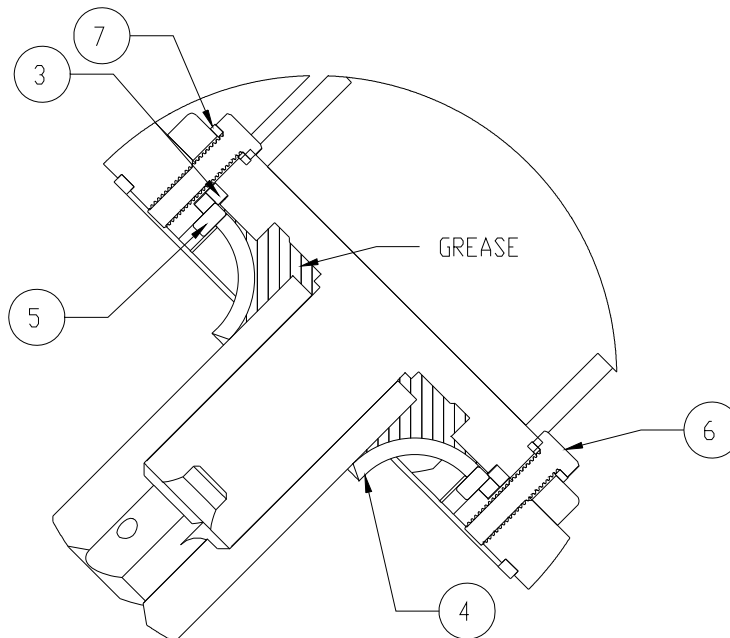

## *Clean out shaft – using*

1. The clean out shaft should only be used in the event that normal cleaning practices do not remove all the material from the job.
2. The clean out shaft can cause significant damage if used incorrectly.
3. The clean out shaft is designed to be used on fresh material, that cannot be removed using normal wash down and manual means.
4. The clean out shaft will become damaged if trying to clean out fully cured and hardened material.
5. The clean out shaft is to be turned at the lowest speed, with plenty of running water, as any debris created will be passed through the stator and the water will minimize any damage.
6. The clean out shaft is loaded into the machine in the same manner as the mixing shaft. While the shaft is turning the cutter head will self-feed into the mixing chamber cleaning material from the sides as it descends. It will automatically stop feeding when it reaches the end of its travel, limited by two areas of weld on the shaft.
7. Do not use the clean out shaft without the safety grid fitted.

ITEM NO.	QTY.	PART NO.	DESCRIPTION
1	1	60010127	ASSY,CLEAN OUT CORE
2	1	60010128	ASSY,DRIVE CLEAN OUT

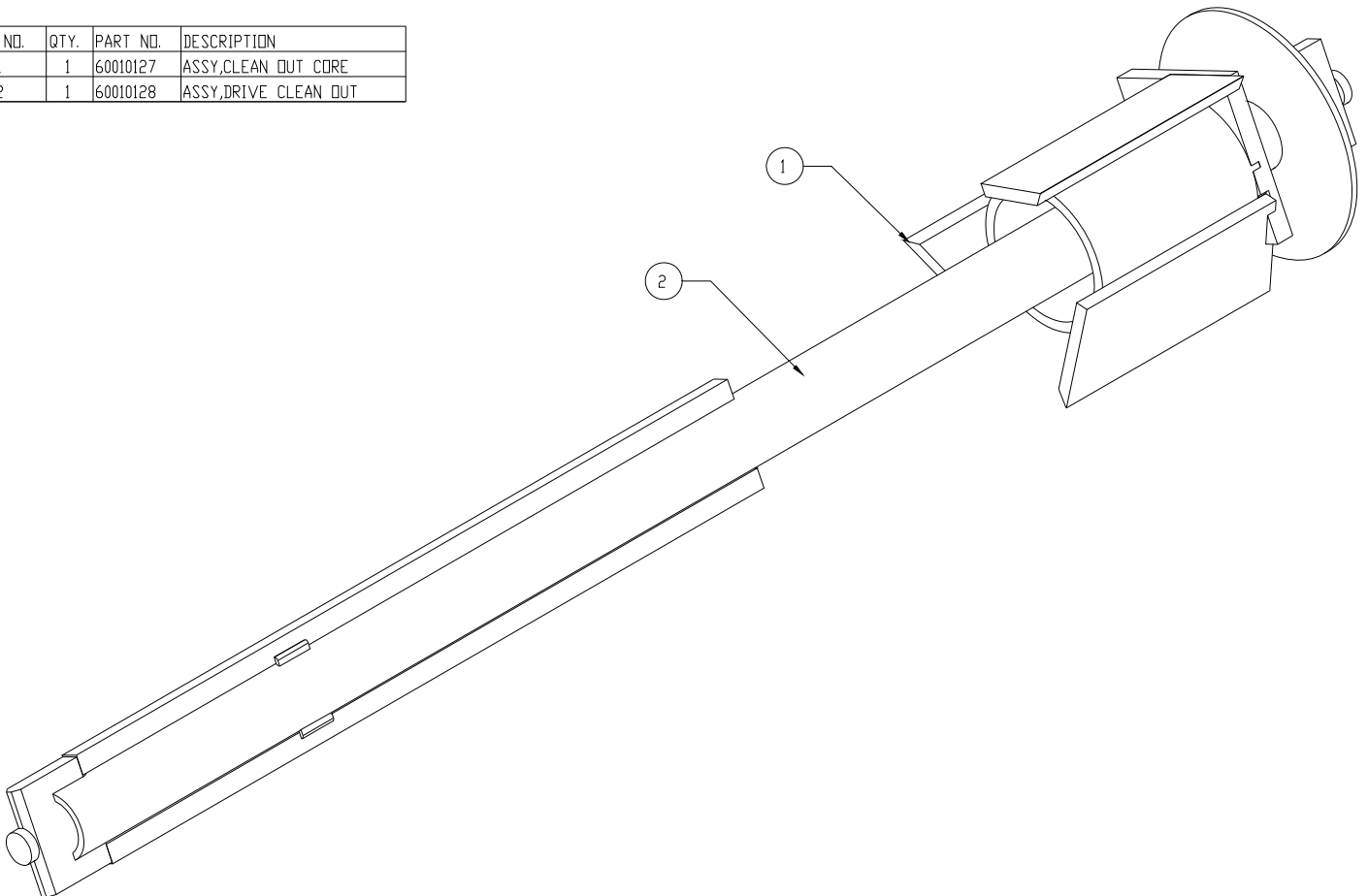

## Section 7 – Additional Notes

### *Wear issues*

A screw pump can only work reliably if there is adequate and appropriate lubrication. The lubricant produces sliding friction between the rotor and the stator. If this lubricating film is damaged, high temperatures are reached and the elastomer wears within a very short time. Even if dry running lasts only a few seconds with new parts, the effect resembles that of a wheel spin on a car tire, dramatically affecting length of service.

### *Winterizing and extended periods or storage*

Connect the machine to correct power source and turn main power ON

Disconnect any water feed hose to the machine.

Remove, using a twisting motion, the water pipe from the water pump to the rest of the system and place / hold the pipe in a position close to the ground and lower than the rest of the system.

Loosen the drain petcock on the rear of the water system

Fully open the water flow meter

Latch open the wash down water spray gun using the built in metal “latch”

Press and hold the water prime button (an audible click will be heard when operated”

Keep holding the prime button in until water has stopped draining from all openings, then release.

Press the water pump run button to turn the water pump on, leave running for approx 15 seconds **Caution** – water will spray out of the water pump in the direction of the disconnected water system pipe. ALTERNATELY instead of running the water pump, compressed air can be blown into the water pump ports to expel standing water.

Turn off the machine and remove the power feed into the machine

Leave all pipes and drains cocks open until next required use.

Ensure that the motor has been fully greased through the grease port.

Ensure that the machine has been thoroughly cleaned and is free from mixed materials

***Start up after extended period of storage.***

Close all pet cocks, reconnect water pipes, close the flow meter, release and close the wash down spray gun.

Connect power to the machine, and turn on.

Connect a water feed to the water pump inlet

Press the water pump switch to turn on the water pump and observe operation. If the motor fails to run and “buzzes” then turn off the water pump, and using a suitable wrench loosen the 3 bolts on the end cap of the pump head by approx 2 turns. Insert a suitable flat blade screw driver into the provided slots between the end cap and the pump head and lightly “lever” on both sides until the cover lifts from the pump head. Restart the pump, observe operation and while running retighten the 3 bolts until tight.

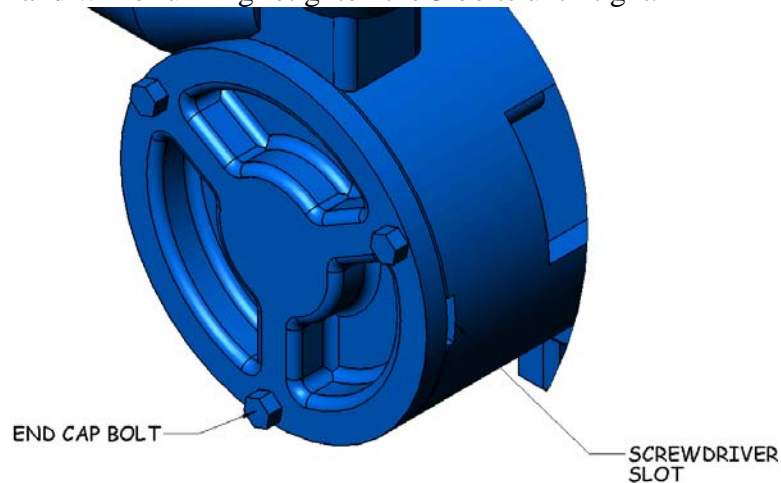

Turn off the water pump

Press the prime button and observe a “click” then slowly loosen the flow meter adjusting knob until water can be seen running, release the prime button and observe the water to stop.

The machine should now be ready for immediate use.





## LIMITED WARRANTY POLICY

Machine Technologies warrants each of its new machines to be free of defects in material and workmanship under normal use and services for a period of one (1) year from the date of delivery.

The warranty is issued **ONLY** to the **INITIAL USER**. The warranty period begins when the product is delivered to the initial user or when first put into service, whichever occurs first. Said warranty is void if the machine is subject to misuse, neglect, accident or abuse.

Machine Technologies' obligation under this warranty is limited to correcting without charge, at its warehouse, any parts or parts thereof which shall be returned to its warehouse, transportation/shipping prepaid and upon Machine Technologies' examination proves to have been originally defective. Correction of such defects by repair or replacement shall constitute fulfillment of all obligations to the initial user. This warranty does not include labor or transportation charges unless specifically identified and authorized in writing by Machine Technologies. Nor does the warranty apply to any unit upon which repairs or unauthorized alterations have been made.

The warranty does not apply to normal maintenance service or to normal replacement of certain machine parts which are subject to normal wear (including but not limited to pins, bushings, rotors, stators, hoses, spray caps, spray nozzles, mixing shafts, shaft couplings and connectors, dosing shafts, pump shafts, filter elements and tires).

**THIS IS A LIMITED WARRANTY AND IS IN LIEU OF ANY OTHER WARRANTIES, EXPRESSED OR IMPLIED, INCLUDING ANY WARRANTY OF MERCHANTABILITY OF FITNESS FOR A PARTICULAR PURPOSE.** In no event shall Machine Technologies be made liable for incidental, general or consequential damage, loss or any expense directly or indirectly related and resulting from use or lack of use caused by delay in delivery, parts failure, or any other causes associated with the product use. No person, firm or corporation is authorized to assume for Machine Technologies any other liability in connection with the sale of Machine Technologies products.