



## Gusto 120 Oven Assembly and Operation Manual

The Stone Bake Oven Company  
Units 18 + 19  
Christchurch Business Park  
The Runway  
Christchurch, Dorset  
BH23 4FL

[info@stoneovencompany.co.uk](mailto:info@stoneovencompany.co.uk)

For further information, printable manuals, our favourite recipes and more,  
visit us at [www.thestonebakeovencompany.co.uk](http://www.thestonebakeovencompany.co.uk)

© The Stone Bake Oven Company 2015. All rights reserved.

## **FIRE AND SAFETY NOTICE: SAVE THESE INSTRUCTIONS**

Failure to follow the Gusto Oven Manual and Health and Safety instructions may result in oven damage, cause damage to property, cause bodily injuries or in some cases even cause death.

If you choose to use the oven, it is done so at your own risk. No liability is accepted by The Stone Bake Oven Company for any injury, damage or loss incurred.

DO NOT burn flammable liquids or similar at any time in the oven, including but not limited to; firelighter fluid, petrol, diesel, lantern oil or kerosene.

DO NOT artificially attempt to induce airflow through the oven, e.g. using a fan.

ONLY USE untreated dry hardwood as a fuel and DO NOT burn any refuse, plastics, treated wood; including laminates, charcoal, chipped wood, pressure treated lumber, sappy wood (for example, pine) or fossil fuels.

**ALWAYS WEAR PROTECTIVE CLOTHING:** We strongly recommend gloves for use during oven operation. ALWAYS keep children, groups of people and pets a safe distance from the oven whilst in operation and whilst cooling.

ENSURE all tools and materials used in the oven are appropriate for high temperatures and take care whilst handling tools. No liability is accepted for any injury, damage or loss that occurs because non-approved tools have been used.

BEWARE of high temperatures achieved on the outside and inside of the oven and be cautious of flying sparks. Ensure wood storage is covered by a non-combustible material. Do not leave the oven unattended.

ENSURE if you install your oven and flue indoors/under cover the appropriate building regulations and safety restrictions are met. Check with your local authority.

DO NOT keep any combustible materials, near or within range of the oven at any time. This includes clothing, furniture, electrics, nearby shrubs or trees, flammable materials, liquids or the like.

DO NOT touch the oven or flue, or artificially block or cover the oven entrance at any time during and after operation.

DISPOSE of ashes in a safe way once they are cold. Ensure you regularly clean your flue parts, failure to do so may result in flue fires.

DO NOT modify the oven in any way from the manufacturer's design and specification. "Building in" as detailed by The Stone Bake Oven Company Build Manuals does not count as a modification.

### **FIRE PRECAUTION:**

Ensure a water fire extinguisher of at least 9 litres capacity (to deal with the oven and surrounding area) and a bucket of sand are positioned within easy reach. Although we have tested the use of fire extinguishers on the oven with no adverse effect, in case of an emergency, we recommend only sand is used to knock down a fire within the oven. In order to satisfy UK Fire Safety Legislation we strongly suggest that anyone who may tackle a fire should be adequately trained by a fire safety professional.

# Contents

## 1. About your Gusto 120 Oven

- 1.1 Gusto Oven finish
- 1.2 Soot
- 1.3 If your Gusto Oven chips/cracks
- 1.4 Gusto Oven reinforcement fibres
- 1.5 Gusto Oven maintenance

## 2. Gusto 120 Oven assembly

- 2.1 Gusto Oven and Flue Clearances
- 2.2 Gusto Oven Delivery
- 2.3 Gusto Oven Location
- 2.4 Gusto Oven Installation
- 2.5 Gusto Oven Assembly

## 3. Gusto 120 Oven use

- 3.1 The 'don'ts' when using your Gusto Oven
- 3.2 What wood to use in your Gusto Oven
- 3.3 How to make fire
  - 3.3.1 Lighting your oven for the first time / in Autumn and Winter
- 3.4 How to cook in your Gusto Oven
- 3.5 How to dispose of ashes safely
- 3.6 Oven tools

## 4. Gusto 120 Oven warranty



# 1. About your Gusto 120 Oven

Congratulations, you are now the owner of your own, registered design Gusto 120 Oven by The Stone Bake Oven Company.

## Your Gusto 120 Oven:

- Has Micro-Mesh reinforcement
- Is hand cast in the UK

**!** Before using the oven, follow all the Gusto Manual installation steps, check that there are no obvious defects in the oven and that the safety information has been read and understood by anyone using the oven. Failure to do so may void the oven warranty.

**TOP TIP:** To get the very most from your oven, be sure to check out the [online cooking techniques guide](#) and our free recipes at [www.thestonebakeovencompany.co.uk](http://www.thestonebakeovencompany.co.uk)



## 1.1 Gusto Oven finish

Due to the nature of the materials used to make your oven and the hand casting process, natural variations between ovens is expected. From variations in colour, minor pitting in the oven surface to surface chipping. Here at The Stone Bake Oven Company, we believe each oven is unique, adding to its rustic and individual charm.

## 1.2 Soot

After the first use, your oven may become blackened in parts. This is due to soot accumulation and is a normal expectation of any wood fired oven.

## 1.3 If your Gusto Oven chips/cracks

Take care when maneuvering your Gusto Oven, as slight chipping may occur. If chipping does occur, simply ask the Stone Bake team for a patch kit if needed or you may find that the build process conceals the chipping.

Due to the expansion and contraction of the oven during operation, the appearance of hairline cracks, visible during and after operation inside or outside your oven is expected. This is a normal expectation of any wood fired oven. This WILL NOT affect the longevity and effectiveness of your Stone Bake oven.

## 1.4 Gusto Oven reinforcement fibres

On very rare occasions, there is potential for fine metal fibres to protrude from the oven base or dome. Please take care and wear gloves when maneuvering the oven. If needed, these fibres can simply be removed or trimmed away.

## 1.5 Gusto Oven maintenance

Great! A self-cleaning oven! The Gusto 120 boasts very little cleaning and maintenance. All spilled or stuck on food will be burnt off by the heat achieved within the oven. Simply remove the ashes before the next firing in a safe way (see section 3.5).

**!** Ensure you regularly clean your Gusto Oven flue. Failure to do so may result in a flue fire.

# 2. Gusto 120 Oven Assembly

## 2.1 Gusto Oven and Flue clearances

**!** Oven clearances are recommended for your safety and the safety of your property. It is essential that these clearances are maintained from any combustible materials, failure to do so may result in fire.

If the Gusto 120 is installed to meet The Stone Bake Oven Company specifications, oven clearances are 100mm from all walls of the oven and 900mm from the flue length. Ensure nothing obstructs the flue from directly above.

## 2.2 Gusto Oven Delivery

The oven weighs approx 420kg in total; the 4 x base pieces weigh approx 150kg in total and the 4 x dome pieces weigh approx 270kg in total. Each oven piece is designed to be manageable to lift with 2-3 strong adults who are trained in lifting techniques. Take care when lifting and assembling the pieces.

Included in the Gusto 120 package: The Gusto 120 Oven, Gusto Oven door, flue length, rain cap, high heat refractory insulating blanket, calcium silicate insulating board, high heat fire cement and a decorative archway.

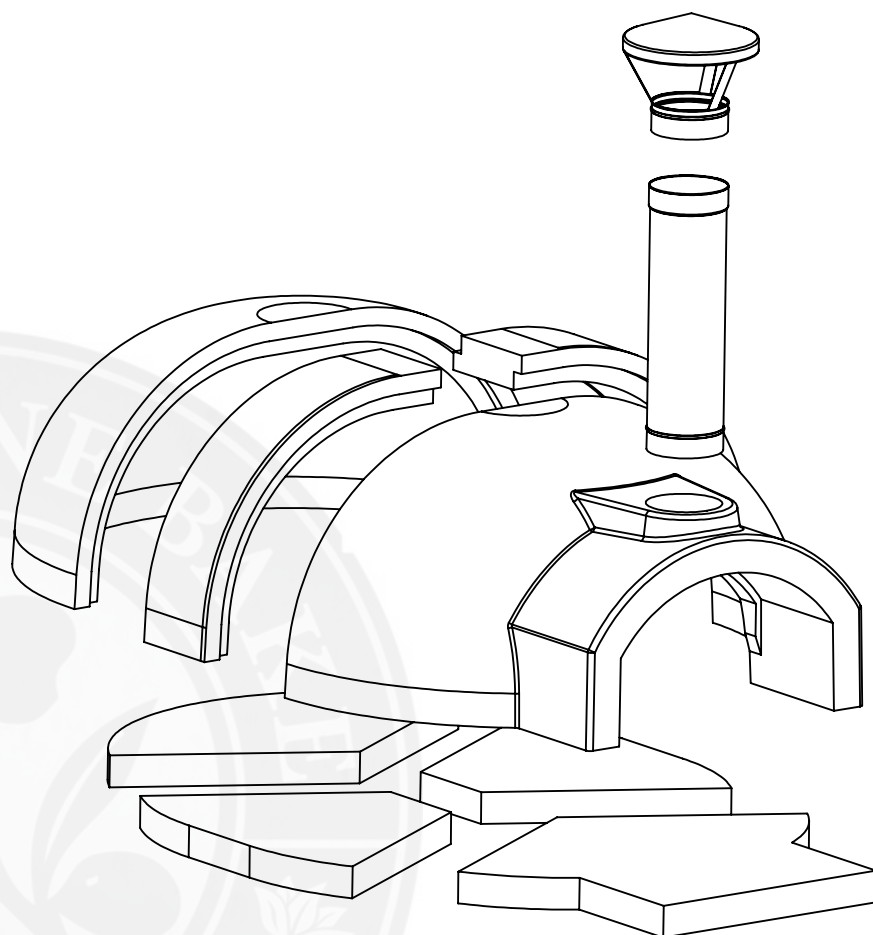
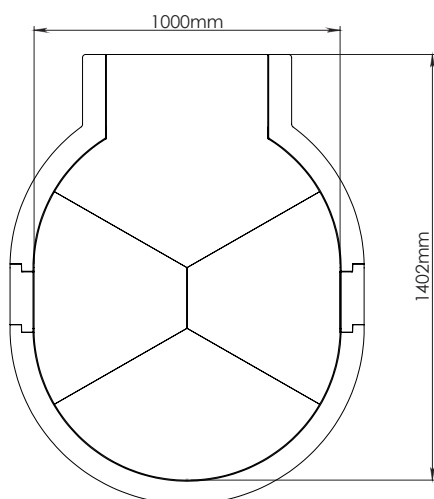
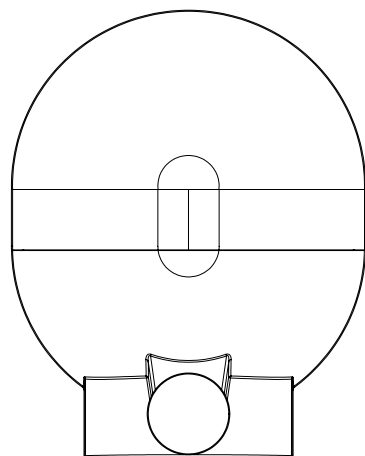
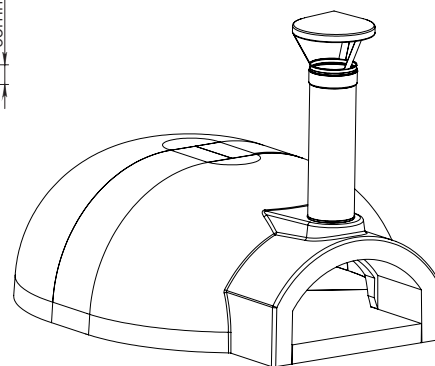
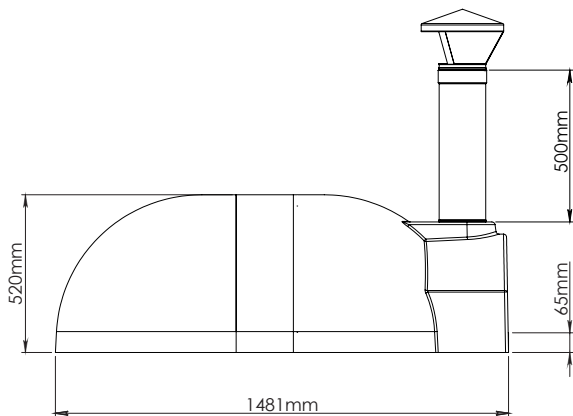
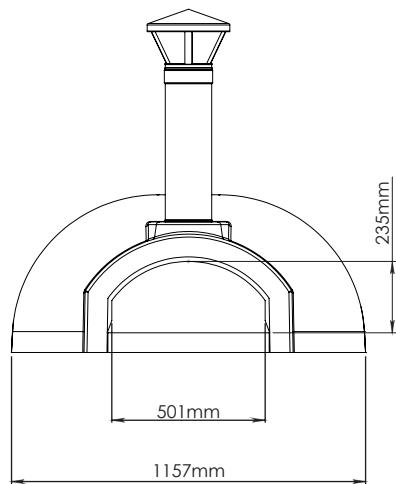

## 2.3 Gusto Oven Location:

Ensure the oven is in a sheltered location, taking common wind direction and drafts into consideration. If you are installing it under cover/indoors the appropriate measures to meet fire regulations, local restrictions/laws and health and safety measures must be under taken. The Stone Bake Oven Company do not accept any liability where these or similar measures have not been met.

## 2.4 Gusto Oven Installation

The Gusto 120 Oven can be installed in a range of different designs using different materials. For inspiration, why not visit our website Gallery for design ideas to suit your home or garden. For build manuals on how to build a base and enclosure for the Gusto Oven, contact the Stone Bake team or visit the 'Manuals and Videos' section on our website.

## 2.5 Gusto Oven Assembly

! Note: wear protective mask and goggles when cutting insulation board and using insulation wool.

! DO NOT place fire cement between the oven base joints, this will affect its ability to fit together.

! Heavy: The oven dome and base parts are heavy and fragile, handle with extreme care when moving to prevent oven chipping.

! We recommend anyone lifting the oven is adequately trained in lifting techniques. Lift the oven pieces with two or more people.

! To ensure the oven floor is installed level, you can bed under the base pieces using sand or fire cement for a level finish.

! Keep fingers and clothing clear from oven base and joints during set down and assembly.

After building your oven base to The Stone Bake Oven Company's build manual instruction, lay your insulation board beneath the oven to cover the footprint of the oven floor. You may trim excess board using a saw and place these 'cut offs' on the oven floor footprint to fill in any gaps.

With the base of the oven complete and your insulation boards in position, follow the steps below to assemble the oven.

## Laying the oven floor:

**Step 1:** Set down the front floor segment. Notice the front floor segment is the mouth of the oven and a different shape to the other three floor segments. Check the front segment is in desired location and it is level and centralised.

**Step 2:** Set down the two middle floor segments either side of the front segment, then follow by laying the final back base piece. Check the complete oven floor is level and in its final location. Fire cement or sand can be utilised beneath the oven floor segments to ensure the oven floor is level. The oven floor is now laid.

## Setting the oven dome in place:

**!** For those with restricted access for oven assembly, at this stage you can place the back dome segment in position, leaving a 10 cm gap between the dome segment and the adjoining floor segment. Once the oven is in place you can use a ratchet strap to pull the entire dome together. This is done as the back dome segment is the final segment to be put in place to complete the oven.

**Step 3:** See note above for those with limited access to assemble the oven. Place the front oven dome segment into place, ensuring it fits over the floor segment.

**Step 4:** Next, place the two thin dome segments in place behind the front dome segment.

**Step 5:** To complete the dome, place the back dome segment in place and pull the back dome segment forwards to connect all the dome pieces. Ensure to move the dome segments together for a tight fit.

**Step 6:** Once the oven is assembled, use the included fire cement to 'seal' the joint between the four dome segments. See below: Sealing the Oven.

The oven is now ready for insulating and for the archway to be installed. Refer to the build manuals on our 'Manuals and Videos' section of our website or ask the Stone Bake team for assistance.

## Sealing the Oven:

1. Using a damp sponge, generously dab water on the joint lines in the oven dome.
2. Generously apply fire cement to fill the joint lines in the oven dome surface. Do not fill inside the oven.



3. Once the oven is assembled and fire cement is applied, check the seal of the oven by lighting a small fire with two pieces of newspaper. Check for smoke leaks, if so, fire cement the gap to fully close up the seal.

### **Installing the Flue Manifold:**

Different shapes and finishes can be achieved with a flue system, ask The Stone Bake Oven Company team for more details and recommended flue suppliers.

The Gusto Oven takes a 6 inch/150mm flue. Place your flue in the flue hole in the Gusto 120 Oven, this should be a snug fit.

**!** Single Walled Flue Systems are for outdoor installation ONLY, DO NOT install indoors/under awnings/ covers, gazebos or similar. For more information on indoor installation, contact the Stone Bake team.

**!** It is your responsibility to ensure your flue meets government guidelines and is regularly cleaned to reduce the risk of flue fires.

### **Insulating wool:**

Lay the included insulation wool over the oven, ensuring you overlap any joints. DO NOT leave any part of the ovens dome on show. Insulation thickness is dependent on your requirements, with a minimum of one to two layers thick. You may want to add additional insulation wool to your oven dome such as rock wool or loft insulation on top of the provided insulation wool layer.

**TOP TIP:** For an igloo style, follow this step with foil and plasterers lathe/chicken wire and finish with render. For build details, ask for the render instructions, also available on our 'Manuals and Videos' section of our website and see the Stone Bake website for build images.

**TOP TIP:** For brick enclosures, brick around the oven, layer with insulation wool and fill the void with vermiculite for extra insulation. Then build a roof to the oven. For build manuals, ask the Stone Bake team or refer to the 'Manuals and Videos' section of our website.

**!** Note: wear a protective mask and goggles when cutting insulation wool and board.

### **Finishing Your Oven:**

There are many different types of enclosures you can create with a Gusto Oven using different building materials from wood to brick, tiles, render and stone, the options are endless. For more inspiration on build styles for the Gusto Oven, see The Stone Bake Oven Company website:  
[www.thestonebakeovencompany.co.uk](http://www.thestonebakeovencompany.co.uk).

## 3. Using your Gusto Oven

### 3.1 The 'dont's when using your Gusto Oven

- DO NOT use flammable liquids or sappy wood
- DO NOT use treated wood or non-organic firelighters
- DO NOT cover the entrance of the oven
- DO NOT place combustible materials within oven clearances
- DO NOT overfill the oven
- DO NOT use coals in the oven
- DO NOT touch hot surfaces with naked skin
- DO NOT leave the oven unattended whilst in operation

### 3.2 What wood to use in your Gusto Oven

The Stone Bake Oven Company strongly recommend using kiln dried wood (moisture content under 20%) when using your oven. Seasoned wood, green wood or any wood with a moisture content above 20% will cause your oven to smoke and it will struggle to reach high temperatures. If your oven seems to take longer to heat up, longer to cook pizza or seems excessively smokey, contact the Stone Bake team for some tips to ensure the easy firing of your oven.

**TOP TIP:** To 'kiln dry' your own wood, simply place a stack in the oven after cooking one evening. The retained heat will dry your logs. Ensure you have removed all embers before you place the logs in the oven. Do not leave the oven unattended.

### 3.3 How to make a fire

Very soon you will be used to firing up your oven and getting a feel for cooking environments. In the meantime, you can watch our firing up videos, read our cooking techniques guide or purchase a thermometer from our online shop to help you along your way.

**TOP TIP:** The Stone Bake team are always on hand to answer any query.

#### Step 1

Using your kiln dried, non treated wood, chop into chunky kindling lengths of around 10 inches and about 3 inches thick.

**!** Shop bought, ready cut kindling can often be too small for the oven and will not last in the oven resulting in little heat output. Contact the Stone Bake team if you are unsure on your wood size.

Using a natural fire lighter, place it in centre of the oven floor, make a small cross sectioned structure around it using your cut kindling. Light the natural fire lighter.



Place Fire Lighter



Form kindling stack



Light kindling stack

## Step 2

Leave the fire stack to burn in the centre of the oven. This ensures the oven dome and base is saturated with heat evenly. Add to the burning kindling stack. You will start to approach optimum cooking temperatures 450+ degrees celsius. You can tell this by using an infrared thermometer, a floor standing thermometer or when the sooty deposits in the oven diminish.

## Step 3

Once you have reached optimum cooking temperatures, (450+ degrees celsius) you are ready to start the cooking process. Move the embers of the fire to the back or side of the oven, exposing an area to place food, you can do this using the metal pizza peel, and can clear the oven floor using an oven brush or hearth mop.

**TOP TIP:** Always bring your oven up to optimum cooking temperature first, whether you are cooking pizza in a hot oven or roasting and baking in a cooler oven. This ensures the oven is saturated with heat, and will make sure it stays hotter for longer.

**TOP TIP:** Remember to rotate your items to ensure even cooking, also remember to alternate embers on each side of the oven when cooking over long periods to ensure even distribution of heat.

### 3.3.1 Lighting your oven for the first time/ in Autumn and Winter

Your oven may take a little longer to reach optimum temperatures on your first firing. This is normal. This is due to residual moisture in the oven from storage and transit.

In Autumn and Winter during wet weather or low temperatures, ensure you light the oven slow and steady, at a stable rising temperature for over 60+ minutes. Then resume with your regular firing technique.

**!** Failure to light the oven slowly in these instances may cause oven damage and affect your oven warranty.

### **3.4 How to cook in your Gusto Oven:**

The Gusto 120 Oven has the same cooking abilities as all of our wood fired oven range. You can cook virtually anything in a wood fired oven and achieve a range of different cooking techniques. Cook pizza, roast, grill, bake and more using the different phases of heat in the oven. For an easy step-by-step guide, visit our cooking techniques guide, available online with our free recipes. For foodie inspiration visit our Twitter and Facebook page, or get interactive and send in your pictures.

**TOP TIP:** The door provided with your oven can be used for a range of different cooking techniques including roasting and baking. Take care whilst using the oven door, it may get hot.

### **3.5 How to dispose of ashes safely**

Even if it has been over 24 hours since firing, the ashes from your oven can still be a fire risk. Ensure you wait until the oven is definitely cool before attempting to remove the ash. Remove ash with appropriate tools e.g. oven brush and place in a metal bucket with a sealable lid away from combustible materials.

### **3.6 Oven Tools**

To run your oven safely and effectively, it is essential that you use the correct tools. A range of tools are available to purchase on our website from our online store. Ensure all pots and pans used are appropriate for high temperatures. We recommend cast iron pots and pans for cooking in your wood fired oven.



## **4. Gusto 120 Oven Warranty**

### **Gusto 120 Oven warranty**

The Stone Bake Oven Company, producer of wood fired ovens, warrants the Gusto 120 Oven to be free from defects in workmanship and materials for the period of 1 year from the date of delivery.

### **Investigation of claims against warranty**

The Stone Bake Oven Company reserves the right to investigate any/all claims against its warranty's/this warranty, then subsequently decide upon method of settlement.

### **Warranty Qualifications**

The warranty outlined above is subject to accordance with the following qualifications:

- 1) The warranty does not apply to normal wear and tear of the oven or small/ fine cracks which may appear due to the natural expansion and contraction under heat of the oven dome and base.
- 2) The Stone Bake Oven Company Gusto Oven is installed in accordance to the Gusto Installation Instructions, as outlined in The Stone Bake Oven Company manual and complies with local building regulations.
- 3) The Gusto Oven is subject to normal use, as defined by the operational manual. The Stone Bake Oven Company does not warrant the Gusto Oven when any other fuels apart from dry untreated wood is burnt, as this may cause damage to the Gusto Oven.
- 4) This warranty does not apply to cracking after overfilling the oven, or failing to use recommended fuels and/or failing to follow the guidelines of slow firing in autumn and winter.

### **Limitation Liability**

Under this warranty and any other warranty expressed or implied by The Stone Bake Oven Company to the purchaser/s, shall be limited to repair, replacement or refund, subject to warranty qualifications being met as defined above.

In no event shall The Stone Bake Oven Company be responsible or liable for any incidental and consequential damages to property, losses, bodily injuries and the like, caused by defects in it's products. Whether or not such damage is caused by The Stone Bake Oven Company's negligence or such damage is discovered before or after replacement or repair.

### **Dealers and employees have no authority to alter this warranty**

Dealers and The Stone Bake Oven Company employees have no authority to make any warranties or authorise any remedies which are not in accordance, or which are in addition, to those stated above.

### **How to register a claim against the warranty**

In order for a claim against this warranty and for it to be valid, The Stone Bake Oven Company must be notified by telephone 0845 834 0252 or in writing to; The Stone Bake Oven Company, Units 18 + 19, Christchurch Business Park, The Runway, Radar Way, Christchurch, Dorset, BH23 4FL.

Claims should include the description of defect and original date of delivery with copy of original delivery/ advice note. Claims are to be made within 1 year of the advice note and delivery date.

# Notes



# Notes





For further information, printable manuals, our favourite recipes and more,  
visit us at [www.thestonebakeovencompany.co.uk](http://www.thestonebakeovencompany.co.uk)