

CellOx[®] 325

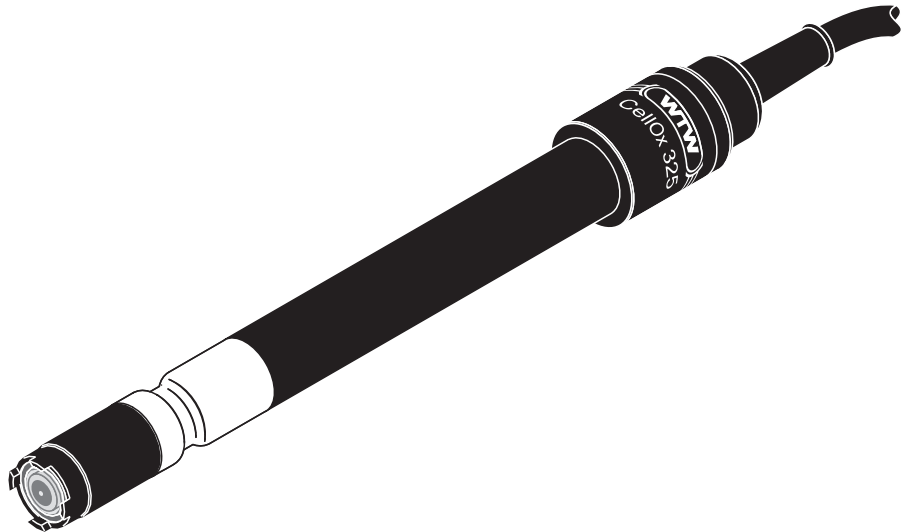

Dissolved Oxygen Sensor

Copyright

© Weilheim 2009, WTW GmbH
Reprinting - even as excerpts - is only allowed with the explicit written
authorization of WTW GmbH, Weilheim.
Printed in Germany.

Contents

1	Overview	20
2	Safety instructions	21
3	Commissioning	21
4	Measuring / Operation	22
4.1	Calibration	22
4.2	Measuring	22
4.3	Storage	22
5	Maintenance, cleaning, replacement	23
5.1	General maintenance notes	23
5.2	Outside cleaning	23
5.3	Changing the electrolyte and membrane cap	24
5.4	Cleaning the electrodes	26
5.5	Checking the sensor for freedom from zero-current	28
5.6	Disposal	28
6	What to do if	29
7	Technical data	30
8	Wear parts and accessories	32

1 Overview

Structure

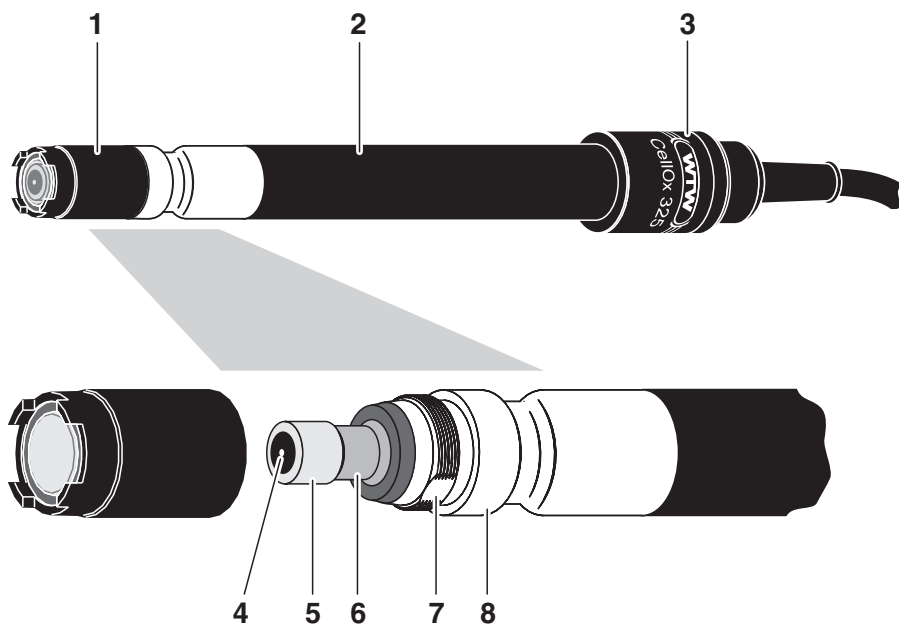

1	WP 90 membrane cap (filled with electrolyte solution)
2	Shaft
3	Connection head
4	Gold working electrode (cathode)
5	Insulator
6	Lead counter electrode (anode)
7	Ventilation area
8	Temperature sensor and auxiliary electrode

Recommended fields of application

- On site measurements in rivers, lakes and wastewater
- Applications in water laboratories
- BOD measurements

2 Safety instructions

This operating manual contains special instructions that must be followed during the operation of the D.O. sensor.

Always keep this operating manual in the vicinity of the sensor.

Special user qualifications

The membrane cap of the D.O. sensor is filled with a small amount of an alkaline electrolyte solution. All maintenance work that requires dealing with the electrolyte solution must only be carried out by persons who know how to safely deal with chemicals.

General safety instructions

The individual chapters of this operating manual use safety labels like the one below to indicate danger:



CAUTION

indicates instructions that must be followed precisely in order to avoid slight injuries or damage to the instrument or the environment.

3 Commissioning

Scope of delivery

- D.O. sensor CellOx[®] 325, filled with electrolyte solution and ready to operate
- Calibration and storage vessel, OxiCal[®]-SL
- ZBK-325 accessory kit, comprising:
 - 3 exchange membrane caps WP-90
 - Electrolyte solution, ELY/G
 - Cleaning solution, RL/G
 - Polishing strip, SF 300
- Operating manual



Note

The membrane cap that is mounted on the sensor for delivery serves mainly as a transport protection. Depending on the duration of the transport and storage period, it may have a shortened operational lifetime. If the measuring system cannot be calibrated (error message of the instrument), please proceed according to section REPLACING THE ELECTROLYTE SOLUTION AND MEMBRANE CAP.

Preparing the sensor for measurement

Connect the sensor to the measuring instrument. The sensor is immediately ready to measure. It is not necessary to polarize the sensor.

4 Measuring / Operation

4.1 Calibration



Note

For calibration, please refer to the operating manual of the measuring instrument.

4.2 Measuring

Note the required minimum depth of immersion and minimum approach flow (see chapter 7 TECHNICAL DATA).

The minimum flow can be provided in different ways, e. g.:

- The flow of the water to be measured is sufficient (aeration tank, water pipe, stream)
- Slowly pull the sensor through the water by hand (lake, container), or
- Use a flow aid such as a magnetic stirrer with stirring device (see chapter 8 WEAR PARTS AND ACCESSORIES)

4.3 Storage

Always store the sensor in the calibration and storage vessel at a temperature in the range 0 ... +50 °C (32 ... 122 °F). Make sure that the sponge in the calibration and storage vessel is always moist.

**OxiCal®-SL
calibration and
storage vessel**

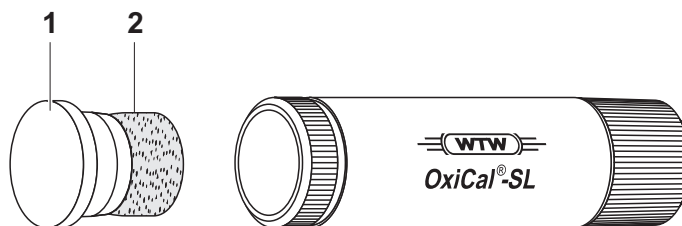

Moisten the sponge:

- Remove the cap (1).
- Take out the sponge (2), wet it, then slightly squeeze it out.
- Insert the sponge again and close the calibration and storage vessel with the lid.

5 Maintenance, cleaning, replacement

5.1 General maintenance notes

For your safety

Note the following safety instructions when handling electrolyte and cleaning solutions:



CAUTION

The ELY/G electrolyte solution and RL-G cleaning solution irritate the eyes and skin. Note the following points when dealing with these solutions:

- During working activities, always wear suitable protective gloves and protective goggles/face shield.
- If it comes into contact with the skin, rinse thoroughly with water and immediately change contaminated clothing.
- If it comes into contact with the eyes, rinse thoroughly with water and consult a doctor.
- Note the safety datasheets.



CAUTION

Before carrying out any maintenance activities, disconnect the sensor from the instrument.



Note

Information on how to order wear parts and maintenance equipment can be found in chapter 8 WEAR PARTS AND ACCESSORIES.

5.2 Outside cleaning

Cleaning agents

Contamination	Cleaning procedure
Lime sediments	Immerse in acetic acid for 1 minute (volume share = 10 %)
Fat/oil	Clean with warm water that contains washing-up liquid

After cleaning, thoroughly rinse with deionized water and recalibrate if necessary.

5.3 Changing the electrolyte and membrane cap



General information

CAUTION

Before starting to work with the sensor, please note the GENERAL MAINTENANCE INSTRUCTIONS on page 23.

WTW delivers the sensor ready to operate (see section 3). The electrolyte solution and membrane cap must only be replaced if:

- a calibration error occurs and the membrane is heavily contaminated
- the membrane is damaged
- the electrolyte solution is exhausted.
- in case of a leak message by the measuring instrument

Changing the electrolyte and membrane cap

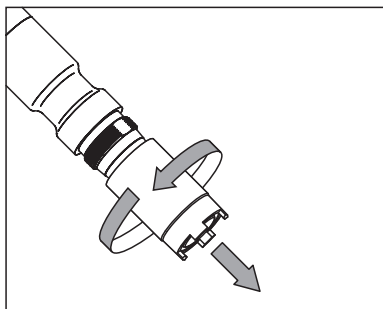

Unscrew the membrane cap.
Caution: Electrolyte solution!
For disposal of the membrane head and electrolyte solution, see section 5.6.

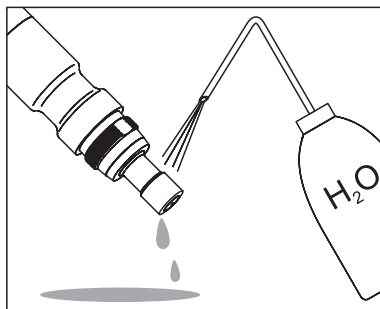

Rinse the sensor head with deionized water.

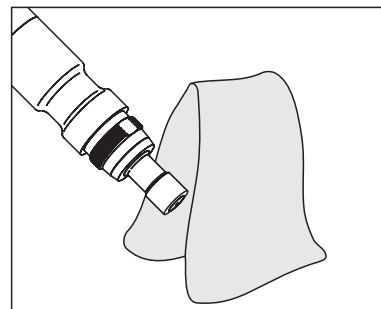

Carefully rub and dry the counter electrode with a lint-free paper towel.

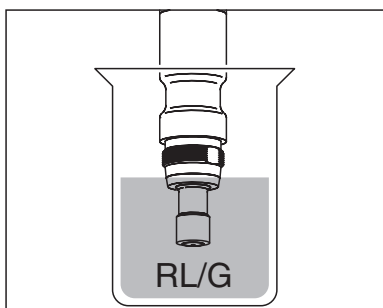

Immerse the sensor head including the counter electrode in RL/G cleaning solution.

Allow to react for 1 to 3 minutes.

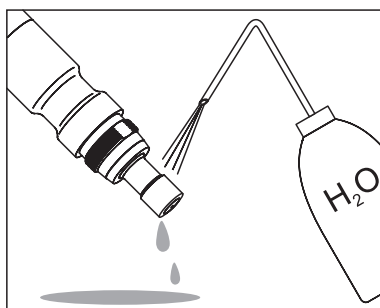

Thoroughly rinse the sensor head with deionized water.

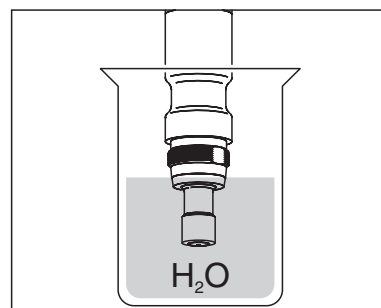

Water the counter electrode in deionized water for at least 10 minutes.

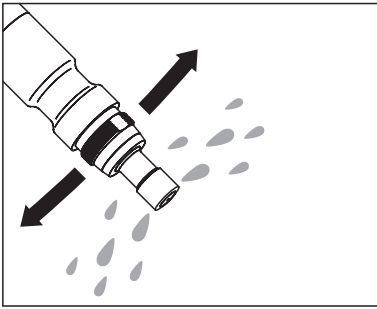

Carefully shake off the drops of water.

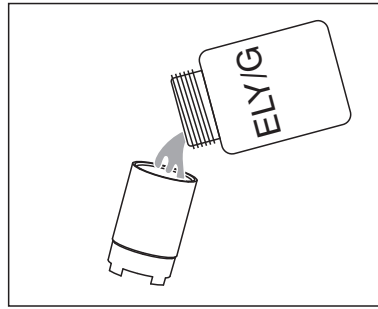

Fill a new membrane cap with ELY/G electrolyte solution.

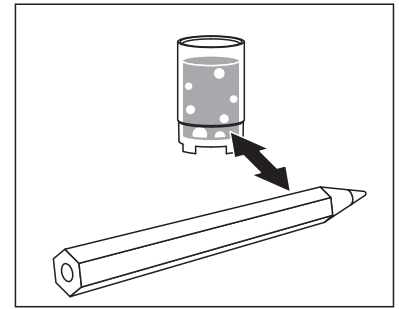

Remove any air bubbles by carefully tapping the membrane head. Additionally, you can prevent air bubbles by throwing the first filling away and refilling the membrane cap.

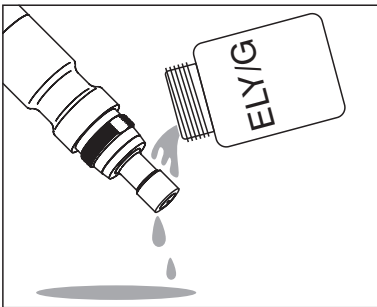

Thoroughly rinse the sensor head with electrolyte solution.

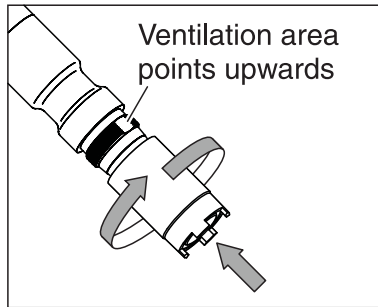

Hold the sensor inclined and screw on the membrane head fingertight using a paper towel. Excess electrolyte solution is forced out of the ventilation area.

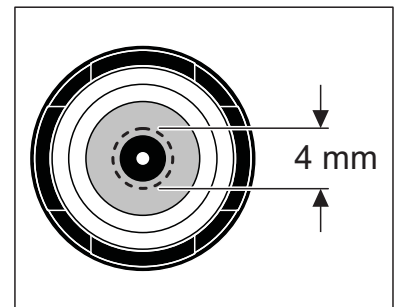

Check the filling: Inspect the face surface. No air bubbles may be present within the dashed circle. Air bubbles outside this area do not interfere.



Readiness to measure

Note

For measurements under high pressure the filling must be completely free of air bubbles.

After approx. 30 to 50 minutes, the sensor is ready for operation. Subsequently calibrate the sensor.



Note

If you want to measure very low oxygen concentrations (< 0.5 % saturation), we recommend to let the sensor rest overnight and then calibrate it.

5.4 Cleaning the electrodes



General information

CAUTION

Before starting to work with the sensor, please note the **GENERAL MAINTENANCE INSTRUCTIONS** on page 23.

Cleaning is only required in cases of slopes too low or too high (sensor cannot be calibrated) that cannot be resolved by changing the membrane head and electrolyte solution.

Cleaning the electrodes

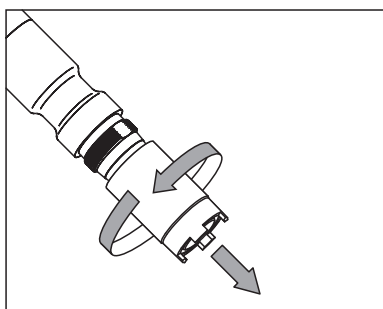

Unscrew the membrane cap.

Caution: Electrolyte solution!
For disposal of the membrane head and electrolyte solution, see section 5.6.

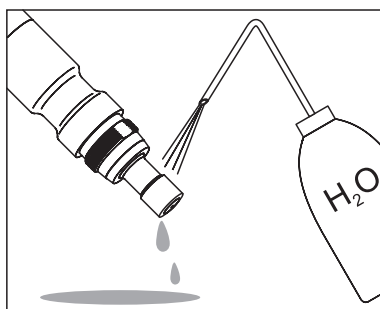

Rinse the sensor head with deionized water.

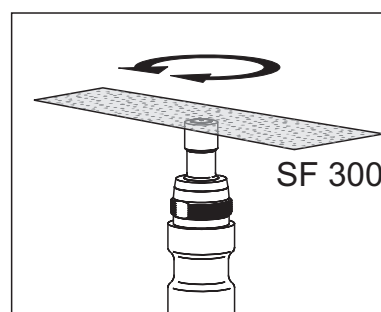

Using the rough side of the **wet SF 300** polishing strip, polish off any contamination from the gold working electrode using light pressure.
Caution: Do not use any conventional sandpaper or glass-fiber brushes.

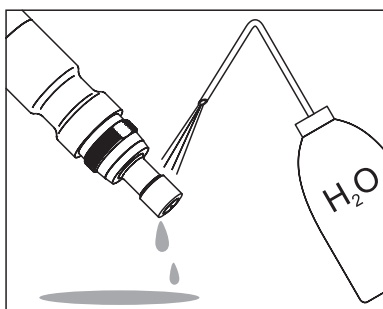

Rinse the sensor head with deionized water.

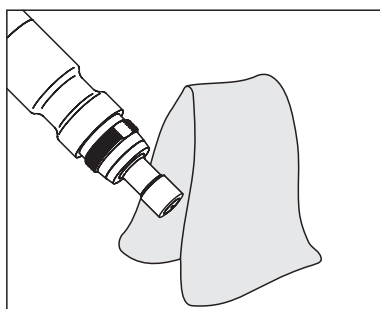

Wipe the counter electrode with a lint-free paper towel and carefully remove any loose white deposits.

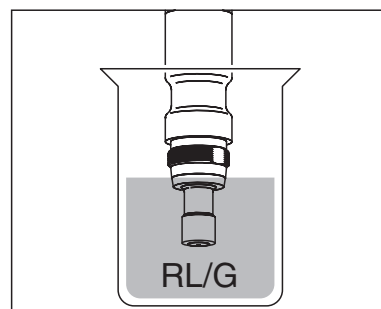

Immerse the sensor head including the counter electrode in RL/G cleaning solution.

Allow to react for 1 to 3 minutes.

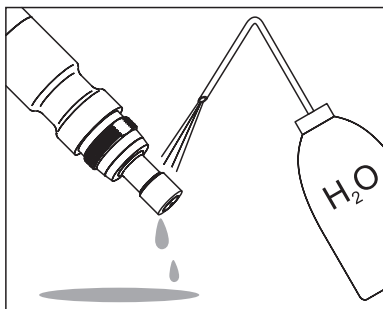

Thoroughly rinse the sensor head with deionized water.

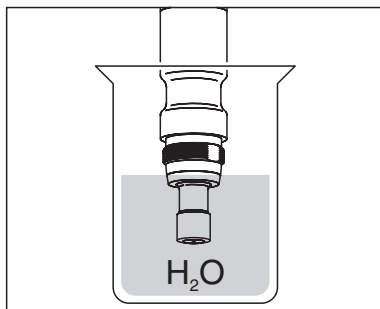

Water the counter electrode in deionized water for at least 10 minutes.

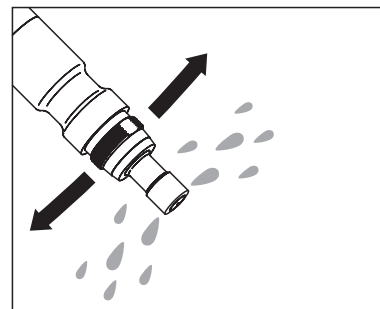

Carefully shake off the drops of water.

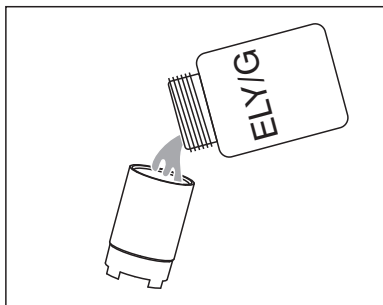

Fill a new membrane cap with ELY/G electrolyte solution.

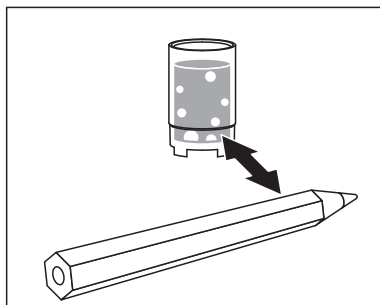

Remove any air bubbles by carefully tapping the membrane head. Additionally, you can prevent air bubbles by throwing the first filling away and refilling the membrane cap.



Rinse the sensor head with electrolyte solution.

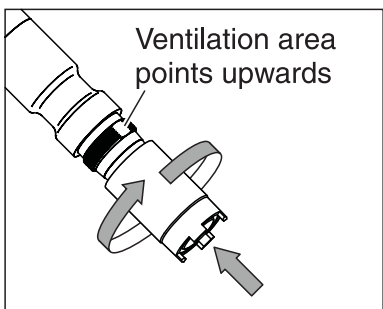

Hold the sensor inclined and screw on the membrane head fingertight using a paper towel. Excess electrolyte solution is forced out of the ventilation area.

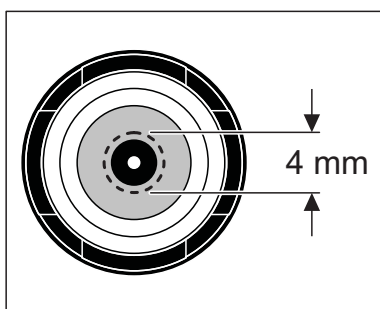

Check the filling: Inspect the face surface. No air bubbles may be present within the dashed circle. Air bubbles outside this area do not interfere.

**Note**

For measurements under high pressure the filling must be completely free of air bubbles.

Readiness to measure**Note**

If you want to measure very low oxygen concentrations (< 0.5 % saturation), we recommend to let the sensor rest overnight and then calibrate it.

5.5 Checking the sensor for freedom from zero-current

The sensor is zero-current free. Checking the module for freedom from zero-current is only necessary in the case of malfunctions that cannot be remedied by exchanging the electrolyte solution and membrane cap or by cleaning the electrodes.

There are 2 possibilities to check the sensor for freedom from zero-current:

- Measurement in a nitrogen atmosphere (recommended method)
- Measurement in a sodium sulfite solution according to DIN EN 25814/ISO 5814.

**CAUTION**

If you check the sensor according to DIN EN 25814/ISO 5814, do not leave the sensor in the sodium sulfite solution for more than 2 minutes. Danger of sensor poisoning!

Test criterion

The sensor is OK if the measuring instrument displays < 1 % D.O. saturation after 2 minutes.

5.6 Disposal

**CAUTION**

The ELY/G electrolyte solution irritates the eyes and skin. When dealing with the ELY/G electrolyte solution, observe the following points:

- **During working activities, always wear suitable protective gloves and protective goggles/face shield.**
- **If it comes into contact with the skin, rinse thoroughly with water and immediately change contaminated clothing.**
- **If it comes into contact with the eyes, rinse thoroughly with water and consult a doctor.**
- **Follow the safety datasheet.**

Sensor and membrane cap

For disposal, unscrew the membrane head and rinse the sensor and membrane head with water. We recommend disposing of the sensor without the membrane head as electronic refuse. The membrane head may be disposed of with the household refuse.

Electrolyte solution

Disposal according to the safety data sheet.

6 What to do if ...

Error symptom	Cause	Remedy
The sensor is in the air and the display shows 0.0 mg/l or 0 % O ₂	<ul style="list-style-type: none"> – No connection between measuring instrument and sensor – No electrolyte in the membrane head – Cable defective 	<ul style="list-style-type: none"> – Check connection between measuring instrument and sensor – Replace and refill the membrane cap (see section 5.3) – Return the sensor
The sensor cannot be calibrated	<ul style="list-style-type: none"> – Contaminated membrane head – Electrolyte depleted 	<ul style="list-style-type: none"> – Replace and refill the membrane cap (see section 5.3) – Subsequently, wait for 30 to 50 min and recalibrate.
The sensor still cannot be calibrated after changing the electrolyte and membrane head	<ul style="list-style-type: none"> – Contaminated electrodes or sensor toxification 	<ul style="list-style-type: none"> – Clean the electrodes (see section 5.4)
Leak display appears	<ul style="list-style-type: none"> – Membrane cap not screwed on tight enough – Hole in the membrane 	<ul style="list-style-type: none"> – Screw membrane head tighter – Replace and refill the membrane cap (see section 5.3)
Incorrect temperature display	<ul style="list-style-type: none"> – Temperature sensor defective 	<ul style="list-style-type: none"> – Return the sensor
Mechanical damage to the sensor		<ul style="list-style-type: none"> – Return the sensor
Meter displays <i>OFL</i> (display range exceeded)	<ul style="list-style-type: none"> – Short-circuit between working electrode and counter electrode 	<ul style="list-style-type: none"> – Clean the electrodes (see section 5.4). If the meter still displays <i>OFL</i>, return the sensor.

7 Technical data

General features	Measuring principle	Membrane covered galvanic sensor
	Temperature compensation	IMT compensation (calculated by the meter)
	Temperature sensor	Integrated NTC 30 (30 kΩ at 25 °C / 77 °F)

Dimensions (in mm)

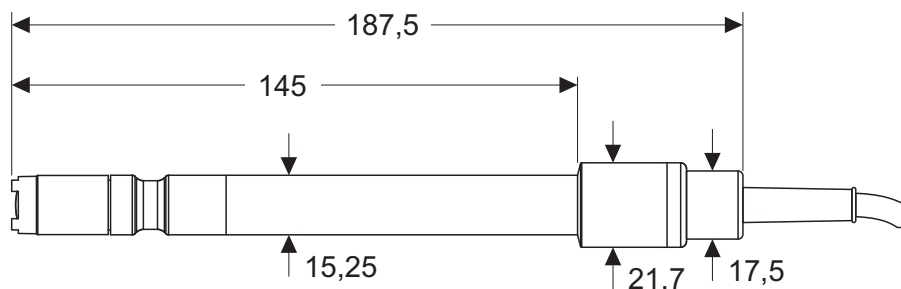

Weight 170 g (with 1.5 m cable)

Materials	Working electrode	Gold
	Counter electrode	Lead
	– Shaft	POM
	– Connection head	
	– Cable screw joint	
	– Membrane head	
	Membrane	FEP, 13 μm
	Sensor head	Epoxy, PEEK
Thermistor housing	VA steel 1.4571	
Seals	FPM (Viton)	

Connection cable	Lengths	1.5 ... 20 m
	Diameter	6 mm
	Smallest allowed bend radius	Fixed installation: 50 mm Flexible use: 80 mm
	Plug type	Socket, 8 pins

Pressure resistance	Sensor	IP 68 (6 bar)
	Sensor cable	IP 68 (2 bar)
	Plug	IP 67 (when plugged in)

The CellOx® 325 meets the requirements according to article 3(3) of the 97/23/EC directive ("Pressure equipment directive").

Measurement conditions	Measuring ranges at 20 °C (68 °F)	0 ... 50 mg/l D.O. 0 ... 600 % D.O. saturation 0 ... 1250 mbar D.O. partial pressure
	Temperature range	0 ... 50 °C (32 ... 122 °F)
	Max. allowed overpressure	6·10 ⁵ Pa (6 bar)
	Depth of immersion	min. 6 cm max. 20 m (depending on the cable length)
	Operating position	Any
	Approach flow	> 3 cm/s at 10 % measurement accuracy 10 cm/s at 5 % measurement accuracy 18 cm/s at 1 % measurement accuracy
	Storage conditions	Recommended storing method
Storage temperature		0 ... 50 °C (32 ... 122 °F)
Characteristics when delivered	Zero signal	< 0.1 % of the saturation value
	Response time at 20 °C (68 °F)	t ₉₀ (90% of the final value display after) < 10 s t ₉₅ (95 % of the final value display after) < 16 s t ₉₉ (99 % of the final value display after) < 60 s
	Own consumption of oxygen at 20 °C (68 °F)	0.008 µg·h ⁻¹ (mg/l) ⁻¹
	Drift	Approx. 3 % per month in the operating condition
	Response time of temperature measurement	t ₉₉ (99 % of the final value display after) < 60 s
	Precision of temperature measurement	± 0.2 K
	Working life	min. 6 months with one electrolyte filling

Pin assignment

Plug from the front:

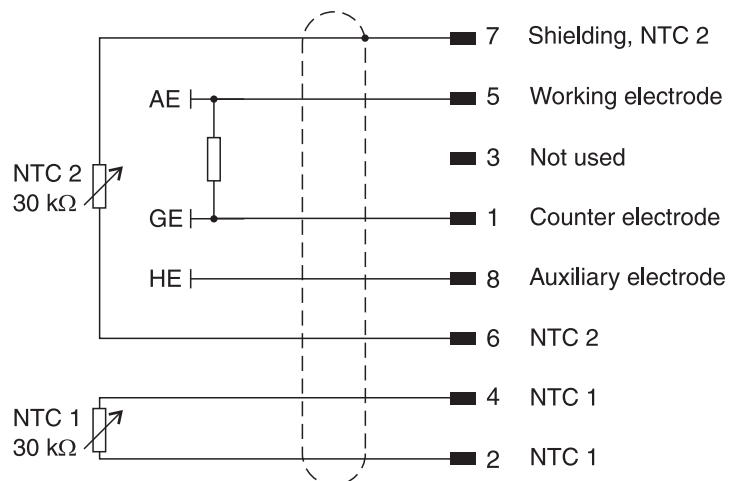
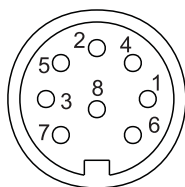

8 Wear parts and accessories

Wear parts and maintenance equipment

Description	Model	Order no.
Set of exchange membrane caps (3 pieces)	WP 90/3	202 725
Electrolyte solution	ELY/G	205 217
Cleaning solution for lead counter electrode	RL/G	205 204
Polishing strip	SF 300	203 680
Accessory kit, comprising: – 3 exchange membrane caps WP 90 – Electrolyte solution ELY/G – Cleaning solution, RL/G – Polishing strip, SF 300	ZBK 325	202 706

Accessories

Description	Model	Order no.
Calibration and storage vessel	OxiCal®-SL	205 362
Magnetic stirrer	Oxi-Stirrer 300	203 810
Stirring accessory - provides a constant, defined flow to the sensor, in conjunction with the Oxi-Stirrer 300	RZ 300	203 824
Funnel set - for BOD measurements in Winkler bottles	TS 19	205 710
Karlsruhe bottle - suitable for BOD measurement	KF 12	205 700
Fixing ring, recommended for measurements in Karlsruhe bottles	FR 19	205 712
Flow-through accessory - for pressure-free oxygen measurement with flow-through quantities from 25 to 65 ml/min.	D 201	203 730
Plastic armoring	A 325/K	903 830
Battery stirrer for depth measurements - only in conjunction with the A 325/K plastic armoring	BR 325	203 826



Note

For further accessories, refer to the WTW catalog or the Internet.