

49er MAST USERS MANUAL



•Photo courtesy of Jerelyn Biehl

COMPOSITE SPARS | COMPOSITE RIGGING | COMPONENTS | GLOBAL SERVICE

TABLE OF CONTENTS:

- Introduction**
- Care**
 - Washdown
 - Paint Scratches
 - Travel
 - Rig Inspections
- Quick Set-Up Guide**
- Set-Up Tips**
 - Halyard Threading
 - Joining the Mast
 - Attaching Trapeze Lines
 - Attaching Stays
- Tuning Guide**
 - Mastbend
 - Rig Tension
- Updates**
 - Retrofit Details
 - Extra Fastener added to Top Spreader*
 - Gennaker Halyard Deflector*
 - Vang Strop*
- Mast BOM (Bill of Materials) – Parts List**
- Mast Sub Assemblies BOM- Parts List**
- Rig Spare Parts**
- Dealers**
- Warranty**
- About Southern Spars**

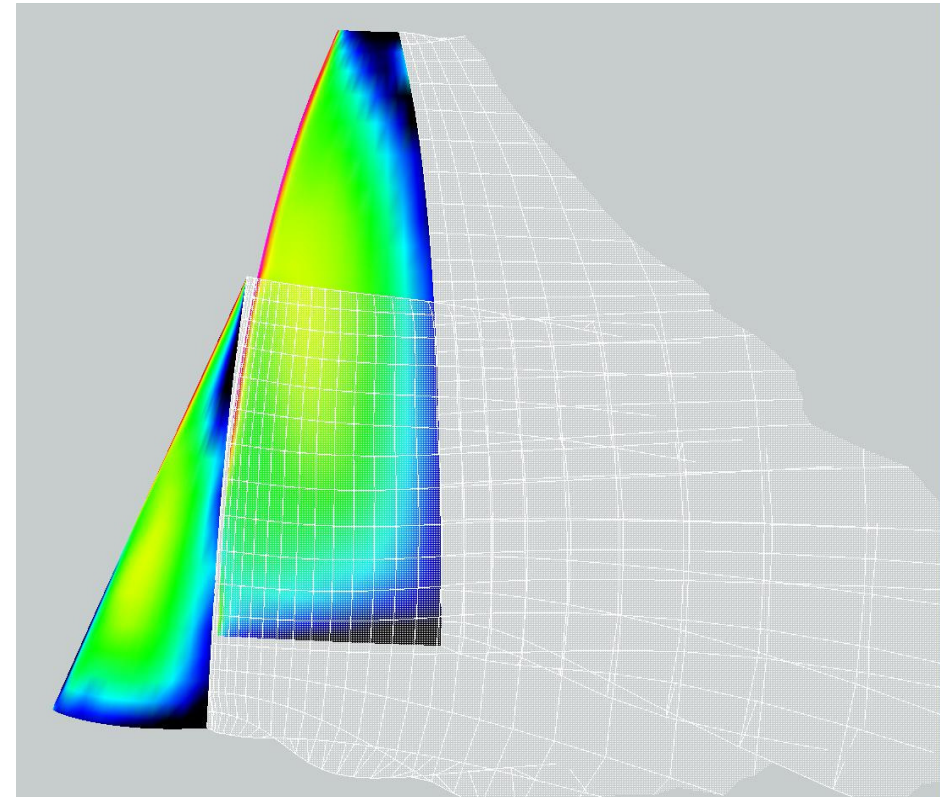

Flow simulation of 49er during rig development

INTRODUCTION:

Southern Spars is the licensed supplier of the 49er rig. The three piece male moulded mast is made from 100% standard modulus carbon and is available through licensed 49er dealers.

In carbonising the 49er rig, the goal was to develop a rig that could be easily and accurately reproduced with an emphasis on the details that affect performance.

The focus was on how to achieve consistency of: bend, weight and CG. 'Bend' is determined by the tube stiffness, spreader angle and spreader stiffness, while weight and CG are controlled through strict quality control of materials.

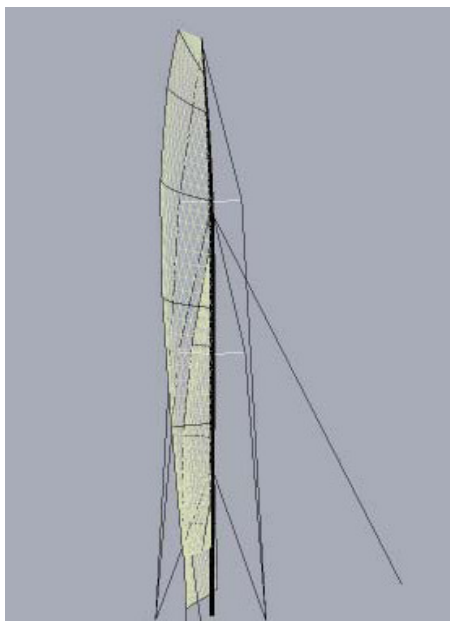

It was also important to ensure the rig retained its ability to perform through the full wind range while targeting an ideal crew weight of 155-160kg.

Before building the first prototype rig, many hours were spent running finite element studies of the mast-sail combination to ensure the rig performed properly throughout the full wind range.

Theoretical rig setup (dock tune) was established and the boat was run through a range of conditions using the software to simulate real sailing loads to output the deformed sailing shapes of the mast and sail. The mast stiffness and sail design was changed many times and fine tuned using the software before it was made and sent sailing. Independent on-the-water testing was conducted by Julian Bethwaite and his team, using the first prototype rig in conditions ranging from 5-30 knots along with a range of crew weights.

The rig has been developed as a 3 piece mast. The longest section is less than 4m so it is able to be easily freighted around the world. Both sets of spreaders are identical and interchangeable. The spreaders slide over the tube joining spigots between the mast tubes and are separate parts. This allows simple assembly and ensures that the spreaders can be easily transported separately and protected from damage.

- Southern Spars have developed a unique system where the spreaders automatically line up when the mast sections are fitted together.
- The main and spinnaker halyard sheaves are incorporated into the masthead fitting.
- Purchase systems for the Main and Jib halyards are now attached to the mast base to give more travel and easier access for adjustment.
- The main halyard has a 2:1 purchase at the head, plus a 2:1 adjustment at the base.

CARE:

WASHDOWN

Ensure the spar is washed down regularly and all salt has been removed. This will help prevent corrosion of parts.

The mast should be thoroughly washed down once a month, inside and out, to keep it in top condition.

PAINT SCRATCHES

Paint scratches should be touched up to avoid bare tube being exposed to the elements.

Any 2 part polyurethane paint system can be used to touch up the spars.

TRAVEL

When shipping your mast, or travelling by road, it is important to package it well using covers which are available from Southern Spars through your dealers.

Ensure that rigging is removed to prevent the stays from wearing or banging against the mast. It is recommended a full inspection is performed when re-rigging the mast.

RIG INSPECTIONS

New Stays will stretch slightly after sailing; therefore it is important to re-inspect your tuning each day for the first 2-3 sessions after sailing with the new rigging.

Tape any clevis pins or sharp edges to prevent tearing of the spinnaker.

WEEKLY INSPECTIONS

All halyards, taping etc should be checked on a weekly basis

MONTHLY INSPECTIONS

Check to see that all sheaves are free turning and well lubricated

Check for wear on stays and spreaders

BI-ANNUAL INSPECTION & RE-RIGGING INSPECTION

Check all fittings for wear

Check mast tubes and all composite parts for any damage caused during sailing

QUICK SET-UP GUIDE:

1. Fit spreaders to midsection.
Slide top spreader (with dynex loops) over join at top of midsection. Slide bottom spreader over bottom join.



2. Fit main halyard and gennaker halyard going either side of upper bolt



3. Fit jib halyard



4. Join mast sections together

5. Thread halyards through mast base



6. Attach mastbase

7. Align spreaders with mast base and ensure sail track is aligned. Tightly fasten screws.



8. Fit upper stays to bolt and run through top spreader .

9. Fit shrouds (just below top spreader), and run through bottom spreader



10. Fit forestay and lowers

11. Tie trapeze lines through both ends of Dynex loop

SET-UP TIPS:

USEFUL TOOLS WHEN ASSEMBLING THE MAST

- ❑ Spanner for M5 nuts
- ❑ Electrical tape
- ❑ 3mm Allen Key
- ❑ 5m of 4mm wire as a threading guide wire

HALYARD THREADING

The main halyard is 3mm dynex rope with a 4mm Spectra tail. Remove the sheaves in the head fitting and tie the end of the halyard to the lower clevis pin on the back of the head fitting.

Remove the Uppers stay bolt. The main halyard is a 2 to 1 system and goes through the shackle that attaches to the head of the mainsail.



Once you thread the main halyard (behind upper bolt) and gennaker halyard (in front of upper bolt) through the tip section pull tight and tape into place. At this point look up inside the tip section to check the halyards aren't twisted.

- Thread the jib halyard through the Harken HK 302 exit block at the top of the midsection. Then thread the jib halyard through the midsection and tape into place.

Now run the main and gennaker halyards through the midsection, again pulling each halyard tight once they have gone through. Check that the halyards are not twisted. Thread the halyards through the bottom section and out the mastbase. It is easiest to do this with the mastbase not attached to the mast. The gennaker halyard exits out of the front of the mastbase. The main and jib halyards exit through the back sheaves in the mastbase. Before re-attaching the mastbase do a final check that the halyards are not twisted and are running freely.

JOINING THE MAST

To join the mast together, slide the top spreader (spreader with Dynex loop on) over the join at the top of the midsection. Fit locating screw. Slide bottom spreader over join at the bottom of the midsection. Fit locating screws. Now align the spreaders with the mastbase, making sure that the sail track is aligned. Once aligned, tightly fasten locating screws.



When attaching the spreaders and joining the mast sections make sure that the joins butt up against each other. The angled cuts are done at exactly 22.5%. If you are to fit a replacement to your rig and it doesn't accurately align, lightly sand the join of the mast and use a small rats tail file in the fastening hole so the screw doesn't pull the mast out of alignment.

ATTACHING TRAPEZE LINES

When attaching the trapeze lines to the Dynex loops at the top spreader, make sure both trapeze lines go through both loops. Do not attach one trapeze line to one loop, then the other trapeze line to the other loop - both trapeze lines need to be through both loops.

ATTACHING STAYS

Please note: The T bars on the forestay and main shrouds need to be “long neck” T Bar hooks. These will then sit correctly and allow the swages to line up correctly with the wire.

Fit one end of one of the uppers (stays with eyes on both ends) onto the uppers bolt making sure there is a washer on each side between the mast and upper stays. Then bolt through mast, ensuring the gennaker halyard is in front of the pin and the main halyard is behind the pin. Fit the second upper stay and tighten uppers bolt. Remove the clevis pins and retainer stay plates from the outer ends of the top spreaders. Place stay into hook, then refit stay retainer back into spreader with the hook facing forwards.



Next fit the shrouds by inserting the T-bar end of the stay in the mast. This should be inserted just beneath the top spreader.

Remove the clevis pins and retainer stay plates from the outer ends of the bottom spreaders. Place stay into hook, then refit stay retainer back into spreader with the hook facing forwards. Wrap tape around the spreader end. Rubber splicing tape is best.

Fit the forestay to the mast by inserting the forestay on the front of the mast just above the top spreader. Fit the lowers in the bottom section. Before putting the rig up, perform a final check, confirm that all fittings are attached correctly, nuts are tightened, and that all clevis pins and sharp pieces are taped.



NOTE: Under Class rules, the mast sections and spreaders must be able to come apart for measurement purposes.

If you choose to glue your spreaders to the mast section, then ensure you use a good release agent and apply it well so the spreaders and mast are not damaged when you are required to break them apart for measurement.

TUNING GUIDE:

Over time the top sailors in the class will develop and fine tune the fastest settings for the new carbon rig.

We will continually update the tuning guide with as much of that information as possible, this will be available on our website.

MASTBEND

The old rig went best with a straight bottom section. The top section was relatively soft and this produced a dynamic response that automatically depowered the rig in gusts.

The new rig relies more on the square top for depowering. There is less luffcurve in the top of the main so the head will open automatically in gusts to an even greater degree than the old rig.

To support the square head, we made the top of the rig a lot stiffer. The lower section of the mast is very similar stiffness to the old rig, however the whole rig needs to be set up with a more even bend to get a good balance on the helm.

If you set up the mast straight in the lower sections like before, then the boat will feel stalled at times. Forget about the way the mast looked before and set up the bend so that the main looks good.

There will be less change in sail depth through the wind range and the main will retain a tighter leech for longer, so you will probably set up the main slightly flatter than before.

You will need to use a lot higher vang and cunningham tensions than with the old rig.

Happy sailing, and please email any tips or tuning information that we can use to develop a more detailed guide to onedesign@southernspars.com

RIG TENSION

The mast is stiffer overall, so the shroud tensions have changed. The top of the mast is a lot stiffer, so the uppers require more tension to set the head at the right depth.

The head needs to be flatter than before for the head to work, so it may take some time to get used to looking at the flatter top.

Don't worry about the tension of the main shrouds. As long as the forestay is at the right tension and the uppers and lowers have the main set up at the right depth and behaving right through the wind range then the shrouds are at the right tension.

This style of rig is probably a little more sensitive to lowers tension than the old rig, and fine tuning them will make big differences to the balance through the wind range.

	LIGHT	MEDIUM	HEAVY
FORESTAY	25	28	30
LOWERS- D1	20	20	20
SHROUDS- V1/D2	28	32	36
UPPERS- V2/D3	20	20	18

UPDATES:

NB: Over time there will be updates in some of the fittings used and other detail changes to the rig. These will originate from sailors feedback and new ideas. Any changes are agreed to by Julian Bethwaite and these changes will not affect the performance of the rigs. The tube bend and weight will remain within the agreed tolerances and will comply with the class rules.

DATE	UPDATE DETAILS	EXPLANATION
Nov 08	Top joining not glued into middle section	The first batch of masts had the sleeve glued into the top section. This put all of the shroud loads onto the sleeve and glue joint. The new solution transfers the loads to the mast tube.
Dec 08	Join area strengthened	Some early rigs experienced damage on the ends of the tubes after hard sailing. An additional internal sleeve was added at each join to increase the bearing surface area at the end of each tube.
	Spinnaker halyard sheaves changed	Harken sheaves were swapped for Allen SS ball bearing sheaves
	Gooseneck & Vang pin detail changed	Larger washers were added above and below the gooseneck and vang toggles. Please check your washers. Vang bracket clevis pin was replaced with a bolt
	Jib Sheavebox changed	Jib halyard sheave box changed from internal fitting to simple Harken drop in box
June 09	Stopper added to top of Sail track	A slug was added to top of track to match cut back in boltrope . This will stop excessive damage to carbon masthead by the halyard shackle
Aug 09	Gooseneck & Vang Toggles Strengthened	Gooseneck and vang toggles changed to a new stronger Riley toggle.
	Spinnaker Halyard deflector changed	The old deflectors were bending upwards from halyard loads when hoisting. The new deflector was designed to be retrofitted into the same holes and to stay in place under these loads.
	Vang Strop added as standard part	Vang take-off strop has been added as standard part to mast. **Retrofit details below.
	Extra fastener added to spreader	Fastener added to top spreader under the track at back. **Retrofit details below.
	Halyard Hanger Strengthened	Extra weld added to halyard cleat hangers to stop breakages.
Nov 09	Patching added at Lowers	An extra layer of carbon patching was added at the D1 to strengthen the mast in this area.
	T-bar neck length refined	During 2009 a number of T-bars cracked. To fix this the neck length of the T-bar was shortened a little. The neck must be only just long enough to allow the swage to line up with the end of the spreader. Also, please ensure that your rigger uses a roll swage machine and not a pull swage machine. Check T-bar hook regularly.
July 10	Testing of Spreader Keyway system	Keyway system to stop spreader rotation will be tested for 3-6 months before introduction on all new rigs for 2011.

RETROFIT DETAILS:

EXTRA FASTENER ADDED TO TOP SPREADER:

The new rigs are experiencing higher loads than the old rigs. This is partly due to the new sail plan, and also the strength and stiffness of the new carbon mast.

Sailors are commenting on how much harder they can push the boats and how they are applying higher loads.

We are getting some good feedback from the rigs and would like to alert sailors to the following issues:

1) Top spreader twisting.

A number of crews have commented that the top spreaders twist from tack to tack. In most cases this is due to the fastenings coming loose. If the fastenings ever come loose, there is the risk that the holes will slightly elongate and then it will be hard to ever stop movement. We suggest that all fasteners are done up firmly with Loctite thread locker to stop them coming loose during sailing. To hold the spreader in place more firmly you can also add another fastener at the back of the spreader. This can be fitted either under the track or inside the track. Use an M5 CSK machine screw. Drill a 4mm hole through the spreader band and then tap into the joining sleeve. Again use Loctite to hold the screw firmly in place. Please see photos below for more information on how to do this.

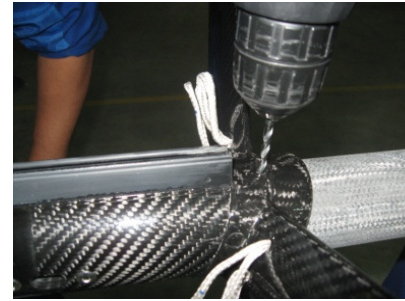

Drill 4mm hole, at centreline of Spreader and centre of track

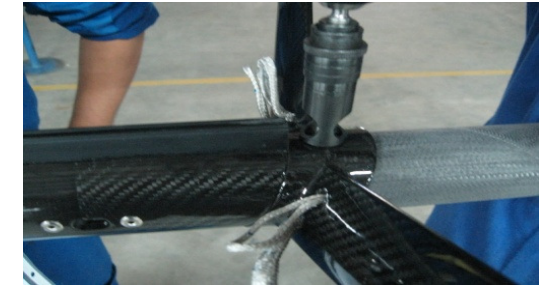

Countersink hole, do not drill too deep.



Tap 4mm hole with M5 tap



Fasten CSK M5x12mm fastener

GENNAKER HALYARD DEFLECTOR COMING LOOSE:

Some deflectors are coming loose from the loads put on them when the gennaker is initially hoisted. All new masts are being fitted with a new fitting which solves this problem. If your fitting has come loose, then please contact your 49er dealer and you can fit the new fitting. They use the 2 holes from the old fitting, plus require 1 extra rivet to be added.

Please see photo below of a new fitting being attached.

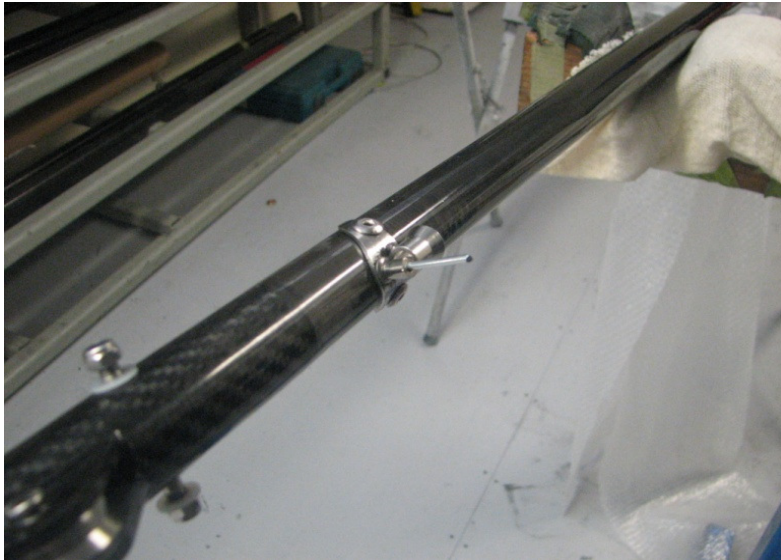

VANG STROP:

A saddle is fitted to fix the height of the block.



2009 World Championships Lago di Garda:



All Photos courtesy of Jerelyn Biehl



COMPOSITE SPARS | COMPOSITE RIGGING | COMPONENTS | GLOBAL SERVICE

MAST BOM:

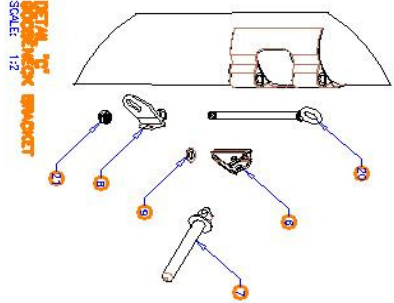
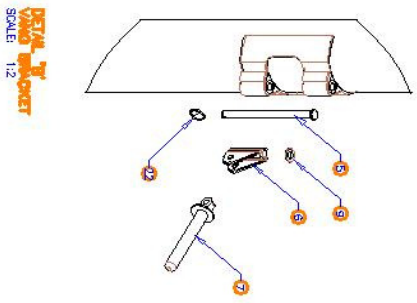
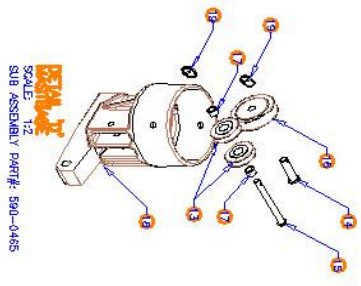
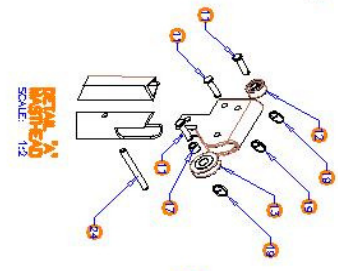
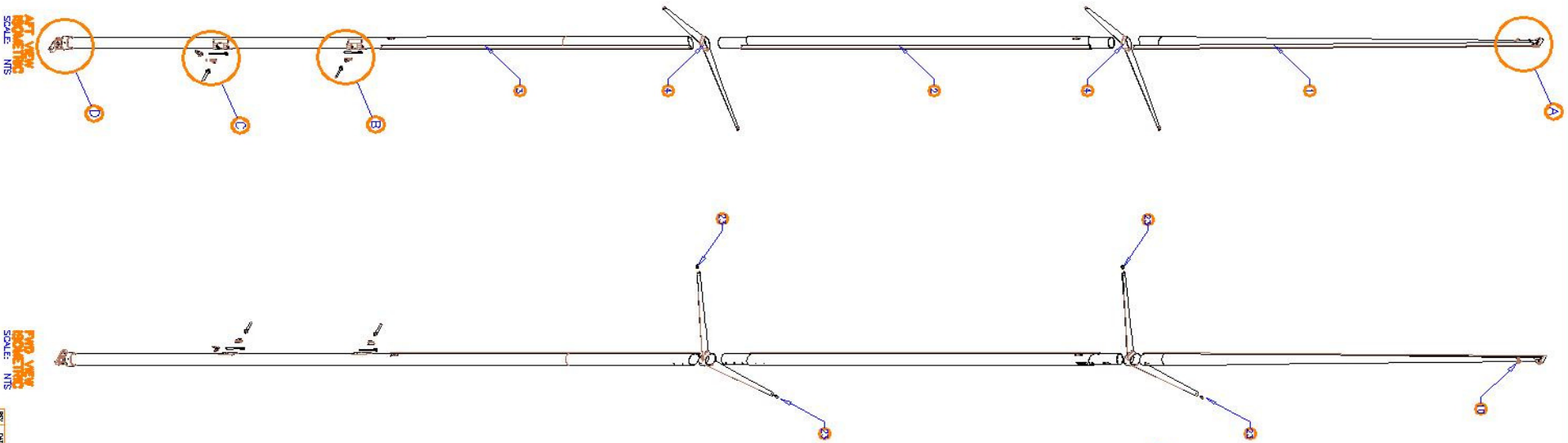

ITEM	DESCRIPTION	PART No.	REV.	QTY.
1	49er Mast Section (COMPLETE)	890-0485	A	1 EA
2	49er Section (COMPLETE)	890-0482	A	1 EA
3	49er Section (COMPLETE)	890-0483	A	1 EA
4	49er Mast Section (COMPLETE)	890-0484	A	1 EA
5	49er Mast Section (COMPLETE)	890-0485	A	1 EA
6	49er Mast Section (COMPLETE)	890-0486	A	1 EA
7	49er Mast Section (COMPLETE)	890-0487	A	1 EA
8	49er Mast Section (COMPLETE)	890-0488	A	1 EA
9	49er Mast Section (COMPLETE)	890-0489	A	1 EA
10	49er Mast Section (COMPLETE)	890-0490	A	1 EA
11	49er Mast Section (COMPLETE)	890-0491	A	1 EA
12	49er Mast Section (COMPLETE)	890-0492	A	1 EA
13	49er Mast Section (COMPLETE)	890-0493	A	1 EA
14	49er Mast Section (COMPLETE)	890-0494	A	1 EA
15	49er Mast Section (COMPLETE)	890-0495	A	1 EA
16	49er Mast Section (COMPLETE)	890-0496	A	1 EA
17	49er Mast Section (COMPLETE)	890-0497	A	1 EA
18	49er Mast Section (COMPLETE)	890-0498	A	1 EA
19	49er Mast Section (COMPLETE)	890-0499	A	1 EA
20	49er Mast Section (COMPLETE)	890-0500	A	1 EA
21	49er Mast Section (COMPLETE)	890-0501	A	1 EA
22	49er Mast Section (COMPLETE)	890-0502	A	1 EA
23	49er Mast Section (COMPLETE)	890-0503	A	1 EA
24	49er Mast Section (COMPLETE)	890-0504	A	1 EA

Southern Spars

49er MAST
MAST LAYOUT
CUSTOMER SPARES

590-0480

1:10

1/1

MAST SUB ASSEMBLIES BOM:

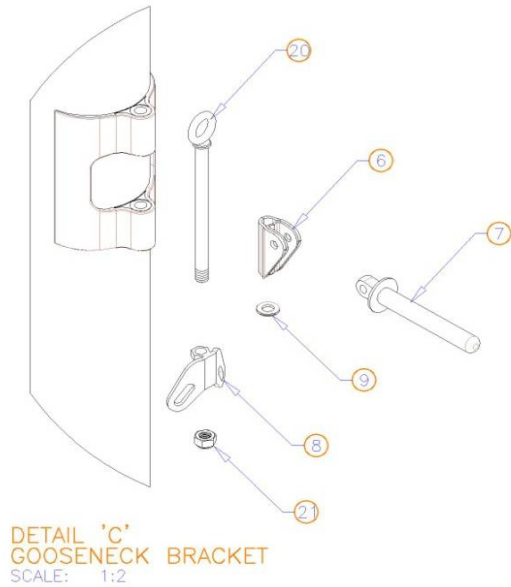
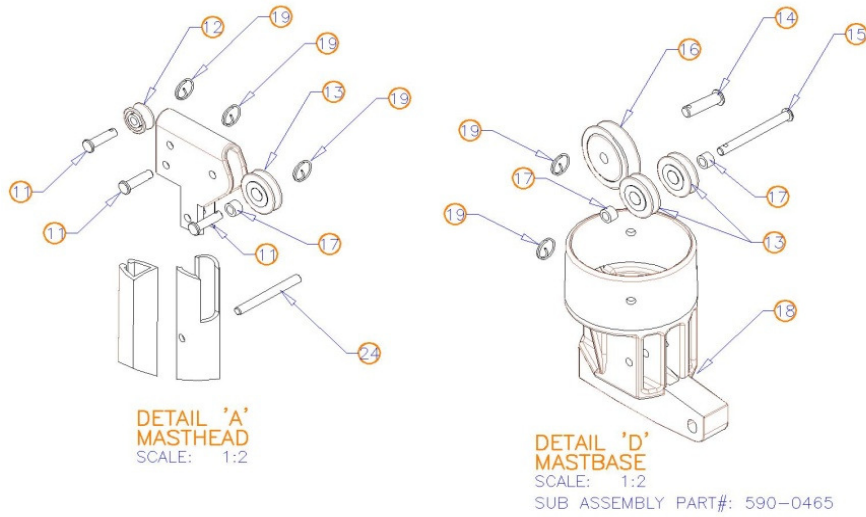

DESIGN BOM					
ITEM	DESCRIPTION	PART No.	REV	QTY	
1	49er TOP SECTION (COMPLETE)	590-0461	A	1	EA
2	49er MIDDLE SECTION (COMPLETE)	590-0462	A	1	EA
3	49er BOTTOM SECTION (COMPLETE)	590-0463	A	1	EA
4	49er ONE-PIECE SPREADER	590-0482	A	2	EA
5	CLEVIS PIN 1/4 x 3.1/2 92390A182	150-1107		1	EA
6	RILEY RM682 GOOSENECK TOGGLE	150-1085		2	EA
7	RILEY RM679 GOOSENECK PIN	040-0372		2	1
8	HALYARD CLEAT HANGER	590-0476	A	1	EA
9	WASHER 6MM FLAT MMC 90965A170	080-0295		2	EA
10	SADDLE WITH EYE RONSTAN RF1058	150-1104	A	1	EA
11	CLEVIS PIN 3/16 x 3/4 MMC 92390A102	150-0017		3	EA
12	SHEAVE 16mm HARKEN 415	040-0859		1	EA
13	SHEAVE 25mm x 8mm A4986-8	040-0857		3	EA
14	CLEVIS PIN 1/4 x 7/8 MMC 92390A186	150-1105		1	EA
15	CLEVIS PIN 3/16 x 2 MMC 92390A112	150-1106		1	EA
16	SHEAVE 38mm HARKEN 307	040-0293		1	EA
17	BUSH	303-1346	A	3	EA
18	MAST BASE ALLOY CASTING	590-0416	A	1	EA
19	SPLIT RINGS RONSTAN RF113	150-0059		6	EA
20	CLEVIS PIN 1/4 - 20 x 4 1/2	590-0473		1	EA
21	1/4-20 NYLOC NUT	080-0307		1	EA
22	SPLIT RINGS RONSTAN RF114	150-1259		1	EA
23	STAY RETAINER	322-0205	A	4	EA
24	THREADED PIN 46mm	319-0023	A	1	EA

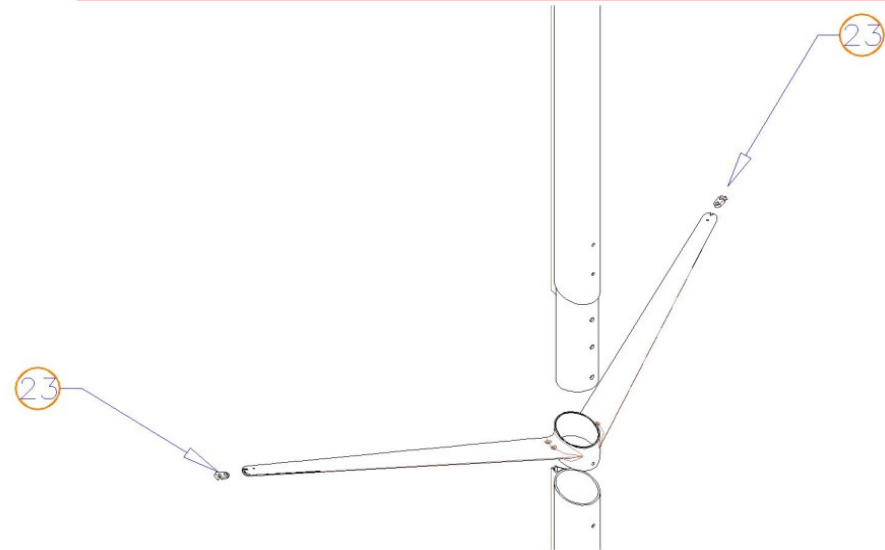

RIG SPARE PARTS:

Available through 49er Dealers only

Part Number	Part	Description
590-0461	TOP SECTION	Complete with masthead and all fittings
590-0462	MIDDLE SECTION	Complete with all fittings
590-0463	BOTTOM SECTION	Complete with mastbase and al fittings
550-0200	WIRE RIGGING SET	Dyform Forestay; Lower; Shrouds & Uppers; excludes stay adjusters
590-0480	HALYARD SET	Main & jib halyards including adjustment system; Tapered Spinnaker Halyard
590-0482	SPREADERS (EA)	Excluding stay retainers and pins
322-0205	STAY RETAINER PLATES	Spreader end retainer plate
590-0465	MASTBASE	Anodised casting without sheaves and pins
590-0464	GOOSENECK/VANG BRACKET	Carbon Gooseneck/vang bracket excluding pin
590-0476	HALYARD CLEAT HANGER	Stainless Steel fitting fitted to gooseneck for halyard cleats
590-0485	MAST COVER- RIGGED	Zippered cover to fit onto rigged mast; with openings for each spreader
590-0486	MAST COVER- TRAVELLING	Carry bag for mast in 3 pieces
590-0483	SPREADERS BAG	Padded cover for 2 sets of spreaders
590-0484	RIGGING BAG	Bag for stays and halyards



COMPOSITE SPARS | COMPOSITE RIGGING | COMPONENTS | GLOBAL SERVICE

DEALERS:

49er masts, rigging, spare parts and covers are available from the following suppliers:

Argentina

Martin Bulloch Marine
San Fernando
P: +54 11 4745 8428
Martin Bulloch
info@bulloch.com
www.bulloch.com

Australia

Bethwaite Design
Woollahra Sailing Club
Vickery Ave, Rose Bay
NSW 2029
Australia
P: +61 2 9371 6338
Clynton Wade-Lehman
clynton@bethwaite.com
www.bethwaite.com

Italy

Nautivela srl
via Gardone 8,
Milano
Italy
P: +39 02 55212116
F: +39 02 55212116
Paolo Portiglia
paolo@nautivela.com
www.nautivela.com

Japan

Performance Sailcraft Japan
3 13 31, Ayase shi
Kamitsuchitana Minami
Kanagawa Ken, 252
Japan
P: +81 467 76 1051
F: +81 467 76 1052
Takao Otani
psj@psjpn.co.jp
www.psjpn.co.jp

New Zealand

Mackay Boats Ltd
24 Manga Rd
Silverdale, Auckland
New Zealand
P: +64 9 426 4306
Dave Mackay
dave@mackayboats.com
www.mackayboats.com

North America

Pitch Pole Skiff Products Inc
18 Place Decary
Dorval, QC
H9S 3J8
P: +1 514 944 1705
Tej Trevor Parekh
trevor@49er.com

United Kingdom

Ovington Boats Ltd
Tanners Bank
North Shields
Tyne & Wear, NE30 1JH
Great Britain
P: +44 (0) 77 19 59 49 49
Chris Turner
chris@ovington.co.uk
www.ovingtonboats.co.uk

WARRANTY:

WARRANTY

Southern Spars will remedy faulty workmanship provided that any claim by the Customer for remedy of workmanship was notified to Southern Spars in writing within 12 months of the delivery date of the mast.

Southern Spars will, if requested to do so, use reasonable endeavours to assign to the Customer the benefit of guarantees and warranties given to Southern Spars by third party suppliers or manufacturers.

The warranties above do not extend to and Southern Spars shall not in any event be liable for any failure or damage arising from fair wear and tear.

Any claim shall be made directly to the Dealer from whom the rig was purchased.

Warranty claims must be made on the correct form before any work is undertaken on the part concerned.

ABOUT SOUTHERN SPARS:

Southern Spars has established its place as a world leader in the design, construction, installation and servicing of carbon fibre masts, booms, composite components and rigging. Its rigs power a wide range of yachts, from one-design class yachts to grand prix racing yachts, cruising yachts and superyachts.

Innovation, quality and an insatiable desire to produce what the customer requires runs through the company's culture. These qualities have contributed to producing product for numerous race victories, including the Volvo Ocean Race, Vendee Globe, America's Cup, Sydney-Hobart, plus supplying rigs to some of the hottest one-design classes like the Olympic 49er, Elliott 6, Melges 20, 24 & 32 & the Farr 30 & 40. The same design expertise, manufacturing methods, materials and components utilised on these racing rigs are applied to every rig built by Southern.

Southern Spars also operates a rig service network and is manufacturing composite rigging. The specialist rig service business Rig Pro, has service centres worldwide. The Composite Rigging division, manufactures custom lightweight rigging products, including EC6+ carbon rigging, Aramid rigging and the Luff Rope.

Southern Spars has centres in the USA, Europe, South Africa, Sri Lanka and headquarters in Auckland, New Zealand. It is supported by the North Marine Group and shares the resources of that group of companies.

For more information: www.southernspars.com