

LAGAN^{AU}

DW60



Design and Quality
IKEA of Sweden

Table of contents

Safety information	4	How to load the racks	10
Product description	7	Cleaning and maintenance	12
Control panel	7	What to do if ...	13
Washing programmes	8	Environmental concerns	17
Daily check	8	IKEA warranty	18
Daily use	9		

Safety Information

Before using the appliance for the first time carefully read this quick reference guide and the assembly instruction!

The control panel of this dishwasher activates pushing any button except cancel/off button.

For energy saving the control panel deactivates automatically after 30 seconds if no cycle has started.

Removing the packaging and inspecting the contents

After unpacking, make sure that the dishwasher is undamaged and that the door closes correctly. If in doubt, contact a qualified technician or your local retailer.

Before using the dishwasher for the first time

- The appliance is designed to operate at ambient temperatures of between 5°C and 45°C.
- This dishwasher has been tested by the manufacturer to ensure it functions correctly. Such testing may leave slight drips/ water marks which will disappear with the first wash.

Energy and water savings

- Do not rinse crockery under running water.
- Always fully load the dishwasher before running it or select the “Half load/ Multizone” option (if available).
- If ecological energy sources are available such as solar panel heating, heat pumps or centralised heating

systems, the appliance may be connected to the hot water mains up to a maximum temperature of 60°C.

Make sure the water inlet hose is of the correct type (“70°C Max” or “90°C Max”).

Child safety

- Keep the packaging materials out of the reach of children.
- Children must not be allowed to play with the dishwasher.
- Store the detergent, rinse aid and salt out of the reach of children

Safety warnings

- This appliance is not intended for use by persons (including) children with reduced physical, sensory or mental capabilities, or lack of experience and knowledge unless they have been given supervision or instruction concerning use of the appliance by a person responsible for their safety.
- Children should be supervised to ensure they do not play with the appliance.
- Do not operate the appliance in the open air.
- Do not store flammable materials in close proximity to the dishwasher.
- The water in the dishwasher is not potable.
- Do not use solvents inside the dishwasher: risk of explosion!
- The door should not be left in the open position since this could present a tripping hazard.

- The open dishwasher door can only support the weight of the loaded rack when pulled out. Do not rest objects on the open door or sit or stand on it.
- Sharp items that might cause injury (e.g. knives), must be placed in the cutlery basket with the sharp end facing downwards. Long-handled utensils must be arranged horizontally in the upper rack, with the sharp end facing away from the front of the appliance.
- Before cleaning or carrying out maintenance, disconnect the mains plug and turn off the water tap; also in the event of any malfunction.
- Repairs and technical modifications must be carried out exclusively by a qualified technician.

WARNING: Some Dishwasher detergents are strongly alkaline. They can be extremely dangerous if swallowed. Avoid contact with the skin and eyes and keep children away from the dishwasher when the door is open. Check the detergent receptacle is empty after completion of the wash cycle.

Water connection

- Connection to the mains water supply must be carried out by a qualified technician in compliance with the manufacturer's instructions and applicable local safety regulations.
- All local water board regulations must be complied with. Water supply pressure: 0.03 - 1.0 MPa.
- The inlet hose must be securely clamped to the water tap to prevent leaks.
- The inlet water temperature varies according to the model installed. Inlet hose marked: "25°C Max": up to a maximum of 25°C. Other models: up to a maximum of 60°C.
- Depending on the appliance model, the solenoid valve of the inlet hose will be activated by the mains voltage.
- Make sure the inlet and drain hoses are

kink-free and are not crushed.

- Fix the drain hose to the siphon with a clamp to prevent it from coming off during operation.
- When installing the appliance, make sure water can drain freely (remove the siphon plug if necessary).
- Do not use old or damaged hoses. Use only the hoses provided or new ones, which can be requested from the After-Sales Service.
- If hoses are not long enough, contact your local dealer.
- Do not cut hoses and, in the case of appliances fitted with a waterstop system, do not immerse the plastic casing containing the inlet hose in water.
- Before using the appliance for the first time, check the water inlet and drain hose for leaks.

Electrical Connection

- All local electricity board regulations must be complied with.
- Voltage information is shown on the rating plate mounted inside the door on the right hand side.
- The appliance must be earthed as prescribed by law.
- Do not use extension leads or multiple adapters.
- If the power cable is damaged, replace it with an identical one. The power cable must only be replaced by a qualified technician.
- After appliance installation, the mains plug must be easily accessible so that the appliance can be unplugged if necessary at any time.

General indications

- The appliance must only be used in the household and according its purpose.
- Do not use the dishwasher until it has been fully assembled.
- Do not use the dishwasher if it has been damaged in transit. Contact After-Sales

Service or your local dealer.

- Before carrying out any cleaning or maintenance operations, unplug the appliance and turn off the water tap. The same applies in the event of a malfunction.
- Do not use abrasive products or alcohol on the control panels.

Resistance to frost

If the appliance is placed in surroundings exposed to the risk of frost, it must be drained completely. Turn off the water tap, remove the inlet and outlet hoses, and let all the water drain away. Make sure there is at least 1 kg of dissolved regeneration salt in the salt reservoir, to protect the appliance from temperatures of up to -20°C . When the program resumes, an error message may be indicated (see page 13).

CANCEL/Off indicator blinks 6 times - the appliance must remain at an ambient temperature of min. 5°C for at least 24 hours.

After eliminating these faults, RESET the appliance (see chapter "What to do if...").

Product description

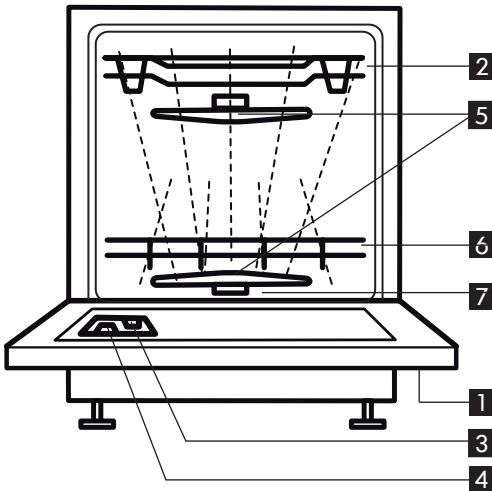

- 1** Control panel
- 2** Upper basket
- 3** Rinse aid dispenser
- 4** Detergent dispenser
- 5** Upper and lower spray arms
- 6** Lower rack
- 7** Filters

Control panel



Functions







washing cycle, the cycle is temporarily paused: the Start indicator blinks. To resume the cycle close the door and push Start button again.

A PROGRAM SELECTION BUTTON
 Push "Programs" button (repeatedly) until the indicator of the required program lights up (see "washing programmes").

B START/RESUME BUTTON
 Push this button to start the selected program: the indicator lights up and goes off at the end of the program. When the door is opened during a

C CANCEL/OFF BUTTON
 Push this button to switch off the control panel.
If pressed when a program is running it cancels the program ongoing draining water for 1 minute.
If pressed when the dishwasher is switched off it drains any possible liquids from dishwasher (1 minute process).
 If the indicator flashes repeatedly, see chapter "What to do if ...".

Washing programmes

Table of programs				Detergent	Drying phase
P	Programs	Loading instructions			
1	 Pre-Wash	cold	Crockery to be washed later.	-	No
2	 Quickwash	40°C	Lightly soiled crockery, with no dried-on food.	X	No
3	 Eco	40°C	Normally soiled crockery. Energy-saving program.	X	Full
4	 Intensive	70°C	Recommended program for heavily soiled crockery, especially suitable for pans and saucepans.	X	Full

Load capacity: 12 place settings.

Daily check

Adding rinse aid (not necessary when you use tablets).

How to adjust the rinse aid dosage regulator

 Check the rinse aid indicator to check the level into the dispenser

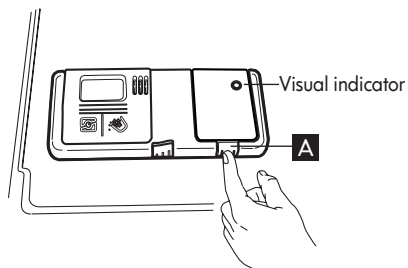
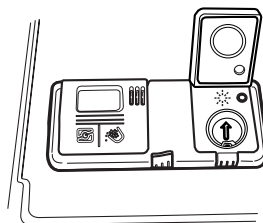

Add rinse aid to the max. line ~150 ml



If required, open the cover A (press the dedicated button).

The rinse aid dosage can be adjusted to the detergent used. The lower the setting, the less rinse aid is dispensed (factory setting: position 4).

Press the button to open the cover A.

Using a coin or similar object, turn the arrow to the desired setting.

After adjusting the rinse aid setting, shut the cover again.

Rinse aid indicator on the dispenser

dark - OK clear: needs to be added



! Only use rinse aids recommended for use in domestic dishwashers. Immediately wipe away any rinse aid spilt accidentally. This prevents the formation of excess suds which can cause a fault function of the appliance.

i If there are streaks: reduce the dosage by turning the dial to a lower setting (1-3). If crockery is not perfectly dry: increase the dosage by turning the dial to a higher setting (5-6). Plastic dishes have more difficulty drying and a higher rinse aid setting will not improve the situation.

i Detergents with rinse aid incorporated may be effective only with longer programs. In the case of shorter programs, detergent residue may be a problem (if necessary, use powder detergent). Detergents with rinse aid incorporated tend to form excess suds.

Daily use

Adding detergent - Use only detergent specifically for dishwashers in accordance with the supplier's recommendations.

Open the cover B (press the dedicated button).

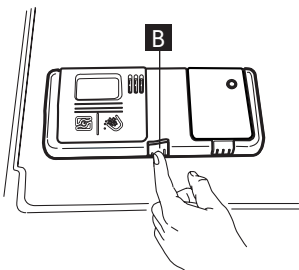

Insert detergent: Tablet / powder / liquid into the big chamber.

Only fill the detergent dispenser prior to starting a wash programme.

Use only one tablet per one cycle, only placed in detergent dispenser.

Shut the cover by pressing dedicated ribs.

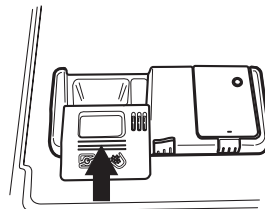

How to load the racks

Upper rack - depending on the model

Adjustable flaps (A): In horizontal position for cups/long utensils.

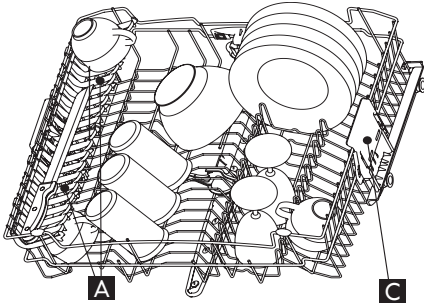

Cutlery basket (B): slide halves apart to split the basket.

Grid (E): helps to keep the cutlery separate for better washing results.

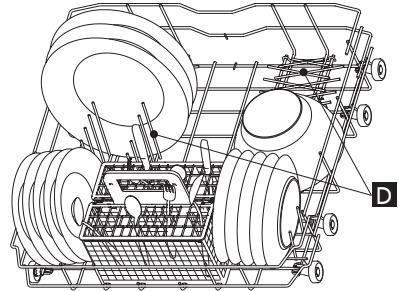

Cutlery basket - half (B): can be placed in the upper rack when the "Half load/ Multizone" is selected.

The Grid (E) should be removed.

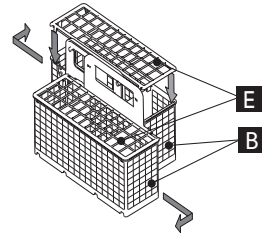
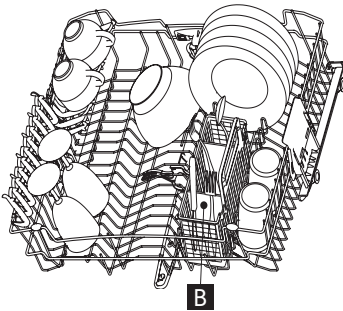

How to adjust upper rack height

(if available). It could be useful to lift up the upper rack to have more space in lower rack or bring it down to load long stem glasses.

- Grasp and take out the two lateral handles (C) - (they must be on the same level) and lift up or take down the upper rack.

Lower rack - depending on the model

Foldable plate holders (D): they can be folded down to load pots or Fixed plate holders.

! Arrange crockery so that water does not collect in cavities, ensuring that the spray arms turn freely. Only use dishwasher-proof crockery and dishes. Do not use the dishwasher for washing wooden items, aluminium, tin, silver cutlery or decorated crockery (unglazed). In the baskets, dishes (e.g. plates, bowls, pots) must be placed in a correct way to let water flow down!

Switching on the appliance. Press any button (except CANCEL/Off button) to switch on the control panel and start programming.

**Select programme
Overview of programs**

The corresponding programs for your appliance can be found on the panel.

- i** Choose program according to washing programmes.
Duration of the program depends on the external conditions in the apartment, temperature and pressure etc.

Wash cycle

The dishwasher door must be closed and the water tap open.

To pause the program (e.g. if you want to insert an item):

- Open the door with caution (the program pauses) and insert the item/s, (beware of HOT steam!).
- Close the door and press the START button again to restart the cycle (the program resumes the cycle from where it was interrupted).

To Cancel the program on running:

- Open the door, press the CANCEL/Off.
- (Water drains for up to 1 minute then the appliance switches off).

To change the program in progress:

- Press the CANCEL/Off button to cancel the program on running.
- (Water drains for up to 1 minute then the appliance switches off).
- Press any button except CANCEL/Off button to switch on the appliance.
- Select a new program.
- Press the START button.

Switch off the appliance Everything o.k ...

After the program is completed appliance turns into Standby mode automatically. All indicator lamps switch off.

Exercise caution when opening the door: beware of hot steam.

Unload the appliance starting from the lower rack in order to avoid any residual drips of water falling onto crockery below.

- i** For even better drying results, leave the dishwasher door open a little before unloading in order to allow the steam to dissipate, helping the dishes to dry. The underside of the kitchen worktop must be protected (see instructions in 'Assembly instructions').

Cleaning and maintenance

Spray arms

Remove blockages/deposits.
Unscrew and remove upper arm (A-B).

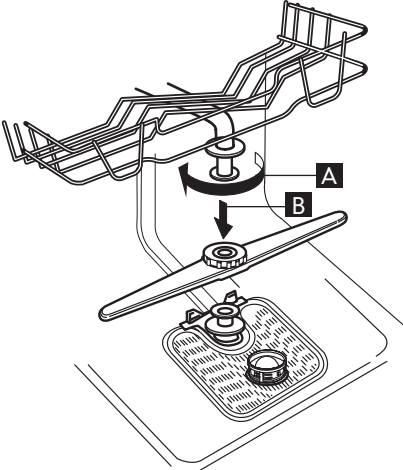

Unscrew and remove lower arm (C-D).

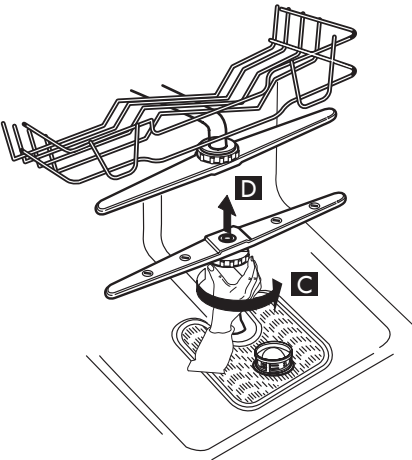

Clean spray nozzles under running water (use toothpicks if necessary).
Insert and screw on upper and lower arms tightly.

Filters

Check and clean if necessary.
Unscrew microfilter, remove it (E) and remove fine sieve (F).

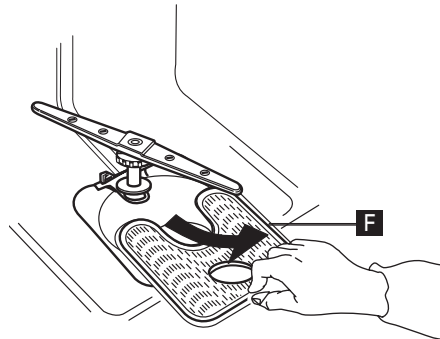
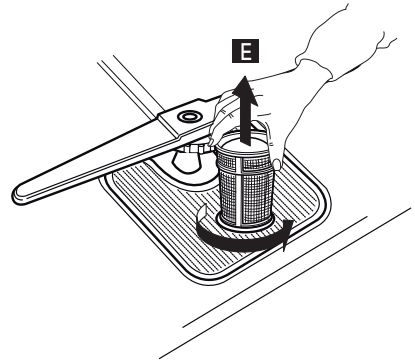

Rinse under running water and insert again.



What to do if ...



If a fault occurs, before contacting the After-sales Service, make the following checks to try and remedy the problem. Most faults can be remedied by taking the following courses of action, quickly restoring normal appliance operation.

The appliance...	Possible causes...	Solutions...
<p>...is not working/will not start</p>	<ul style="list-style-type: none"> - The appliance must be switched on. 	<ul style="list-style-type: none"> - Check the household circuit fuse if there is no power supply.
	<ul style="list-style-type: none"> - The dishwasher door doesn't close 	<ul style="list-style-type: none"> - Check if the dishwasher's door is closed.
	<ul style="list-style-type: none"> - Delayed start option is ON. 	<ul style="list-style-type: none"> - Check whether the "Delayed Start" option (if available) has been selected. If it has, the appliance will only start once the set time has elapsed. If necessary, set the delayed start to "0" (RESET the appliance).
<p>...the CANCEL/Off indicator lamp blinks 6 times</p>	<ul style="list-style-type: none"> - Water tap closed. 	<ul style="list-style-type: none"> - The water tap must be open.
	<ul style="list-style-type: none"> - Kinked water inlet hose or clogged inlet filters. 	<ul style="list-style-type: none"> - The water inlet hose must not be kinked and the relative inlet filter in the water tap connector must not be dirty or clogged.
	<ul style="list-style-type: none"> - Water pressure too low. 	<ul style="list-style-type: none"> - The water tap must be fully open during water inlet (minimum capacity: 0,5 liters per minute).
<p>...the CANCEL/Off indicator lamp blinks 6 times/wash program ended too early (dishes are dirty and wet)</p>	<ul style="list-style-type: none"> - Dirty or clogged filters. 	<ul style="list-style-type: none"> - The filters must not be dirty or clogged.
	<ul style="list-style-type: none"> - Too little water in the dishwasher's water system. 	<ul style="list-style-type: none"> - Concave items (e.g. Bowls, cups) must be arranged facing downwards in the rack.
	<ul style="list-style-type: none"> - Drain hose incorrectly fitted. 	<ul style="list-style-type: none"> - The drain hose must be fitted correctly (for high mounted appliances, leave min. 200-400 mm from the lower edge of the appliance) - see Assembly Instruction.
	<ul style="list-style-type: none"> - High level of foam inside. 	<ul style="list-style-type: none"> - Repeat without detergent or wait until foam disappears.
<p>...the CANCEL/Off indicator lamp blinks 8 times</p>	<ul style="list-style-type: none"> - Dirty filters. 	<ul style="list-style-type: none"> - Clean the filters.
	<ul style="list-style-type: none"> - Kinked drain hose 	<ul style="list-style-type: none"> - The drain hose must not be kinked.
	<ul style="list-style-type: none"> - Syphon hose connection closed. 	<ul style="list-style-type: none"> - The closure disk of the syphon hose connection must be removed.

After taking the above course of action, the fault message must be reset. In the majority of cases the fault is thus eliminated.

RESET: → Press the CANCEL/Off button.

→ Close the door.

→ Water drains automatically for up to 1 minute.

→ The appliance is now ready to be restarted.

Crockery and cutlery...	Possible causes...	Solutions...
<p>...are not perfectly clean/ have food residues</p>	<ul style="list-style-type: none"> - Too little space between dishes (Incorrect arrangement of the concave items in the rack). 	<ul style="list-style-type: none"> - Arrange crockery so that items do not touch each other. Concave items (e.g. bowls, cups) must be arranged facing downwards in the rack.
	<ul style="list-style-type: none"> - Too little detergent; detergent too old or incorrectly stored. 	<ul style="list-style-type: none"> - If necessary, use more detergent, observing the manufacturer's indications as regards dosage. Always store detergent in a dry place and do not store it for excessively long periods of time.
	<ul style="list-style-type: none"> - Temperature not high enough for heavily soiled crockery. 	<ul style="list-style-type: none"> - For heavily soiled crockery, select a wash program with a higher temperature (see "washing programmes").
	<ul style="list-style-type: none"> - Loading of the dishwasher using lower and upper rack in the same time with "Half load / Multizone" option 	<ul style="list-style-type: none"> - If you select the "Half load / Multizone" option (if available), remember to load only the upper rack or only the lower rack to increase washing power and thus obtain optimum wash results.
	<ul style="list-style-type: none"> - Frequent use of Eco 40°C. 	<ul style="list-style-type: none"> - In the event of frequent use of the Eco programme 40°C (if available), from time to time select the intensive o 70°C program (if available).
	<ul style="list-style-type: none"> - Clogged spray arms, dirty filters or not fitted correctly. 	<ul style="list-style-type: none"> - The spray arms must not be clogged, the filters must not be dirty and must be fitted correctly (see "Cleaning and Maintenance").
	<ul style="list-style-type: none"> - Spray arms stuck impeded by crockery or cutlery. 	<ul style="list-style-type: none"> - The spray arms must be able to turn freely and must not be impeded by crockery or cutlery.

Crockery and cutlery...	Possible causes...	Solutions...
...are not dry	- Plastic containers dry badly.	- Synthetic materials do not dry well; if wet at end of cycle, wipe dry.
	- Clean dishes left in dishwasher for a long time after end of cycle (e.g. when using "Delayed start" option).	- In this situation, the presence of drops of water on dishes and on the sides of the dishwasher is normal. Try releasing the door 5 minutes before removing the dishes.
	- Incorrect arrangement of the concave items in the rack.	- Arrange crockery so that water does not collect in cavities.
	- Incorrect dosage the rinse aid.	- Increase the dosage of rinse aid (see "Adding rinse aid").
	- Rapid program selected.	- The rapid program 40°C / 45°C is intended for quickly washing lightly soiled dishes. If used for a full load of medium/heavy soiled dishes, the dishes may not dry completely. If so, select a standard-length programme. For best results, open the door after the end of the program and wait 15 minutes before unloading the dishwasher.
...have discoloured plastic parts	- Tomato/Carrot juice.	- Tomato sauce, for example, can lead to discolouring of plastic parts. Powder detergent is recommended as it allows slightly higher doses to be used for improved whitening. Programs with higher wash temperatures should be used.
...opaque glasses, etc.	- Dishes unsuitable for washing in dishwashers (porcelain).	- Only use dishwasher-proof crockery and dishes.
...removable deposits on glasses	- Usage of incorrect programmes for glasses.	- Dishes should be put together, to avoid touching each other. Do not put glassware together in baskets. Use suitable programme for glass.
...glasses not sparkling	- Not conform of glasses to washing in dishwashers (porcelain).	- Some kinds of glass cannot be washed in the dishwasher.

Crockery and cutlery...	Possible causes...	Solutions...
...permanent deposits on glasses	- Rainbow effect.	- This phenomenon is irreversible. We recommend in future: <ul style="list-style-type: none"> • Be careful – follow recommended detergent dosage, • For combined action tablets see detergent producer’s recommendations.
...tea cups darken and dirt does not disappear after washing in dishwasher	- Not known.	- This phenomenon is inevitable. Theine alters colours permanently.
...rust marks	- Pre-wash programme not used.	- Salty or acidic food residues can cause rust marks even on stainless steel cutlery. To avoid this, always use the pre-wash programme if the dishes are to be washed later.
...other marks	- Rinse aid dosage too low.	- In the presence of marks, increase the rinse aid dosage (see “Adding rinse aid”). - If you use a combined action detergent, possibly add more rinse aid.
...streaks	- Rinse aid dosage too high.	- In the presence of streaks, reduce the rinse aid dosage (see “Adding rinse aid”). - If you use a combined action detergent try adding more rinse aid.
...suds	- Unsuitable dosage of detergent/rinse aid.	- Only use the amount of detergent / rinse aid required, since excessive amounts can lead to excess suds.

If, after carrying out the above checks, the fault persists, disconnect the mains plug and turn off the water tap. Contact the After-sales Service (see warranty).

Before contacting our After-Sales Service, take note of the following:

- the description of the fault,
- the appliance type and model,

- the service code (the number indicated on the adhesive rating plate) inside the door on the right-hand side:

SERVICE 0000 000 00000



Environmental concerns

1. Packing

The packaging materials are 100% recyclable and marked with the recycling symbol.

2. Disposal

The appliance is manufactured using recyclable materials. If you decide to scrap the dishwasher, it must be disposed of in compliance with local waste disposal regulations. Make it unusable by cutting off the power cord. To prevent situations of potential danger to children (e.g. danger of suffocation), break the lock of the door so that it can no longer be closed.

This appliance is marked according to the European directive 2002/96/CE on Waste Electrical and Electronic Equipment (WEEE). By ensuring that this appliance is scrapped suitably, you can help prevent potentially damaging consequences for the environment and health. Unsuitable disposal of an appliance of this type as household waste could have detrimental effects on



the environment. The symbol  on the appliance, or on documentation enclosed with the appliance, indicates that this product must not be treated as household waste, but must be delivered to the nearest collection centre for the recycling of electrical and electronic appliances. Disposal must be carried out in accordance with local environmental regulations for waste disposal. For further information on the treatment, recovery and recycling of this appliance, contact your competent local authority, the collection service for household waste or the shop where you purchased the appliance.

EC Declaration of conformity

- This appliance has been designed, constructed and distributed in compliance with the safety requirements of EC Directives:



2006/95/CE, 89/336/CE, 93/68/CE and 2002/95/CE (RoHS Directive).

We reserve the right to make technical modifications.

The guarantee is not applicable if faults are caused by incorrect use of the appliance.

IKEA GUARANTEE

How long is the IKEA guarantee valid?

This guarantee is valid for five (5) years from the original date of purchase of your appliance at IKEA, unless the appliance is named LAGAN in which case two (2) years of guarantee apply. The original sales receipt, is required as proof of purchase. If service work is carried out under guarantee, this will not extend the guarantee period for the appliance.

Which appliances are not covered by the IKEA five (5) years guarantee?

The range of appliances named LAGAN .

Who will execute the service?

IKEA has appointed Whirlpool (Australia) Pty Ltd as the authorised service network partner.

- If you encounter any trouble with the appliance and wish to register a call with Whirlpool, please call:

**Australia contact centre:
1300 363 344.**

What does this guarantee cover?

The guarantee covers applicable faults of the appliance, as per the terms and conditions, from the date of purchase from IKEA. This guarantee applies to domestic use only. The exceptions are specified under the headline "What is not covered under this guarantee?" Within the guarantee period, the costs to remedy the fault e.g. repairs, parts, labour and travel will be covered, provided that the appliance is accessible for repair without special expenditure. Replaced parts become the property of IKEA.

The services will be in-home service for domestic appliances, and must to be done by official Whirlpool service network. Goods presented for repair may be replaced by refurbished goods of the same type rather than being repaired.

Refurbished parts may be used to repair the goods.

If the authorized service agent requests you to deliver the product directly to them, please ensure that the appliance is suitably packaged to prevent any damage during transportation.

What will IKEA do to correct the problem?

IKEA appointed service provider will examine the product and decide, at its sole discretion, if it is covered under this guarantee. If considered covered, IKEA service provider or its authorized service partner through its own service operations, will then, at its sole discretion, either repair the defective product or replace it with the same or a comparable product.

What is not covered under this guarantee?

- Normal wear and tear.
- Deliberate or negligent damage, damage caused by failure to observe operating and maintenance instructions, incorrect installation or by connection to the wrong voltage, damage caused by chemical or electrochemical reaction, rust, abrasion or scratching, corrosion or water damage including but not limited to damage caused by excessive lime in the water supply, damage caused by abnormal environmental conditions.
- Damage caused from the use of the appliance in a manner other than the use for which it was specifically designed.
- Damage caused by power outages, electrical power surge or improper supply voltage via connection to Supply Authority mains or alternative supply systems.
- Consumable parts including batteries and lamps, removable wire, glass and plastic trays and other accessories.

- Internal or external damage as a result of excessive use of cleaning products or cleaning agents.
 - Non-functional and decorative parts which do not affect normal use of the appliance, including any scratches and possible color differences.
 - Accidental damage or blockages caused by foreign objects, eg. coins, underwires, nails, buttons or jewellery, or substances and cleaning or unblocking of filters, drainage systems or soap drawers
 - Damage caused by vermin, insects or pets.
 - Note – internal or external cabinet transport damage must be reported within 7 days of purchase date.
 - Damage to the following parts: ceramic glass, accessories, crockery and cutlery baskets, feed and drainage pipes, seals, lamps and lamp covers, screens, knobs, casings and parts of casings. Unless such damages can be proved to have been caused by production faults.
 - Cases where no fault could be found during a technician's visit.
 - Any consequential loss due to appliance failure.
 - Repairs not carried out by our appointed service providers and/or an authorized service contractual partner or where non original parts have been used.
 - Repairs to parts or systems caused by unauthorized modifications made to appliance.
 - Repairs caused by installation which is faulty or not according to specification.
 - Problems caused by incorrect or inadequate venting of the appliance.
 - The use of the appliance in a non domestic environment i.e. professional use.
 - Transportation damages. If a customer transports the product to his home or another address, IKEA is not liable for any damage that may occur during transport. However, if IKEA delivers the product to the customer's delivery address, then damage to the product that occurs during this delivery will be covered by IKEA.
 - Cost for carrying out the initial installation of the IKEA appliance. However, if an IKEA appointed service provider or its authorized service partner repairs or replaces the appliance under the terms of this guarantee, the appointed service provider or its authorized service partner will reinstall the repaired appliance or install the replacement, if necessary.
 - The benefits conferred by this express warranty are in addition to all other conditions, warranties, guarantees, rights and remedies expressed or implied by the Trade Practices Act and similar State and Territory laws and all other obligations and liabilities on the part of the manufacturer or supplier and nothing contained herein shall restrict or modify such rights, remedies, obligations or liabilities.
- How country law applies?**
- Our goods come with guarantees that cannot be excluded under the Australian Consumer Law. You are entitled to a replacement or refund for a major failure and for compensation for any other reasonably foreseeable loss or damage. You are also entitled to have the goods repaired or replaced if the goods fail to be of acceptable quality and the failure does not amount to a major failure.
- Area of validity**
- The IKEA guarantee applies only to products purchased and installed in AUSTRALIA .

The dedicated AFTER SALES for IKEA appliances

Please don't hesitate to contact IKEA appointed After Sales Service Provider to:

- make a service request under this guarantee;
- ask for clarifications on installation of the IKEA appliance in the dedicated IKEA kitchen furniture;
- ask for clarification on functions of IKEA appliances.
- Call our authorized service network partner Whirlpool on **1300 363 344 (Australia)**.

WARRANTY PROCEDURE

Please ensure that installation procedure entailed in the user manual has been adhered to and in case of any doubts please refer to the trouble shooting guide that has been supplied with the appliance.

- Please read the user guide to ensure that you are aware of all the features & benefits of the appliance.

How to reach if you need our service

The Whirlpool call centre team will assist you on the phone with basic trouble shooting for your appliance at the time of warranty call registration.



1300 363 344

Please describe the problem that you are facing with the appliance in detail along with your product model number, serial number, date of purchase at the time of call registration.

Please also always refer to the IKEA article number (8 digit code) and 12 digit service number placed on the rating plate of your appliance.



SAVE THE SALES RECEIPT!

Kindly keep all these details and original invoice of purchase handy during the service technician's visit to enable him to carry out the job.



Whirlpool reserves the right not to register the call under warranty if you fail to provide these details at the time of call registration.

Do you need extra help?

For any additional questions not related to After Sales of your appliances please contact your nearest IKEA store call centre. We recommend you read the appliance documentation carefully before contacting us.

For details on service agents locations, please visit – www.whirlpool.com.au/services.

